

ergotron®

HX Desk Dual Monitor Arm

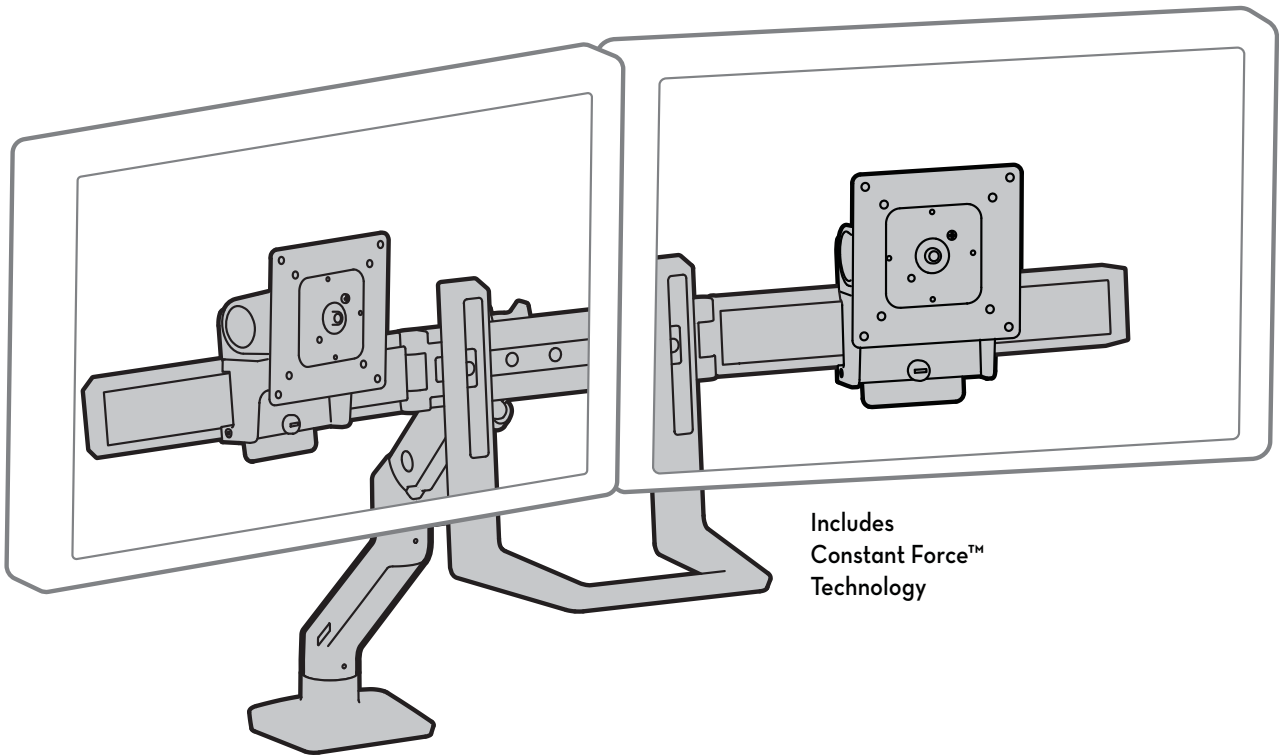

Includes
Constant Force™
Technology

EN User Guide

ES Guía del usuario

FR Manuel de l'utilisateur

DE Gebruikersgids

JA ユーザーガイド



www.ergotron.com: English, Español, Français, Deutsch, Nederlands, Italiano, Türkçe, 日本語, 汉语

www.ergotron.com | USA: 1-800-888-8458 | Europe: +31 (0)33-45 45 600 | China: 400-120-3051 | Japan: japansupport@ergotron.com

Hazard Symbols Review

These symbols alert users of a safety condition that demands attention. All users should be able to recognize and understand the significance of the following Safety Hazards if encountered on the product or within the documentation. Children who are not able to recognize and respond appropriately to Safety Alerts should not use this product without adult supervision!

Revisión de los símbolos de peligro

Estos símbolos alertan a los usuarios sobre un tema de seguridad que requiere su atención. Todos los usuarios deben poder reconocer y comprender el significado de los siguientes riesgos de seguridad si los ve en el producto o en la documentación. Los niños que no puedan reconocer y responder de forma adecuada a las alertas de seguridad no deben utilizar este producto sin la supervisión de un adulto.

Examen des symboles de danger





Ces symboles avertissent les utilisateurs de conditions de sécurité nécessitant leur attention. Les utilisateurs doivent être en mesure de reconnaître et de comprendre ce que signifient les risques pour la sécurité suivants s'ils les voient sur le produit ou dans la documentation du produit. Les enfants qui ne peuvent pas reconnaître ni répondre correctement aux avertissements de sécurité ne doivent pas utiliser le produit sans la supervision d'un adulte !

Überblick über die Gefahrensymbole

Diese Symbole machen den Benutzer auf einen sicherheitsgefährdenden Zustand aufmerksam, der behoben werden muss. Alle Benutzer sollten die folgenden Gefahrensymbole am Produkt bzw. in der Dokumentation erkennen und ihre Bedeutung verstehen können. Kinder, die Sicherheitswarnungen nicht verstehen und angemessen darauf reagieren können, dürfen dieses Produkt nur unter Aufsicht durch Erwachsene benutzen!

危険記号の説明

これらの記号は、ユーザーが注意すべき安全面の条件について警告するものです。製品またはドキュメントで次のような安全上の問題に直面した際、その重大さを認識して理解できる必要があります。安全上の注意を認識し、適切に対応できない子供が本製品を使用する場合は、大人の監督が必要です。

Symbol Símbolo Symbole Symbol 記号	Signal Word Símbolo Mot signal Signalwort 記号が表す言葉	Level of Hazard Nivel de riesgo Niveau de danger Gefahrenstufe 危険レベル
	NOTE NOTA REMARQUE HINWEIS 注	A NOTE indicates important information that helps you make better use of this product. Una NOTA presenta información importante que le ayudará a utilizar mejor este producto. Une REMARQUE indique des informations importantes destinées à vous aider à mieux utiliser de ce produit. Ein HINWEIS verweist auf wichtige Informationen, mit deren Hilfe Sie dieses Produkt besser nutzen können. 注は、本製品をより良く使用するための重要な情報です。
	CAUTION PRECAUCIÓN ATTENTION VORSICHT 注意	A CAUTION indicates either potential damage to hardware or loss of data and tells you how to avoid the problem. La PRECAUCIÓN indica la probabilidad de dañar el hardware o de perder datos y le señala la forma de evitar el problema. La mention ATTENTION indique la possibilité de dommages matériels ou de perte de données ainsi que la manière d'éviter le problème. Der Hinweis VORSICHT verweist auf potenzielle Hardwareschäden oder Datenverluste und informiert Sie darüber, wie Sie das Problem vermeiden können. 注意は、ハードウェアの損傷やデータ損失の可能性を示しており、問題を回避する方法も説明されています。
	WARNING ADVERTENCIA AVERTISSEMENT ACHTUNG 警告	A WARNING indicates either potential for property damage, personal injury, or death. Una ADVERTENCIA indica la probabilidad de daños materiales, lesiones personales o muerte. Un AVERTISSEMENT indique la possibilité de blessures personnelles potentiellement mortelles et de dommages matériels. Der Hinweis ACHTUNG verweist auf potenzielle Sachschäden oder Verletzungen bis hin zum Tod. 警告は、機器の損傷や人体の怪我を引き起こしたり、死に至らしめる可能性がある事態であることを示しています。
	ELECTRICAL ELÉCTRICO ÉLECTRIQUE ELEKTRIK 電気	An Electrical indicates an impending electrical hazard which, if not avoided, may result in personal injury, fire and/or death. Eléctrico indica un peligro eléctrico inminente que, si no se evita, puede dar lugar a lesiones personales, incendios y/o la muerte. Un symbole électrique signale une situation électrique potentiellement dangereuse qui, si elle n'est pas évitée, risque d'entraîner des blessures potentiellement mortelles et des incendies. Der Hinweis ELEKTRIK verweist auf eine drohende elektrische Gefahr die, wenn sie nicht vermieden wird, Verletzungen, einen Brand und/oder den Tod zur Folge haben kann. 電気は、回避しないと怪我、火災、死亡の恐れがある切迫した電気に関連する危険を示します。



Important! You will need to adjust this product after installation is complete. Make sure all your equipment is properly installed on the product before attempting adjustments. This product should move smoothly and easily through the full range of motion and stay where you set it. If movements are too easy or difficult or if product does not stay in desired positions, follow the adjustment instructions to create smooth and easy movements. Depending on your product and the adjustment, it may take many turns to notice a difference. Any time equipment is added or removed from this product, resulting in a change in the weight of the mounted load, you should repeat these adjustment steps to ensure safe and optimum operation.

¡Importante! Tendrá que ajustar este producto una vez que haya terminado la instalación. Asegúrese de que todo su equipo esté instalado correctamente en el producto antes de intentar llevar a cabo algún ajuste. Este producto debe poder moverse de manera fácil y firme dentro de la amplitud de movimiento permitida y mantenerse donde usted lo fije. Si los movimientos son demasiado fáciles o difíciles o si el producto no se mantiene en las posiciones deseadas, siga las instrucciones de ajuste para conseguir movimientos suaves y fáciles. Dependiendo del producto y el ajuste, es posible que deba hacer muchos intentos hasta poder observar la diferencia. Cada vez que añada o retire equipos de este producto y que produzca un cambio en el peso de la carga, debe repetir estos pasos de ajuste para garantizar un funcionamiento seguro y óptimo.

Important! Vous devez ajuster le produit une fois l'installation terminée. Assurez-vous que l'équipement est correctement installé sur le produit avant de procéder aux ajustements. Ce produit doit pouvoir être déplacé sans difficulté sur toute la plage de mouvement et rester immobilisé à l'endroit où il est réglé. Si le mouvement est trop facile ou trop difficile, ou si le produit ne reste pas dans les positions souhaitées, procédez selon les instructions de réglage pour harmoniser les mouvements. En fonction de votre produit et du réglage, plusieurs tours peuvent s'avérer nécessaire pour remarquer la différence. Chaque fois qu'une pièce d'équipement est ajoutée ou retirée de ce produit, affectant en conséquence le poids de la charge montée, vous devez répéter ces étapes de réglage afin de garantir une utilisation sécurisée et optimale du produit.

Wichtig! Sie müssen dieses Produkt nach dem Zusammenbau entsprechend einstellen. Achten Sie darauf, dass alle Ihre Geräte richtig auf dem Produkt installiert wurden, bevor Sie irgendwelche Einstellungen vorzunehmen versuchen. Dieses Produkt sollte sich in seinem gesamten Bewegungsbereich ruckfrei und ohne Schwierigkeiten bewegen lassen und an der Stelle bleiben, an der es abgestellt wird. Wenn die Bewegungen zu leicht oder nur mit großer Anstrengung durchgeführt werden können oder das Produkt nicht in der vorgesehenen Position bleibt, beachten Sie die Einstellanleitung, um ruckfreie und einfache Bewegungen zu ermöglichen. Je nach Ihrem Produkt und der jeweiligen Einstellung können zahlreiche Manipulationen erforderlich sein, bevor Sie einen Unterschied feststellen. Zur Sicherstellung einer sicheren und optimalen Produktfunktion sollten Sie diese Einstellschritte immer dann durchführen, wenn Geräte hinzugefügt oder entfernt werden, was eine Veränderung der Traglast zur Folge hat.

重要! 本製品は取り付け後に調整する必要があります。調整を行う前に、すべての機器が本製品に適切に取り付けられていることを確認してください。本製品は可動範囲内でスムーズかつ簡単に動く必要があり、選定した位置にしっかり固定されなければなりません。製品が簡単に動きすぎる場合、動きがぎこちない場合、あるいは目的の位置に固定されない場合は、説明書に従いスムーズに動くように調整してください。お使いの製品や調整によっては、違いがはっきりするまで何回か回さなければならないこともあります。本製品に機器を追加したり、機器を取り外したことで積載重量が変わった場合は、安全かつ最適な操作を実現するために調節手順を繰り返してください。



Warning: Because mounting surface materials can vary widely, it is imperative that you make sure mounting surface is strong enough to handle mounted product and equipment.

Advertencia: Dado que los materiales de la superficie de montaje pueden variar enormemente, es imprescindible que se cerciore de que la superficie sea lo suficientemente resistente como para sostener el equipo y el producto montados.

Avertissement : Dans la mesure où les matériaux des surfaces de montage varient, vous devez impérativement vous assurer que la surface est suffisamment solide pour supporter le produit et l'équipement monté.

Warnung: Weil die Materialien der Befestigungsflächen stark variieren können, müssen Sie unbedingt gewährleisten, dass die Befestigungsfläche stark genug ist, um das montierte Produkt und die Ausrüstung zu tragen.

警告: 取り付け表面の材質にはさまざまな種類があるため、取り付け表面が取り付け製品や器具に対応した強さであることを必ず確認してください。



Caution:

To avoid the potential to pinch cables it is important to follow the cable routing instructions in this manual. Failure to follow these instructions may result in equipment damage or personal injury.

Precaución:

Para evitar la posibilidad de que se doblen los cables, es importante seguir las instrucciones de organización de los cables de este manual. En caso de no respetar estas instrucciones, podrían producirse daños en el equipo o lesiones físicas.

Attention :

Pour éviter de risquer de pincer les câbles, il est important de suivre les instructions d'acheminement des câbles de ce manuel. Le non-respect de cette consigne peut entraîner des dommages matériels et/ou des blessures.

Vorsicht:

Damit keine Kabel eingeklemmt werden können, müssen Sie die Anweisungen zur Kabelführung in diesem Handbuch einhalten. Ein Missachten dieser Anweisungen kann zu Geräteschäden oder Verletzungen führen.

注意:

ケーブルの挟まりを防ぐため、必ず本マニュアルのケーブル配線手順に従ってください。この指示に従わないと、機器の損傷や怪我を招く恐れがあります。



WARNING! Stored Energy Hazard: The arm mechanism is under tension and will move up rapidly, on its own, as soon as attached equipment is removed. For this reason, **DO NOT** remove equipment unless the arm has been moved to the highest position! Failure to follow this instruction may result in serious personal injury and/or equipment damage!

ADVERTENCIA: Riesgo de energía almacenada: El mecanismo del brazo está bajo tensión y se moverá rápidamente hacia arriba, por sí mismo, tan pronto como se retire el equipo acoplado. Por ello, **NO** retire el equipo a menos que esté colocado en su posición más elevada. El incumplimiento de esta instrucción puede provocar lesiones personales graves y dañar el equipo.

AVERTISSEMENT! Risque d'énergie accumulée : Le mécanisme du bras est sous tension et se lèvera rapidement, tout seul, dès que le matériel est retiré. Pour cette raison, **NE PAS** retirer votre matériel à moins que le bras n'ait été mis à la position la plus élevée ! Risque de blessure corporelle et/ou d'endommagement du matériel en cas de non-respect de cette instruction !

WAARSCHUWING! Rischio da energia immagazzinata: il meccanismo del braccio è sotto tensione e si muove rapidamente da sé non appena si toglie l'apparecchiatura a cui è collegato. Per questo motivo, **NON** rimuovere l'apparecchio a meno che il braccio non sia stata portato sulla posizione più alta. La mancata osservanza di questa precauzione può causare infortuni gravi e/o danni all'apparecchiatura.

警告: 蓄積エネルギーの危険: アームメカニズムには張力が作用しており、付属機器を取り外すと自動的に素早く上に跳ね上がります。そのため、付属機器を取り外す前にアームは一番上の位置に移動してください。この指示を無視すると、重大な人体への傷害や機器の損傷を招く恐れがあります。

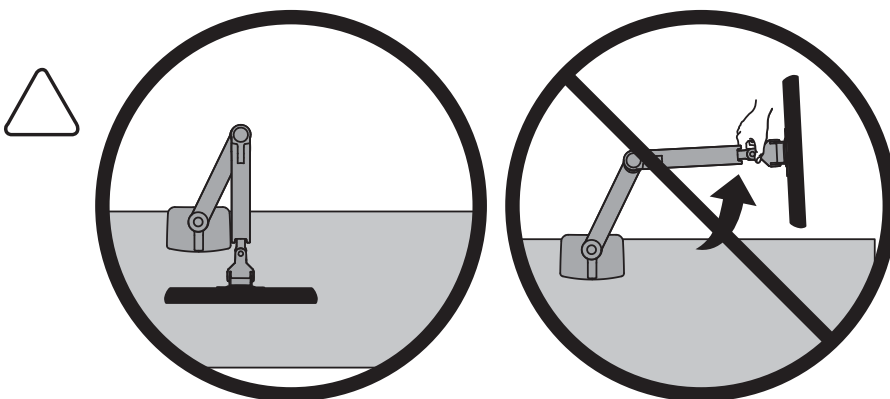

CAUTION: DO NOT rotate monitor past rear edge of desk. Doing so will create an unstable situation and may cause equipment damage or personal injury.

PRECAUCIÓN: **NO** gire el monitor más allá del borde trasero del escritorio. Si lo hace, se creará una situación de inestabilidad que puede ocasionar daños al equipo o lesiones personales.

ATTENTION : **NE** faites **PAS** tourner l'écran au-delà du bord arrière du bureau. Cela crée une situation instable et peut endommager les équipements ou entraîner des blessures.

VORSICHT: Den Monitor **NICHT** über die Hinterkante des Tisches hinaus drehen. Dies würde zu einer instabilen Anordnung und eventuell zu Geräteschäden und Verletzungen führen.

注意: モニターがデスク後方の端から出ないようにしてください。モニターがデスク後方の端から出ると不安定になり、機器の損傷や人体への障害を招く恐れがあります。

Features & Specifications

Características y especificaciones técnicas

Features & Specifications

Produkteigenschaften & Technische Daten

特長と仕様

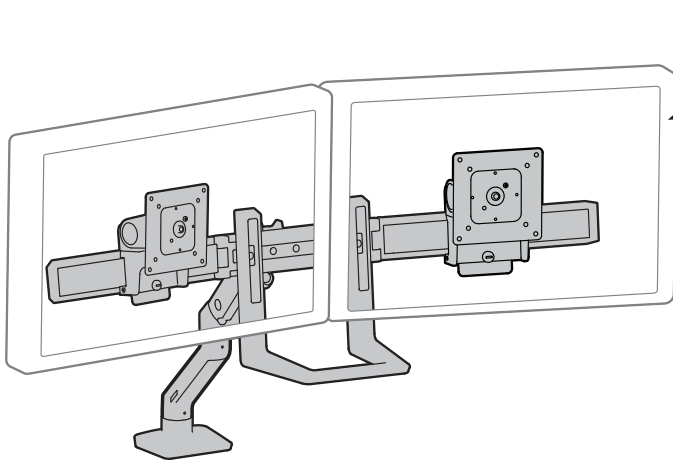

5 lbs. (2.3 kg) - 17.5 lbs. (7.9 kg)

CAUTION: DO NOT EXCEED MAXIMUM LISTED WEIGHT CAPACITY. SERIOUS INJURY OR PROPERTY DAMAGE MAY OCCUR!

PRECAUCIÓN: NO SUPERE LA CAPACIDAD DE PESO MÁXIMA INDICADA. PODRÍA OCURRIR DAÑOS MATERIALES GRAVES O LESIONES FÍSICAS.

ATTENTION : NE PAS DÉPASSER LA CAPACITÉ NOMINALE MAXIMALE MENTIONNÉE. DE SÉRIEUSES BLESSURES OU DES DOMMAGES MATÉRIELS POURRAIENT SE PRODUIRE !

VORSICHT: DIE ANGEGEBENE MAXIMALE TRAGFÄHIGKEIT NICHT ÜBERSCHREITEN. DIES KANN SCHWERE VERLETZUNGEN ODER SACHSCHÄDEN ZUR FOLGE HABEN!

注意:積載物は記載の最大積載重量を超えてはなりません。重大な人体の怪我や機器の損傷を招く恐れがあります。

Features & Specifications

Características y especificaciones técnicas

Features & Specifications

Produkteigenschaften & Technische Daten

特長と仕様

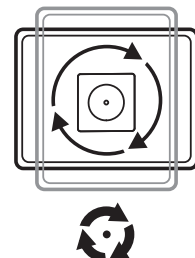
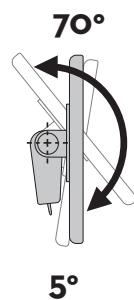
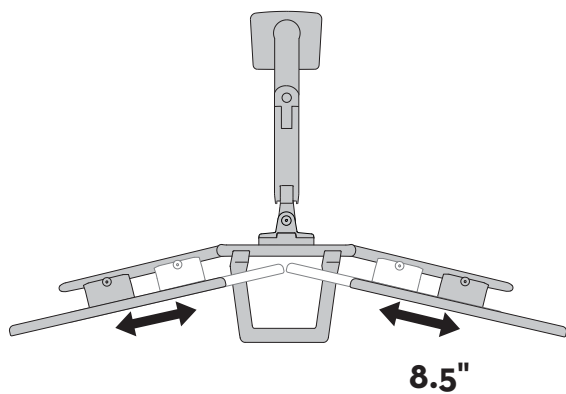
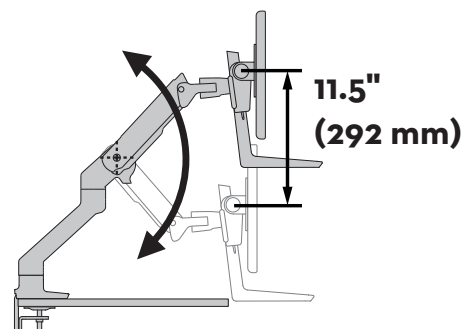
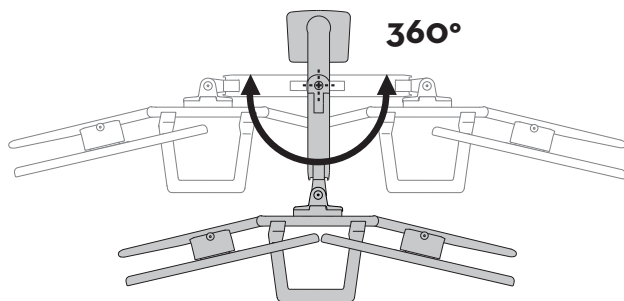
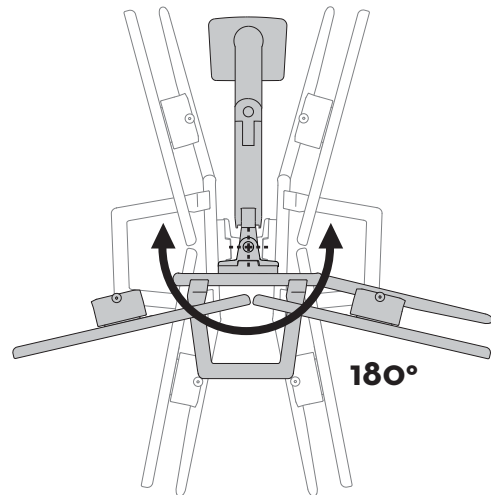
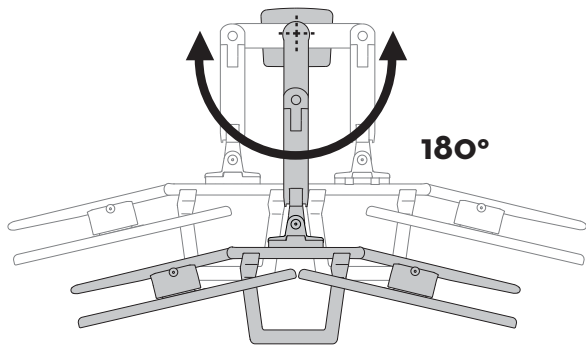
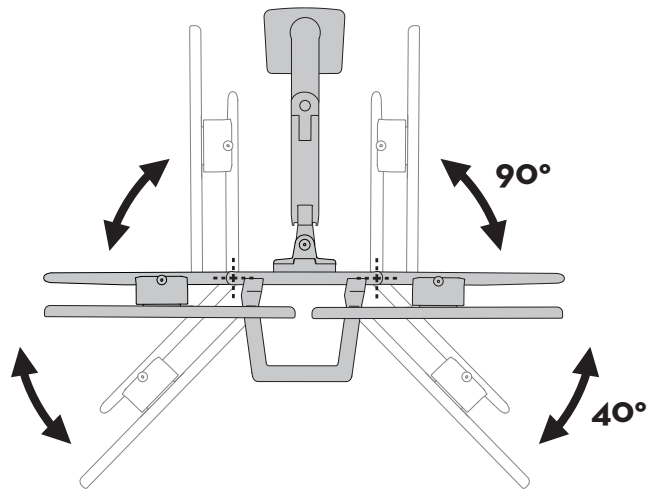
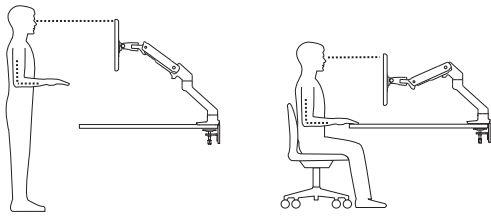



	A	B	C	D
1	1x 			2x M6 x 22mm
2	1x 	1x 	1x 	1x
3	2x M4 x 8mm 2x 	1x 	1x M10 x 95mm	2x
4	2x M4 x 22.5mm	1x M10	1x 	2x 11.5 x 6.5 x 1
5	2x 2x 	2x Security Screw M4 x 20mm	8x M4 x 10mm 8x M4 x 10mm	2x
6	1x 4mm	1x 2.5mm	1x 4mm 5 Sided Security Wrench	2x M6 x 14mm

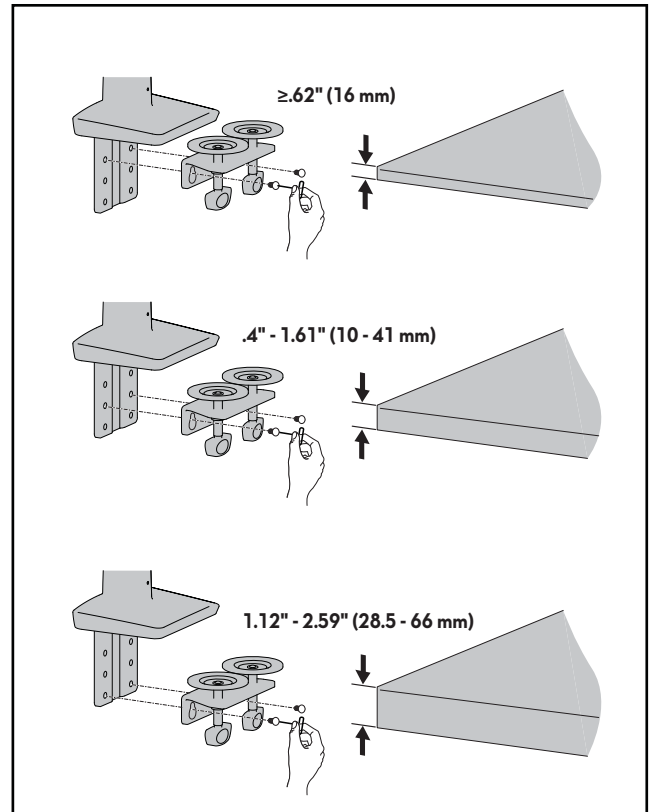
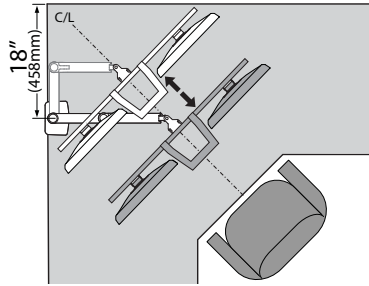
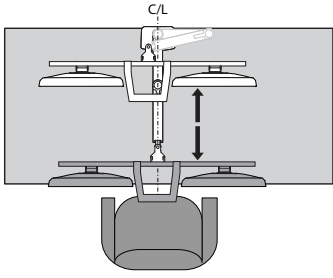
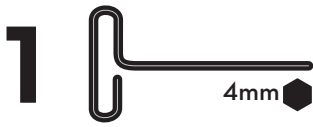

NOTE: Determine if arm will typically collapse to the left or right before installation.

NOTA: Determine si el brazo caerá normalmente hacia la izquierda o hacia la derecha antes de la instalación.

REMARQUE : Déterminez si le bras aura tendance à tomber vers la gauche ou vers la droite avant l'installation.

HINWEIS: Vor der Installation prüfen, ob der Arm normalerweise nach links oder rechts eingeklappt wird.

注意: インストール前に、アームが通常、左か右に傾くかどうかを確認します。

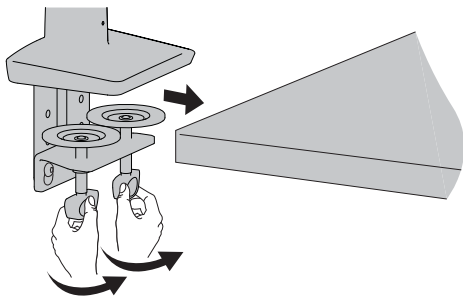

OPTIONAL: Grommet Mount Installation

Opcional: instalación con montura en ojal

Facultatif: Installation de l'œillet de montage pour trou passe-câbles

Optional: Grommet Mount-Montage

オプション: グロメットマウントの取り付け

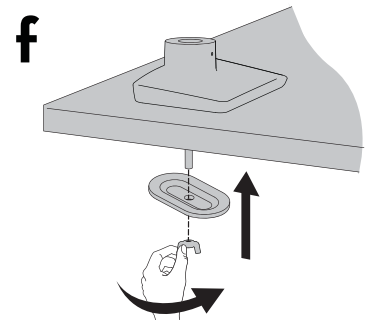
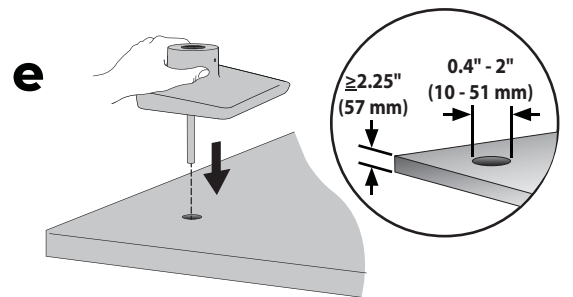
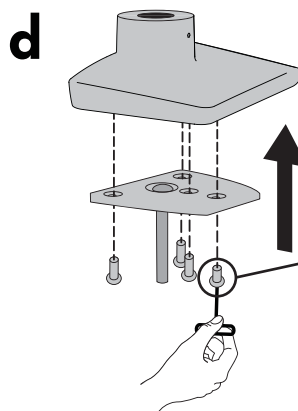
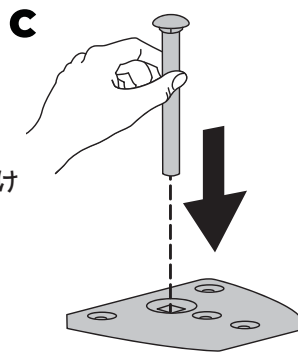
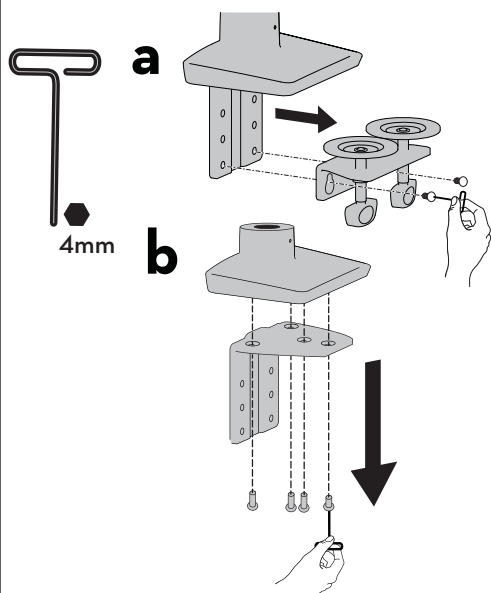

NOTE: The short screw must be reinstalled in the front hole of the grommet mount.

NOTA: El tornillo corto debe reinstalarse en el orificio frontal del montaje de ojal.

REMARQUE : La vis courte doit être réinstallée dans le trou avant de l'œillet de montage pour trou passe-câbles.

HINWEIS: Die kurze Schraube muss wieder in die vordere Bohrung der Tüllenhalterung eingesetzt werden.

注: 短いネジはグロメットマウントの前の穴に再インストールすること。

2  2.5mm

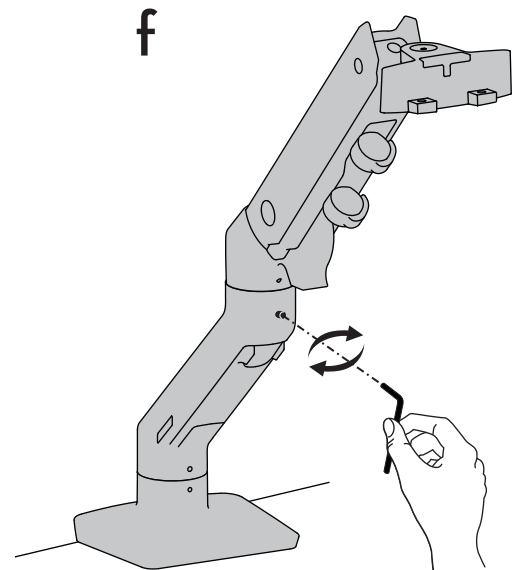
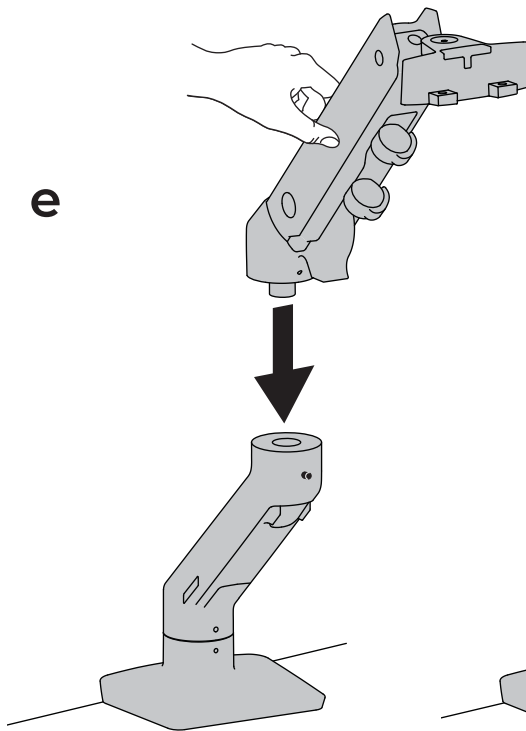
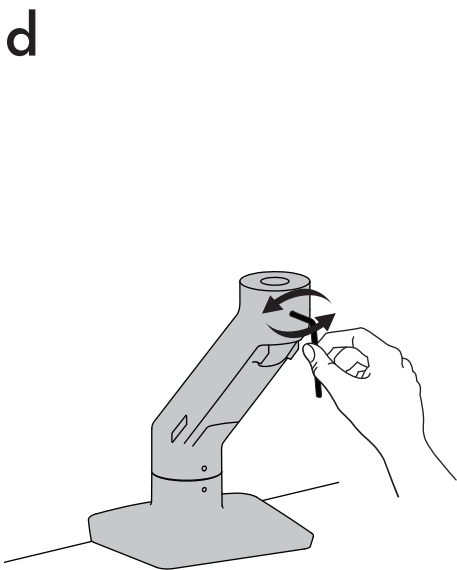
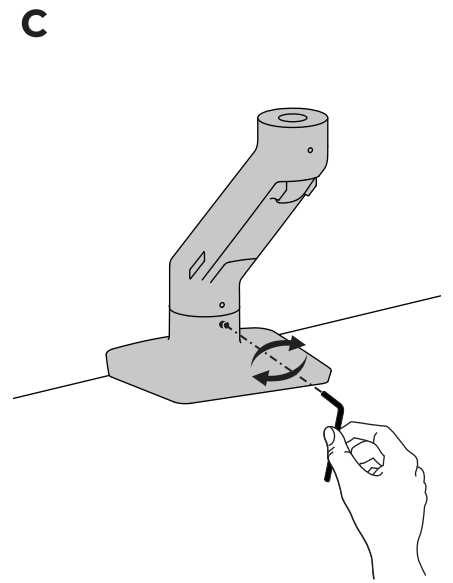
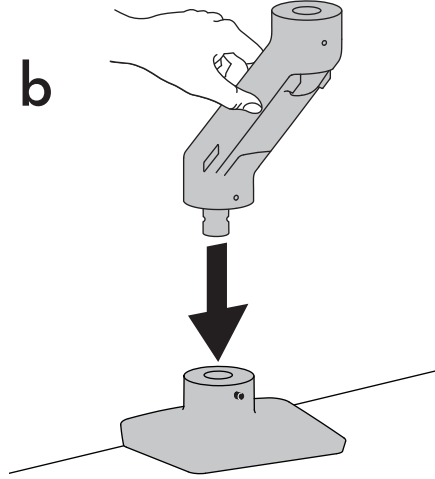
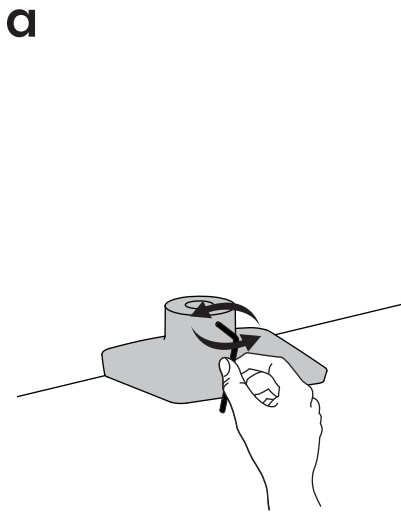

3

2x

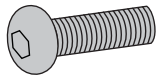

M6 x 14mm

2x



11.5 x 6.5 x 1



4mm

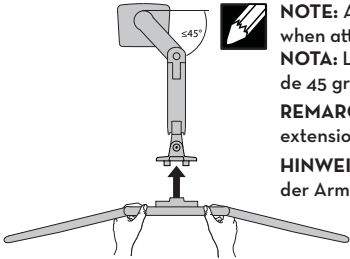

NOTE: Arm extension should be at a 45 angle or less when attaching crossbar.

NOTA: La extensión del brazo debe situarse en un ángulo de 45 grados o menos cuando se acople el la barra

REMARQUE: Lorsque le bras est fixé de la barre, son extension doit être de 45 degrés ou moins.

HINWEIS: Bei der Montage des Querschiene darf der Winkel der Armverlängerung maximal 45 Grad betragen.

注意:をクロスバー アームの延長部は45度以下の角度でなければなりません。

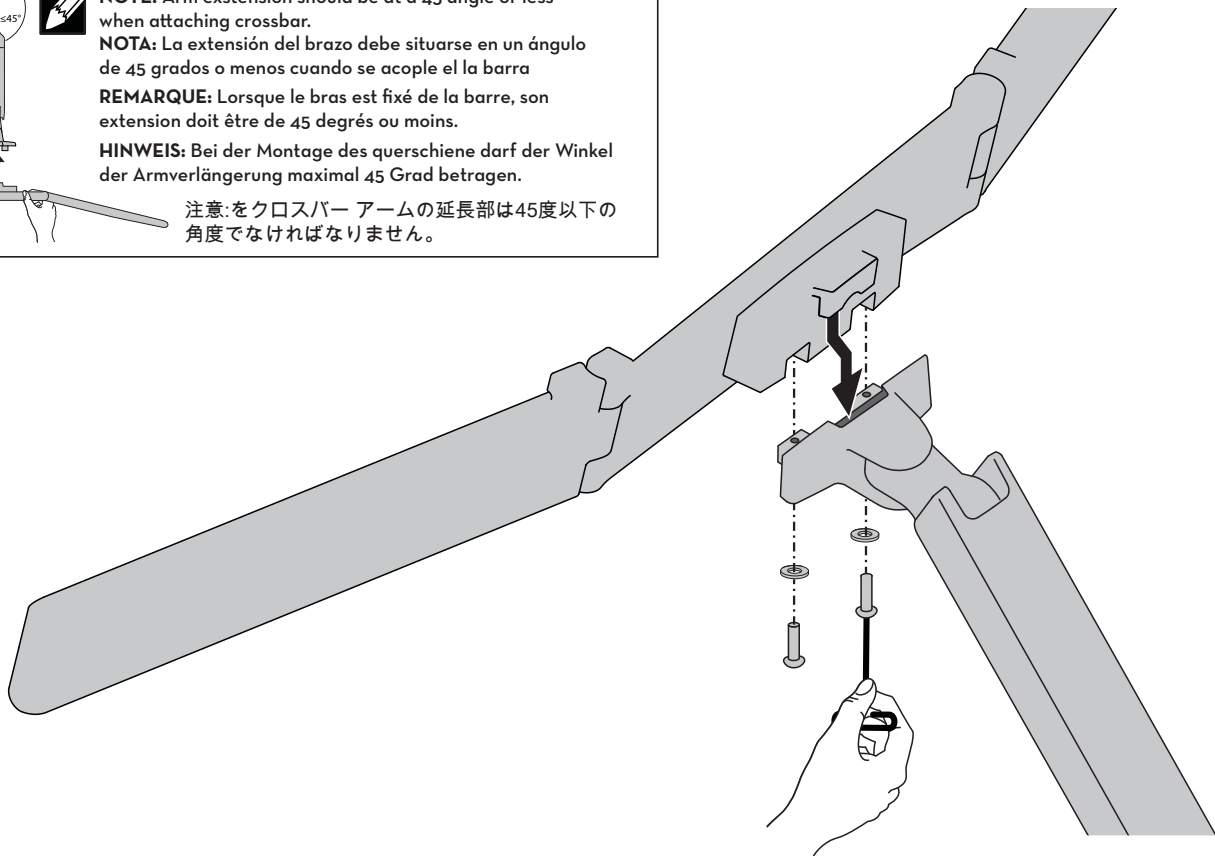

4

2x

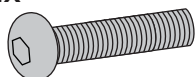

M6 x 22mm

2x

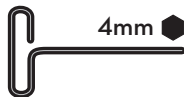
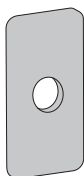

4mm

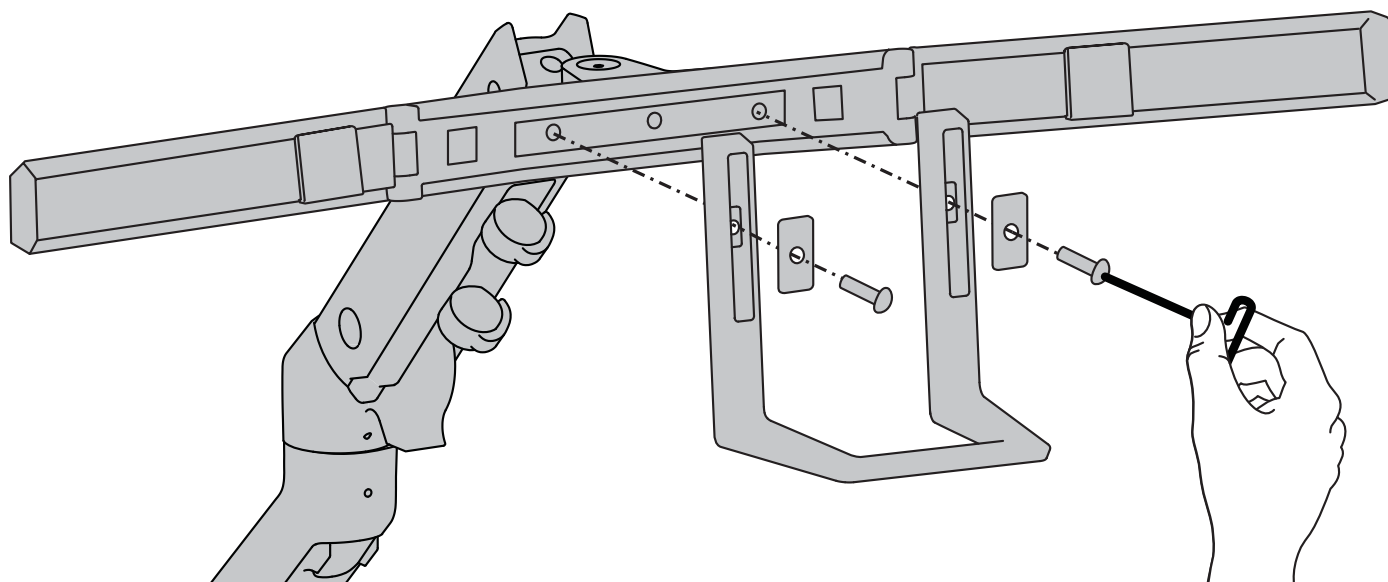

5 Level Crossbar
 Nivela la barra
 Niveau de la barre transversale
 Querschiene ausrichten.
 クロスバーを平らにする

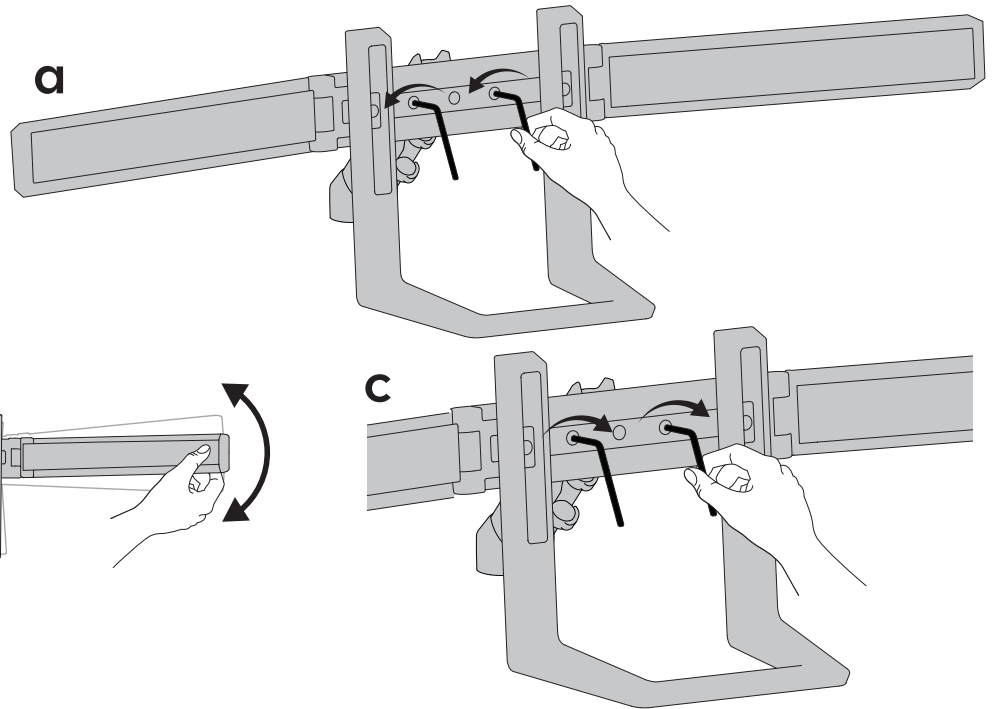

6

OPTIONAL: Insert stop screw to lock portrait/landscape monitor rotation.

OPCIONAL: Introduzca el tornillo de retención para bloquear la rotación horizontal/vertical del monitor.

FACULTATIF : Insérez la vis d'arrêt pour verrouiller la rotation portrait/paysage du moniteur.

OPTIONAL: Anbringen einer Arretierschraube, um die Quer- oder Hochformat-Drehung des Monitors zu verhindern.

オプション: 停止ネジを差込んで、モニターの高 / 横の回転をロックします。

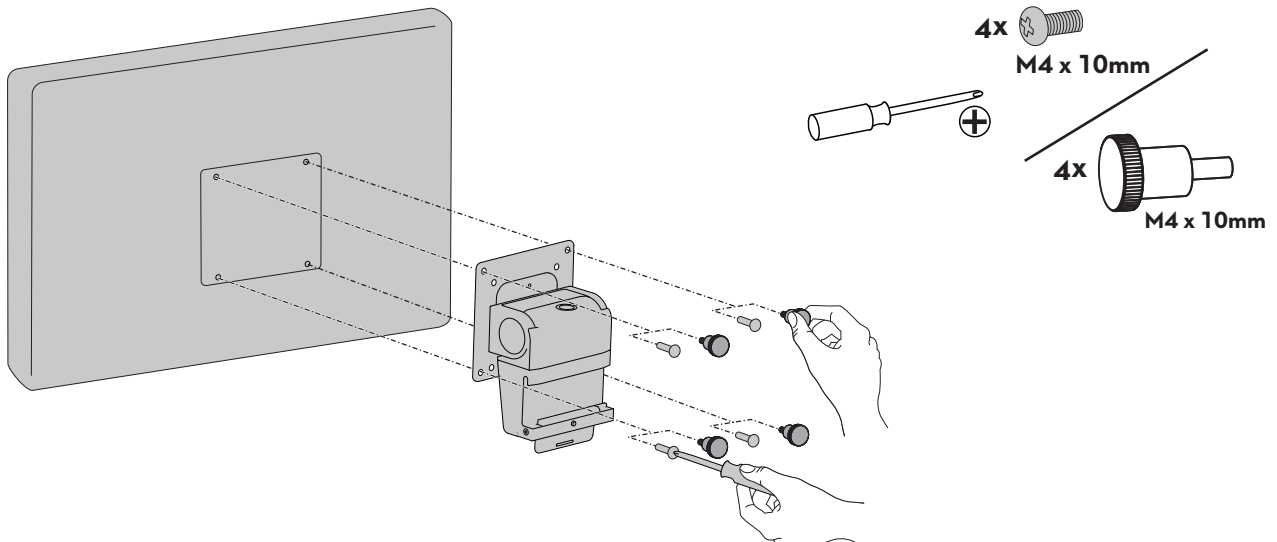
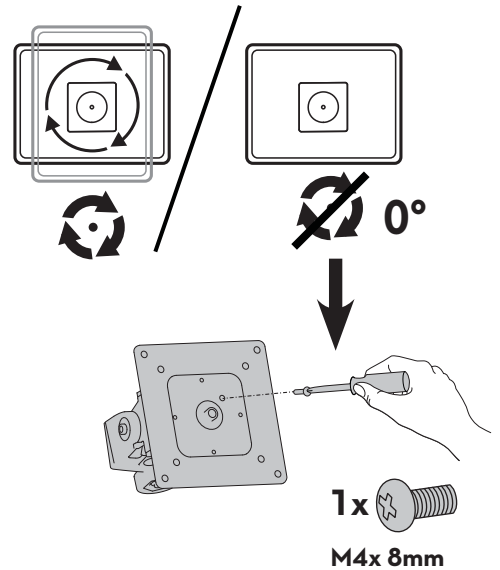

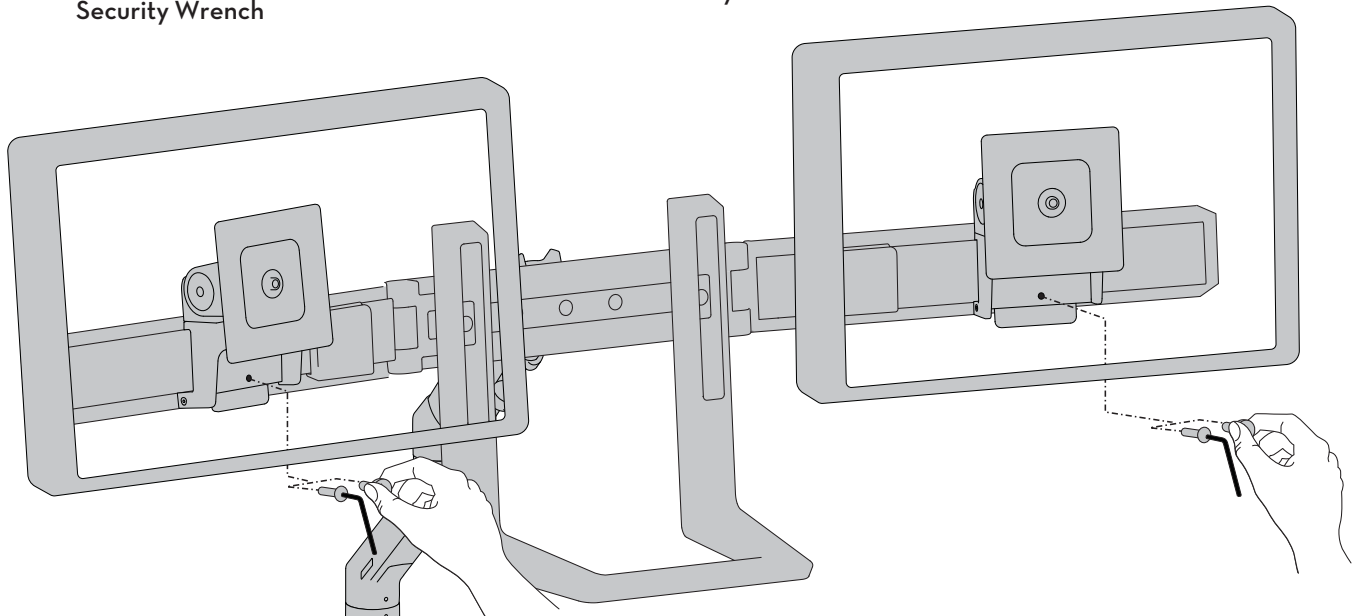
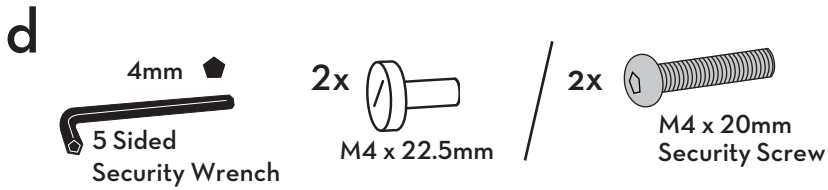
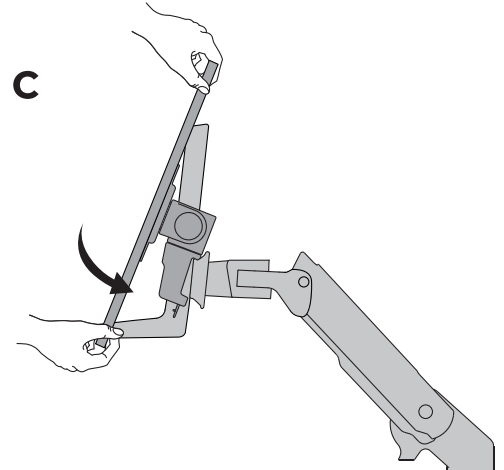
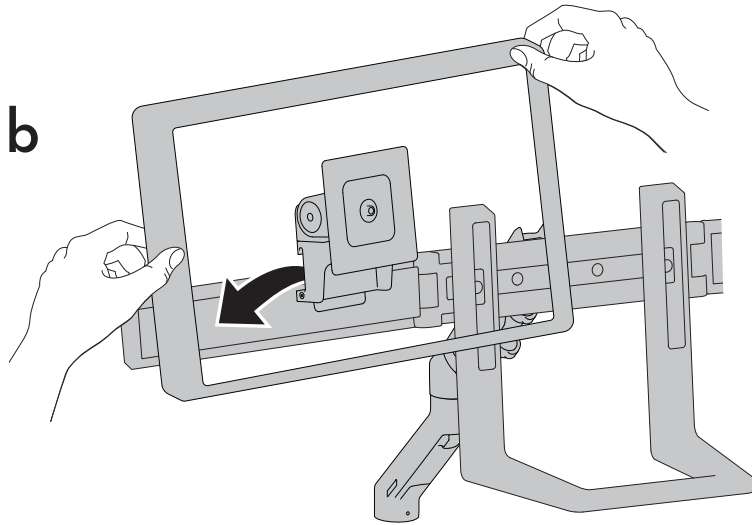
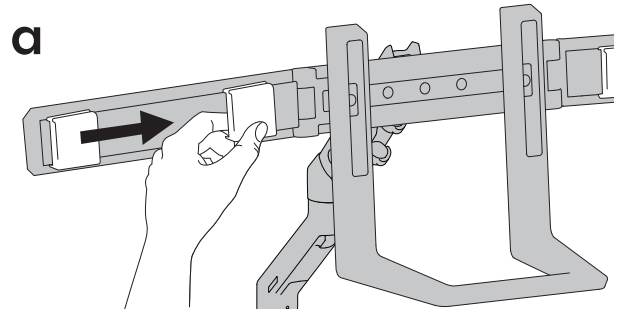

7 Attach monitors to crossbar.
 Acople los monitores a la barra.
 Fixez les moniteurs sur la barre transversale.
 Monitor an der Querschiene befestigen.
 モニターをクロスバーに取り付けます。



 CAUTION: Monitors are not stable unless fully secured to crossbar. Failure to tighten screws completely may result in damage to equipment.

 ATTENTION : Les moniteurs ne sont stables qu'une fois entièrement fixés à la barre transversale. Si vous ne serrez pas complètement les vis, il est possible que l'équipement soit endommagé.

 ATTENTION : Les moniteurs ne sont stables qu'une fois entièrement fixés à la barre transversale. Si vous ne serrez pas complètement les vis, il est possible que l'équipement soit endommagé.

 ACHTUNG: Die Monitore sind erst nach vollständigem Anziehen der Schrauben fest mit der Querschiene verbunden. Werden die Schrauben nicht vollständig angezogen, kann dies zur Beschädigung der Ausrüstung führen.

 注意: モニターはしっかりとクロスバーに固定されてない限り、安定しません。ネジを完全に締め付けないと、機器が破損することになるかもしれません。

8

2x

2x

a

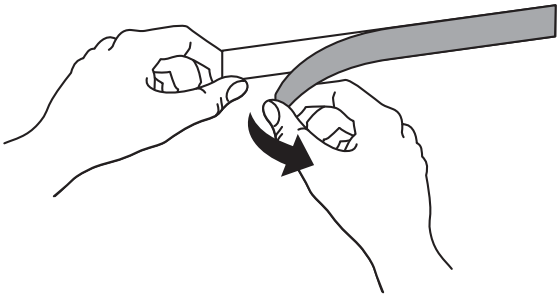

a

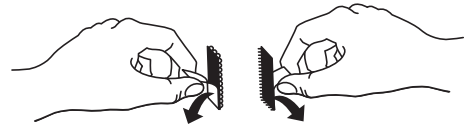

b

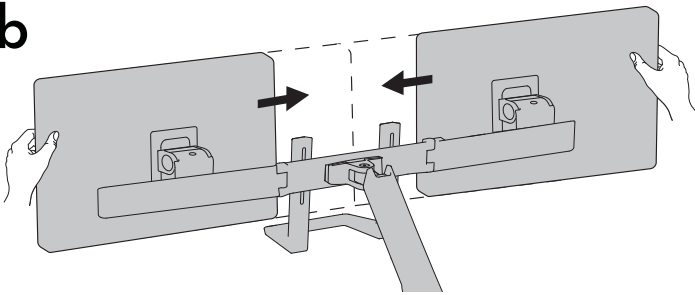

b

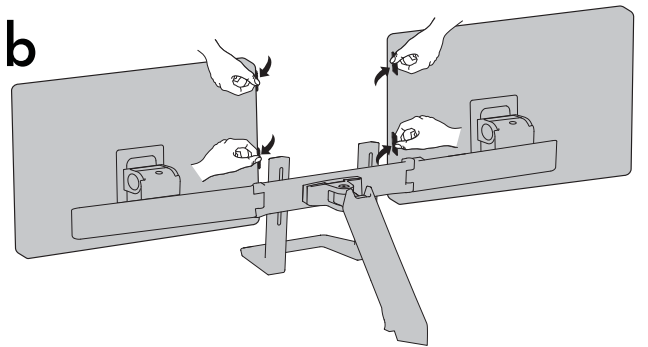

c

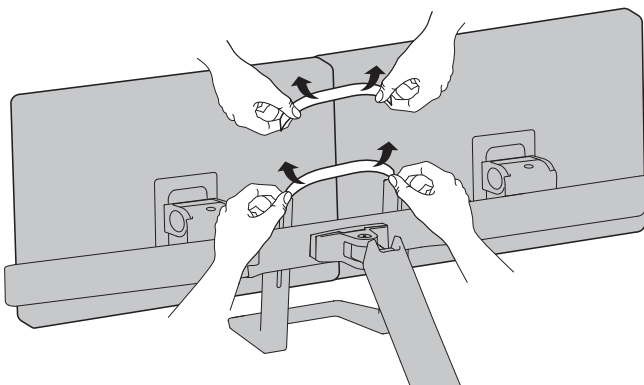

c

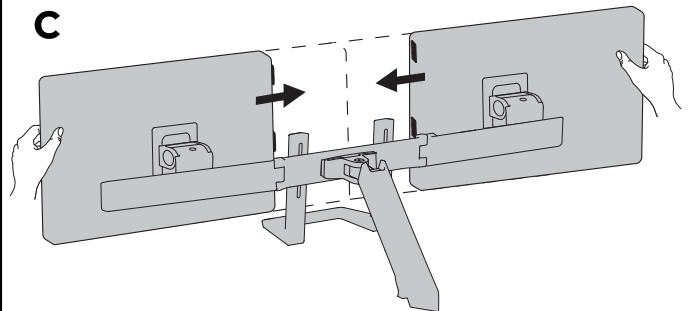

How to remove monitor from crossbar.
Cómo retirar los monitores de la cruceta
Comment démonter les moniteurs de la barre transversale
Wie Monitore vom Querträger entfernen
 モニターをクロスバーから取り外す方法

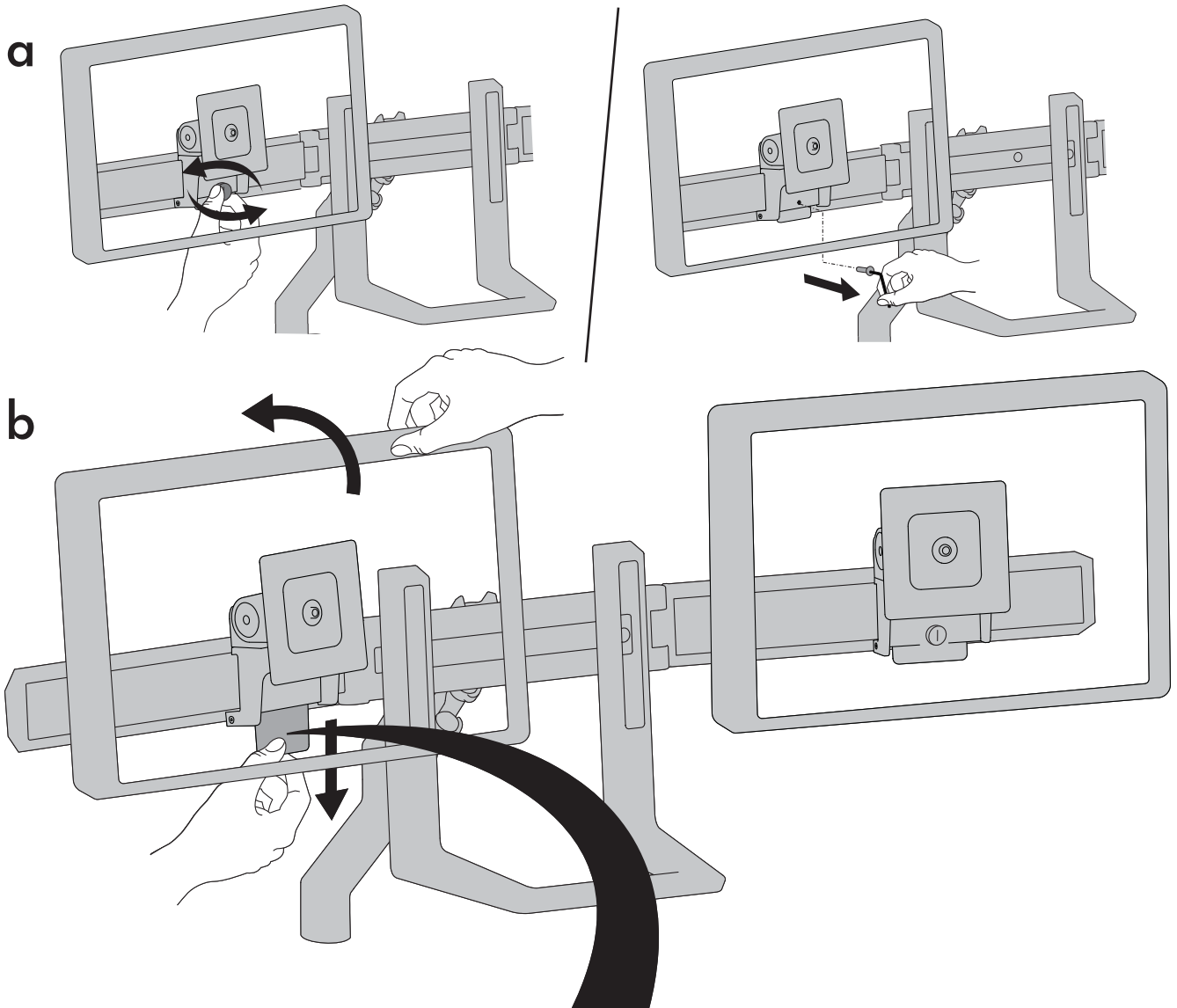
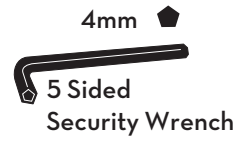

<p>i pull down tira hacia abajo tirer vers le bas nach unten ziehen 下げる</p>	<p>ii tilt incline incliner neigen 傾ける</p>	<p>iii pull off saque retirer wegziehen 引き抜く</p>
--	---	---

9



NOTE: Leave enough slack in cable to allow full range of motion.



Caution: To avoid the potential to pinch cables it is important to follow the cable routing instructions in this manual. Failure to follow these instructions may result in equipment damage or personal injury.



NOTA: Deje suficiente holgura en los cables para permitir su rango completo de movimiento.



Precaución: Para evitar la posibilidad de que se doblen los cables, es importante seguir las instrucciones de organización de los cables de este manual. En caso de no respetar estas instrucciones, podrían producirse daños en el equipo o lesiones físicas.



REMARQUE : Laissez suffisamment de mou dans le cordon pour permettre au mouvement de haut en bas de se faire sur toute la hauteur.



Attention : Pour éviter de risquer de pincer les câbles, il est important de suivre les instructions d'acheminement des câbles de ce manuel. Le non-respect de cette consigne peut entraîner des dommages matériels et/ou des blessures.



HINWEIS: Lassen Sie für das Kabel ausreichend Spielraum, um eine uneingeschränkte Bewegung zu gewährleisten.



Vorsicht: Damit keine Kabel eingeklemmt werden können, müssen Sie die Anweisungen zur Kabelführung in diesem Handbuch einhalten. Ein Missachten dieser Anweisungen kann zu Geräteschäden oder Verletzungen führen.



注: ケーブルが自由に動くよう、たるませた状態で配線します。



注意: ケーブルの挟まりを防ぐため、必ず本マニュアルのケーブル配線手順に従ってください。この指示に従わないと、機器の損傷や怪我を招く恐れがあります。

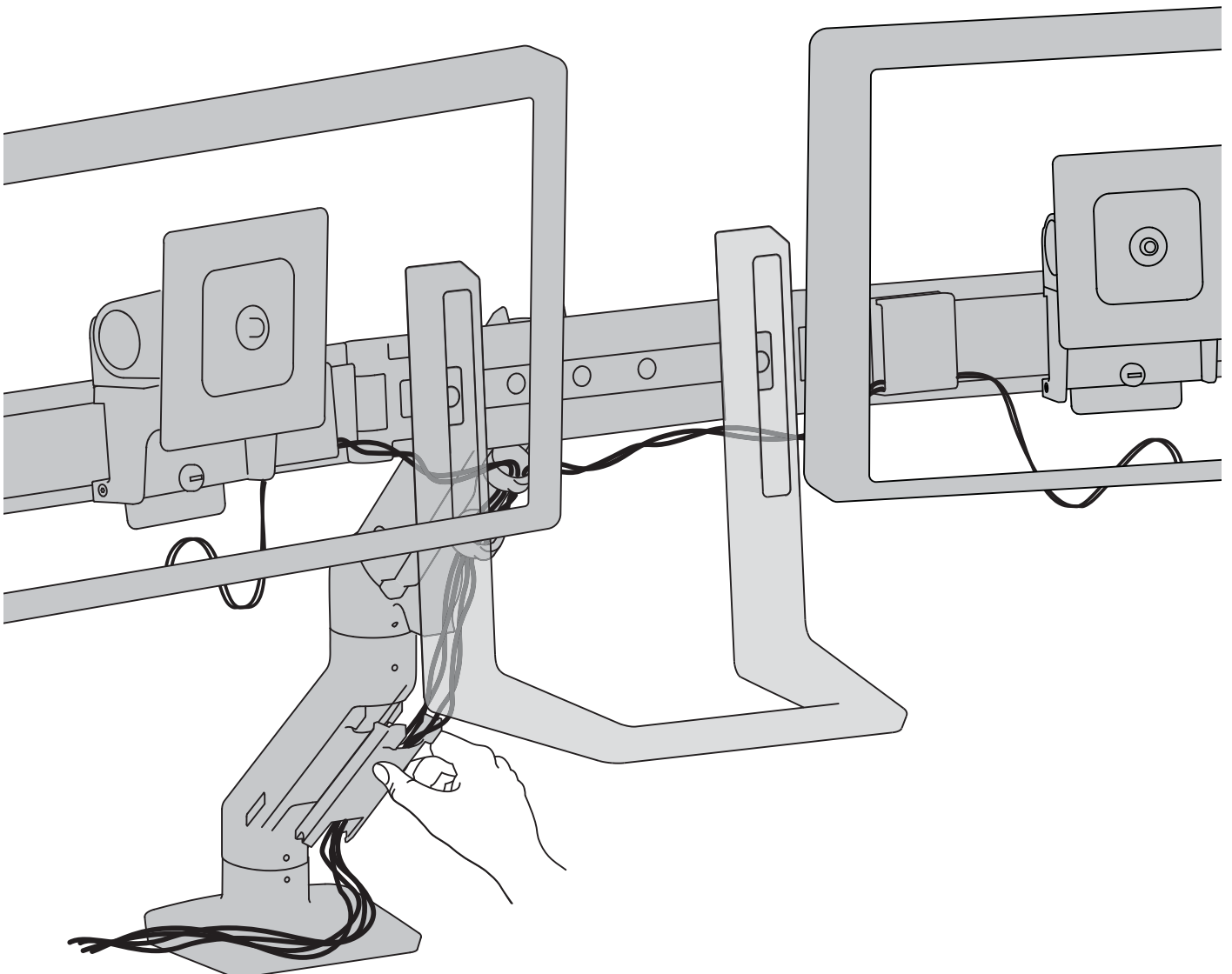

10

Important! You will need to adjust this product after installation is complete. Make sure all your equipment is properly installed on the product before attempting adjustments. This product should move smoothly and easily through the full range of motion and stay where you set it. If movements are too easy or difficult or if product does not stay in desired positions, follow the adjustment instructions to create smooth and easy movements. Depending on your product and the adjustment, it may take many turns to notice a difference. Any time equipment is added or removed from this product, resulting in a change in the weight of the mounted load, you should repeat these adjustment steps to ensure safe and optimum operation.

¡Importante! Tendrá que ajustar este producto una vez que haya terminado la instalación. Asegúrese de que todo su equipo esté instalado correctamente en el producto antes de intentar llevar a cabo algún ajuste. Este producto debe poder moverse de manera fácil y firme dentro de la amplitud de movimiento permitida y mantenerse donde usted lo fije. Si los movimientos son demasiado fáciles o difíciles o si el producto no se mantiene en las posiciones deseadas, siga las instrucciones de ajuste para conseguir movimientos suaves y fáciles. Dependiendo del producto y el ajuste, es posible que deba hacer muchos intentos hasta poder observar la diferencia. Cada vez que añada o retire equipos de este producto y que produzca un cambio en el peso de la carga, debe repetir estos pasos de ajuste para garantizar un funcionamiento seguro y óptimo.

Important ! Vous devez ajuster le produit une fois l'installation terminée. Assurez-vous que l'équipement est correctement installé sur le produit avant de procéder aux ajustements. Ce produit doit pouvoir être déplacé sans difficulté sur toute la plage de mouvement et rester immobilisé à l'endroit où il est réglé. Si le mouvement est trop facile ou trop difficile, ou si le produit ne reste pas dans les positions souhaitées, procédez selon les instructions de réglage pour harmoniser les mouvements. En fonction de votre produit et du réglage, plusieurs tours peuvent s'avérer nécessaire pour remarquer la différence. Chaque fois qu'une pièce d'équipement est ajoutée ou retirée de ce produit, affectant en conséquence le poids de la charge montée, vous devez répéter ces étapes de réglage afin de garantir une utilisation sécurisée et optimale du produit.

Wichtig! Sie müssen dieses Produkt nach dem Zusammenbau entsprechend einstellen. Achten Sie darauf, dass alle Ihre Geräte richtig auf dem Produkt installiert wurden, bevor Sie irgendwelche Einstellungen vorzunehmen versuchen. Dieses Produkt sollte sich in seinem gesamten Bewegungsbereich ruckfrei und ohne Schwierigkeiten bewegen lassen und an der Stelle bleiben, an der es abgestellt wird. Wenn die Bewegungen zu leicht oder nur mit großer Anstrengung durchgeführt werden können oder das Produkt nicht in der vorgesehenen Position bleibt, beachten Sie die Einstellanleitung, um ruckfreie und einfache Bewegungen zu ermöglichen. Je nach Ihrem Produkt und der jeweiligen Einstellung können zahlreiche Manipulationen erforderlich sein, bevor Sie einen Unterschied feststellen. Zur Sicherstellung einer sicheren und optimalen Produktfunktion sollten Sie diese Einstellschritte immer dann durchführen, wenn Geräte hinzugefügt oder entfernt werden, was eine Veränderung der Traglast zur Folge hat.

重要! 本製品は取り付け後に調整する必要があります。調整を行う前に、すべての機器が本製品に適切に取り付けられていることを確認してください。本製品は可動範囲内でスムーズかつ簡単に動く必要があり、選定した位置にしっかりと固定されなければなりません。製品が簡単に動きすぎる場合、動きがごこちない場合、あるいは目的の位置に固定されない場合は、説明書に従いスムーズに動くように調整してください。お使いの製品や調整によっては、違いがはっきりするまで何回か回さなければならないこともあります。本製品に機器を追加したり、機器を取り外したことで積載重量が変わった場合は、安全かつ最適な操作を実現するために調節手順を繰り返してください。

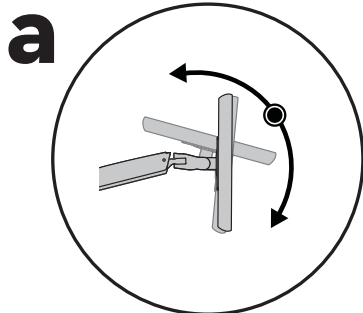

Tilt - Forward and Backward Inclinación (adelante y atrás) Inclinaison : Avant et arrière Neigung - vor und zurück チルト (前後)

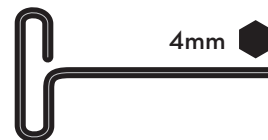

Increase Lift Strength
If the mounted weight is too heavy or this product does not stay up when raised, then you'll need to increase Lift Strength:

Aumentar la fuerza de elevación
Si el peso colocado es demasiado o si el producto no se mantiene arriba cuando se eleva, debe aumentar la fuerza de elevación:

Augmenter la force de levage
Si le poids installé est trop lourd ou si le produit ne reste pas en place une fois soulevé, vous devez augmenter la force de levage :

Hubkraft erhöhen
Wenn die installierten Geräte zu schwer sind oder das angehobene Produkt nicht oben bleibt, muss die Hubkraft erhöht werden:

リフト強度の増大
積載重量が重すぎる場合、または本製品の位置を上げてても下がってくる場合には、リフト強度を高める必要があります。



Decrease Lift Strength
If the mounted weight is too light or this product does not stay down when lowered, then you'll need to decrease Lift Strength:

Reducir la fuerza de elevación
Si el peso colocado es muy poco o si el producto no se mantiene abajo cuando se baja, tendrá que disminuir la fuerza de elevación:

Réduire la force de levage
Si le poids installé est trop faible ou si le produit ne reste pas en place une fois abaissé, vous devez réduire la force de levage :

Hubkraft senken
Wenn die installierten Geräte zu leicht sind oder das abgesenkte Produkt nicht unten bleibt, muss die Hubkraft reduziert werden:

リフト強度の低減
積載重量が軽すぎる場合、または本製品の位置を下げてても上がってくる場合には、リフト強度を弱める必要があります。

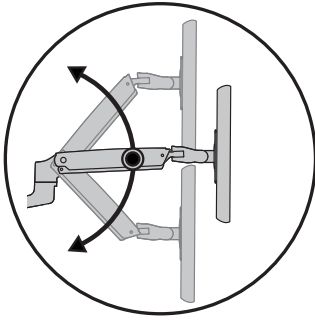
b

Lift - Up and down
 Elevación (arriba y abajo)
 Ajustement en hauteur : bas et haut
 Höhenverstellung - rauf und runter
 リフト(上下)

- 1** Raise arm to highest position.
 Levante el brazo hasta su posición más elevada.
 Soulevez le bras à sa position la plus haute.
 Arm auf höchste Position anheben.
 アームを一番高い位置まであげてください。

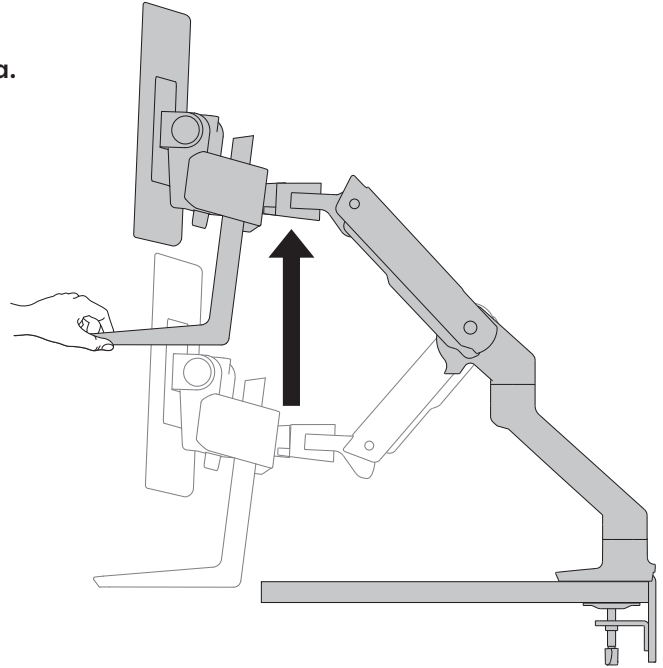
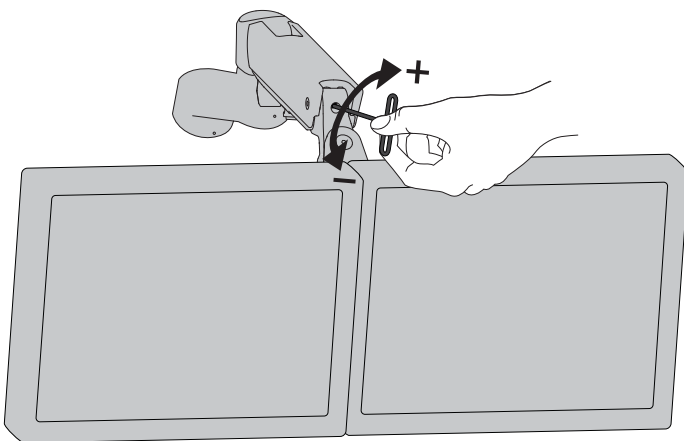
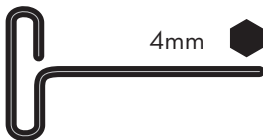
**2**

Increase Lift Strength
 If the mounted weight is too heavy or this product does not stay up when raised, then you'll need to increase Lift Strength:

Aumentar la fuerza de elevación
 Si el peso colocado es demasiado o si el producto no se mantiene arriba cuando se eleva, debe aumentar la fuerza de elevación:

Augmenter la force de levage
 Si le poids installé est trop lourd ou si le produit ne reste pas en place une fois soulevé, vous devez augmenter la force de levage :

Hubkraft erhöhen
 Wenn die installierten Geräte zu schwer sind oder das angehobene Produkt nicht oben bleibt, muss die Hubkraft erhöht werden:

リフト強度の増大
 積載重量が重すぎる場合、または本製品の位置を上げてても下がってくる場合には、リフト強度を高める必要があります。



Decrease Lift Strength
 If the mounted weight is too light or this product does not stay down when lowered, then you'll need to decrease Lift Strength:

Reducir la fuerza de elevación
 Si el peso colocado es muy poco o si el producto no se mantiene abajo cuando se baja, tendrá que disminuir la fuerza de elevación:

Réduire la force de levage
 Si le poids installé est trop faible ou si le produit ne reste pas en place une fois abaissé, vous devez réduire la force de levage :

Hubkraft senken
 Wenn die installierten Geräte zu leicht sind oder das abgesenkte Produkt nicht unten bleibt, muss die Hubkraft reduziert werden:

リフト強度の低減
 積載重量が軽すぎる場合、または本製品の位置を下げてても上がってくる場合には、リフト強度を弱める必要があります。

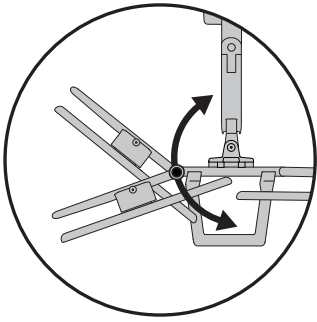
C

Crossbar Hinge Adjustment

Ajuste de bisagra de la cruceta

Ajustement de la charnière de la barre transversale

Einstellung des Scharniers der Querschiene

クロスバーのヒンジの調整

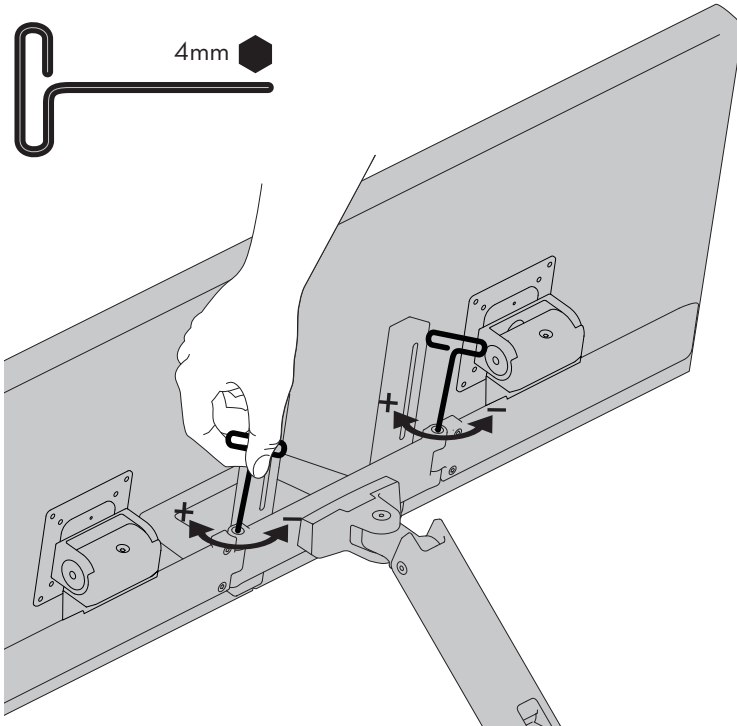

Increase Friction

If this product moves too easily, then you'll need to increase friction:

Aumentar la fricción

Si este producto se mueve con demasiada facilidad, tendrá que aumentar la fricción:

Augmenter le frottement

Si ce produit se déplace trop facilement, vous devrez augmenter la friction :

Reibung erhöhen

Wenn sich dieses Produkt zu leicht bewegen lässt, muss die Reibung erhöht werden:

摩擦力の増大

製品がわずかな力で簡単に動いてしまう状態であれば、摩擦力を高める必要があります。



Decrease Friction

If this product is too difficult to move, then you'll need to decrease friction:

Disminuir la fricción

Si resulta demasiado difícil mover este producto, tendrá que disminuir la fricción:

Réduire le frottement

Si ce produit est trop difficile à déplacer, vous devrez diminuer la friction :

Reibung senken

Wenn sich dieses Produkt nur unter großem Kraftaufwand bewegen lässt, muss die Reibung reduziert werden:

摩擦力の低減

製品がスムーズに動かない場合には、摩擦力を弱める必要があります。

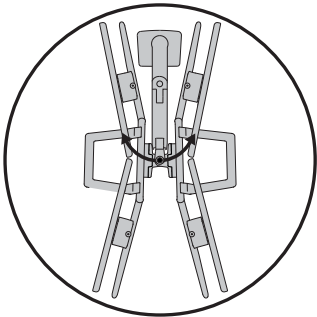
d

Crossbar Pan Adjustment

Ajuste de la rotación de la cruceta

Ajustement de l'orientation de la barre transversale

Einstellen der Schwenkfunktion der Querschiene

クロスバーパン調整

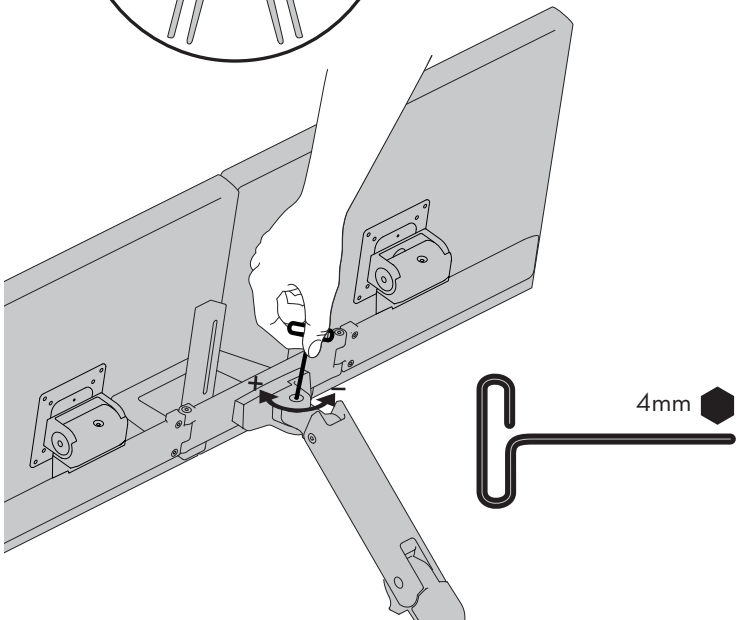

Increase Friction

If this product moves too easily, then you'll need to increase friction:

Aumentar la fricción

Si este producto se mueve con demasiada facilidad, tendrá que aumentar la fricción:

Augmenter le frottement

Si ce produit se déplace trop facilement, vous devrez augmenter la friction :

Reibung erhöhen

Wenn sich dieses Produkt zu leicht bewegen lässt, muss die Reibung erhöht werden:

摩擦力の増大

製品がわずかな力で簡単に動いてしまう状態であれば、摩擦力を高める必要があります。



Decrease Friction

If this product is too difficult to move, then you'll need to decrease friction:

Disminuir la fricción

Si resulta demasiado difícil mover este producto, tendrá que disminuir la fricción:

Réduire le frottement

Si ce produit est trop difficile à déplacer, vous devrez diminuer la friction :

Reibung senken

Wenn sich dieses Produkt nur unter großem Kraftaufwand bewegen lässt, muss die Reibung reduziert werden:

摩擦力の低減

製品がスムーズに動かない場合には、摩擦力を弱める必要があります。

e

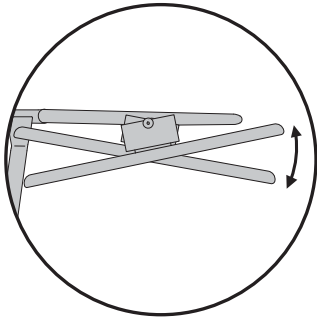

Monitor Pan Adjustment
 Ajuste de la rotación del monitor
 Ajustement de l'orientation du moniteur
 Einstellen der Schwenkfunktion des Monitors
 モニターパン調整

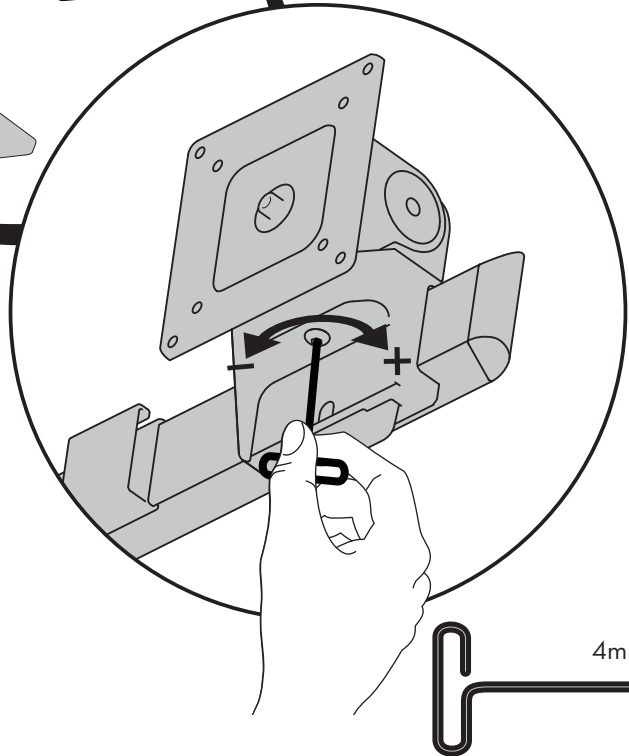
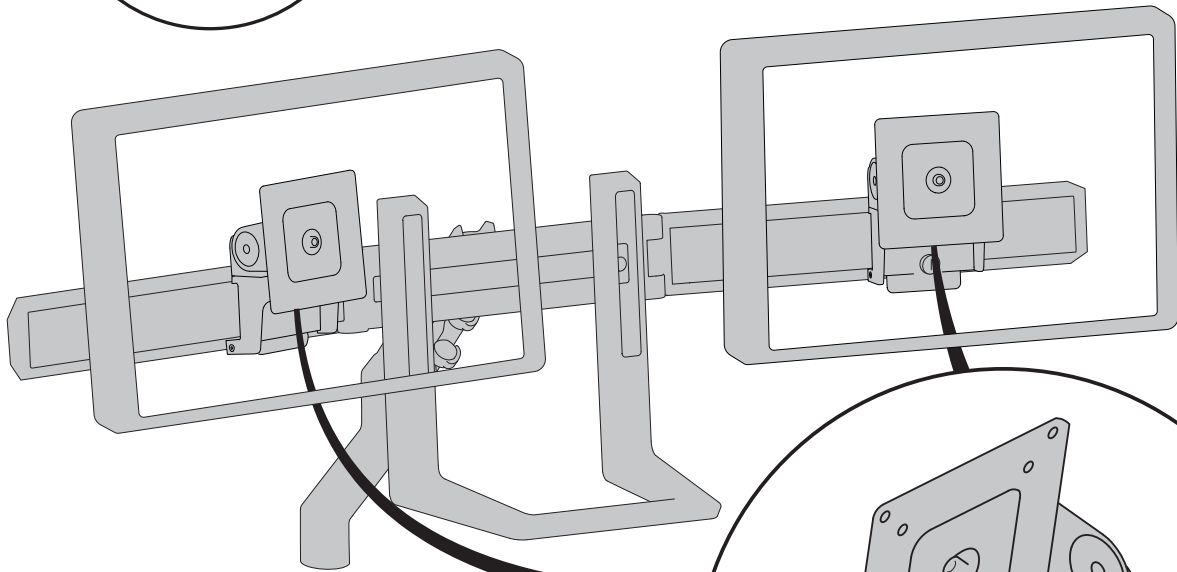

Increase Friction
 If this product moves too easily, then you'll need to increase friction:

Aumentar la fricción
 Si este producto se mueve con demasiada facilidad, tendrá que aumentar la fricción:

Augmenter le frottement
 Si ce produit se déplace trop facilement, vous devrez augmenter la friction :

Reibung erhöhen
 Wenn sich dieses Produkt zu leicht bewegen lässt, muss die Reibung erhöht werden:

摩擦力の増大
 製品がわずかな力で簡単に動いてしまう状態であれば、摩擦力を高める必要があります。



Decrease Friction
 If this product is too difficult to move, then you'll need to decrease friction:

Disminuir la fricción
 Si resulta demasiado difícil mover este producto, tendrá que disminuir la fricción:

Réduire le frottement
 Si ce produit est trop difficile à déplacer, vous devrez diminuer la friction :

Reibung senken
 Wenn sich dieses Produkt nur unter großem Kraftaufwand bewegen lässt, muss die Reibung reduziert werden:

摩擦力の低減
 製品がスムーズに動かない場合には、摩擦力を弱める必要があります。

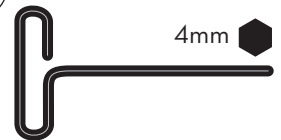

4mm

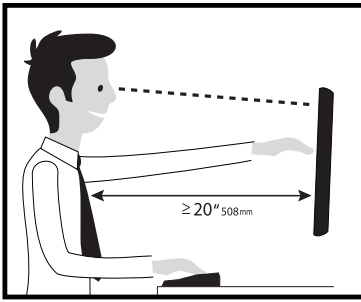

Ready to get moving on an active workstyle? Check out www.ergotron.com/tips to get started.

Learn more about ergonomic computer use at: www.ergotron.com/ergonomics

EN For the latest User Installation Guide please visit: www.ergotron.com
 For Warranty visit: www.ergotron.com/warranty
 For Service visit: www.ergotron.com
 For local customer care phone numbers visit: <http://contact.ergotron.com>

ES Para acceder a la última versión de la Guía de instalación para el usuario, ingrese a www.ergotron.com
 Para Garantía, visite: www.ergotron.com/warranty
 Para servicio, visite: www.ergotron.com
 Para conocer los números telefónicos locales de atención al cliente, visite: <http://contact.ergotron.com>

FR Pour la dernière version du Guide d'installation de l'utilisateur, visitez : www.ergotron.com.
 Pour la garantie, visitez: www.ergotron.com/warranty
 Pour le service client, visitez: www.ergotron.com
 Pour les numéros de téléphone du service client local, visitez : <http://contact.ergotron.com>

DE Die aktuellste Anleitung für die Montage durch den Benutzer finden Sie hier: www.ergotron.com
 Für Garantie Besuch: www.ergotron.com/warranty
 Für Servicebesuch: www.ergotron.com
 Örtliche Telefonnummern für den Kundendienst finden Sie hier: <http://contact.ergotron.com>

JA 最新のユーザー インストール ガイドは、www.ergotron.com でご確認くださいませ。
 保証書をご覧ください: www.ergotron.com/warranty
 サービスをご覧ください: www.ergotron.com
 最寄りのカスタマー ケアの電話番号については、こちらをご覧ください: <http://contact.ergotron.com>

EN NOTE: When contacting customer service, reference the serial number.

ES NOTA: Cuando se ponga en contacto con el servicio de atención al cliente, haga referencia al número de serie.

FR REMARQUE : Lorsque vous contactez le service à la clientèle, veuillez donner le numéro de série.

DE HINWEIS: Halten Sie bei der Kontaktaufnahme mit dem Kundendienst die Seriennummer griffbereit.

JA 注: カスタマー サービスにご連絡の際は、シリアル番号をお知らせください。

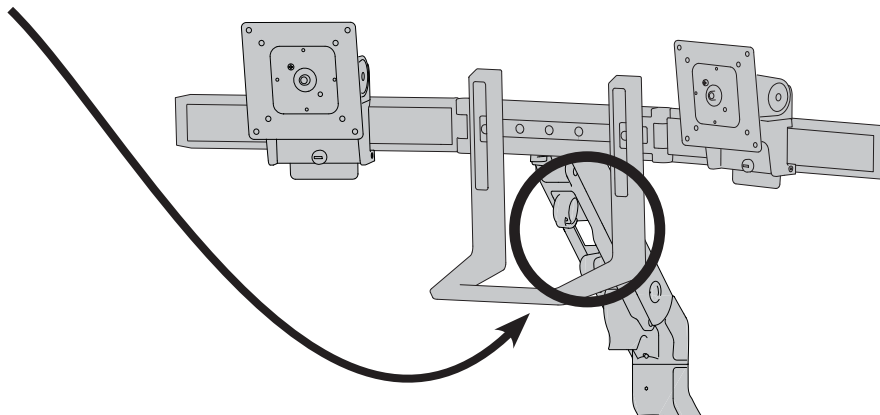

ergotron®

www.ergotron.com | USA: 1-800-888-8458 | Europe: +31 (0)33-45 45 600 | China: 400-120-3051 | Japan: japansupport@ergotron.com

© 2016 Ergotron, Inc. All rights reserved.

While Ergotron, Inc. makes every effort to provide accurate and complete information on the installation and use of its products, it will not be held liable for any editorial errors or omissions (including those made in the process of translation from English to another language), or for incidental, special or consequential damages of any nature resulting from furnishing this instruction and performance of equipment in connection with this instruction. Ergotron, Inc. reserves the right to make changes in the product design and/or product documentation without notification to its users. For the most current product information, or to know if this document is available in languages other than those herein, please contact Ergotron. No part of this publication may be reproduced, stored in a retrieval system, or transmitted in any form or by any means, electronic, mechanical, photocopying, recording or otherwise without the prior written consent of Ergotron, Inc., 1181 Trapp Road, Eagan, Minnesota, 55121, USA Patents Pending and Patented U.S. & Foreign. Ergotron is a registered trademark of Ergotron, Inc.

ergotron®

HX Desk Dual Monitor Arm

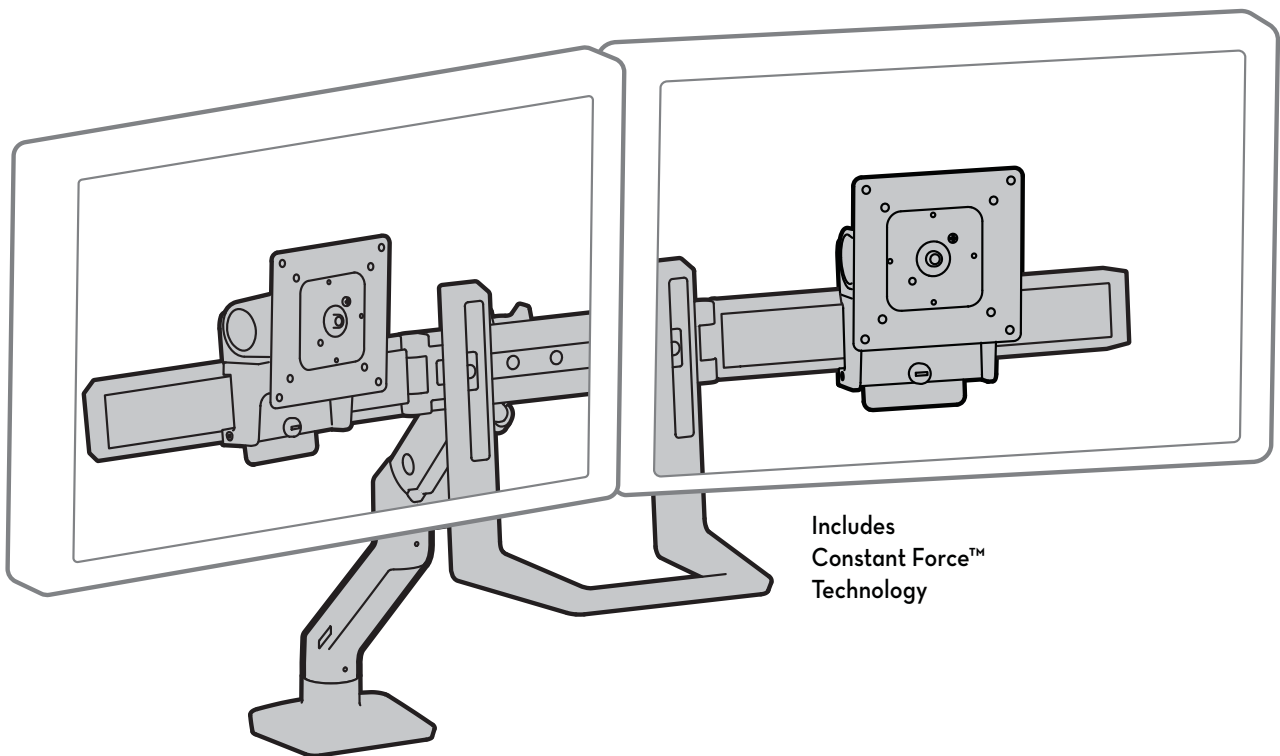

Includes
Constant Force™
Technology

ZH 用户指南

NL Benutzerhandbuch

IT Guida per l'utente

TR Kullanıcı Kılavuzu



www.ergotron.com: English, Español, Français, Deutsch, Nederlands, Italiano, Türkçe, 日本語, 汉语

www.ergotron.com | USA: 1-800-888-8458 | Europe: +31 (0)33-45 45 600 | China: 400-120-3051 | Japan: japansupport@ergotron.com

Overzicht symbolen voor gevaren

Deze symbolen waarschuwen gebruikers voor een veiligheidsomstandigheid waaraan aandacht besteed moet worden. Alle gebruikers moeten het belang van de volgende Veiligheidsgevaaren kunnen herkennen en begrijpen als zij daarmee geconfronteerd worden op het product of in de documentatie. Kinderen die de Veiligheidswaarschuwingen niet kunnen herkennen en niet op de juiste wijze daarop kunnen reageren mogen dit product niet gebruiken zonder toezicht van volwassenen!

Esame dei simboli di pericolo





Questi simboli avvisano gli utenti di una condizione di sicurezza che richiede attenzione. Tutti gli utenti devono essere in grado di riconoscere e comprendere il significato dei seguenti Pericoli per la sicurezza, se compaiono sul prodotto o all'interno della documentazione. I bambini non in grado di riconoscere e reagire nel modo appropriato ai Pericoli per la sicurezza non devono utilizzare questo prodotto senza la sorveglianza di un adulto!

Tehlike Simgelerinin Gözden Geçirilmesi

Bu simgeler dikkat gerektiren güvenlik durumları hakkında kullanıcıya uyarı vermektedir. Tüm kullanıcılar ürün üzerinde veya dokümanlarda karşılaşılabilecek halde aşağıda belirtilen Güvenlik Tehlikelerinin önemini bilmeli ve anlamalıdır. Güvenlik Uyarılarını doğru bir şekilde anlayamayan ve bunlara cevap veremeyen çocuklar erişkin gözetimi olmadan bu ürünü kullanmamalıdır!

危險标志回顾

这些标志提醒用户需要注意的安全状况。如果在产品上或者在文件中遇到以下标志，所有用户应能够识别和理解这些安全标志的含义。无法识别并对安全警报作出相应反应的儿童必须在成年人的监督下使用本产品！

Symbool Simbolo Simge 标志	Woordsignaal Indicazione di avvertenza İşaret Sözcüğü 信号文字	Gevarenniveau Livello di pericolo Tehlike Seviyesi 危险等级
	LET OP NOTA NOT 注	EEN OPMERKING geeft aan dat er belangrijke informatie is die u helpt dit product beter te gebruiken. Le NOTE contengono informazioni importanti per un uso migliore del prodotto. Bu ürünü daha iyi kullanmanızı sağlayan önemli bilgilerin yer aldığı NOT. “注”表示可以帮助您更好地使用本产品的重要信息。
	VOORZICHTIG ATTENZIONE DİKKAT 小心	VOORZICHTIG geeft aan dat er mogelijke schade kan ontstaan aan de hardware of verlies van data en vertelt u hoe het probleem te vermijden. Il simbolo ATTENZIONE segnala un potenziale danno all'hardware o la perdita di dati e spiega come evitare il problema. DİKKAT ifadesi donanımdaki olası hasarı veya veri kaybını göstermekte ve sorunu nasıl önleyeceğinizi açıklamaktadır. “小心”表示可能损坏硬件或丢失数据，告诉您如何避免。
	WAARSCHUWING AVVERTENZA UYARI 小心	Een WAARSCHUWING geeft aan dat er een kans is op beschadiging van apparatuur, verwonding van een persoon, of een dodelijk ongeluk. Le AVVERTENZE indicano la possibilità di danni agli oggetti, infortuni o morte. UYARI ifadesi mal hasarı, kişisel yaralanma veya ölüm riskini ifade etmektedir. “警告”表示潜在的财产损失、人员伤亡。
	ELEKTRISCH ELETTRICO ELEKTRİK 电气	Elektrisch geeft een kans op een elektrisch gevaar aan, dat - als het niet vermeden wordt - verwonding van een persoon, brand en/of overlijden tot gevolg kan hebben. L'indicazione Elettrico indica un pericolo elettrico incombente che, se non evitato, potrebbe causare infortuni, incendi e/o morte. Elektrik ifadesi, önlenmemesi halinde yaralanma, yangın ve/veya ölümle sonuçlanabilecek olası elektrik tehlikesini ifade etmektedir. “电气”表示可能的电气危险，如果不能避免，可能会导致人员受伤、火灾和/或死亡。



Belangrijk! U moet dit product bijstellen nadat de installatie voltooid is. Overtuig u ervan dat al uw apparatuur op de juiste wijze geïnstalleerd is op het product voordat u probeert bijstellingen uit te voeren. Dit product moet soepel en makkelijk bewegen door alle bewegingen en blijven staan waar u het zet. Als het te makkelijk of moeilijk beweegt of als het product niet in de gewenste posities blijft staan, volg dan de instructies voor het bijstellen om te zorgen voor soepele en makkelijke bewegingen. Afhankelijk van uw product en de bijstelling moet u mogelijk veel aan de schroeven en knoppen draaien om een verschil te merken. Elke keer als apparatuur toegevoegd of verwijderd wordt van dit product met als resultaat een verandering in het gewicht van de gemonteerde belasting, moet u deze stappen voor bijstelling opnieuw doorlopen om te zorgen voor een veilige en beste werking.

Importante! Al termine dell'installazione, sarà necessario regolare questo prodotto. Verificare che tutte le apparecchiature siano correttamente installate sul prodotto, prima di cercare di eseguire le regolazioni. Questo prodotto deve spostarsi in modo uniforme e scorrevole attraverso l'intero raggio di movimento, nonché restare fermo nel punto in cui viene collocato. Se gli spostamenti appaiono troppo agevoli o troppo difficoltosi, oppure se il prodotto non resta nelle posizioni previste, attenersi alle istruzioni sulla regolazione per ottenere spostamenti uniformi e scorrevoli. In base al prodotto e alla regolazione, è possibile che siano necessari molti giri per notare la differenza. Ogni volta che si aggiungono o tolgono apparecchiature dal prodotto, determinando una modifica nel peso del carico montato, occorre ripetere questi passaggi di regolazione, per garantire un funzionamento sicuro e ottimale.

Önemli! Montaj tamamlandıktan sonra bu ürün ayarlamamız gerekecektir. Ayarlamalar yapmadan önce tüm donanımınızın ürün üzerine düzgün şekilde monte edildiğinden emin olun. Bu ürün tüm hareket alanı boyunca düzgünce ve kolayca hareket etmeli ve ayarladığınız yerde kalmalıdır. Eğer hareketler çok kolay veya çok zorsa ya da ürün istenen konumlarda durmuyorsa, düzgün ve kolay hareketler oluşturmak için ayar talimatlarını izleyin. Ürünüze ve ayara bağlı olarak bir farkın tespiti için birçok dönüş gerekebilir. Monte edilen yükün ağırlığında bir değişikliğe yol açacak bir donanımı bu ürün üzerine eklediğiniz veya çıkardığınız zaman güvenli ve en uygun çalışmayı sağlamak üzere bu ayar adımlarını tekrarlamalısınız.

重要说明! 本产品安装完成后需要调节。在尝试进行调节之前，确保所有设备都正确安装在产品上。本产品应能在整个动作范围内灵活自如地移动，并能固定在所设定的位置。如果移动过于容易或过于困难，或者产品不能固定在想要的位置上，请按照调节说明操作，使动作灵活自如。根据您所用产品及调节方式，可能需要旋转几圈后才能注意到差别。每次添加或者从本产品上拆除设备时，都会使安装负荷重量发生变化，您应该重复调节步骤，确保运行状态安全、最佳。



Waarschuwing: Omdat materiaal voor de oppervlakken van bevestigingsstukken nogal verschillend kan zijn, is het van het grootste belang dat u ervoor zorgt dat het oppervlak van het bevestigingsstuk sterk genoeg is om daarop gezette producten en apparatuur te behandelen.

Avvertenza: poiché i materiali delle superfici di montaggio possono variare enormemente, è essenziale accertarsi che la superficie di montaggio sia abbastanza forte da poter sostenere il prodotto e l'apparecchiatura montati.

Uyarı: Montaj yüzeyi malzemeleri büyük ölçüde çeşitlilik gösterebileceğinden, montaj yüzeyinin monte edilen ürünü ve donanımı taşıyabilecek kadar güçlü olduğundan emin olmanız şarttır.

警告: 由于安装表面材质差异很大，必须确保安装表面足以支撑所安装的产品和设备。



Voorzichtig:

Om te voorkomen dat de snoeren mogelijk beklemd raken, dient u de instructies voor het leiden van de snoeren in dit handboek te volgen. Nalaten deze instructies te volgen kan de apparatuur beschadigen of persoonlijk letsel veroorzaken.

Attenzione:

Per evitare la possibilità di schiacciare i cavi, è importante seguire le istruzioni di instradamento dei cavi riportate nel presente manuale. La mancata osservanza delle presenti istruzioni può causare danni alle cose o infortuni personali.

Dikkat:

Kablolarda sıkışma olasılığını önlemek için bu el kitabındaki kablo yönlendirme talimatlarına uymak önemlidir. Bu talimatlara uyulmaması donanımda hasar ve/veya kişisel yaralanmayla sonuçlanabilir!

小心:

为了避免夹住线缆，请务必遵守本手册中的布线说明。不遵守本警告指示可能导致设备损坏或人身伤害。



WARNUNG! Gefährdung durch gespeicherte Energie: Der Arm-Mechanismus der Arbeitsfläche steht unter Spannung und bewegt sich von allein und schnell nach oben, sobald das befestigte Gerät abgenommen wird. Entfernen Sie aus diesem Grund die Geräte nur, wenn sich der Arm auf der höchsten Position befindet! Eine Missachtung dieser Anweisung kann zu ernsthaften Verletzungen und/oder Beschädigungen am Gerät führen.

AVVERTENZA! Gevaar door opgeslagen energie: het hefmechanisme van het werkoppervlak staat onder spanning en verplaatst zich zelfstandig snel omhoog wanneer de bevestigde apparatuur wordt verwijderd. Verwijder apparatuur daarom ALLEEN nadat de arm in de hoogste stand is gezet! Als u deze instructie niet opvolgt, kan dit tot ernstig persoonlijk letsel en/of beschadiging van de apparatuur leiden!

UYARI! Depolanmış Enerji Tehlikesi: Kol mekanizması gerilmiş durumdadır ve takılmış olan donanım çıkarıldığı an kendi kendine hızla yukarı doğru hareket edecektir. Bu nedenle kol en yüksek konuma taşınmadığı sürece donanımı ÇIKARMAYIN! Bu talimata uyulmaması ciddi kişisel yaralanma ve/veya donanım hasarıyla sonuçlanabilir!

警告！ 储能危险：支臂机构处于受力状态，在拆除所安装的设备后会自行快速上升。因此，在将支臂移到最高位置之前，不要拆除设备！不遵守本规定可能导致严重的人身伤害和/或设备损坏！

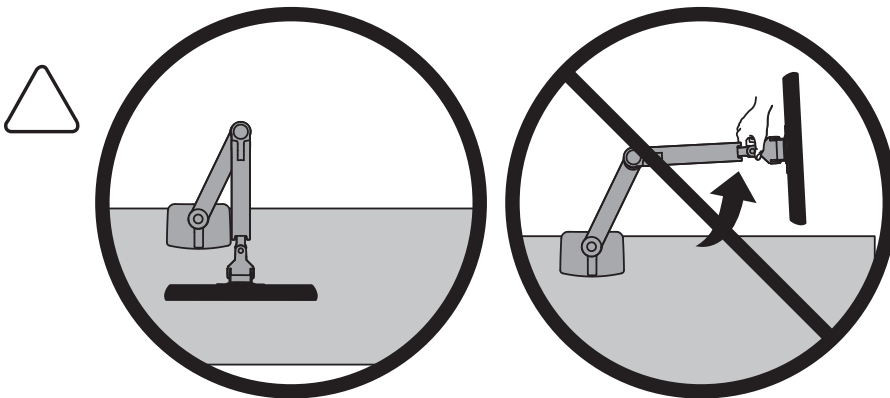

VOORZICHTIG: De monitor NIET buiten de rand van het werkblad draaien. Dat veroorzaakt een onstabiele situatie en kan leiden tot beschadiging van de apparatuur of persoonlijke verwonding.

ATTENZIONE: NON ruotare il monitor oltre il bordo posteriore della scrivania. Tale operazione causerebbe una situazione instabile e potrebbe causare danni all'apparecchiatura o infortuni personali.

DİKKAT: Monitörü tablanın arka kenarından geçecek şekilde DÖNDÜRMEYİN. Bunu yapmanız sabit olmayan bir durum oluşturacaktır ve donanım hasarına ve/veya kişisel yaralanmaya neden olabilir.

注意： 请勿将显示器旋转超出工作台尾部边缘。否则显示器不稳固，可能会造成设备损坏或人身伤害。

Kenmerken en specificaties
Caratteristiche e dati tecnici
Nitelikler ve Teknik Özellikler
特点和规格

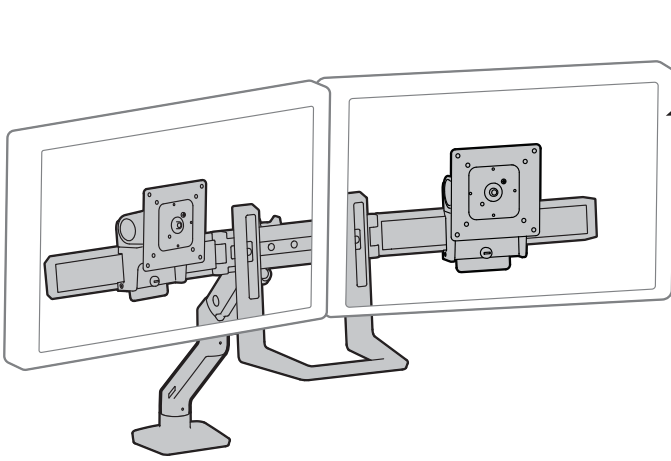

5 lbs. (2.3 kg) - 17.5 lbs. (7.9 kg)

VOORZICHTIG: OVSCHRIJD DE MAXIMUM OPGEGEVEN
GEWICHTSCAPACITEIT NIET. DIT KAN LEIDEN TOT ERNSTIGE
VERWONDINGEN OF BESCHADIGING VAN BEZIT.

ATTENZIONE: NON SUPERARE LA CAPACITÀ DI CARICO MASSIMA
INDICATA. POTREBBERO VERIFICARSI INFORTUNI O DANNI AGLI
OGGETTI!







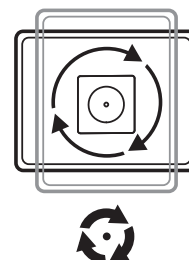
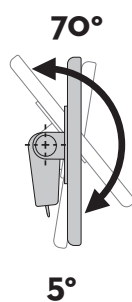
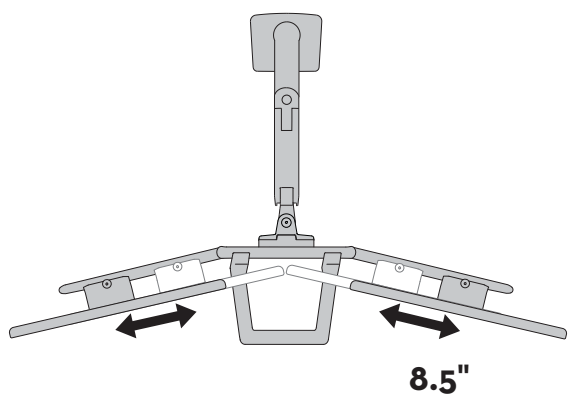
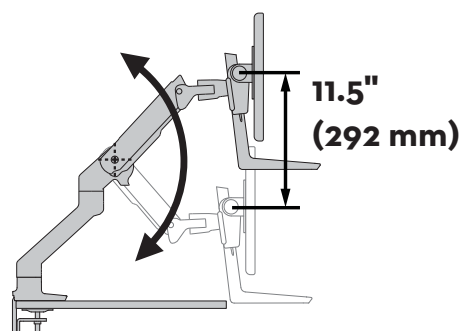
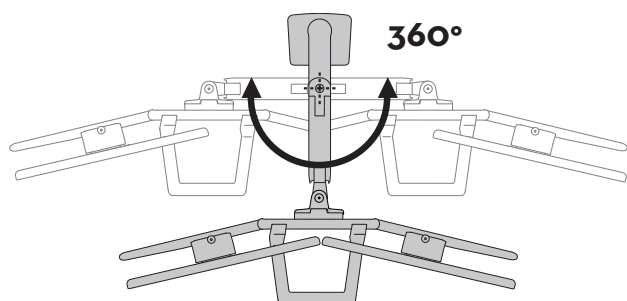
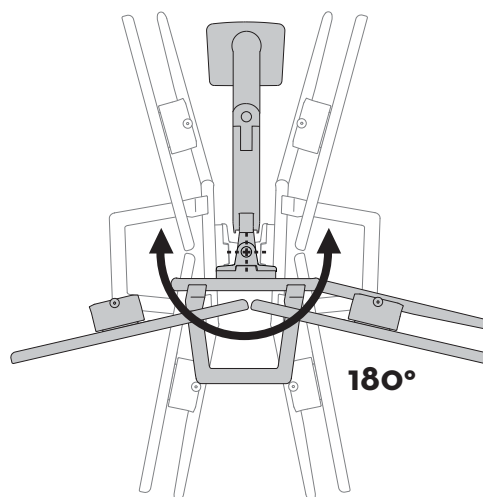
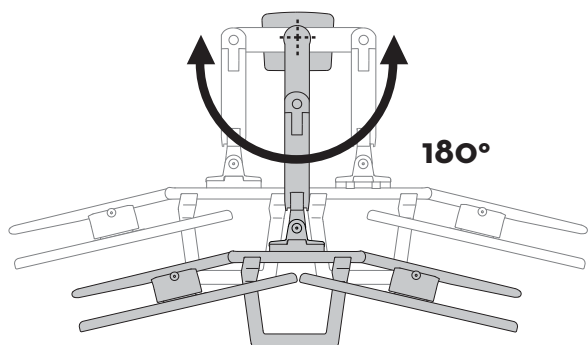
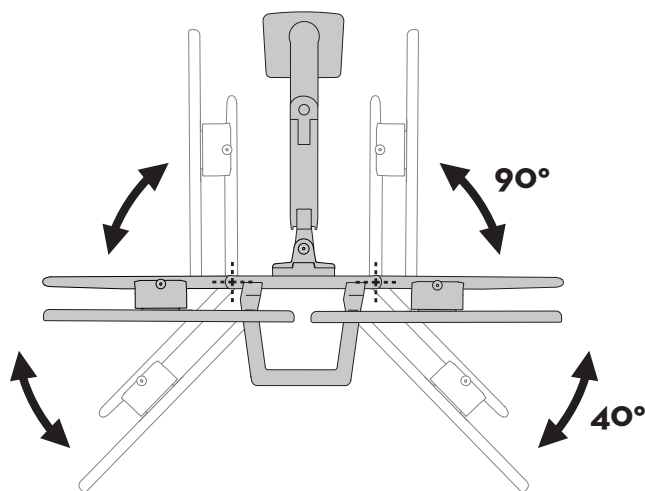
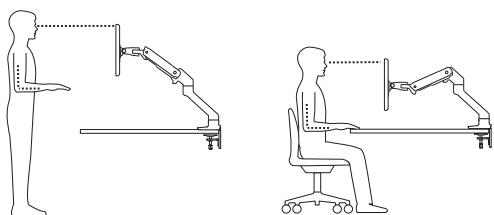



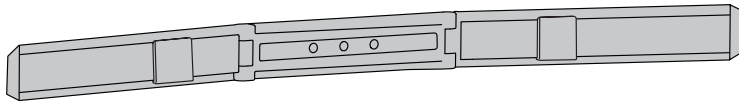
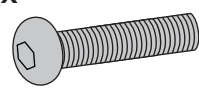
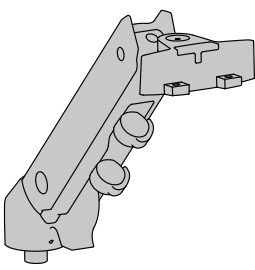
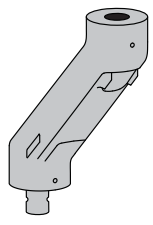
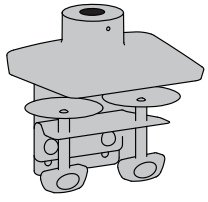
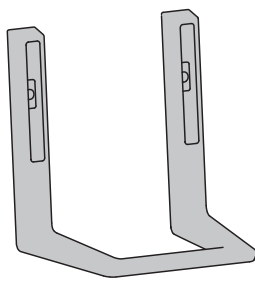

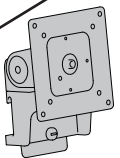
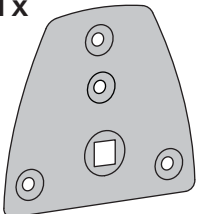
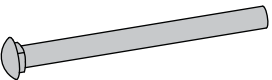
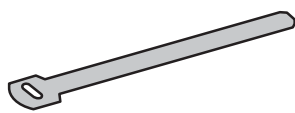

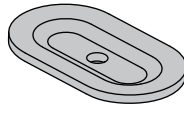
DİKKAT: BELİRTİLEN EN YÜKSEK AĞIRLIK SINIRINI AŞMAYIN. CİDDİ
YARALANMA VEYA MAL HASARI OLUŞABİLİR!

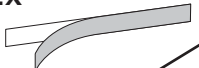
注意：请勿超过所列的最大可承重量。否则可能导致重伤或设备损坏！

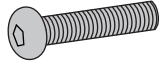
Kenmerken en specificaties
Caratteristiche e dati tecnici
Nitelikler ve Teknik Özellikler
特点和规格

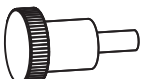
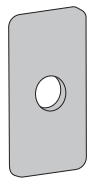

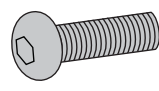

	A	B	C	D
1	1x 			2x  M6 x 22mm
2	1x 	1x 	1x 	1x 
3	2x  M4 x 8mm 2x 	1x 	1x  M10 x 95mm	2x 
4	2x  M4 x 22.5mm	1x  M10	1x 	2x  11.5 x 6.5 x 1
5	2x  2x 	2x Security Screw  M4 x 20mm	8x  M4 x 10mm 8x  M4 x 10mm	2x 
6	1x  4mm	1x  2.5mm	1x  4mm 5 Sided Security Wrench	2x  M6 x 14mm

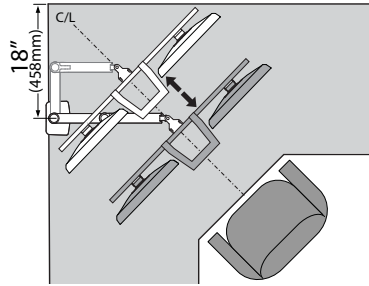
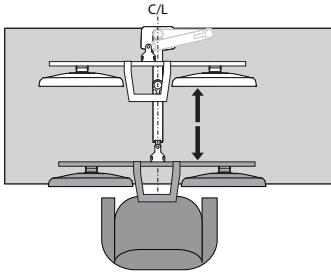
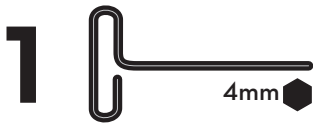

LET OP: bepaal voor het installeren of de arm mees-
tal naar links of naar rechts zal kantelen.

NOTA: prima dell'installazione, verificare se il braccio
tenderà a cadere verso sinistra o destra.

NOT: Kolun kurulum öncesinde sola veya sağa düşüp
düşmeyeceğini belirleyin.

注意：在安装之前，请检查支臂是否会向左或向右
塌陷。

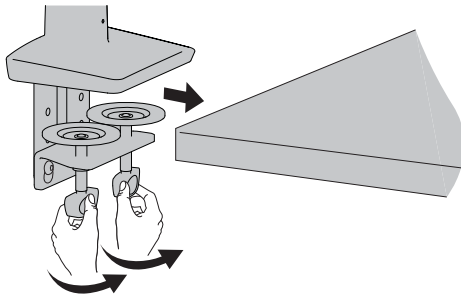
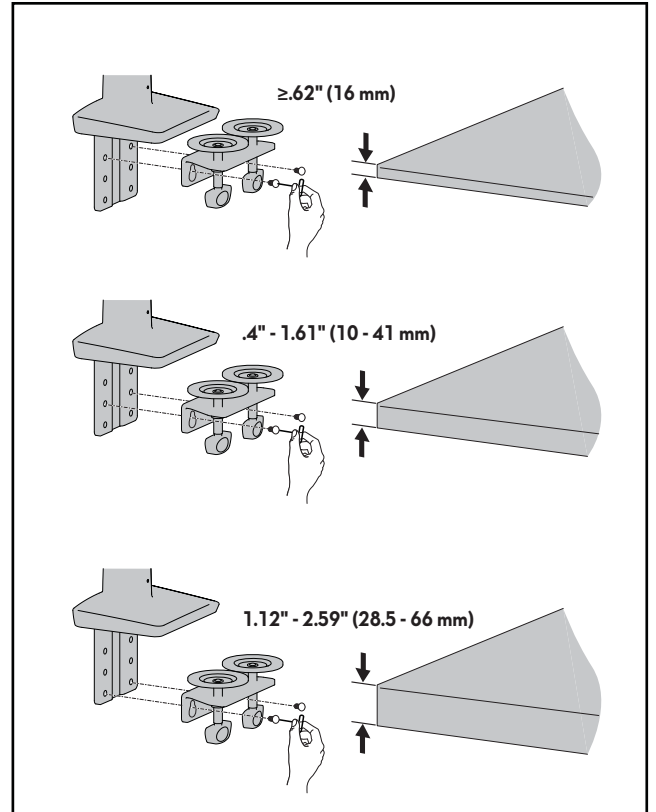

Optioneel: Doorvoer Ophangsystem

Facoltativo: Installazione con foro passante

İSTEĞE BAĞLI: Simit Halkası Yuvasının Montajı

可选：安装垫圈支架

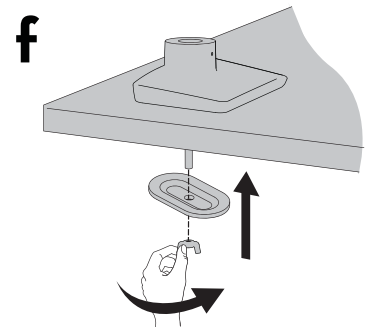
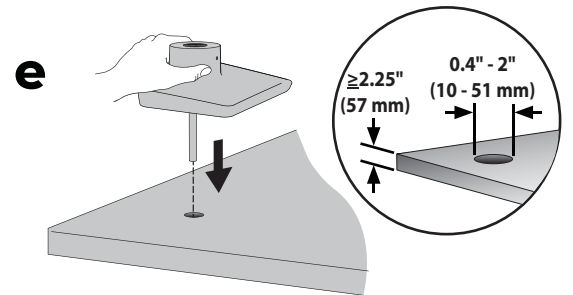
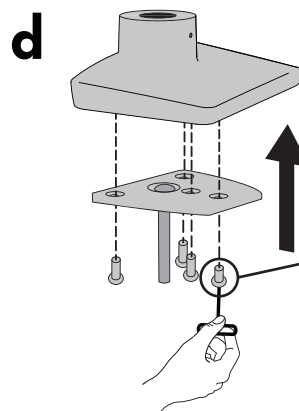
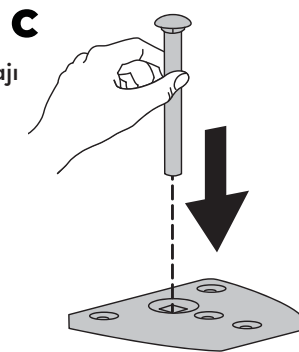
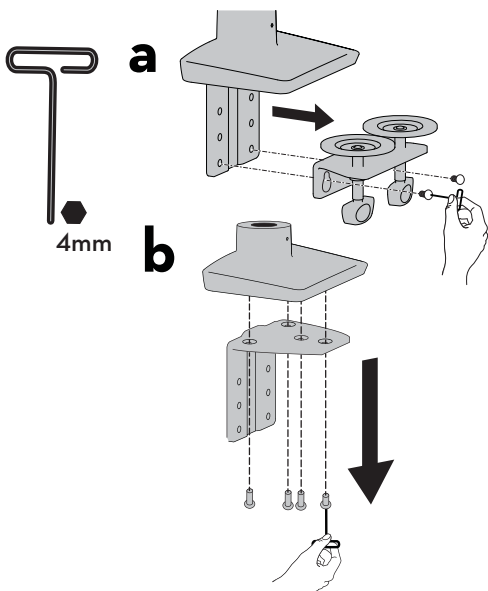

Opmerking: de korte schroef moet opnieuw in het voorste gat van
de doorvoerklem aangebracht worden.

NOTA: la vite corta deve essere reinserita nel foro anteriore del
montaggio dell'anello passacavo.

NOT: Kısa vida, simit halkası yuvasının ön deliğine yerleştirilmelidir.

注意：短螺丝须重新安装在垫圈安装架的前孔中。

2  2.5mm

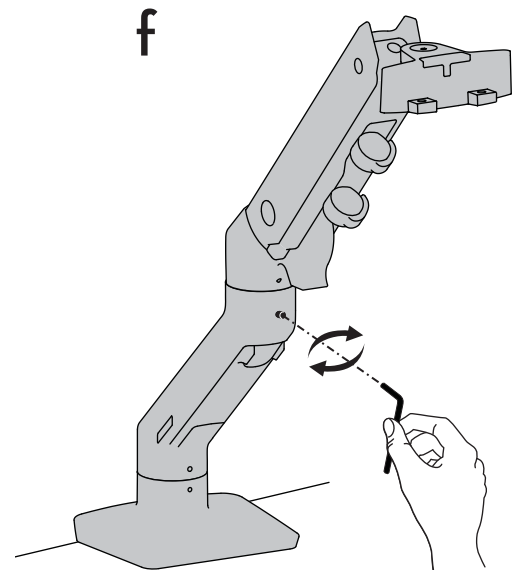
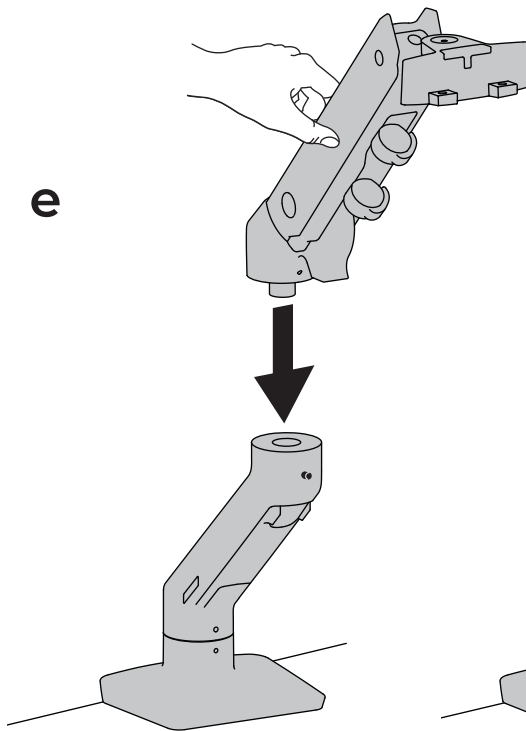
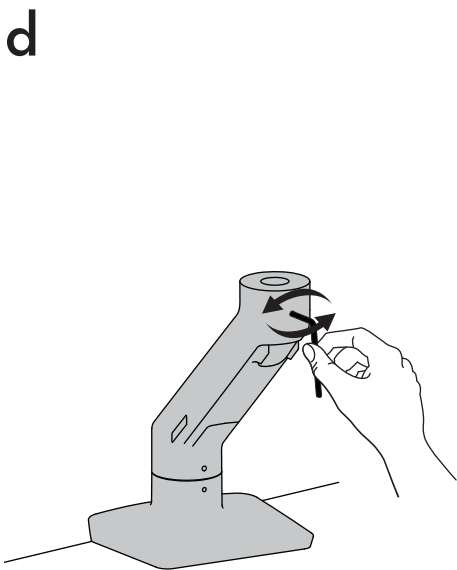
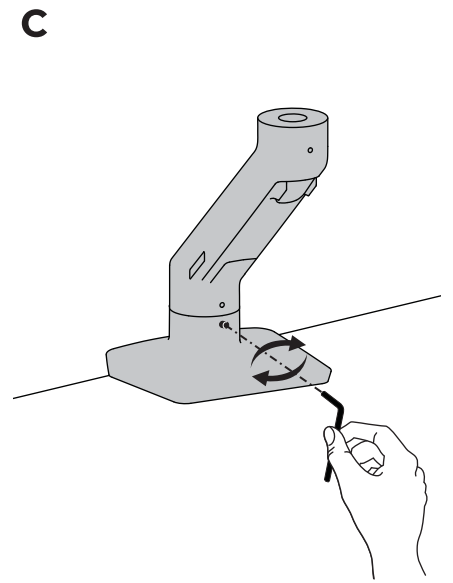
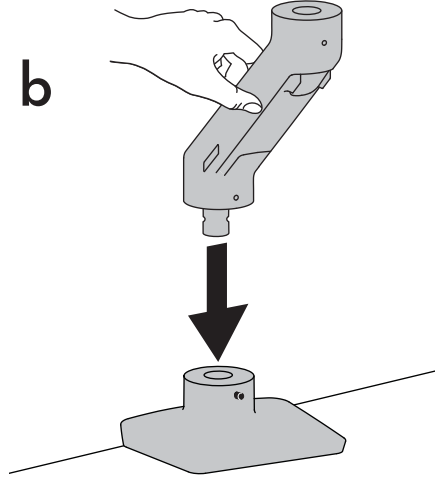
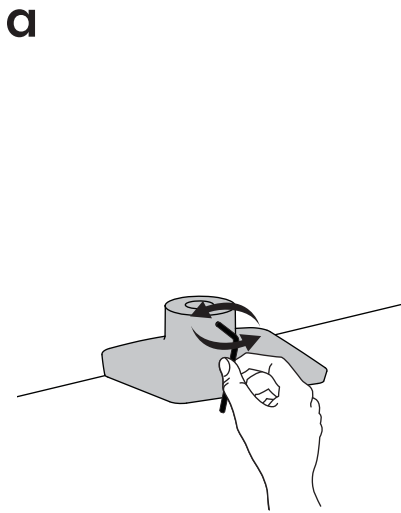

3

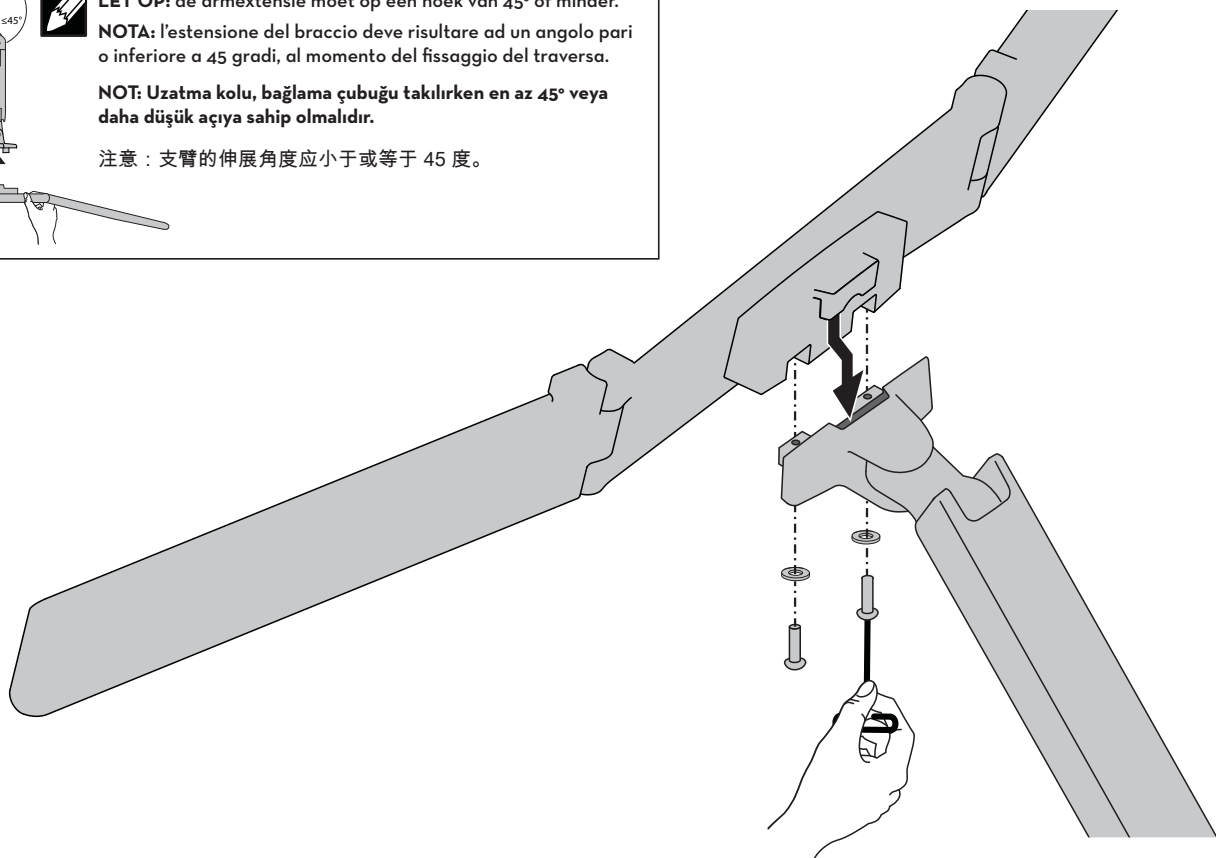
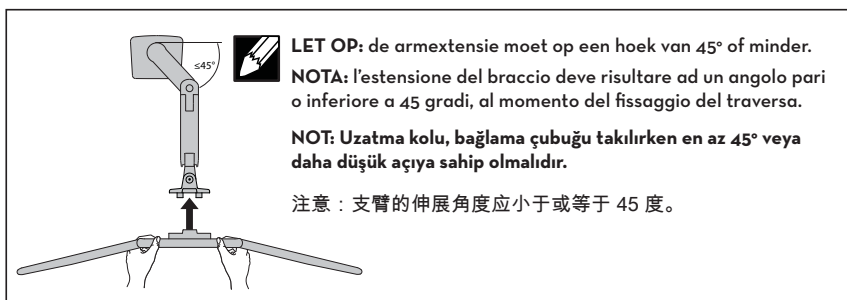
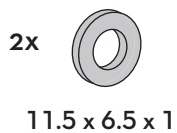
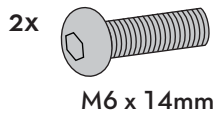

4

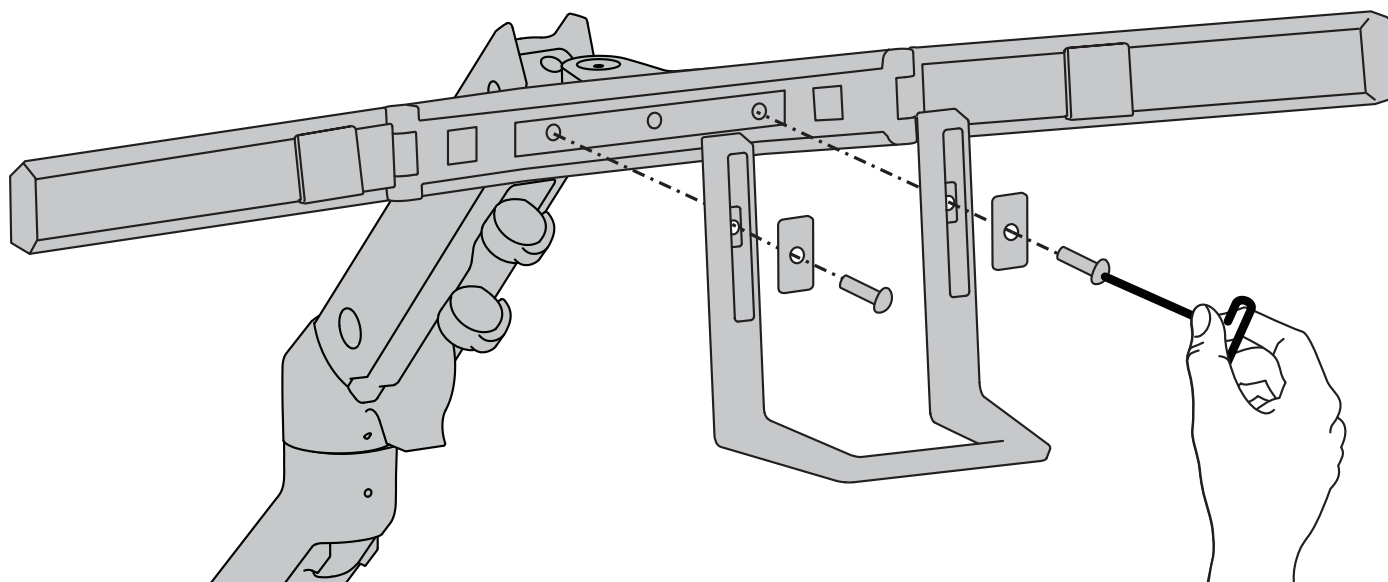
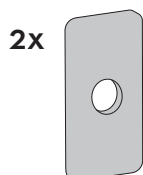
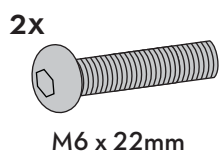

5 Plaats stang waterpas
Livellare la traversa
Bağlama Çubuğunu Dengeleyin
拉平横杆

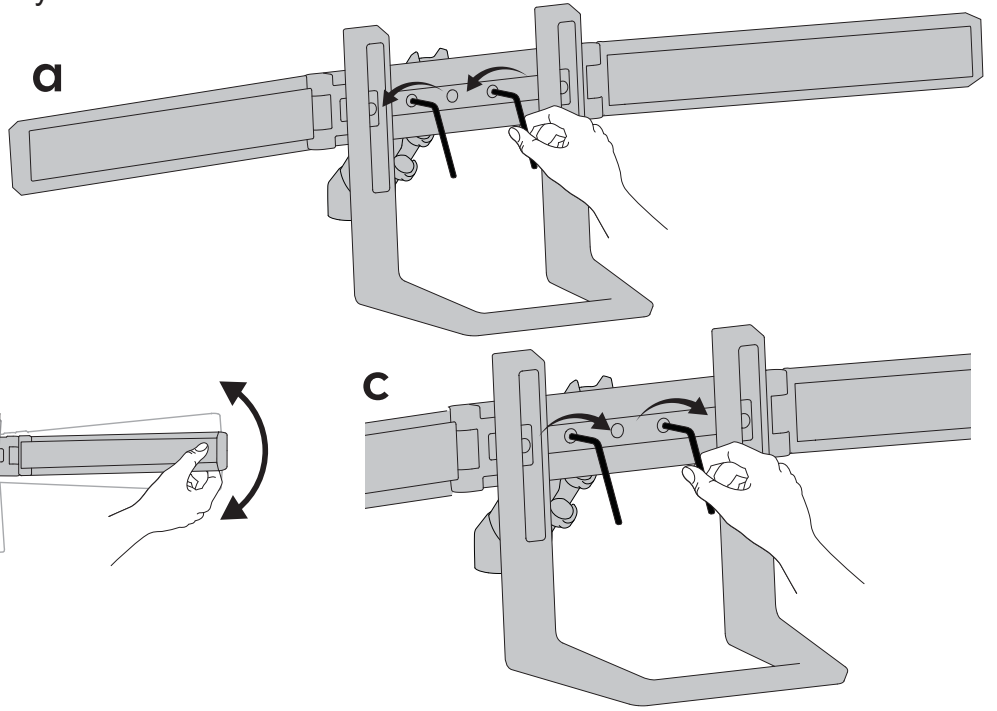
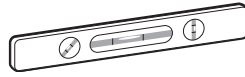

6

OPTIE: monteer stopschroef om rotatie van de monitor in staande/liggende stand te vergrendelen.
FACOLTATIVO: inserire la vite di arresto per bloccare la rotazione verticale/orizzontale del monitor.

İSTEĞE BAĞLI: Portre/peyzaj monitör dönüşünü kilitlemek için durdurma vidasını yerleştirin.

可选操作：嵌入止动螺丝锁定显示器的纵向/横向旋转。

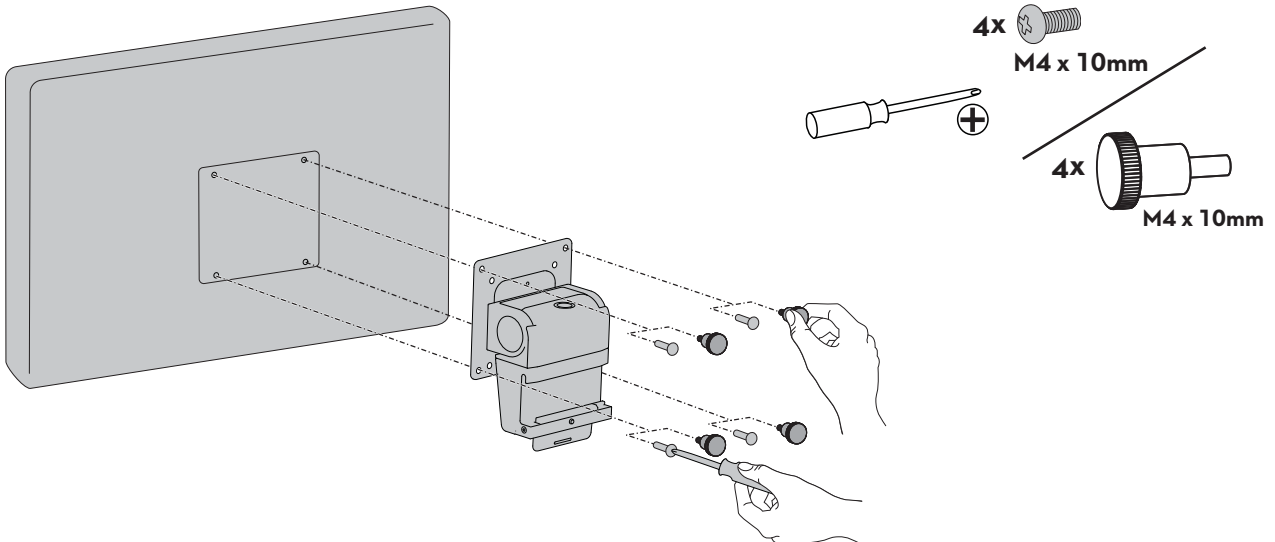
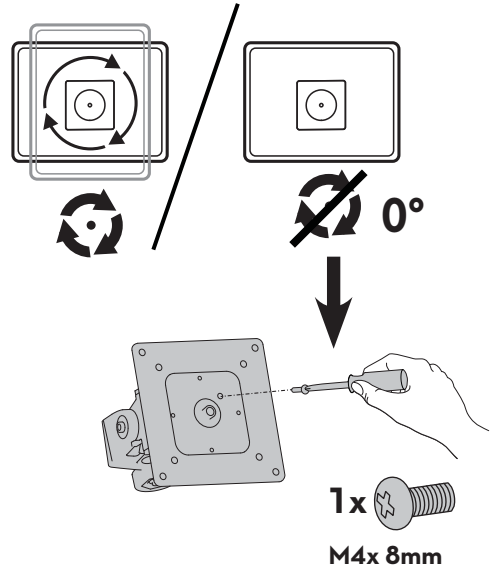

- 7** Bevestig monitors aan stang.
 Applicare i monitor alla traversa.
 Monitörleri bağlama çubuğuna yerleştirin.
 将显示器固定至横门上。

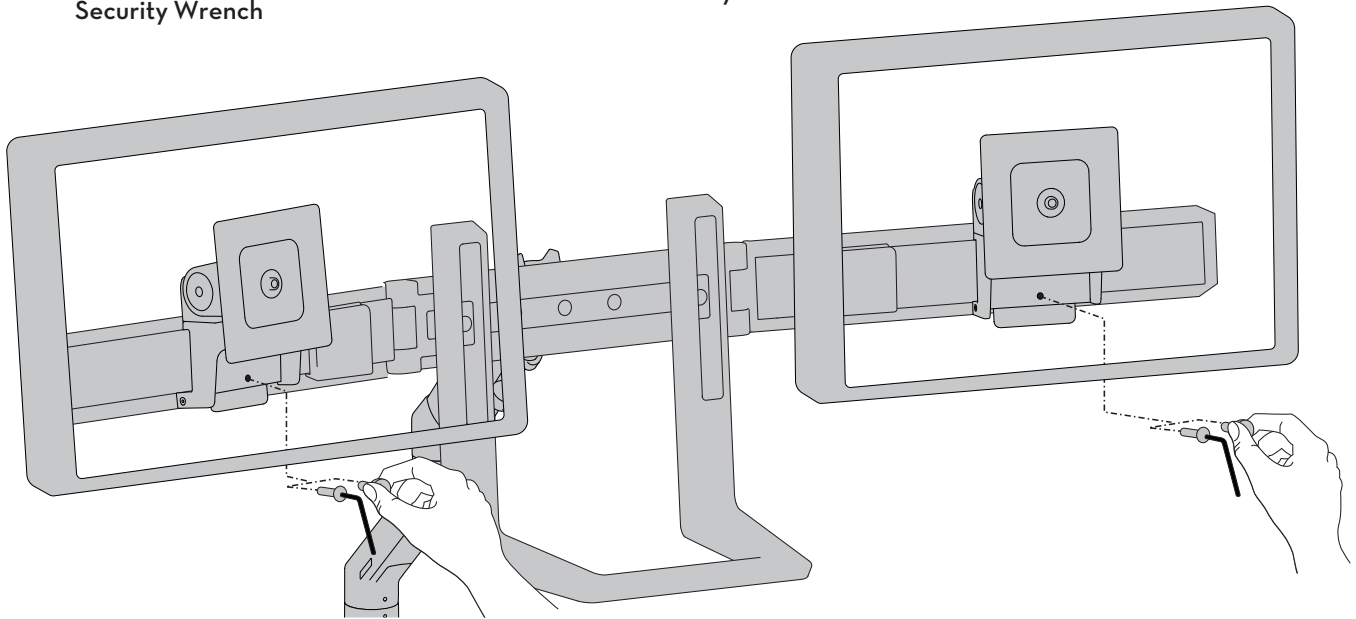
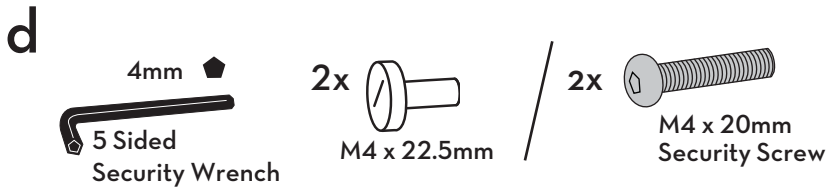
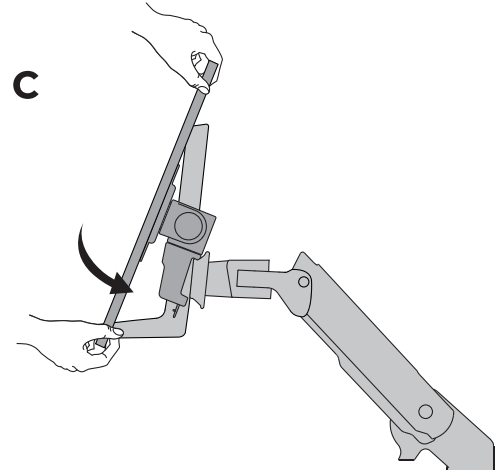
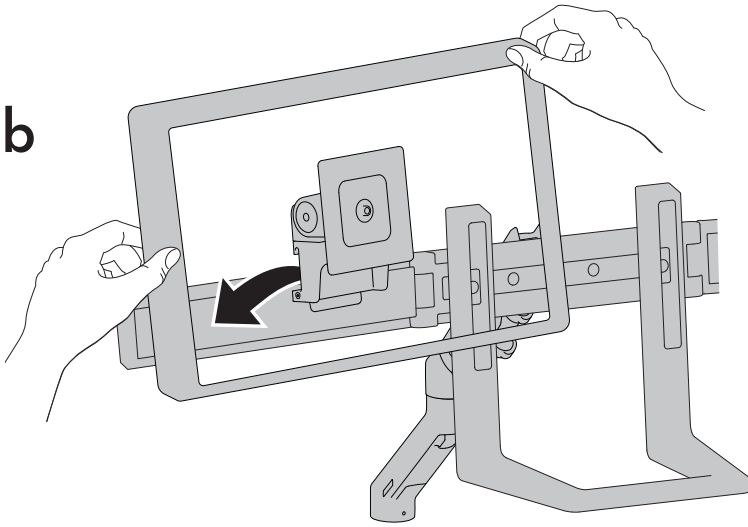
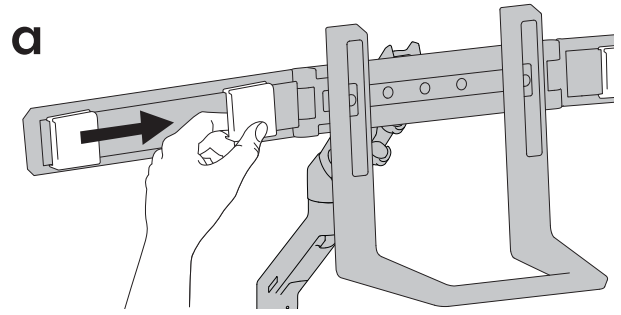

VOORZICHTIG: monitors zijn niet stabiel zolang ze niet volledig vastgezet zijn op de stang. Als de schroeven niet helemaal vastgezet worden, kan dit tot schade leiden aan de apparatuur.



ATTENZIONE: i monitor non sono stabili se non vengono fissati integralmente alla traversa. Se non si stringono completamente le viti, si potrebbero verificare infortuni o danni alle apparecchiature.



DİKKAT: Monitörler, bağlama çubuğuna sabitleninceye kadar sabit durmazlar. Vidaların sonuna kadar sıkılmaması donanımda hasara sebebiyet verebilir.



小心: 在完全固定在横门上之前, 显示器仍处于不稳固状态。如果未能完全拧紧螺丝, 可能会导致设备损坏。

8

2x



2x

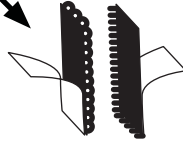

a

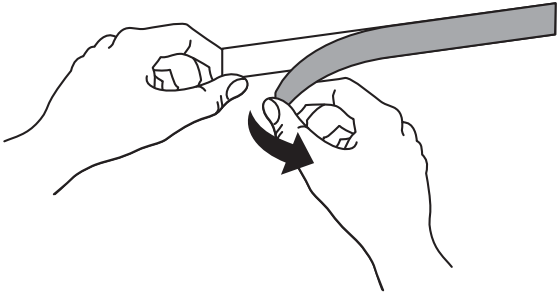

a

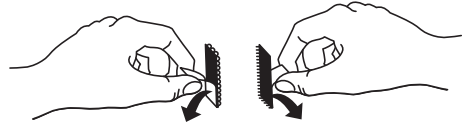

b

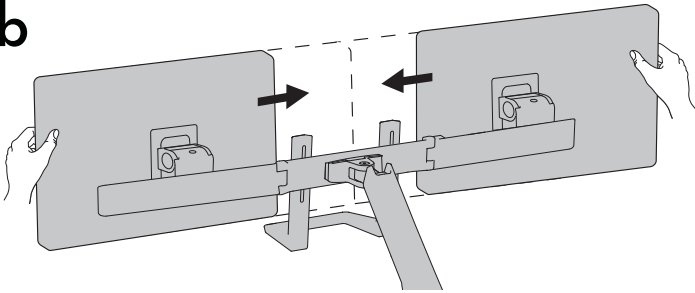

b

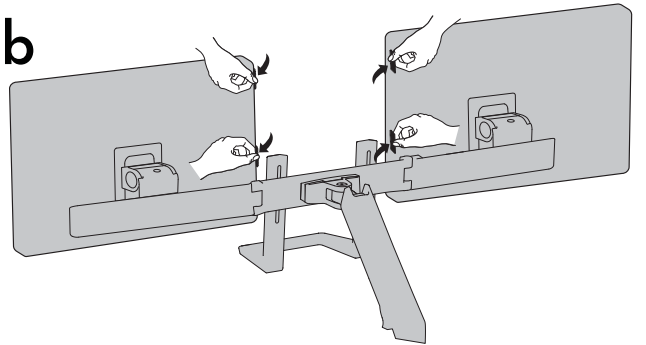

c

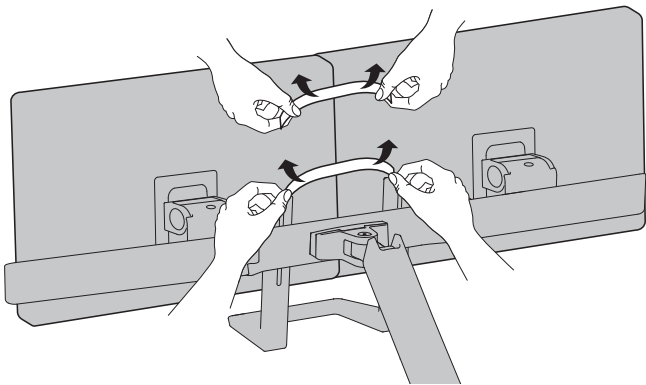

c

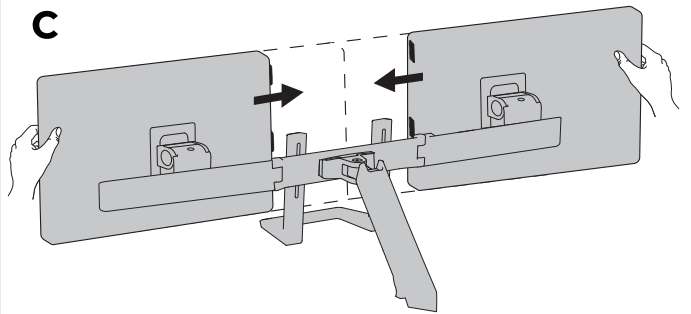

Hoe maak je de monitoren los van de dwarsbalk
Modalità per togliere i monitor dalla traversa
Monitörün bağlama çubuğundan sökülmesi.
如何从横杆上取下显示器

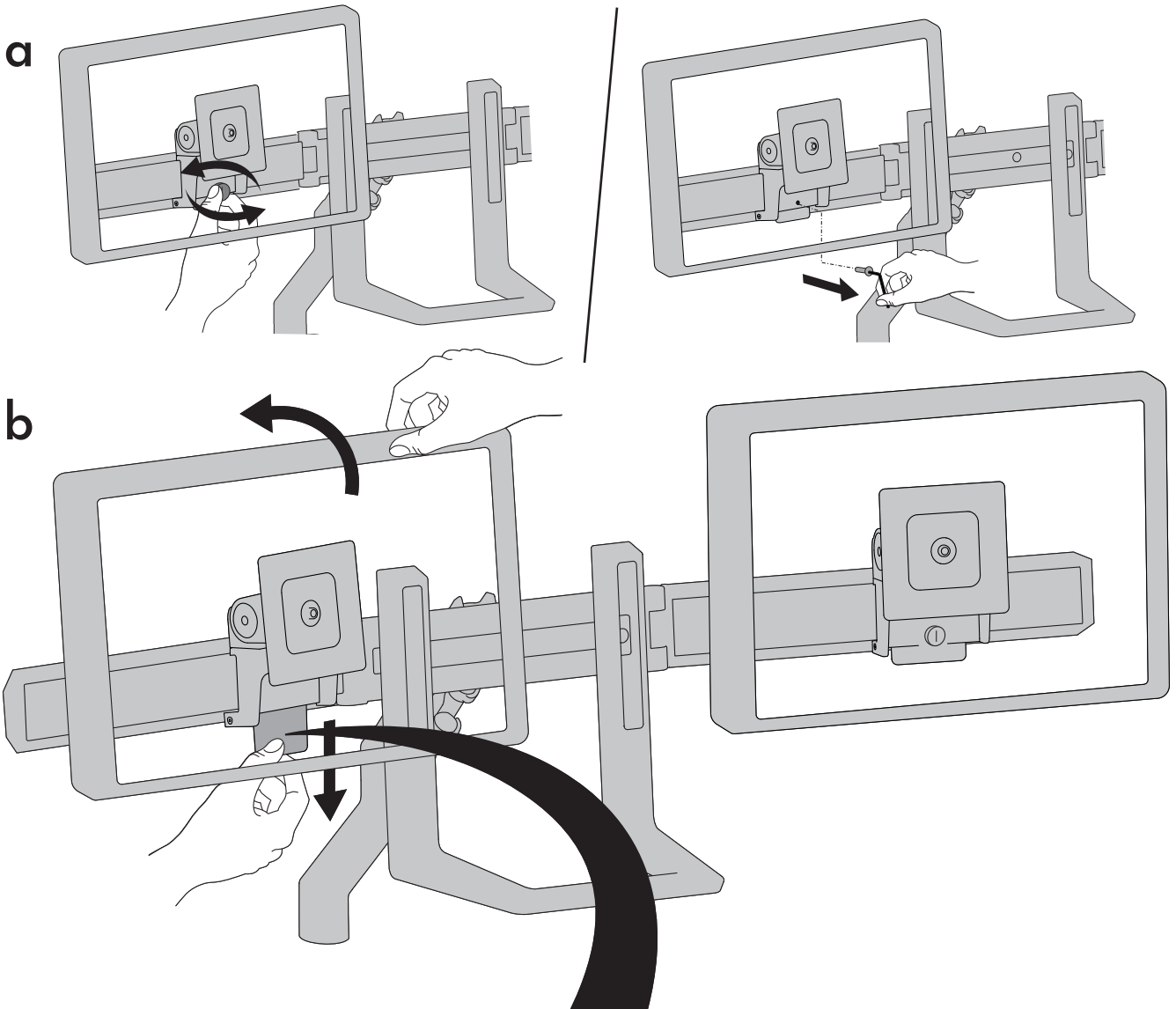

i trek omlaag
tirare verso il basso
geri çekin
向下拉动

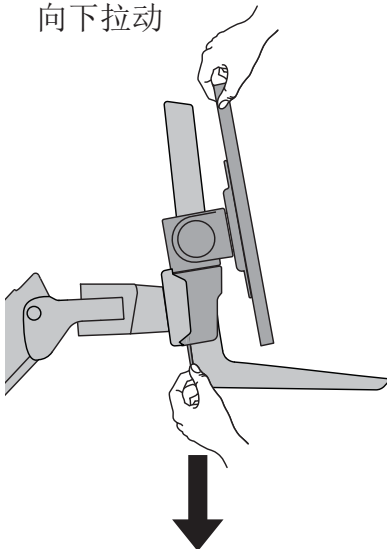

ii kantel
inclinare
eğın
倾斜

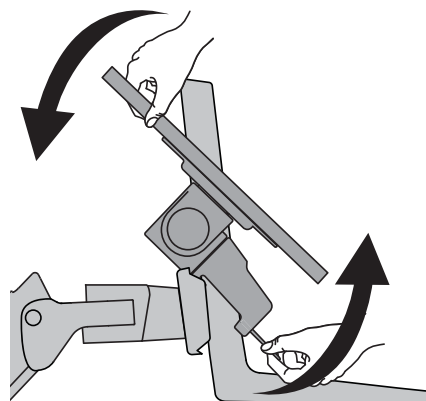

iii verwijder
togliere
çıkarmın
拉下

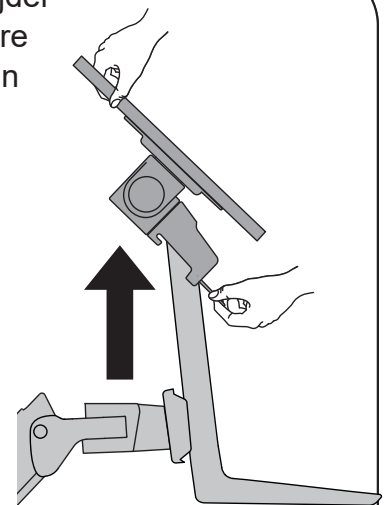

9



LET OP: Laat voldoende speling in de kabel om volledige bewegingsbereik mogelijk te maken.



Voorzichtig: Om te voorkomen dat de snoeren mogelijk beklemd raken, dient u de instructies voor het leiden van de snoeren in dit handboek te volgen. Nalaten deze instructies te volgen kan de apparatuur beschadigen of persoonlijk letsel veroorzaken.



NOTA: Lasciare sufficiente gioco per consentire al cavo l'intero intervallo di movimento.



Attenzione: Per evitare la possibilità di schiacciare i cavi, è importante seguire le istruzioni di instradamento dei cavi riportate nel presente manuale. La mancata osservanza delle presenti istruzioni può causare danni alle cose o infortuni personali.



NOT: Tam bir hareket olanağı sağlamak için kabloyu yeterince gevşek bırakın.



Dikkat: Kablolarda sıkışma olasılığını önlemek için bu el kitabındaki kablo yönlendirme talimatlarına uymak önemlidir. Bu talimatlara uyulmaması donanımda hasar ve/veya kişisel yaralanmayla sonuçlanabilir!



注：保持线缆有足够的松弛度以便全方位移动。



小心：为了避免夹住线缆，请务必遵守本手册中的布线说明。不遵守本警告指示可能导致设备损坏或人身伤害。

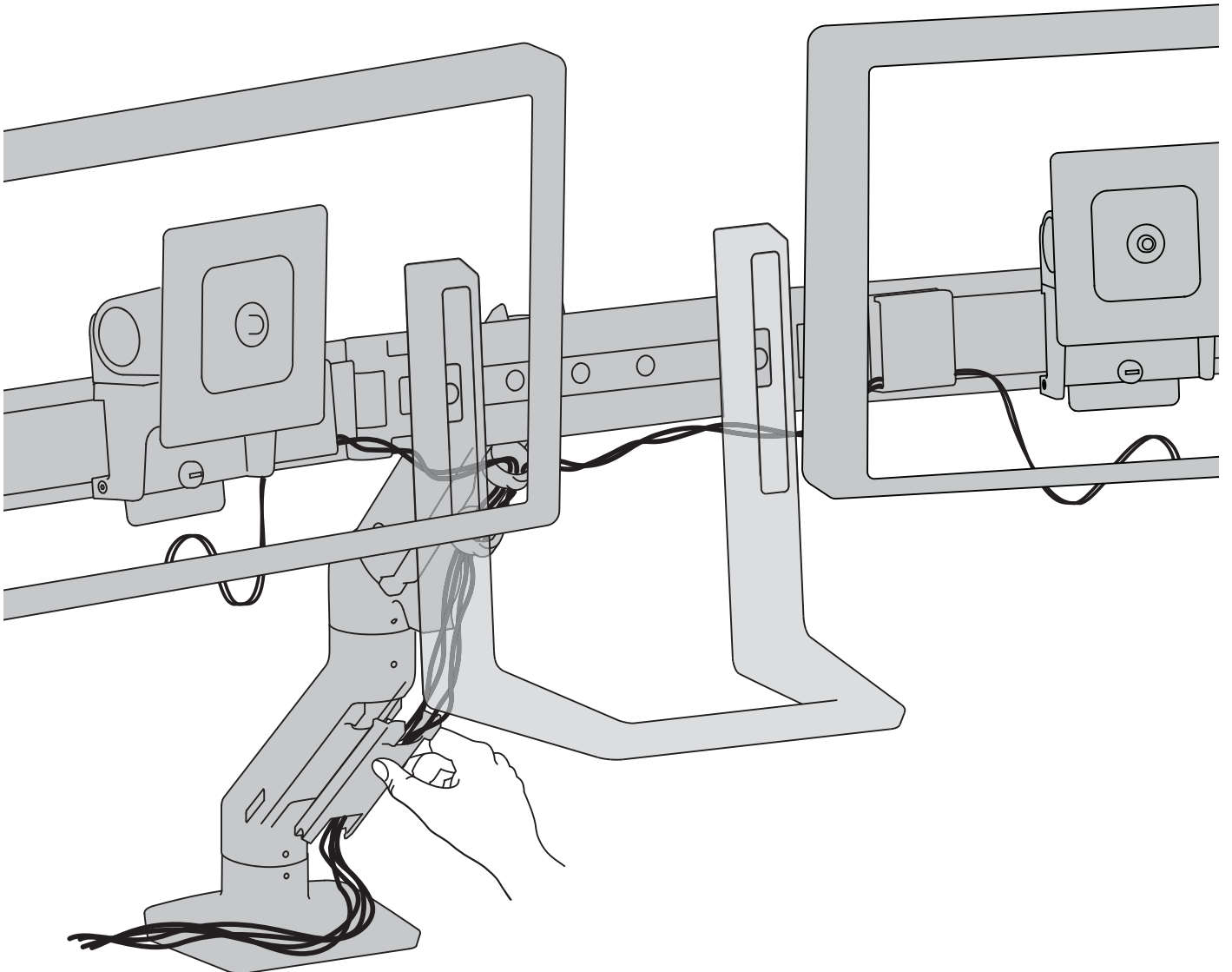



Belangrijk! U moet dit product bijstellen nadat de installatie voltooid is. Overtuig u ervan dat al uw apparatuur op de juiste wijze geïnstalleerd is op het product voordat u probeert bijstellingen uit te voeren. Dit product moet soepel en makkelijk bewegen door alle bewegingen en blijven staan waar u het zet. Als het te makkelijk of moeilijk beweegt of als het product niet in de gewenste posities blijft staan, volg dan de instructies voor het bijstellen om te zorgen voor soepele en makkelijke bewegingen. Afhankelijk van uw product en de bijstelling moet u mogelijk veel aan de schroeven en knoppen draaien om een verschil te merken. Elke keer als apparatuur toegevoegd of verwijderd wordt van dit product met als resultaat een verandering in het gewicht van de gemonteerde belasting, moet u deze stappen voor bijstelling opnieuw doorlopen om te zorgen voor een veilige en beste werking.

Importante! Al termine dell'installazione, sarà necessario regolare questo prodotto. Verificare che tutte le apparecchiature siano correttamente installate sul prodotto, prima di cercare di eseguire le regolazioni. Questo prodotto deve spostarsi in modo uniforme e scorrevole attraverso l'intero raggio di movimento, nonché restare fermo nel punto in cui viene collocato. Se gli spostamenti appaiono troppo agevoli o troppo difficoltosi, oppure se il prodotto non resta nelle posizioni previste, attenersi alle istruzioni sulla regolazione per ottenere spostamenti uniformi e scorrevoli. In base al prodotto e alla regolazione, è possibile che siano necessari molti giri per notare la differenza. Ogni volta che si aggiungono o tolgono apparecchiature dal prodotto, determinando una modifica nel peso del carico montato, occorre ripetere questi passaggi di regolazione, per garantire un funzionamento sicuro e ottimale.

Önemli! Montaj tamamlandıktan sonra bu ürün ayarlamamız gerekecektir. Ayarlamalar yapmadan önce tüm donanımınızın ürün üzerine düzgün şekilde monte edildiğinden emin olun. Bu ürün tüm hareket alanı boyunca düzgünce ve kolayca hareket etmeli ve ayarladığınız yerde kalmalıdır. Eğer hareketler çok kolay veya çok zorsa ya da ürün istenen konumlarda durmuyorsa, düzgün ve kolay hareketler oluşturmak için ayar talimatlarını izleyin. Ürünüze ve ayara bağlı olarak bir farkın tespiti için birçok dönüş gerekebilir. Monte edilen yükün ağırlığında bir değişikliğe yol açacak bir donanımı bu ürün üzerine eklediğiniz veya çıkardığınız zaman güvenli ve en uygun çalışmayı sağlamak üzere bu ayar adımlarını tekrarlamalısınız.

重要说明! 本产品安装完成后需要调节。在尝试进行调节之前, 确保所有设备都正确安装在产品上。本产品应能在整个动作范围内灵活自如地移动, 并能固定在所设定的位置。如果移动过于容易或过于困难, 或者产品不能固定在想要的位置上, 请按照调节说明操作, 使动作灵活自如。根据您所用产品及调节方式, 可能需要旋转几圈后才能注意到差别。每次添加或者从本产品上拆除设备时, 都会使安装负荷重量发生变化, 您应该重复调节步骤, 确保运行状态安全、最佳。

a

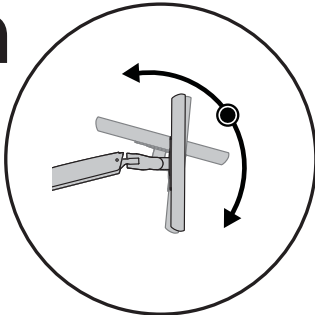

Kantel - Naar voren en naar achteren Inclinazione - Avanti ed Indietro Eğın - Öne ve Geriye 倾斜 - 前后

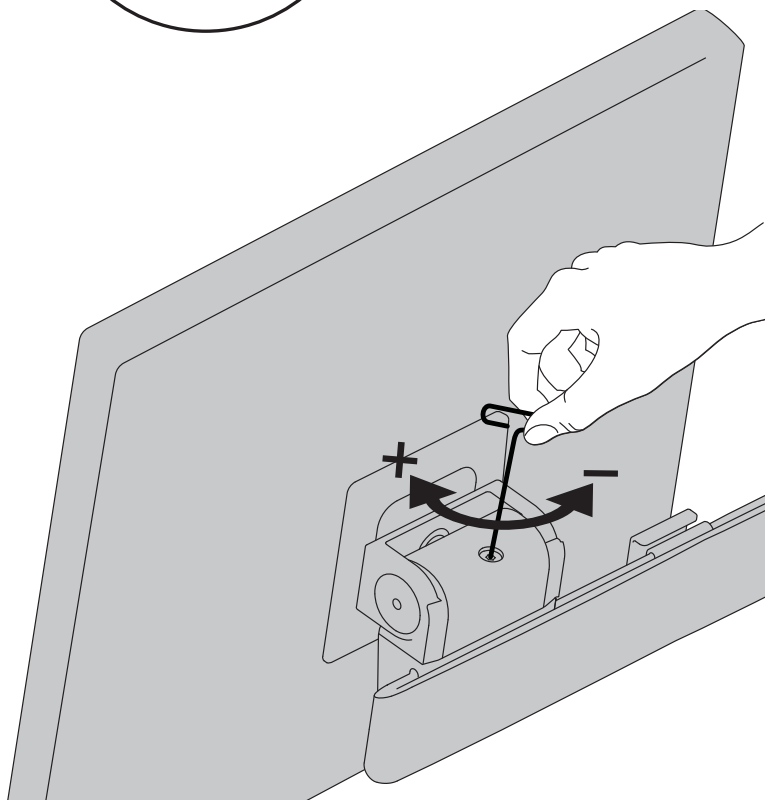

De tilsterkte verhogen
Als het geïnstalleerde gewicht te zwaar is of als dit product niet omhoog blijft staan als het omhoog getild is, moet u de tilsterkte verhogen.

Aumentare la potenza di sollevamento
Se il carico montato è eccessivo o se questo prodotto non rimane su dopo essere stato sollevato, occorre aumentare la potenza di sollevamento.

Kaldırma Gücünü Artırın
Monte edilen ağırlık çok fazlaysa veya bu ürün yükseltildiği zaman yukarıda durmuyorsa, bu durumda Kaldırma Gücünü artırmanız gerekecektir:

增大升力
如果安装重量过重, 或者升起本产品时, 产品不停留在升起位置, 那么您需要增大升力:



De tilsterkte verlagen
Als het geïnstalleerde gewicht te licht is of als dit product niet omlaag blijft staan als het naar beneden geduwd is, moet u de tilsterkte verlagen.

Diminuire la potenza di sollevamento
Se il carico montato è troppo leggero o se questo prodotto non rimane giù dopo essere stato abbassato, occorre ridurre la potenza di sollevamento.

Kaldırma Gücünü Azaltın
Monte edilen ağırlık çok azsa veya bu ürün alçaltıldığı zaman aşağıda durmuyorsa, bu durumda Kaldırma Gücünü azaltmanız gerekecektir:

减小升力
如果安装重量过轻, 或者降下本产品时, 产品不停留在降下位置, 那么您需要减小升力:

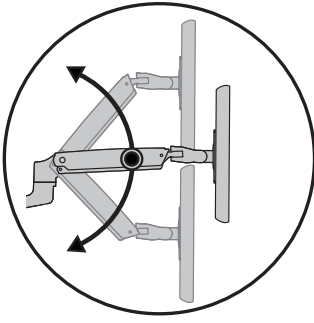
b

Verstel in hoogte - Omhoog en omlaag
Sollevamento - Su e Giù
Kaldırın - Yukarı ve aşağı
升降 (上下)

1 Zet arm op de hoogste stand.

Sollevare il braccio fino al punto più elevato.

Kolu en yüksek konuma getirin

将支臂抬升至最高位。

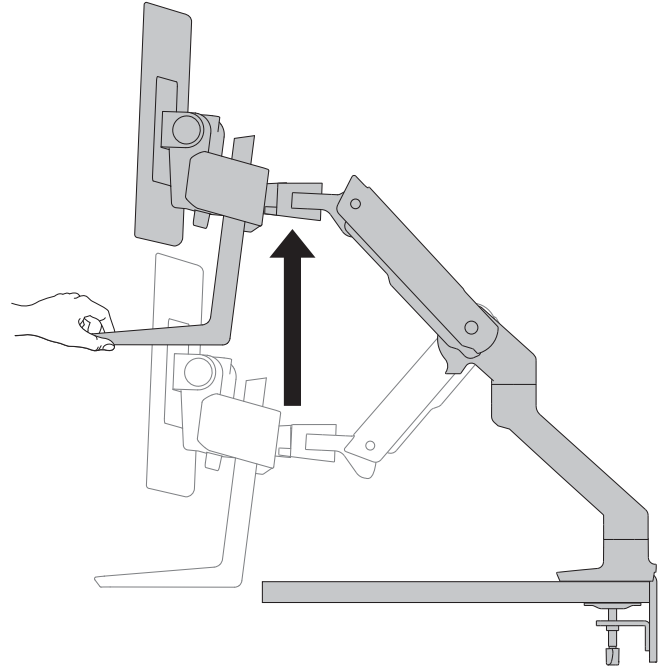
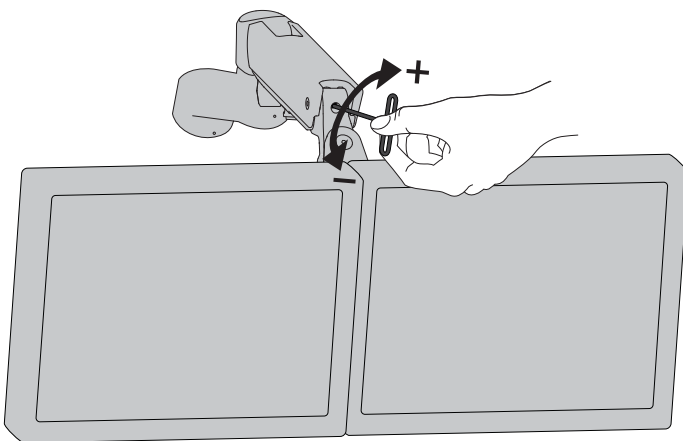
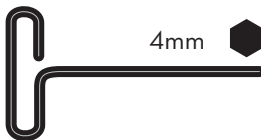
**2**

De tilsterkte verhogen
 Als het geïnstalleerde gewicht te zwaar is of als dit product niet omhoog blijft staan als het omhoog getild is, moet u de tilsterkte verhogen.

Aumentare la potenza di sollevamento
 Se il carico montato è eccessivo o se questo prodotto non rimane su dopo essere stato sollevato, occorre aumentare la potenza di sollevamento.

Kaldırma Gücünü Artırın
 Monte edilen ağırlık çok fazlaysa veya bu ürün yükseltildiği zaman yukarıda durmuyorsa, bu durumda Kaldırma Gücünü artırmanız gerekecektir.

增大升力
 如果安装重量过重，或者升起本产品时，产品不停留在升起位置，那么您需要增大升力：



De tilsterkte verlagen
 Als het geïnstalleerde gewicht te licht is of als dit product niet omlaag blijft staan als het naar beneden geduwd is, moet u de tilsterkte verlagen.

Diminuire la potenza di sollevamento
 Se il carico montato è troppo leggero o se questo prodotto non rimane giù dopo essere stato abbassato, occorre ridurre la potenza di sollevamento.

Kaldırma Gücünü Azaltın
 Monte edilen ağırlık çok azsa veya bu ürün alçaltıldığı zaman aşağıda durmuyorsa, bu durumda Kaldırma Gücünü azaltmanız gerekecektir.

减小升力
 如果安装重量过轻，或者降下本产品时，产品不停留在降下位置，那么您需要减小升力：

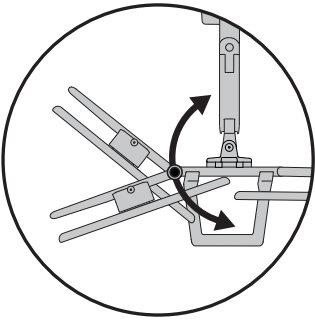
C

Aanpassing scharnier van stang Regolazione della cerniera della traversa Bağlama Çubuğu Menteşe Ayarı 调整横门铰链

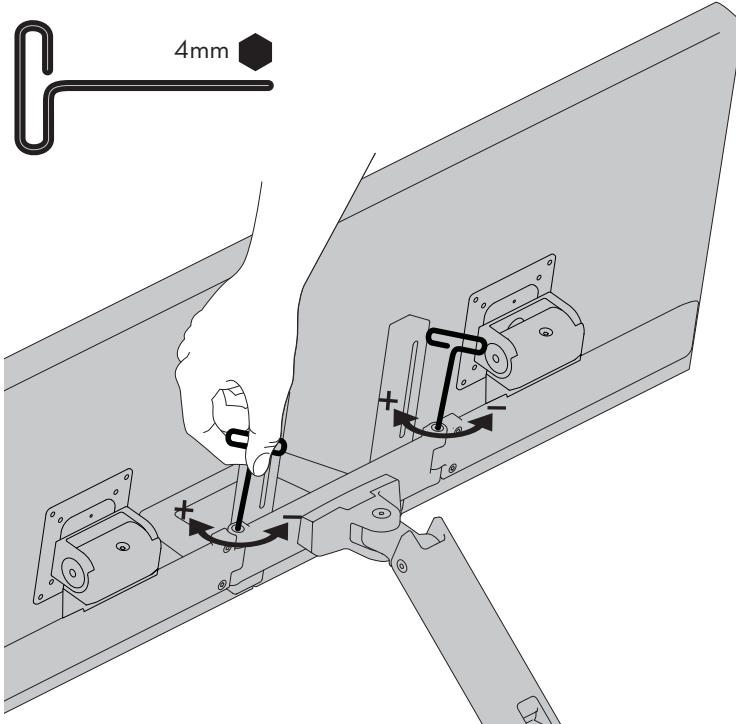

Wrijving verhogen
Als dit product te makkelijk heen en weer beweegt, moet u de wrijving verhogen:

Aumentare l'attrito
Se il prodotto si sposta troppo facilmente, occorrerà aumentare l'attrito:

Sürtünmeyi Artırın
Eğer bu ürün çok kolay hareket ediyorsa bu durumda sürtünmeyi artırmamız gerekecektir:

增加摩擦力
如果该产品太易于移动，那么您将需要增加摩擦力：

Wrijving verlagen
Als dit product te moeilijk heen en weer beweegt, moet u de wrijving verlagen:

Ridurre l'attrito
Se il prodotto si sposta con troppa difficoltà, occorrerà ridurre l'attrito:

Sürtünmeyi Azaltın
Eğer bu ürün çok zor hareket ediyorsa bu durumda sürtünmeyi azaltmamız gerekecektir:

減少摩擦力
如果该产品太难于移动，那么您将需要降低摩擦力：

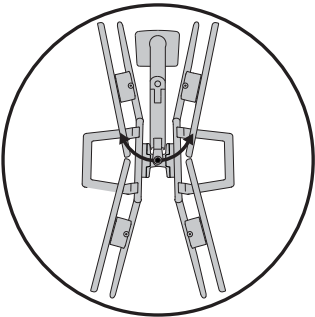
d

Aanpassen van de hoek van de dwarsstang Regolazione della rotazione (Pan) della traversa Bağlama Çubuğu Tava Ayarı 横门横向调节

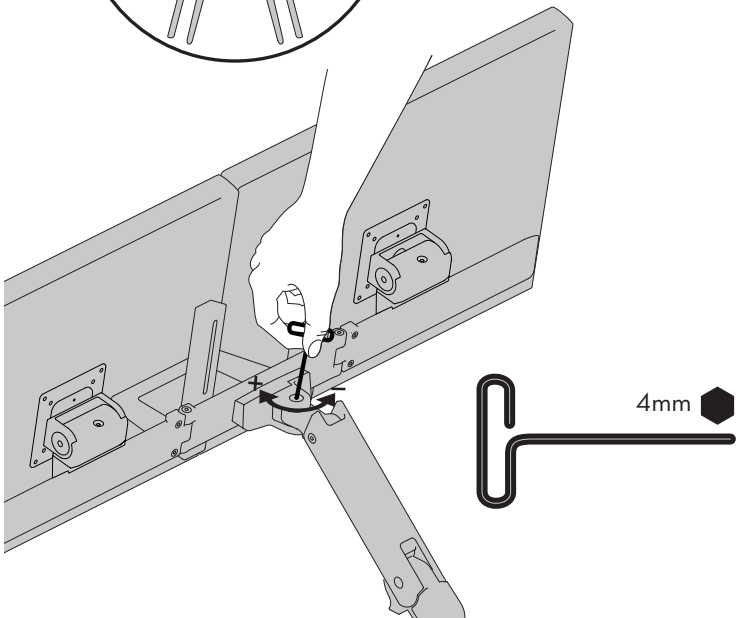

Wrijving verhogen
Als dit product te makkelijk heen en weer beweegt, moet u de wrijving verhogen:

Aumentare l'attrito
Se il prodotto si sposta troppo facilmente, occorrerà aumentare l'attrito:

Sürtünmeyi Artırın
Eğer bu ürün çok kolay hareket ediyorsa bu durumda sürtünmeyi artırmamız gerekecektir:

增加摩擦力
如果该产品太易于移动，那么您将需要增加摩擦力：

Wrijving verlagen
Als dit product te moeilijk heen en weer beweegt, moet u de wrijving verlagen:

Ridurre l'attrito
Se il prodotto si sposta con troppa difficoltà, occorrerà ridurre l'attrito:

Sürtünmeyi Azaltın
Eğer bu ürün çok zor hareket ediyorsa bu durumda sürtünmeyi azaltmamız gerekecektir:

減少摩擦力
如果该产品太难于移动，那么您将需要降低摩擦力：

e

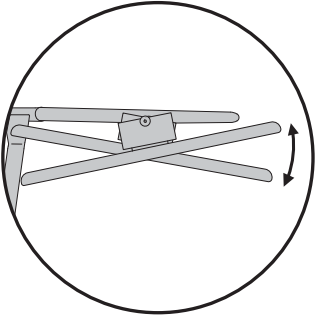

Aanpassen van de hoek van het beeldscherm
Regolazione della rotazione (Pan) del monitor
Monitör Tavası - Sol ve Sağ
监视器横向调节

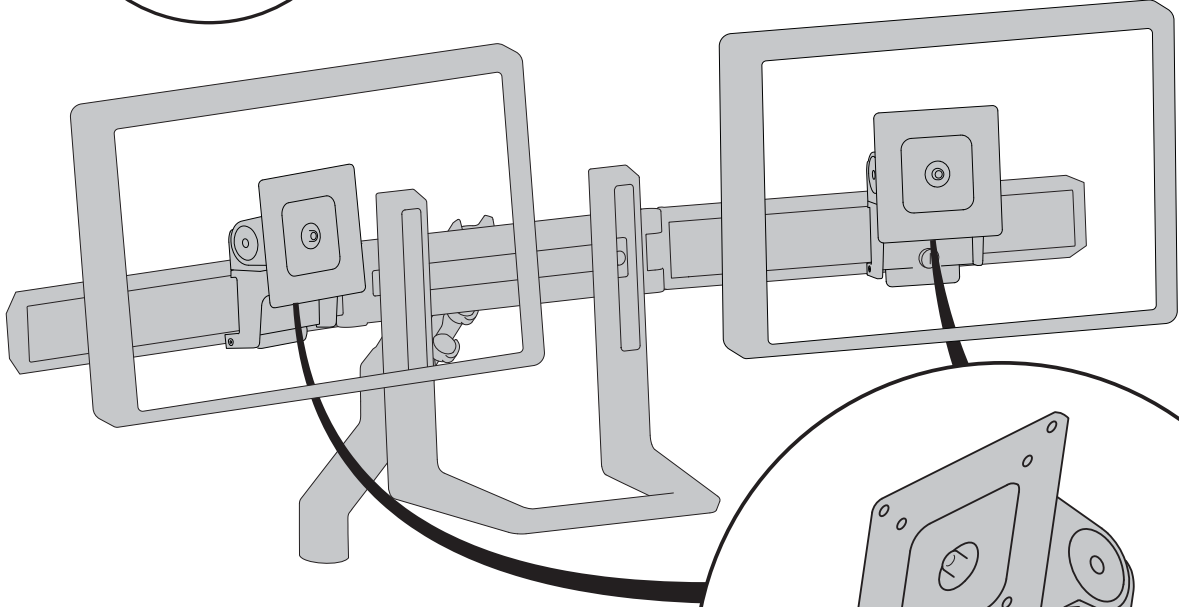

Wrijving verhogen

Als dit product te makkelijk heen en weer beweegt, moet u de wrijving verhogen:

Aumentare l'attrito

Se il prodotto si sposta troppo facilmente, occorrerà aumentare l'attrito:

Sürtünmeyi Artırın

Eğer bu ürün çok kolay hareket ediyorsa bu durumda sürtünmeyi artırmanız gerekecektir:

增加摩擦力

如果该产品太易于移动，那么您将需要增加摩擦力：

Wrijving verlagen

Als dit product te moeilijk heen en weer beweegt, moet u de wrijving verlagen:

Ridurre l'attrito

Se il prodotto si sposta con troppa difficoltà, occorrerà ridurre l'attrito:

Sürtünmeyi Azaltın

Eğer bu ürün çok zor hareket ediyorsa bu durumda sürtünmeyi azaltmanız gerekecektir:

减少摩擦力

如果该产品太难于移动，那么您将需要降低摩擦力：

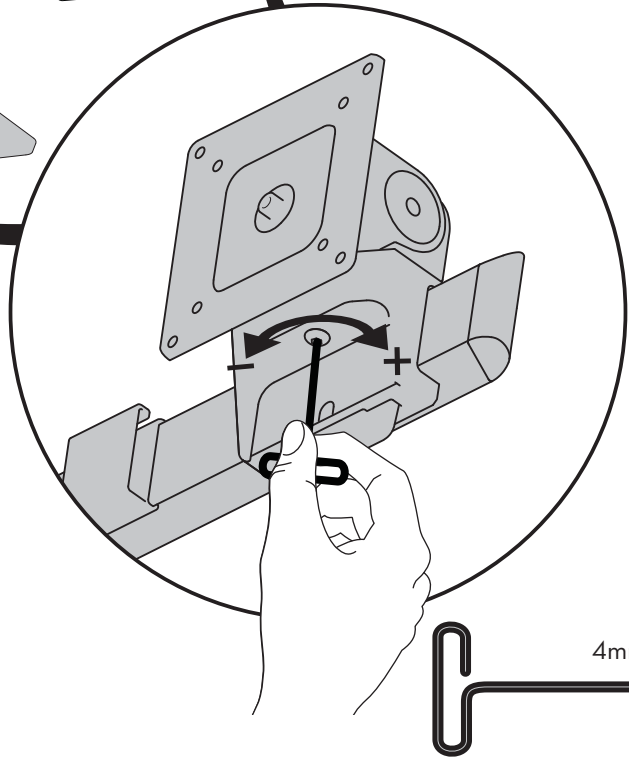

4mm

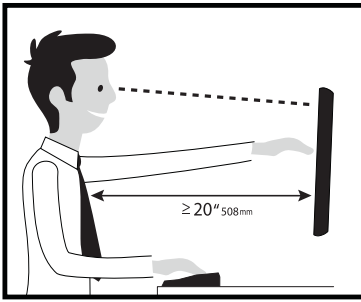

Ready to get moving on an active workstyle? Check out www.ergotron.com/tips to get started.

Learn more about ergonomic computer use at: www.ergotron.com/ergonomics

NL De nieuwste Gids voor installatie door de gebruiker kunt u vinden op: www.ergotron.com
 Ga voor garantie naar: www.ergotron.com/warranty
 Ga voor service naar: www.ergotron.com
 Plaatselijke telefoonnummers voor de klantendienst kunt u vinden op: <http://contact.ergotron.com>

IT Per la versione più recente della Guida all'installazione per l'utente, visitare il sito web: www.ergotron.com
 Per la garanzia visitare: www.ergotron.com/warranty
 Per assistenza visitare: www.ergotron.com
 Per conoscere i numeri di telefono dell'assistenza clienti locale, visitare: <http://contact.ergotron.com>

TR En yeni Kullanım Kılavuzu sürümü için lütfen www.ergotron.com adresini ziyaret ediniz.
 Garanti için www.ergotron.com/warranty adresini ziyaret edin
 Servis için www.ergotron.com adresini ziyaret edin
 Yerel müşteri destek telefon numaraları için <http://contact.ergotron.com> adresini ziyaret edin

ZH 若需最新的用户安装指南，请访问：www.ergotron.com
 为保证参观：www.ergotron.com/warranty
 对于上门服务：www.ergotron.com
 若需当地客户服务电话号码，请访问：<http://contact.ergotron.com>

NL LET OP: Als u contact opneemt met de klantenservice, geef dan het serienummer door.

IT NOTA: In occasione di contatti con l'assistenza clienti, indicare il numero di serie.

TR OBS! När du kontaktar kundtjänst, hänvisa till serienumret.

ZH 注：联系客服时，请提供序列号。

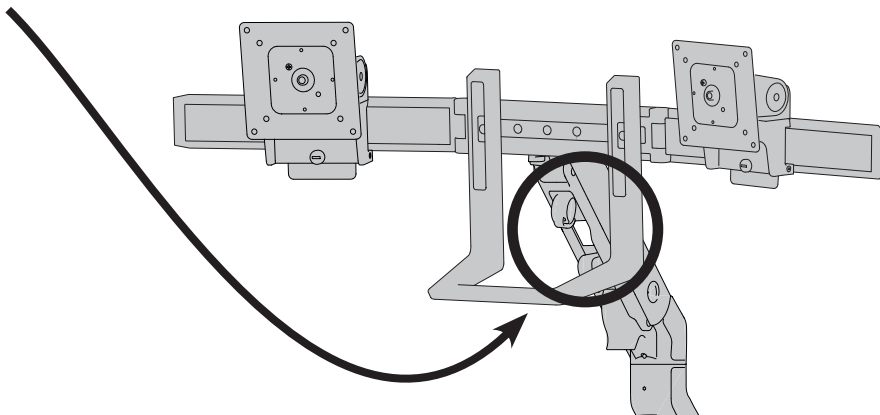

ergotron®

www.ergotron.com | USA: 1-800-888-8458 | Europe: +31 (0)33-45 45 600 | China: 400-120-3051 | Japan: japansupport@ergotron.com

© 2016 Ergotron, Inc. All rights reserved.

While Ergotron, Inc. makes every effort to provide accurate and complete information on the installation and use of its products, it will not be held liable for any editorial errors or omissions (including those made in the process of translation from English to another language), or for incidental, special or consequential damages of any nature resulting from furnishing this instruction and performance of equipment in connection with this instruction. Ergotron, Inc. reserves the right to make changes in the product design and/or product documentation without notification to its users. For the most current product information, or to know if this document is available in languages other than those herein, please contact Ergotron. No part of this publication may be reproduced, stored in a retrieval system, or transmitted in any form or by any means, electronic, mechanical, photocopying, recording or otherwise without the prior written consent of Ergotron, Inc., 1181 Trapp Road, Eagan, Minnesota, 55121, USA Patents Pending and Patented U.S. & Foreign. Ergotron is a registered trademark of Ergotron, Inc.