

ergotron®

Grommet Kit

Mounts Ergotron LX Arms to the WorkFit-T, TL & TLE
Sit-Stand Desktop Workstations

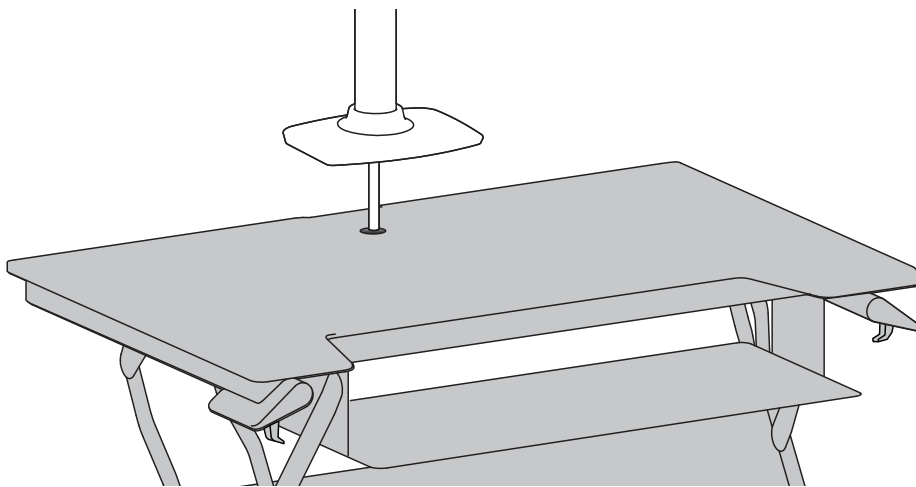

CAUTION! This Kit is only for the following Ergotron LX Arms:

Mounting products other than the ones listed will create an unstable situation and may result in equipment damage and/or personal injury.

45-241/45-490

LX Desk Mount LCD Monitor Arm

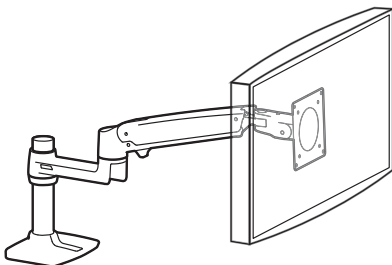

45-489

LX Desk Dual Direct Arm

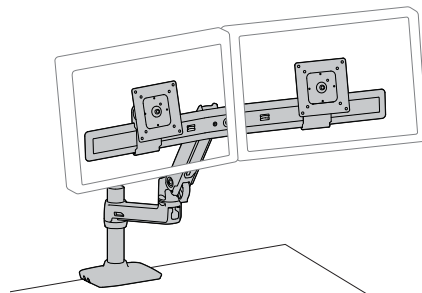

45-245/45-491

LX Dual Side-by-Side Arm

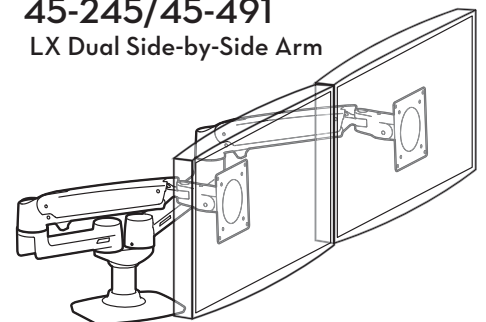

English



For the latest User Installation Guide please visit: www.ergotron.com

English, Español, Français, Deutsch, Nederlands, Italiano, Svenska, 日本語, 汉语

www.ergotron.com | USA: 1-800-888-8458 | Europe: +31 (0)33-45 45 600 | China: 400-120-3051 | Japan: japansupport@ergotron.com

Safety

! WARNING	 <small>828-100</small>
PINCH POINT DO NOT place hands on or near support bars. Pinch points are created during lifting and lowering the worksurface. Failure to follow these instructions may result in serious personal injury.	



Warning: Impact Hazard! Moving Parts can Crush and Cut.
Raise this product to its full up position before lifting off the desk.
Two people are required to lift this product off the desk.
Do not tip this product on its side or upside down. This product must remain upright at all times.
Failure to heed this warning may cause unintended motion of the lift mechanism resulting in possible serious personal injury and or property damage!



Warning: Impact Hazard! Worksurface under tension. Moving Parts can Crush and Cut.
Raise worksurface to top of vertical adjustment **BEFORE** removing equipment.
Failure to heed this warning may result in serious personal injury and or property damage!



Warning: Because mounting surface materials can vary widely, it is imperative that you make sure mounting surface is strong enough to handle mounted product and equipment.



CAUTION! Follow these instructions when drilling a new grommet hole. Failure to follow these instructions may cause damage to equipment or create an unstable situation resulting in a tipping hazard causing personal injury or equipment damage.

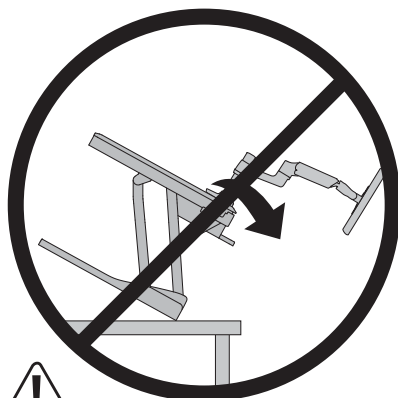

CAUTION! TIPPING HAZARD
Rotating display past **FRONT** or **REAR** edge may create an unstable situation and could result in equipment damage and/or personal injury.

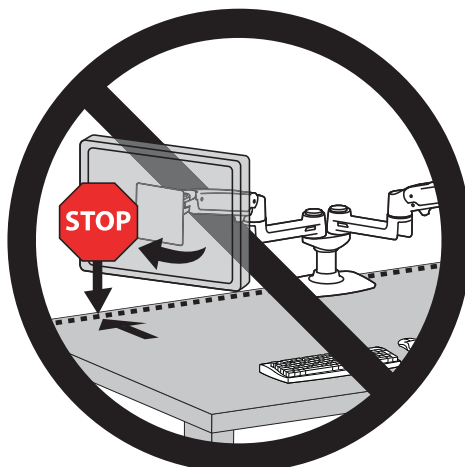

Safety

CAUTION: DO NOT EXCEED MAXIMUM LISTED WEIGHT CAPACITY. SERIOUS INJURY OR PROPERTY DAMAGE MAY OCCUR!

New Maximum Arm Weight Capacity when mounted on the WorkFit-T, TL, TLE

45-241/45-490
LX Desk Mount
LCD Monitor Arm

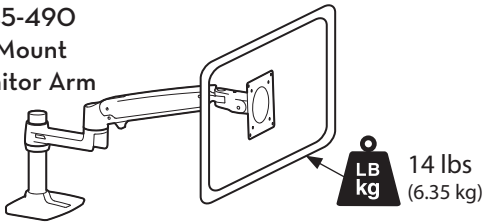

45-489
LX Desk Dual Direct Arm

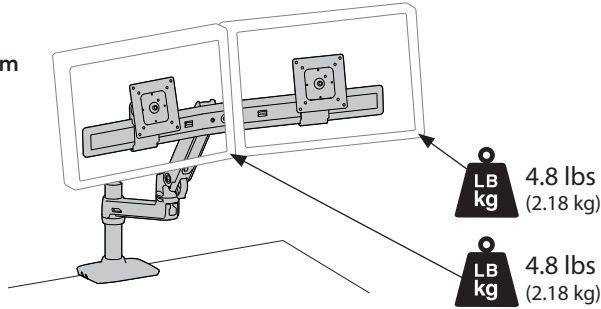

45-245/45-491
LX Dual Side-by-Side Arm

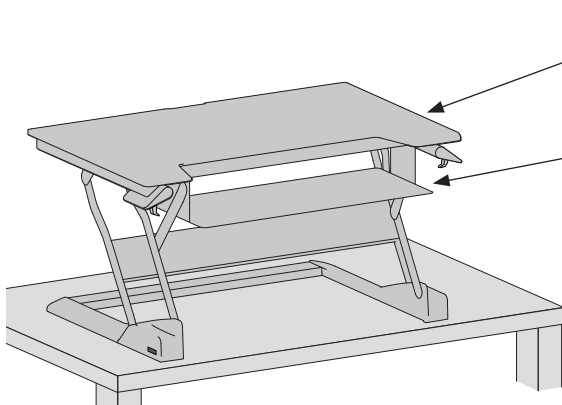
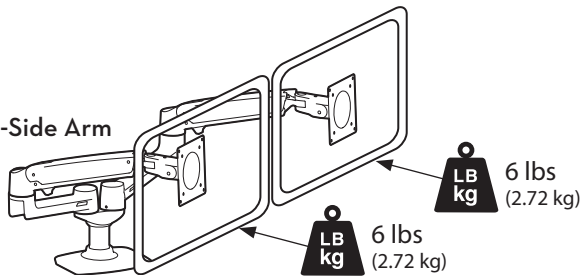

A **LB kg** **WORKFIT-T** 10 - 35 lbs* (4.5 - 15.88kg) / **A** **LB kg** **WORKFIT-TL, TLE** 10 - 40 lbs* (4.5 - 18.2kg)

B **LB kg** ≤ 5 lbs (2.27 kg)

LB kg **WorkFit-T: A+B= 10 - 35 lbs (4.5 - 15.88 kg)**
LB kg **WorkFit-TL, TLE: A+B= 10 - 40 lbs (4.5 - 18.2 kg)**

*** Include the weight of the Arm(s) and monitor(s) when calculating total mounted weight.**

45-241/45-490
LX Desk Mount
LCD Monitor Arm

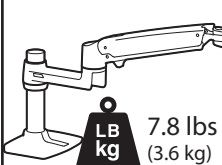

45-489
LX Desk Dual Direct Arm

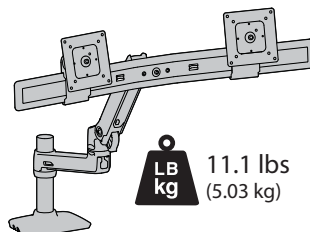

45-245/45-491
LX Dual Side-by-Side Arm

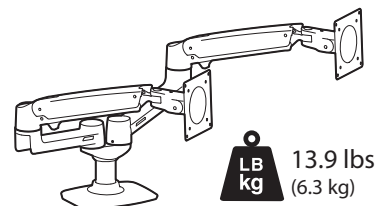



Components

	A	B	C
1	1x 	1x 	1x
2	1x 	1/4-20 1/4-20 x 1.4" 	1x
3	1x 		

Tools Needed

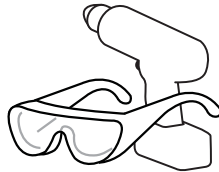
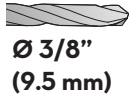
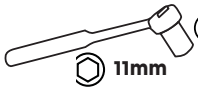

1 Lift to full up position.

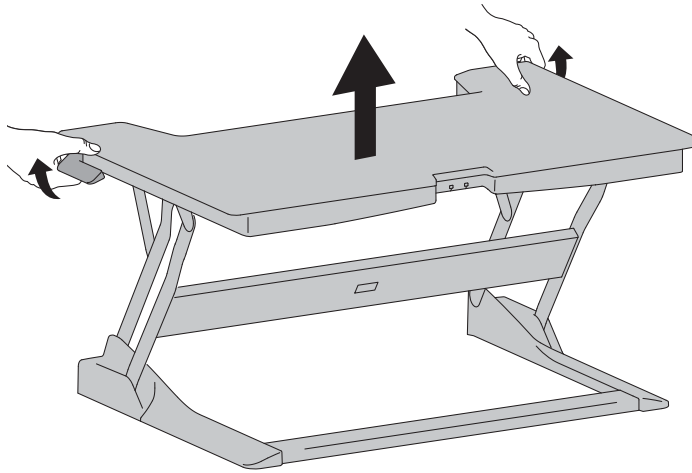

2

Use center existing grommet hole.

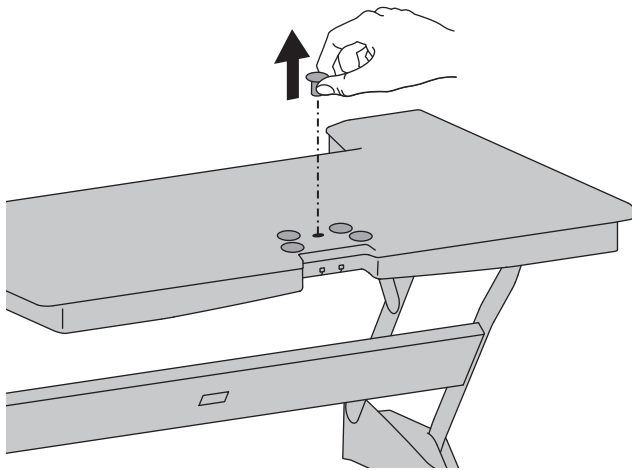

DO NOT use any other holes.



Drill a new grommet hole using the template.



CAUTION! Drilling a new grommet hole is only when mounting the 45-241 LX Desk Mount LCD Monitor Arm. Drilling a new grommet hole for any other product will create an unstable situation and may result in equipment damage and/or personal injury.

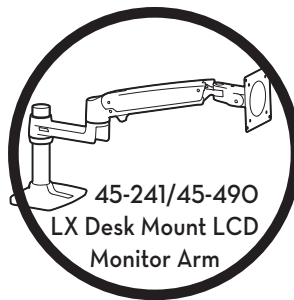

45-241/45-490
LX Desk Mount LCD
Monitor Arm

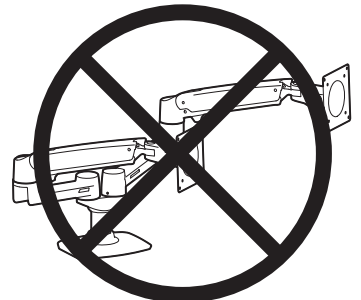

45-245/45-491
LX Dual Side-by-Side Arm

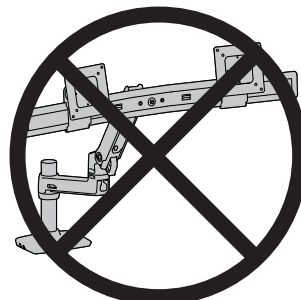

45-489
LX Desk Dual
Direct Arm



 **CAUTION!** Follow these instructions when drilling a new grommet hole. Failure to follow these instructions may cause damage to equipment or create an unstable situation resulting in a tipping hazard causing personal injury or equipment damage.

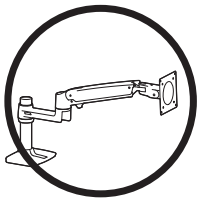

45-241
LX Desk Mount
LCD Monitor Arm

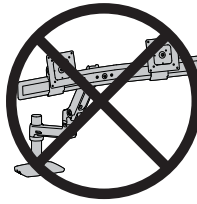

45-489
LX Desk Dual
Direct Arm

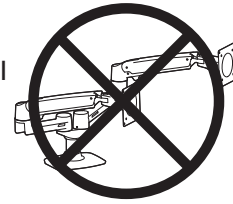

45-245
LX Dual
Side-by-Side Arm

Drill a new grommet hole using the template.

1. Make sure you use the correct side of the template for your work surface:
 - One side of the template is for the WorkFit-T which has a 35" (889) wide worksurface.
 - The other side of the template is for the WorkFit-TL and TLE which are wider and have a 37.5" (953 kg) wide worksurface.
2. Align the 2 holes in template with the front two plugs in the worksurface.
Make sure you use the correct side of the template for your work surface.
3. Drill your grommet hole anywhere within the white area of the template.
DO NOT drill in the shaded areas of the templates.

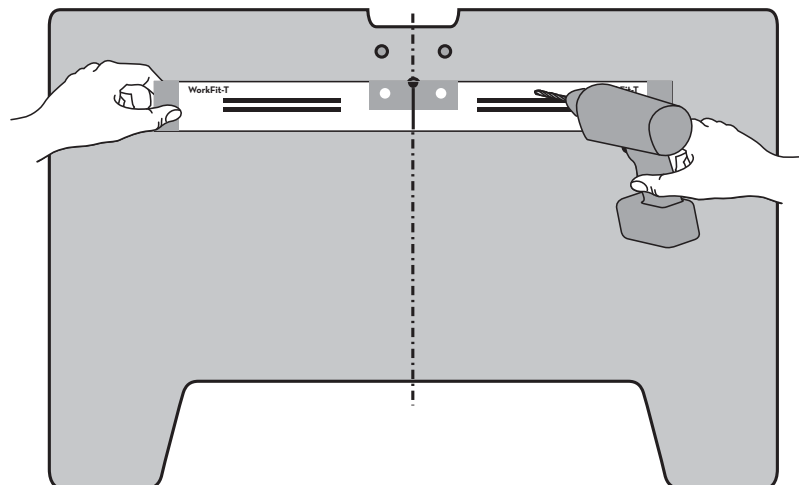
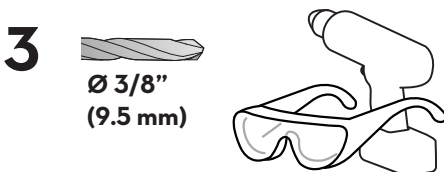
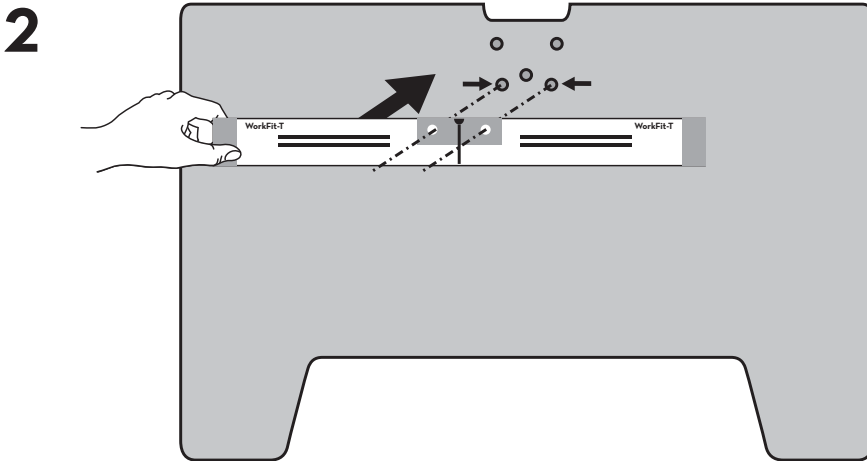
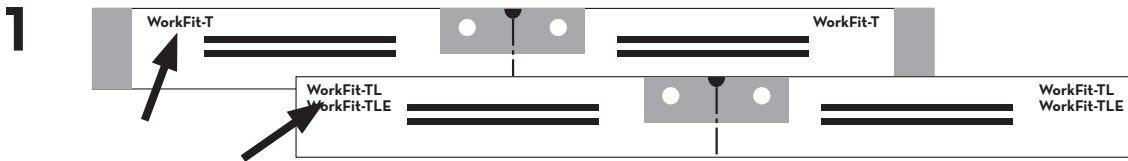

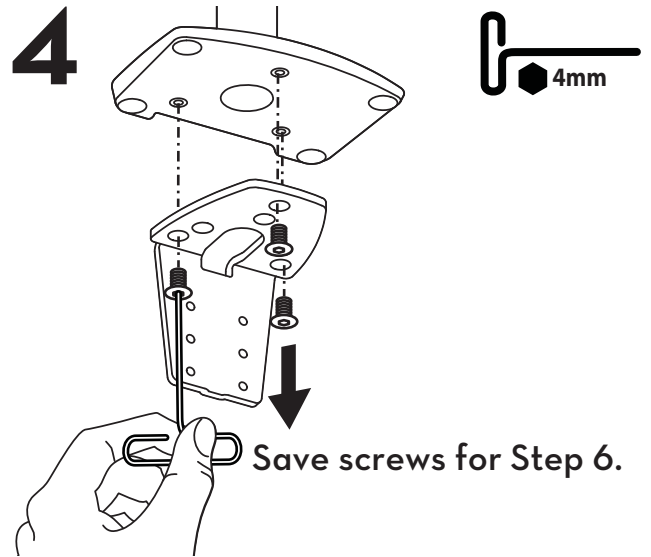
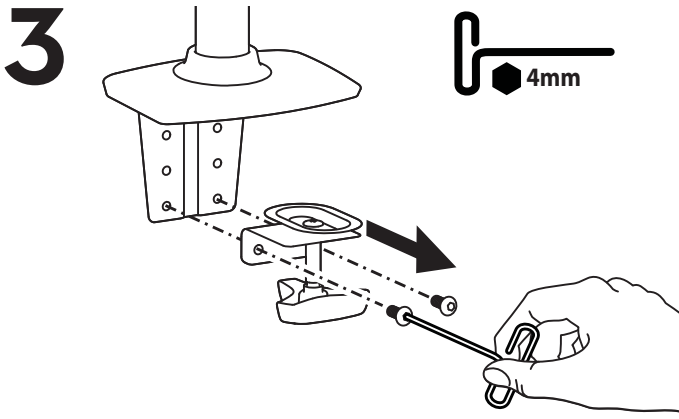

45-241/45-490
LX Desk Mount LCD
Monitor Arm

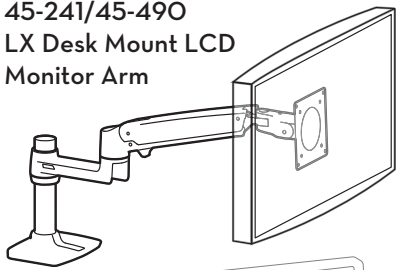

45-245/45-491
LX Dual Side-by-Side Arm

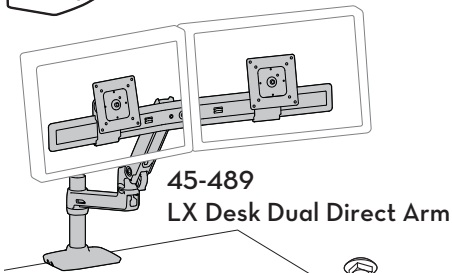
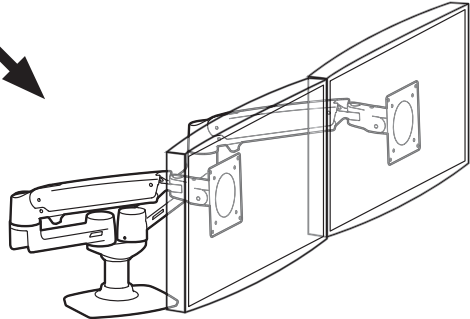

1/4-20 x 1.4"

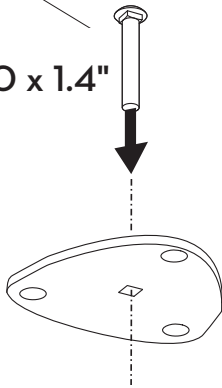

1/4-20 x 1.4"

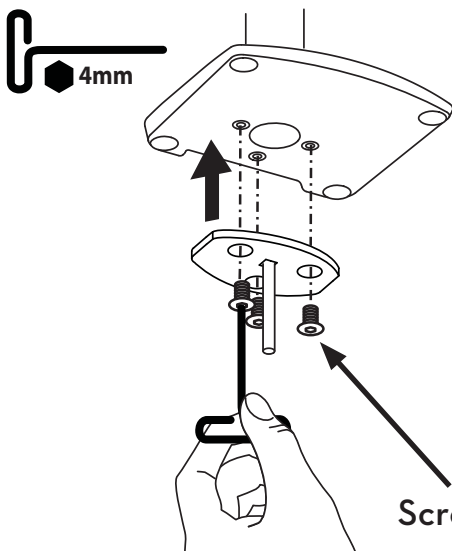
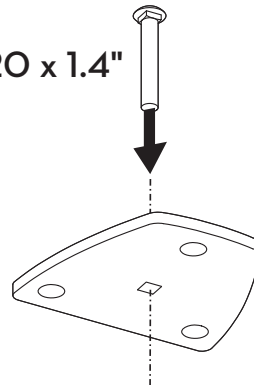

Screws from Step 4.

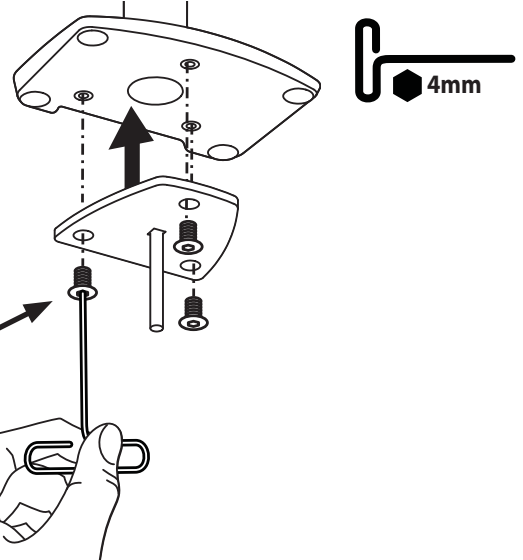

45-241/45-490
LX Desk Mount LCD
Monitor Arm

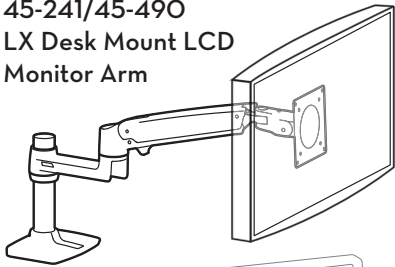

45-489
LX Desk Dual Direct Arm

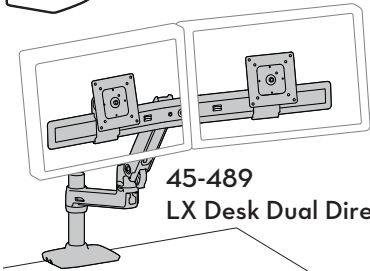

45-245/45-491
LX Dual Side-by-Side Arm

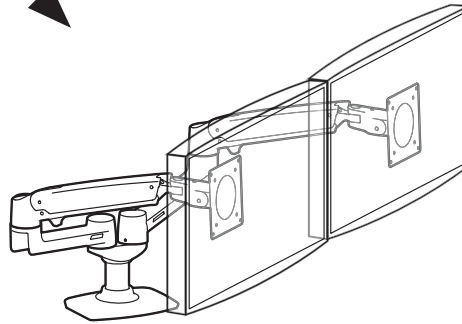

7

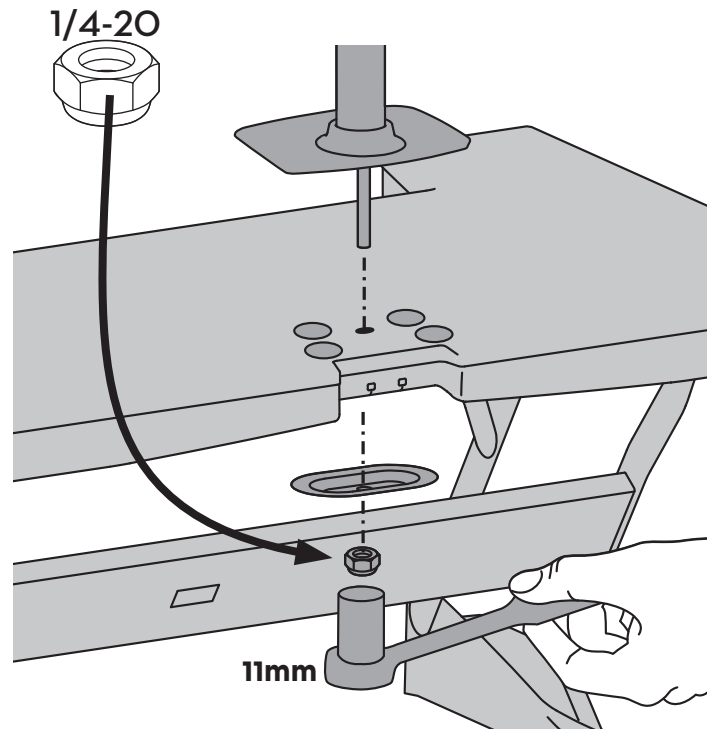
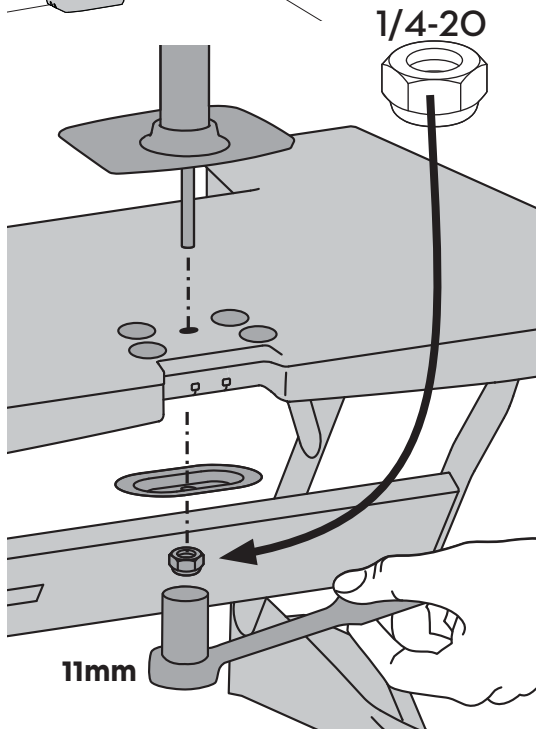

CAUTION: For secure arm attachment and to avoid equipment damage,
plate must make contact with underside of desk on both sides of the hole.
CAUTION: Bolt must be centered in hole.

For Warranty visit: www.ergotron.com/warranty

For Service visit: www.ergotron.com

For local customer care phone numbers visit: <http://contact.ergotron.com>

ergotron®

www.ergotron.com | USA: 1-800-888-8458 | Europe: +31 (0)33-45 45 600 | China: 400-120-3051 | Japan: japansupport@ergotron.com

© 2016 Ergotron, Inc. All rights reserved. WorkFit™ is a registered trademark of Ergotron, Inc.

While Ergotron, Inc. makes every effort to provide accurate and complete information on the installation and use of its products, it will not be held liable for any editorial errors or omissions (including those made in the process of translation from English to another language), or for incidental, special or consequential damages of any nature resulting from furnishing this instruction and performance of equipment in connection with this instruction. Ergotron, Inc. reserves the right to make changes in the product design and/or product documentation without notification to its users. For the most current product information, or to know if this document is available in languages other than those herein, please contact Ergotron. No part of this publication may be reproduced, stored in a retrieval system, or transmitted in any form or by any means, electronic, mechanical, photocopying, recording or otherwise without the prior written consent of Ergotron, Inc., 1181 Trapp Road, Eagan, Minnesota, 55121, USA Patents Pending and Patented U.S. & Foreign. Ergotron is a registered trademark of Ergotron, Inc.