



205 Westwood Ave, Long Branch, NJ 07740

Phone: 866-94 BOARDS (26273) / (732)-222-1511

Fax: (732)-222-7088 | E-mail: [sales@touchboards.com](mailto:sales@touchboards.com)

## The Peanut



Product	Part#
The Peanut	PT1GMPW3
The Peanut for Tablets	PT2GMPW3

NOTE: The Peanut, Tall, is shown. The tablet and keyboard are not included.

For the latest User Installation Guide please visit: [www.ergotron.com](http://www.ergotron.com)



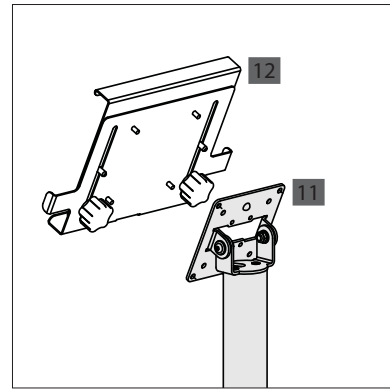
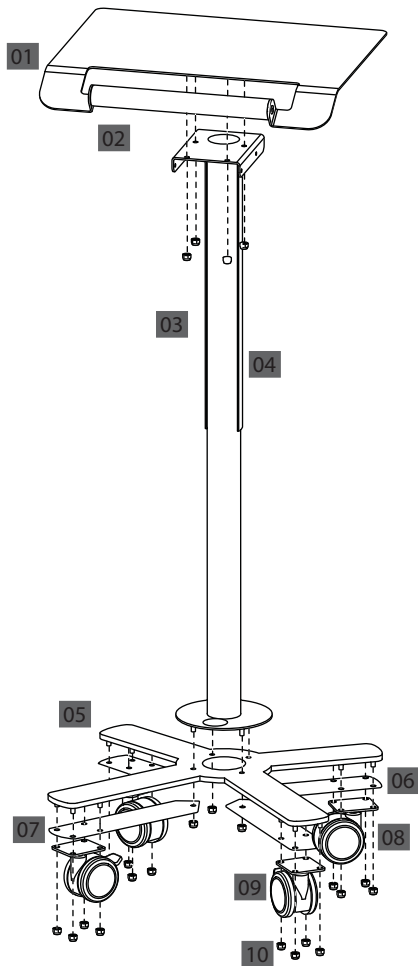

## TOOLS

The Peanut comes with these tools:

- 3-way wrench

Not provided, but suggested:

- 7/16" nut driver
- 3/8" nut driver

## PARTS LIST

Before beginning assembly of The Peanut, please review the parts list to verify that your shipment is complete.

Product	Quantity	Part Number
01 Shelf for The Peanut	1	225-4834-00
for The Peanut for Tablets		225-4837-00
02 Handle (installed on shelf)	1	125-5411-00
03 Column Assembly for The Peanut	1	500-1108-00
for The Peanut for Tablets		500-1109-00
04 Cable Sleeve	1	280-5056-00
05 Base	1	225-4833-00
06 Small Ballast Plate	2	225-6503-00
07 Large Ballast Plate	2	225-6054-00
08 Casters, Non-locking	2	150-5117-00
09 Casters, Locking	2	150-5118-00
For Peanut for Tablets: 10 1/4-20 Nylock Nut	24	325-5259-00
11 VESA Tilt Assembly for Peanut for Tablets	1	835-5639-00
12 Easel Assembly for Peanut for Tablets	1	835-5640-00
13 #10-24 x 0.75" Flat Head Screw for Peanut for Tablets (not shown)	2	325-5270-00

## STEP 1 - ATTACH THE CASTERS TO THE BASE

- Lay the base upside down on work surface or floor.
- Align the mounting holes of each ballast plate with the bolts sticking out of the base.
- Align the mounting holes in each caster plate with the bolts sticking out of the base. Locking casters (with tabs as shown) attach to the longer base legs.
- Attach each caster with four nylock nuts using a 7/16" nut driver.

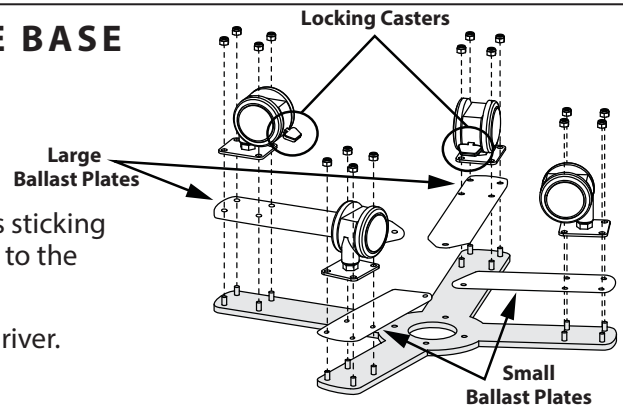

1/4-20 Nylock Nuts  
325-5259-00

## STEP 2 - ATTACH BASE TO THE COLUMN

Align mounting holes in base with bolts sticking out of the bottom of the column.

Attach the base with four nylock nuts using a 7/16" nut driver.



1/4-20 Nylock Nuts  
325-5259-00

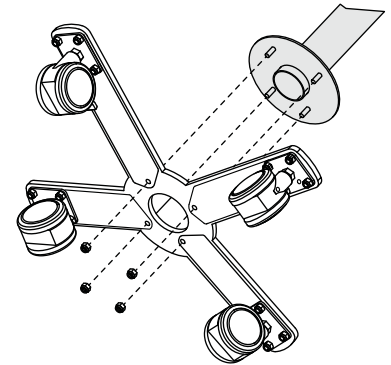

## STEP 3 - ATTACH SHELF TO COLUMN AND CABLE SLEEVE

Stand the column up on its casters.

Align mounting holes on column with bolts in shelf so the handle is over the locking casters.

Attach the shelf with four nylock nuts using a 7/16" nut driver.

Slip the Cable Sleeve over the tube and press into place.



1/4-20 Nylock Nuts  
325-5259-00

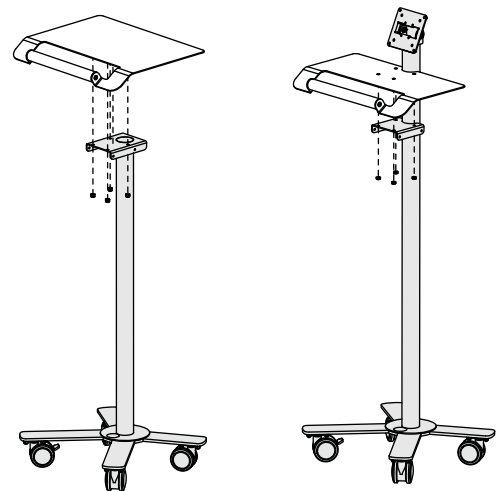

## STEP 4 - ATTACH VESA MOUNT TO COLUMN

- Rotate VESA plate on mounting assembly so it can lay flat.
- Align mounting holes in mounting assembly with holes in top of column.
- Attach VESA mounting assembly with two hex bolts using 1/8" hex key.

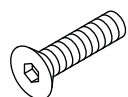

#10-24 x 0.75" Flat-hd Screw  
325-5270-00

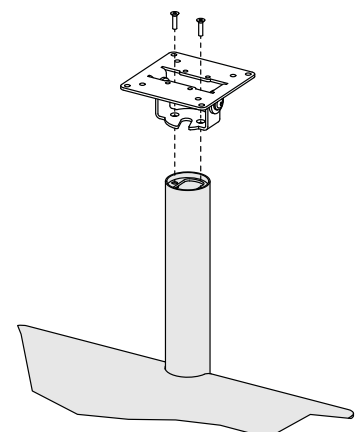

---

## STEP 5A - ATTACH DEVICE HOLDER TO VESA PLATE

- Align device holder with the VESA plate so the four threaded studs on the holder line up with four holes on the plate.
- Attach the device holder to the plate with four acorn nuts using your 3/8" driver.
- To adjust the device holder, loosen the adjustment knobs at the back of the device holder, slide the top of the holder into position, then tighten the knobs.



3/8" Acorn Nut  
325-5023-00

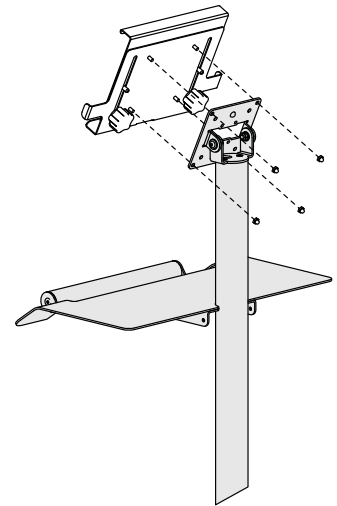

---

## STEP 5B - ATTACH TABLET CASE TO VESA PLATE

- Align the holes in the back of your tablet case with the four outer holes in the VESA mount.
- Attach monitor with mounting screws that come with the case.

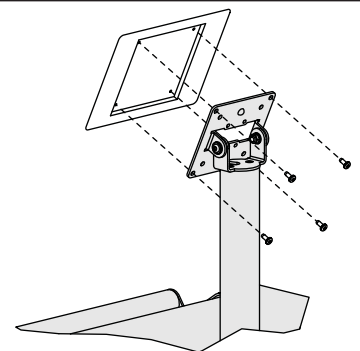

---

**CONGRATULATIONS! YOUR CART ASSEMBLY IS COMPLETE!**

For Warranty visit: [www.ergotron.com/warranty](http://www.ergotron.com/warranty)

For Service visit: [www.ergotron.com](http://www.ergotron.com)

For local customer care phone numbers visit: <http://contact.ergotron.com>

### Americas Sales and Corporate Headquarters

1181 Trapp Rd.  
St. Paul, MN USA  
1-800-325-3841  
[www.ergotron.com](http://www.ergotron.com)  
[sales@ergotron.com](mailto:sales@ergotron.com)



While Ergotron, Inc. makes every effort to provide accurate and complete information on the installation and use of its products, it will not be held liable for any editorial errors or omissions (including those made in the process of translation from English to another language), or for incidental, special or consequential damages of any nature resulting from furnishing this instruction and performance of equipment in connection with this instruction. Ergotron, Inc. reserves the right to make changes in the product design and/or product documentation without notification to its users. For the most current product information, or to know if this document is available in languages other than those herein, please contact Ergotron. No part of this publication may be reproduced, stored in a retrieval system, or transmitted in any form or by any means, electronic, mechanical, photocopying, recording or otherwise without the prior written consent of Ergotron, Inc., 1181 Trapp Road, Eagan, Minnesota, 55121, USA. Patents Pending and Patented U.S. & Foreign. Ergotron is a registered trademark of Ergotron, Inc.

© 2016 Ergotron, Inc. All rights reserved.

All trademarks are the property of their respective companies. Anthro is a registered trademark and brand of Ergotron Inc. Anthro-DNA is a trademark of Ergotron Inc.