

ASSEMBLY INSTRUCTIONS

Zido® Adjustable-Height Cart



Zido Adjustable, NO LIP	Part#
Adjustable, Heavy Load, 25" w	ZAH25CG/CG4
Adjustable, Light Load, 22" w	ZAL22CG/CG4
Adjustable, Light Load, 25" w	ZAL25CG/CG4



www.ergotron.com

USA 1-800-325-3841

For the latest User Installation Guide please visit: www.ergotron.com

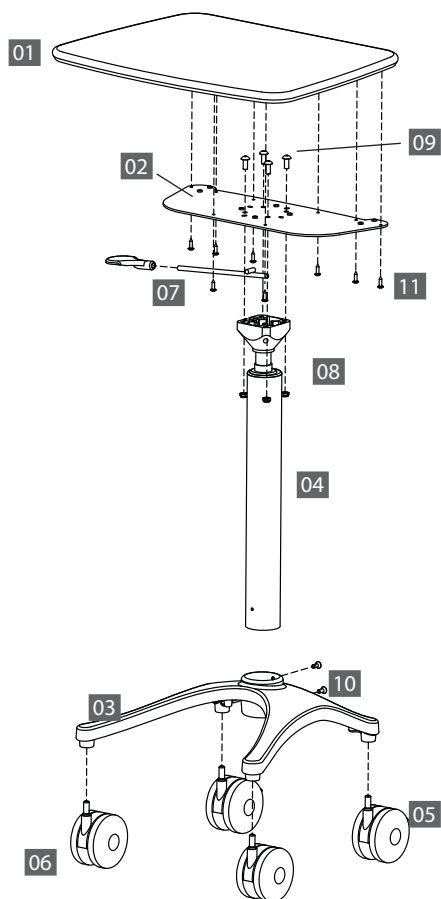

WELCOME

Thank you for purchasing this Zido Height-adjustable cart!

If you have any questions or if we can help you in any way, please contact us at 800.325.3841.

PARTS LIST

Before beginning assembly of your Zido Height-adjustable Cart, please review the parts list to verify that your shipment is complete.

Product	Quantity	Part Number
01 Cap Shelf	1	
For small cart, no lip		101-1025-06-50
For small cart, with lip		101-1072-03-50
For large cart, no lip		101-1026-06-50
For large cart, with lip		101-1073-03-50
02 Cap Shelf Bracket	1	225-2620-51
03 Base		
For Small Cart	1	250-5064-52
For Large Cart	1	250-5065-52
04 Column		
For Light Load Cart	1	835-5290-00
For Heavy Load Cart	1	835-5291-00
05 4" Non-locking Caster	2	150-5010-03
06 4" Locking Caster	2	150-5011-03
07 Release Lever and Paddle	1	835-5393-00
08 Lock Nut	4	325-5263-00
09 1" Cap Screws	4	325-5537-00
10 3/4" Flat-head Patch Screws	2	325-5466-00
11 3/4" Wood Screws	8	325-5575-00
12 3/16" Hex Key (not shown)	1	375-5028-00
13 5/32" Hex Driver (not shown)	1	375-5000-00

ASSEMBLY SEQUENCE

Plan out the assembly sequence to make your installation easier.

1. Pre-drill the top for accessories (Mouse Holder, Side Bin, Gel Cup/Probe Holder, Extension Tube).
 2. Assemble the cart.
 3. Base Storage Shelf.
 4. Drawer, Keyboard Caddy, Standard Handle.
 5. Additional Shelves, Equipment Shelves, Metal Bin.
 6. Cable Bin, Glove Box Holder.
 7. Mouse Holder, Side Bin, Gel Cup & Probe Holder, Extension Tube.
 8. 8" Handle, Flat Panel Mounts.
-

STEP 1A

Connect the Base with the Tube

- Holding the column from the center (don't push from the top) slide the tube into the base so that the tube goes all the way to the bottom of the base.
- Align the upper hole on the base with a threaded hole in the column. (For the large cart, you'll use the top hole; for the small cart, you'll use the second hole.) Loosely attach the column to the base with two 3/4" Flat-head Screw.

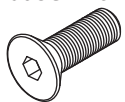

3/4" Flat Hd Screw
325-5466-00

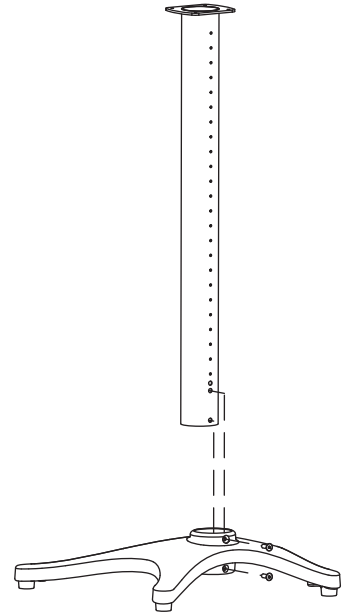

STEP 1b

Insert the Casters

- Place Zido on its side. Add the locking casters (the ones with the brakes) to the front of the base assembly. Add the non-locking casters to the back of the base assembly.

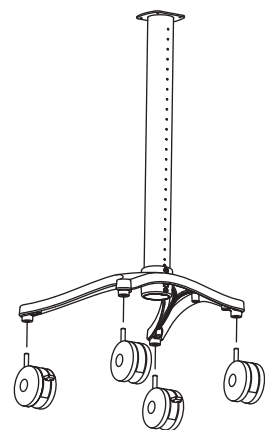

STEP 2

Install the Lever and the Top Plate

- Align the lever with the top of the trunk assembly as shown.
- Locate the bracket. The bottom of the bracket is flat and has no sticker. The top of the bracket has a sticker that says "TOP" and has bumps with threads inside. The bumps on the top of the bracket will nest inside the holes on the cap shelf.
- Align the cap shelf bracket with the trunk assembly so the bracket's tabs are at the back and the "TOP" label is on top.
- Using the 3/16 hex key, insert four 1" Socket-head Cap screws through the holes on the top of the Top Plate and capture with four lock nuts inserted in to the holes in the top of the columns.
- Pull up on the lever to move the column up and down. Repeat a few times to make sure the column moves smoothly. If the lever was installed upside down, the column won't move. If that happens, remove the top plate, invert the lever, and try it again.

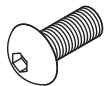
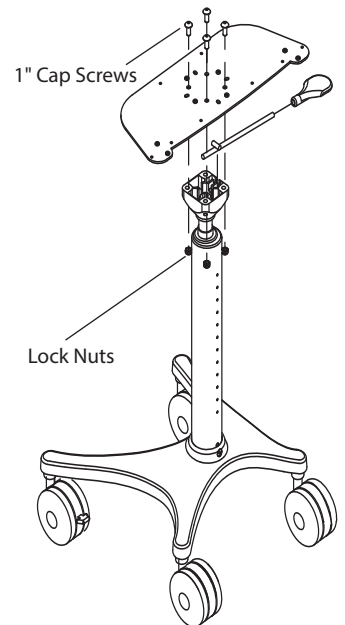

1" Button-head Screw
325-5537-00



Lock Nut
325-5263-00

STEP 3

Install the Cap Shelf

- Align the indentations on the bottom of the cap shelf with the screw heads and bumps on the top of the top plate.
- Secure the cap shelf to the cart with eight 3/4" wood screws.
- Tighten the 3/4" flat-head screws that connect the column to the base.
- Pull the paddle up and move the column up and down a few times to loosen the mechanism. Be sure to operate the column from the back of the cart so you have plenty of leverage.



3/4" Button Hd PB Screw
325-5575-00

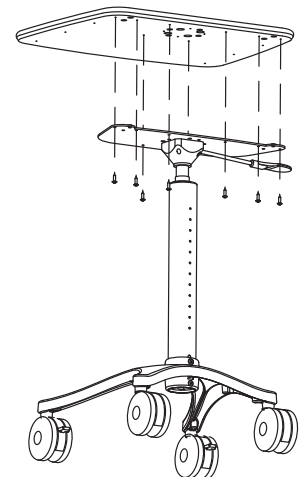

**CONGRATULATIONS!
YOUR ZIDO ADJUSTABLE CART ASSEMBLY IS COMPLETE!**

For Warranty visit: www.ergotron.com/warranty

For Service visit: www.ergotron.com

For local customer care phone numbers visit: <http://contact.ergotron.com>

Americas Sales and Corporate Headquarters

1181 Trapp Rd.
St. Paul, MN USA
1-800-325-3841
www.ergotron.com
sales@ergotron.com

ERGOTRON[®]



While Ergotron, Inc. makes every effort to provide accurate and complete information on the installation and use of its products, it will not be held liable for any editorial errors or omissions (including those made in the process of translation from English to another language), or for incidental, special or consequential damages of any nature resulting from furnishing this instruction and performance of equipment in connection with this instruction. Ergotron, Inc. reserves the right to make changes in the product design and/or product documentation without notification to its users. For the most current product information, or to know if this document is available in languages other than those herein, please contact Ergotron. No part of this publication may be reproduced, stored in a retrieval system, or transmitted in any form or by any means, electronic, mechanical, photocopying, recording or otherwise without the prior written consent of Ergotron, Inc., 1181 Trapp Road, Eagan, Minnesota, 55121, USA. Patents Pending and Patented U.S. & Foreign. Ergotron is a registered trademark of Ergotron, Inc.

© 2016 Ergotron, Inc. All rights reserved.

All trademarks are the property of their respective companies. Anthro is a registered trademark and brand of Ergotron Inc. Anthro-DNA is a trademark of Ergotron Inc.