

THE DUAL KANGAROO

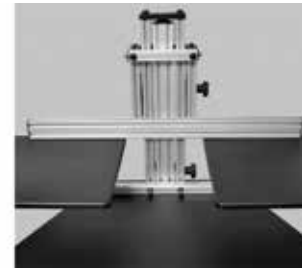
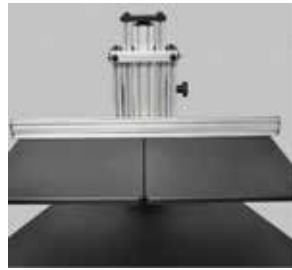

Loosen the bolts under the shelves just enough to allow the shelf to move(usually half a turn).

Your Dual Kangaroo is shipped with the two monitor shelves pushed together. Depending on the size of the monitors you are going to use, you may need to spread them out to allow your monitors to sit properly.

Underneath the shelves you will find four bolts in each shelf. Loosen the bolts just a little(usually half a turn) and this will allow the shelves to slide apart. Once you have them where you like, just tighten the bolts. You will need a 7/16 wrench or an adjustable wrench.

Always push down with both hands on the horizontal rear rail when lowering the work surface.

HOW TO USE THE DUAL KANGAROO

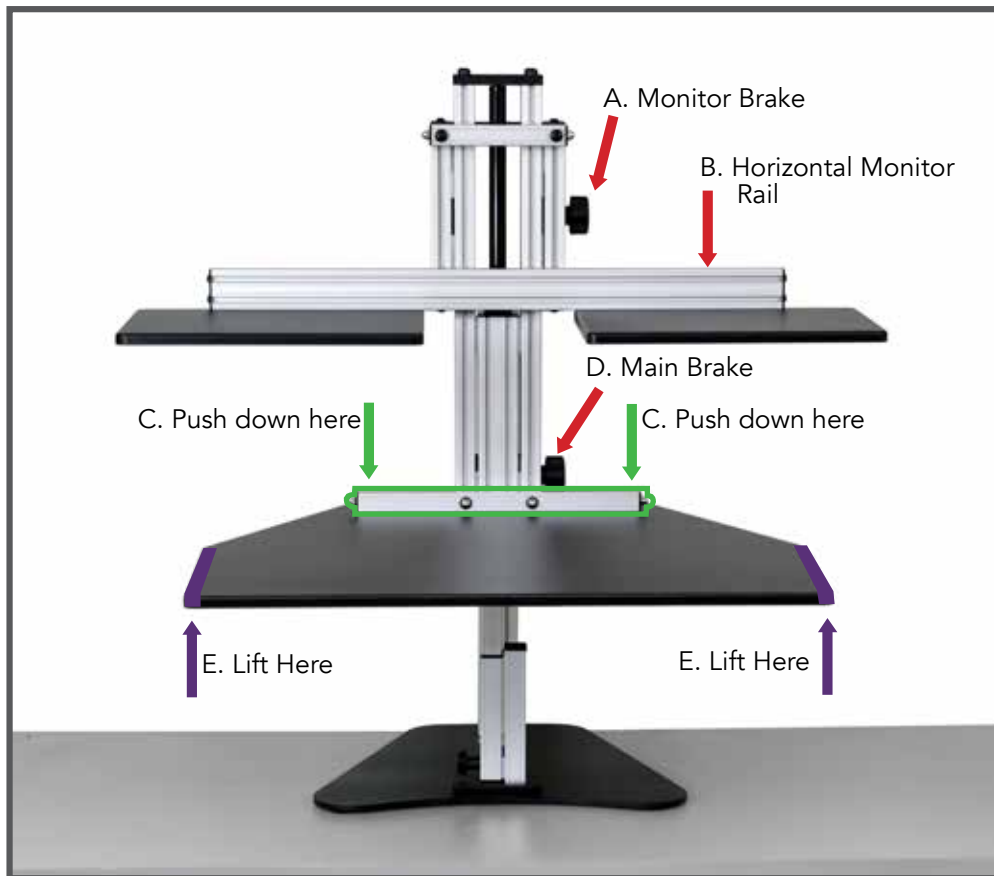

To raise the Dual, loosen the main brake(D) and lift the main work surface on the sides(E & E).

To lower the Dual, loosen the main brake(D) and lean into the unit using your upper body weight pushing down with both hands on the horizontal bar at the rear of the main work surface (C & C).

Raise and lower the monitor shelves by loosening the monitor brake(A) and either lift up or push down on the monitor rail(B).

A. Monitor Brake

B. Horizontal Monitor Rail

C. Work Surface Rail

D. Main Brake

E. Main Work Surface

ADJUST THE STOPPING BOLT

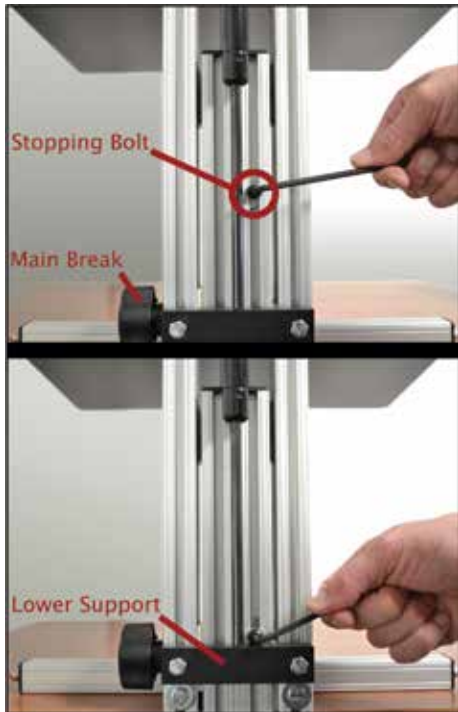

On the back side of your unit you will notice a small bolt located on the lifting tower. This bolt is used as our work surface stopper. It is currently set at 15", the highest our unit should go. This setting is for a 6'2" user on a 30" high desk. If you are shorter than this, raise the unit to your desired height and tighten the Main Brake. Adjust the stopping bolt by loosening the bolt **with one turn** and drop the bolt down to reach the lower support, and re-tighten the stopping bolt.

If you are a taller individual and need to raise the stopping bolt, please note that the work surface can get up to 16 1/2 inches but you will be raising the unit into the oil dampening zone of the spring. This makes it a little more difficult to lower the unit into the seated position when raised to this maximum point.

Our work surface should only be raised to your belt or navel line. This creates a 90-110 degree angle in your elbows which is suggested in the standing position. This will also allow you to lower the unit with ease by simply transferring your upper body weight into the back of the unit.

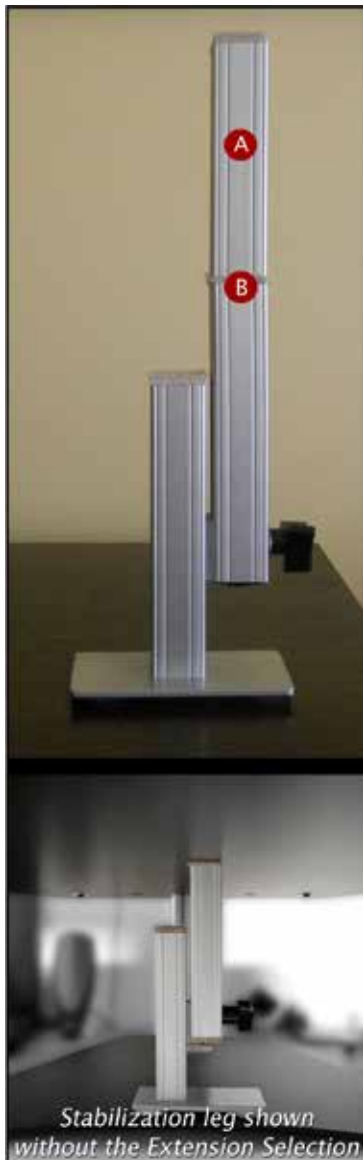

THE STABILIZATION LEG

Your adjustable height desk top unit comes with an adjustable leg that can be used to give you maximum stability when you are using "The Kangaroo" in the standing position.

Raise the Kangaroo work surface to your desired standing height and tighten the work surface brake.

Place the adjustable leg under the work surface and loosen the adjustable leg brake. Only loosen the brake by a turn or two, too much and the brake will disengage from the slot.

Extend the adjustable leg until it engages the bottom of the work surface and then tighten the adjustable leg brake.

The leg is shipped with the extension section installed to give you additional height adjustment. If this is too tall for your application, simply unscrew the extension selection.

A Extension selection

B Screws into here

ALWAYS TO REMOVE THE STABILIZATION LEG BEFORE LOWERING YOUR WORK SURFACE