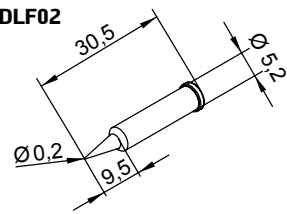
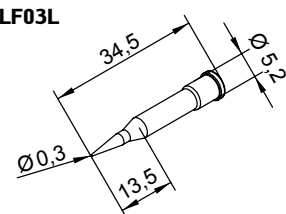
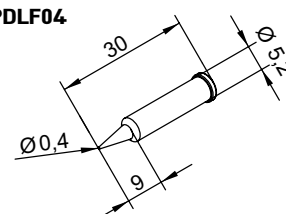
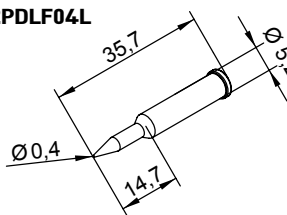
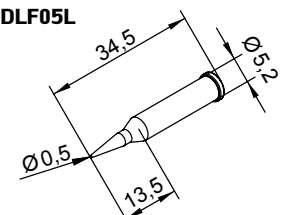
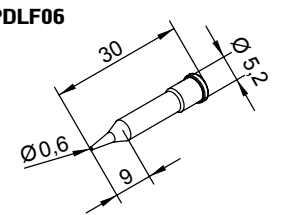
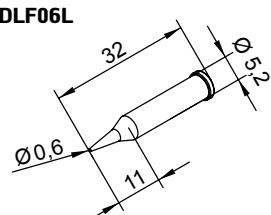
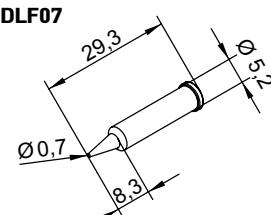
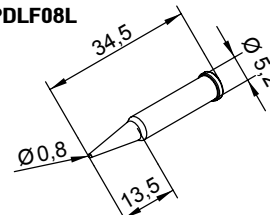
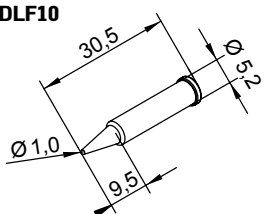
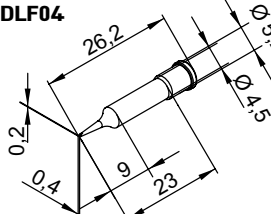
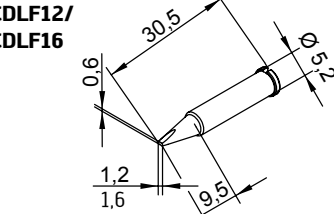
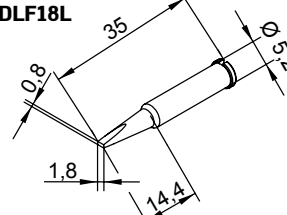
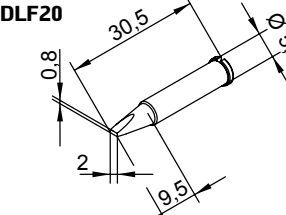
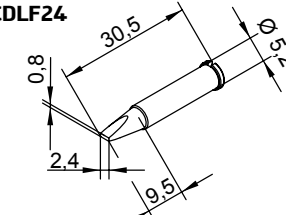
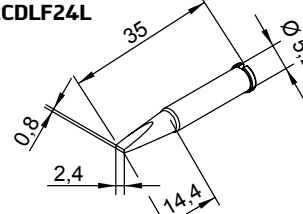
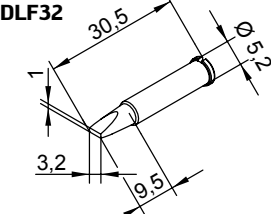
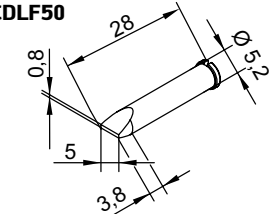

# ERSADUR long-life soldering tip series 102

Large selection ranging from 0.2 mm to 25 mm

Lead-free Bleifrei  
SAFE 

- i-CON PICO
- i-CON NANO
- i-CON with i-TOOL soldering iron
- i-CON1 with i-TOOL soldering iron
- i-CON2 with i-TOOL soldering iron
- i-CON1 C with i-TOOL soldering iron
- i-CON2 C with i-TOOL soldering iron
- i-CON VARIO 2 with i-TOOL soldering iron
- i-CON VARIO 4 with i-TOOL soldering iron

<p><b>0102PDLF02</b></p>  <p>pencil point, 0.2 mm <math>\varnothing</math></p>	<p><b>0102PDLF03L</b></p>  <p>pencil point, extended, 0.3 mm <math>\varnothing</math></p>	<p><b>0102PDLF04</b></p>  <p>pencil point, 0.4 mm <math>\varnothing</math></p>
<p><b>0102PDLF04L</b></p>  <p>pencil point, extended, 0.4 mm <math>\varnothing</math></p>	<p><b>0102PDLF05L</b></p>  <p>pencil point, extended, 0.5 mm <math>\varnothing</math></p>	<p><b>0102PDLF06</b></p>  <p>pencil point, 0.6 mm <math>\varnothing</math></p>
<p><b>0102PDLF06L</b></p>  <p>pencil point, extended, 0.6 mm <math>\varnothing</math></p>	<p><b>0102PDLF07</b></p>  <p>pencil point, 0.7 mm <math>\varnothing</math></p>	<p><b>0102PDLF08L</b></p>  <p>pencil point, extended, 0.8 mm <math>\varnothing</math></p>
<p><b>0102PDLF10</b></p>  <p>pencil point, 1.0 mm <math>\varnothing</math></p>	<p><b>0102CDLF04</b></p>  <p>chisel-shaped, 0.4 mm</p>	<p><b>0102CDLF12/ 0102CDLF16</b></p>  <p>chisel-shaped, 1.2 mm/1.6 mm</p>
<p><b>0102CDLF18L</b></p>  <p>chisel-shaped, extended, 1.8 mm</p>	<p><b>0102CDLF20</b></p>  <p>chisel-shaped, 2.0 mm</p>	<p><b>0102CDLF24</b></p>  <p>chisel-shaped, 2.4 mm</p>
<p><b>0102CDLF24L</b></p>  <p>chisel-shaped, extended, 2.4 mm</p>	<p><b>0102CDLF32</b></p>  <p>chisel-shaped, 3.2 mm</p>	<p><b>0102CDLF50</b></p>  <p>chisel-shaped, 5.0 mm</p>

# ERSADUR long-life soldering tip series 102

Wide range of special tips online at: [www.ersa.com](http://www.ersa.com)

Lead-free  
Bleifrei  
SAFE 

- i-CON PICO
- i-CON NANO
- i-CON with i-TOOL soldering iron
- i-CON1 with i-TOOL soldering iron
- i-CON2 with i-TOOL soldering iron
- i-CON1 C with i-TOOL soldering iron
- i-CON2 C with i-TOOL soldering iron
- i-CON VARIO 2 with i-TOOL soldering iron
- i-CON VARIO 4 with i-TOOL soldering iron

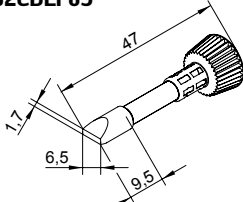
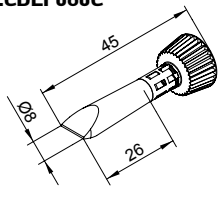
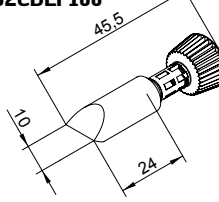
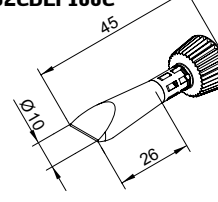
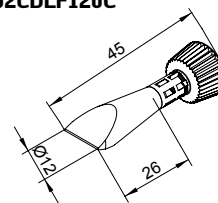
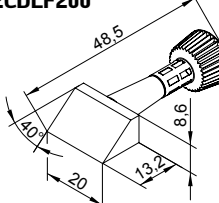
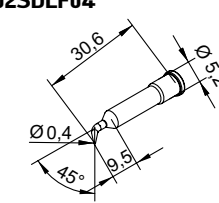
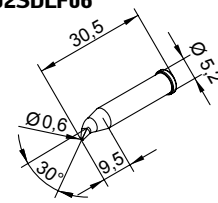
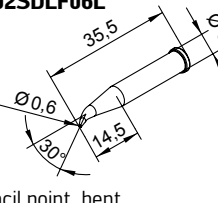
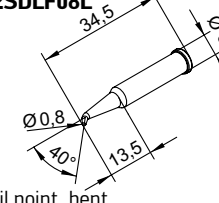
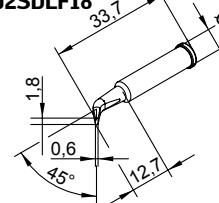
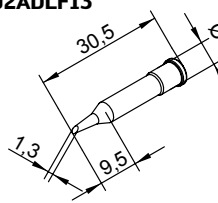
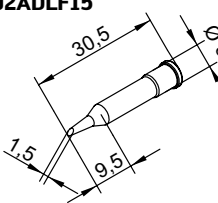
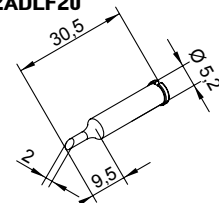
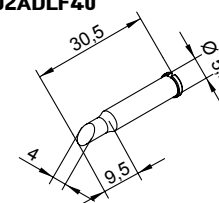
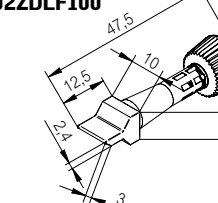
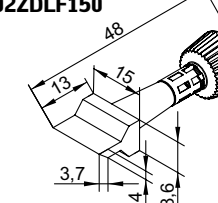
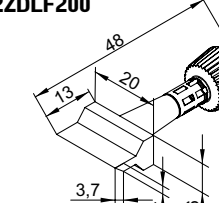
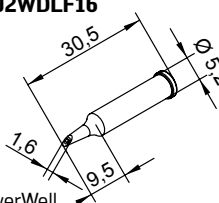
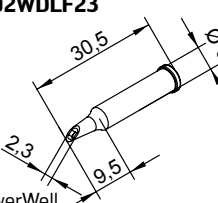
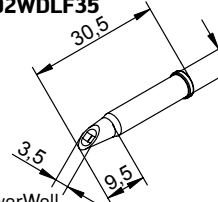
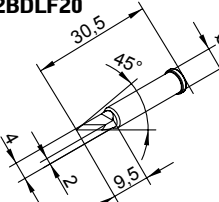
<p><b>0102CDLF65</b></p>  <p>chisel-shaped, 6.5 mm</p>	<p><b>0102CDLF080C</b></p>  <p>chisel-shaped, 8.0 mm</p>	<p><b>0102CDLF100</b></p>  <p>chisel-shaped, 10.0 mm</p>	<p><b>0102CDLF100C</b></p>  <p>chisel-shaped, conical, 10.0 mm</p>
<p><b>0102CDLF120C</b></p>  <p>chisel-shaped, conical, 12.0 mm</p>	<p><b>0102CDLF200</b></p>  <p>chisel-shaped, 20.0 mm</p>	<p><b>0102SDLF04</b></p>  <p>pencil point, bent, 0.4 mm <math>\varnothing</math></p>	<p><b>0102SDLF06</b></p>  <p>pencil point, bent, 0.6 mm</p>
<p><b>0102SDLF06L</b></p>  <p>pencil point, bent, extended, 0.6 mm <math>\varnothing</math></p>	<p><b>0102SDLF08L</b></p>  <p>pencil point, bent, extended, 0.8 mm <math>\varnothing</math></p>	<p><b>0102SDLF18</b></p>  <p>chisel-shaped, bent, 1.8 mm <math>\varnothing</math></p>	<p><b>0102ADLF13</b></p>  <p>angled face, 1.3 mm <math>\varnothing</math></p>
<p><b>0102ADLF15</b></p>  <p>angled face, 1.5 mm <math>\varnothing</math></p>	<p><b>0102ADLF20</b></p>  <p>angled face, 2.0 mm <math>\varnothing</math></p>	<p><b>0102ADLF40</b></p>  <p>angled face, 4.0 mm <math>\varnothing</math></p>	<p><b>0102ZDLF100</b></p>  <p>Wick-Tip, 10.0 mm</p>
<p><b>0102ZDLF150</b></p>  <p>Wick-Tip, 15.0 mm</p>	<p><b>0102ZDLF200</b></p>  <p>Wick-Tip, 20.0 mm</p>	<p><b>0102WDLF16</b></p>  <p>PowerWell with concave portion, 1.6 mm <math>\varnothing</math></p>	<p><b>0102WDLF23</b></p>  <p>PowerWell with concave portion, 2.3 mm <math>\varnothing</math></p>
<p><b>0102WDLF35</b></p>  <p>PowerWell with concave portion, 3.5 mm <math>\varnothing</math></p>	<p><b>0102BDLF20</b></p>  <p>PLCC blade</p>		