

# ERSADUR long-life soldering tip series 212

Lead-free  
Bleifrei  
SAFE 

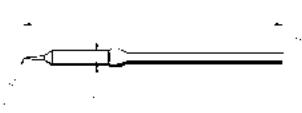

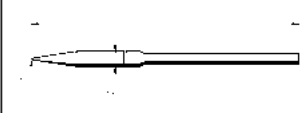
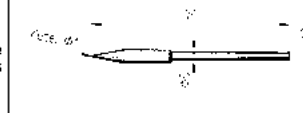
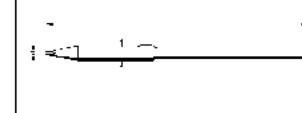
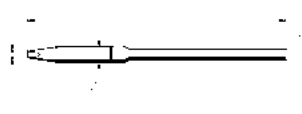
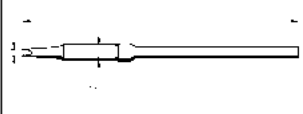
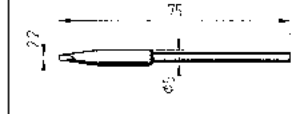
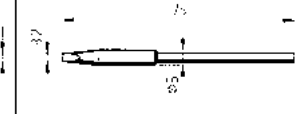
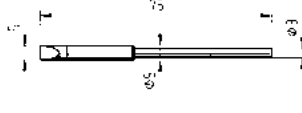
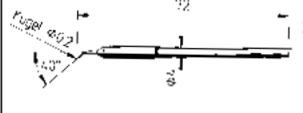
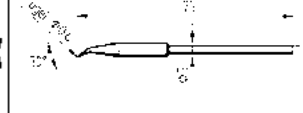
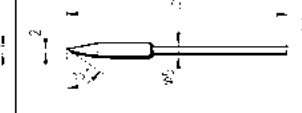
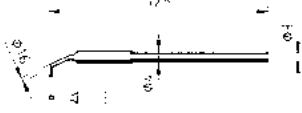
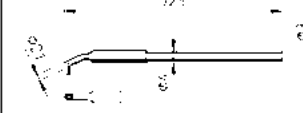
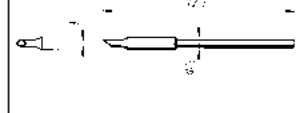

- ANALOG 20 A
- DIGITAL 2000 A with MICRO TOOL soldering iron
- MICRO-CON 60 iA with MICRO TOOL soldering iron
- REWORK 80
- SMD 8000
- SMT UNIT 60 A/AS
- TWIN 40 A/AS
- TWIN 80 A with MICRO TOOL soldering iron

<p><b>0212SDLF</b></p>  <p>pencil point, 0.2 mm <math>\varnothing</math></p>	<p><b>0212BDLF</b></p>  <p>pencil point, 0.4 mm <math>\varnothing</math></p>	<p><b>0212ADLF</b></p>  <p>pencil point, 1.0 mm <math>\varnothing</math>, reinforced</p>	<p><b>0212CDLF</b></p>  <p>chisel-shaped, 1.0 mm</p>
<p><b>0212EDLF</b></p>  <p>chisel-shaped, 1.8 mm</p>	<p><b>0212KDLF</b></p>  <p>chisel-shaped, 1.8 mm, extended</p>	<p><b>0212FDLF</b></p>  <p>chisel-shaped, 2.2 mm, reinforced</p>	<p><b>0212GD</b></p>  <p>chisel-shaped, 3.2 mm, reinforced</p>
<p><b>0212VD</b></p>  <p>chisel-shaped, 5.0 mm, reinforced</p>	<p><b>0212RD</b></p>  <p>pencil point, 0.2 mm <math>\varnothing</math>, bent</p>	<p><b>0212ID</b></p>  <p>bent, 0.6 mm <math>\varnothing</math>, reinforced</p>	<p><b>0212ND</b></p>  <p>angled face, 2.0 mm, reinforced</p>
<p><b>0212WD</b></p>  <p>MiniMicroWell, 1.6 mm <math>\varnothing</math></p>	<p><b>0212MS</b></p>  <p>MicroWell, 2.1 mm <math>\varnothing</math></p>	<p><b>0212OD</b></p>  <p>SolderWell, 3.0 mm <math>\varnothing</math></p>	

# Pairs of desoldering tips, series 462

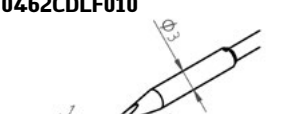
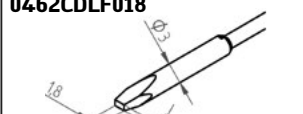
Lead-free  
Bleifrei  
SAFE 

- i-CON VARIO 2
- i-CON 2 V
- i-CON VARIO 4  
with CHIP TOOL VARIO

<p><b>0462CDLF010</b></p>  <p>chisel-shaped, 1 mm</p>	<p><b>0462CDLF018</b></p>  <p>chisel-shaped, 1.8 mm</p>	<p><b>0462MDLF007</b></p>  <p>chisel-shaped, 0.7 mm, bent</p>	<p><b>0462MDLF015</b></p>  <p>chisel-shaped, 1.5 mm, bent</p>
<p><b>0462SDLF002</b></p>  <p>pencil point, 0.2 mm <math>\varnothing</math>, bent</p>	<p><b>0462PDLF005</b></p>  <p>pencil point, 0.5 mm <math>\varnothing</math></p>		