

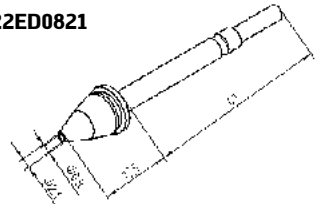

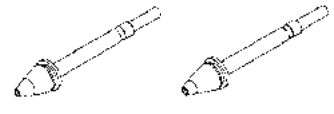
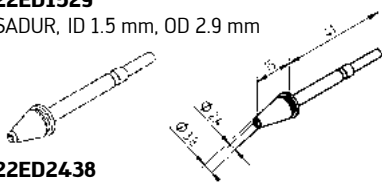
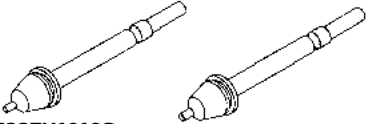

ERSADUR/nickel-plated desoldering tip series 722

Lead-free
Bleifrei
SAFE 

- DIGITAL 2000 A with X-TOOL desoldering iron
- XT00LKIT1
- i-CON with X-TOOL desoldering iron
- i-CON2 with X-TOOL desoldering iron
- i-CON2 C with X-TOOL desoldering iron

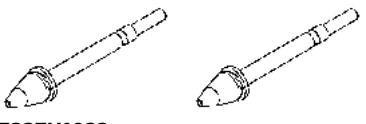
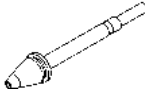
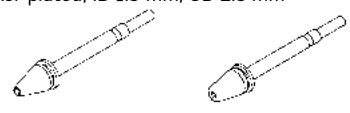
<p>0722ED0821</p>  <p>ERSADUR, ID 0.8 mm, OD 2.1 mm</p>	<p>0722ED1023 ERSADUR, ID 1.0 mm, OD 2.3 mm</p>  <p>0722ED1226 ERSADUR, ID 1.2 mm, OD 2.6 mm</p>	<p>0722ED1529 ERSADUR, ID 1.5 mm, OD 2.9 mm</p>  <p>0722ED2438 ERSADUR, ID 2.4 mm, OD 3.8 mm</p>
<p>0722EN0615S nickel-plated, ID 0.6 mm, OD 1.5 mm</p>  <p>0722EN1018S nickel-plated, ID 1.0 mm, OD 1.8 mm</p>	<p>0722ED1023 nickel-plated, ID 1.0 mm, OD 2.3 mm</p>  <p>0722EN0823 nickel-plated, ID 0.8 mm, OD 2.3 mm</p>	<p>0722EN1020 nickel-plated, ID 1.0 mm, OD 2.0 mm</p>  <p>0722EN1023 nickel-plated, ID 1.0 mm, OD 2.3 mm</p>
<p>0722EN1223</p>  <p>nickel-plated, ID 1.2 mm, OD 2.3 mm</p>	<p>0722EN1529 nickel-plated, ID 1.5 mm, OD 2.9 mm</p>  <p>0722EN1548 nickel-plated, ID 1.5 mm, OD 4.8 mm</p>	<p>0722EN2332 nickel-plated, ID 2.3 mm, OD 3.2 mm</p>  <p>0722EN2348 nickel-plated, ID 2.3 mm, OD 4.8 mm</p>

ERSADUR/nickel-plated desoldering tip series 742

Lead-free
Bleifrei
SAFE 

- i-CON VARIO with X-TOOL VARIO desoldering iron
- i-CON 2V

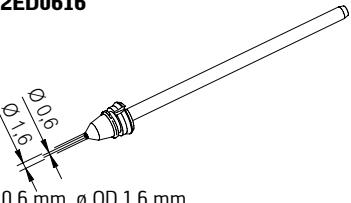
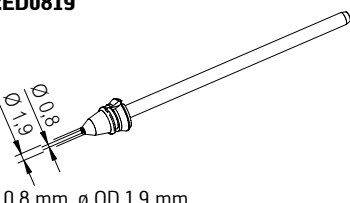
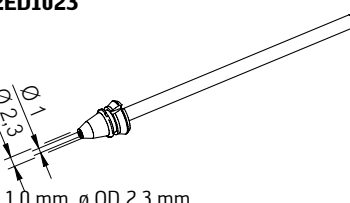
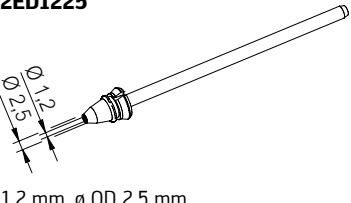
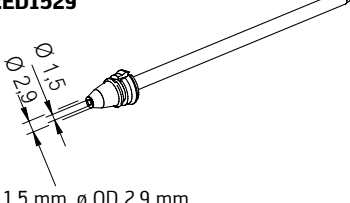
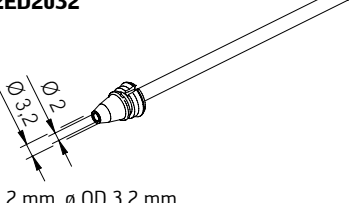
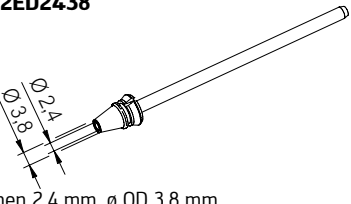
<p>0742ED0616</p>  <p>ø ID 0,6 mm, ø OD 1,6 mm</p>	<p>742ED0819</p>  <p>ø ID 0,8 mm, ø OD 1,9 mm</p>	<p>742ED1023</p>  <p>ø ID 1,0 mm, ø OD 2,3 mm</p>
<p>0742ED1225</p>  <p>ø ID 1,2 mm, ø OD 2,5 mm</p>	<p>742ED1529</p>  <p>ø ID 1,5 mm, ø OD 2,9 mm</p>	<p>742ED2032</p>  <p>ø ID 2 mm, ø OD 3,2 mm</p>
<p>0742ED2438</p>  <p>ø innen 2,4 mm, ø OD 3,8 mm</p>		

Dimensions without pre-tinning