

## Technical Specifications

38941 Evolution TIC

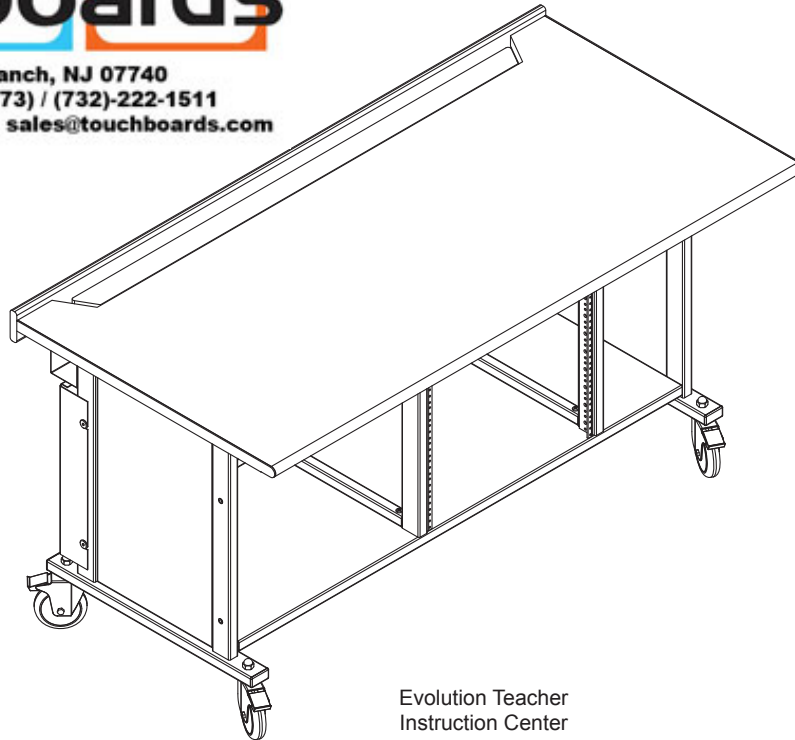

205 Westwood Ave, Long Branch, NJ 07740  
Phone: 866-94 BOARDS (26273) / (732)-222-1511  
Fax: (732)-222-7088 | E-mail: sales@touchboards.com



Evolution Teacher  
Instruction Center  
38941BW

*Beautiful teachers desks with a generous capacity for technology – Evolution Teachers Instruction Centers are complete mobile computer desks. A professional rack rail system lies underneath the work surface, keeping audio visual equipment safer and easier to use than stacking on a shelf. These are anything but ordinary teachers desks - Spectrum's Teachers Instruction Center is really a classroom control station.*

## Features and Benefits

- 5" swivel locking Balloon Wheels (BW) casters or 4" swivel locking Casters (C) provide mobility for easy transport between classrooms
- Scratch and impact resistant 1 1/8" high-pressure laminate work surface
- Flip-top work surface door for easy cable and wire access
- User-friendly bullnose radiused front edge on work surface
- Cord channel conveniently keeps computer wires and cables out of the way and is wide enough for most power strips
- Includes one standard 6-outlet power strip
- Includes one set of rack rails (12RU)
- Solid oak chair rail protects wires and the back of the unit
- Removable audience-side panel provides security and access to equipment
- Optional keyboard tray can be installed under the work surface
- Optional locking front door kit provides security (not compatible with optional keyboard tray)
- Wide variety of options and rack-mount accessories allow unit to be configured to most situations
- Warranted to be free of all defects in materials and workmanship with a 10-year warranty

Base Options	
BW - 5" Balloon Wheels	
C - 4" Casters	

Options & Accessories	
Page 5	

### Color Options

Standard laminate / color combinations

Wild Cherry / Black (CHB)	
Bannister Oak / Putty (KP)	
Indigo Organix / Dark Gray (ID)	

Standard color combination refers to the quickest deliverable product color combination. Custom laminates and color combinations are available-additional lead-times and up-charges may apply. Call 1-800-235-1262 for further information.

# Construction

- The worksurface is constructed from 1<sup>1</sup>/<sub>16</sub>" thick NAUF (No Added Urea Formaldehyde) composite board with .030 high-pressure laminate on one face, and a balancing phenolic backer on the opposing face
- Left and right-side worksurface edges are finished with 3mm vinyl edge-band
- All metal components are finished with a scratch-resistant powder coat epoxy
- Welded, 16-gauge 1" x 2" rectangular steel tube legs
- Bottom leg rails include weld-nuts for attaching wheels
- 20-gauge cord channel/modesty panel and leg insert panels
- Chair rail is 1/4" #1 select red oak, finished with a catalyzed top coat
- Post-formed bullnose on worksurface front edge
- Each TIC is shipped knocked-down (KD) and requires assembly

# Capacity

Worksurface (uninterrupted depth)	60"W x 26"D
Cord channel	3"D x 4 <sup>3</sup> / <sub>4</sub> "H
CPU area	8 <sup>13</sup> / <sub>16</sub> "W x 17 <sup>15</sup> / <sub>16</sub> "D x 21 <sup>3</sup> / <sub>4</sub> "H
Standard rack rail	12RU
5" balloon wheels	weight capacity 325 lbs each
4" casters	weight capacity 255 lbs each
Unit weight (nominal)	131 lbs
Shipping weight (nominal)	162 lbs
Meets or exceeds all ANSI-BIFMA test standards	

Specifications subject to change without notice

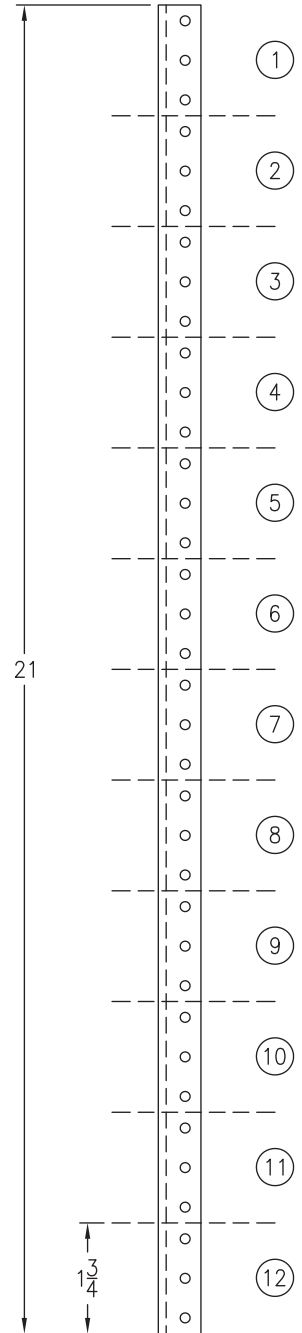
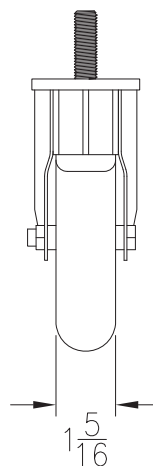
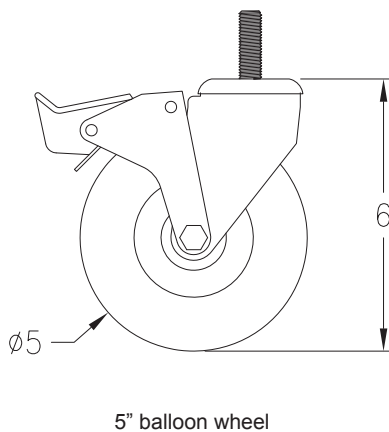
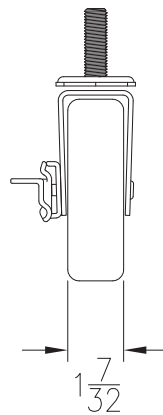
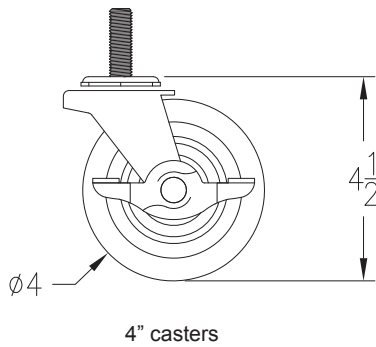

12RU available

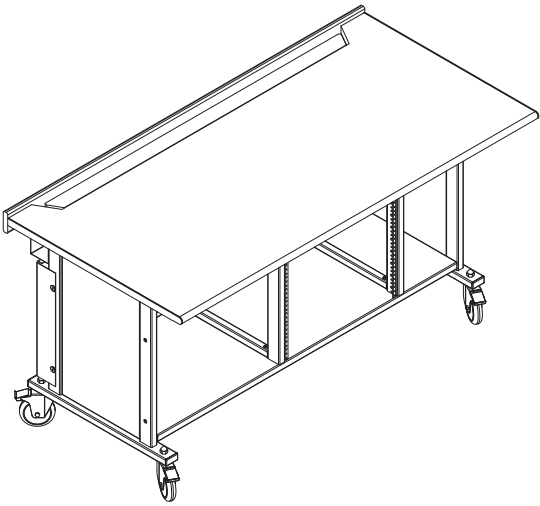

Evolution Teacher Instruction Center  
with Balloon Wheels

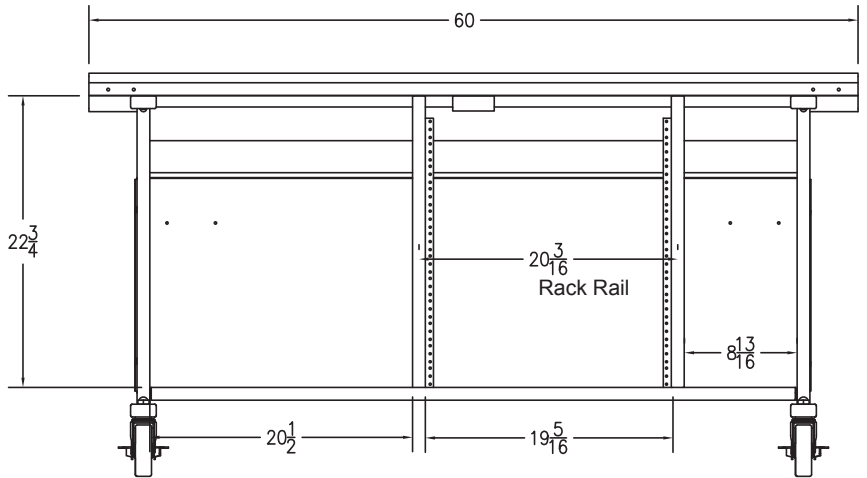
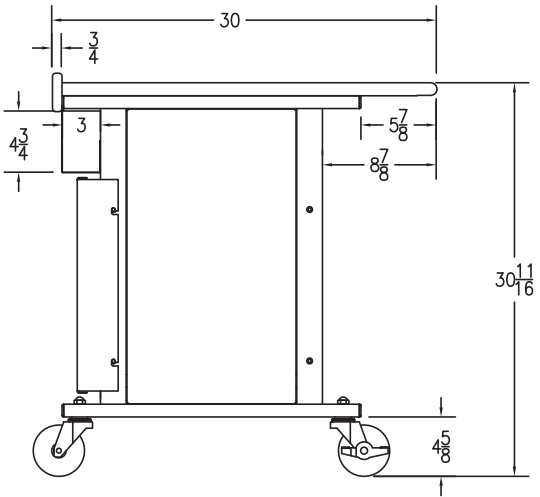
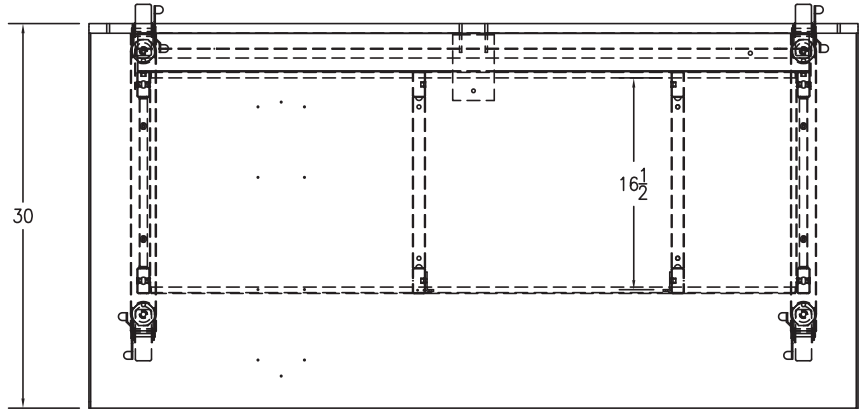

Note: Modified worksurface cutouts should be reviewed by Spectrum to ensure clearance of brackets, keyboard slides, or other objects under the worksurface.

Evolution Teacher Instruction Center  
section view

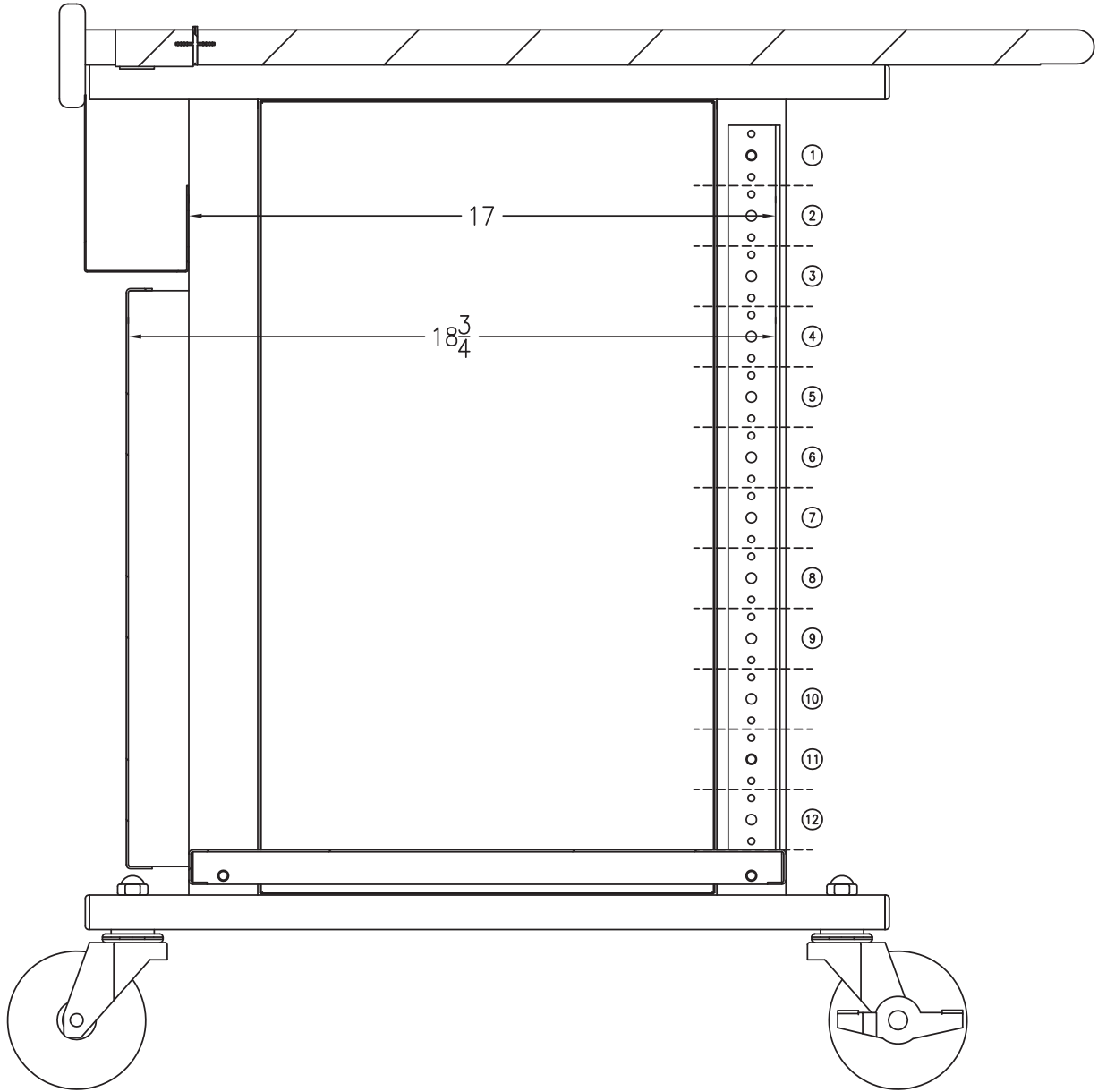

Note: Rack-mount accessories with a depth greater than  $18\frac{3}{4}$ "D will not fit in the TIC. Check the dimensions of all equipment before installation.

# Options

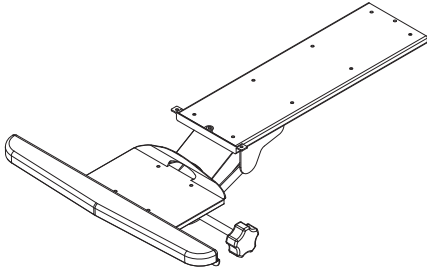

**Econo Keyboard Tray**  
18 $\frac{3}{4}$ "W x 12"D  
95520

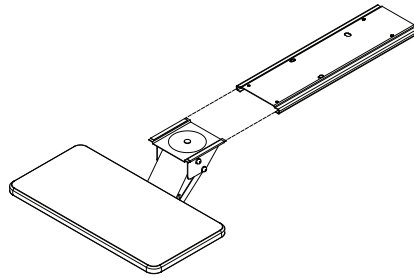

**Micro-Arm Keyboard Tray**  
moves in, out, up & down  
19 $\frac{3}{4}$ "W x 10"D  
95506

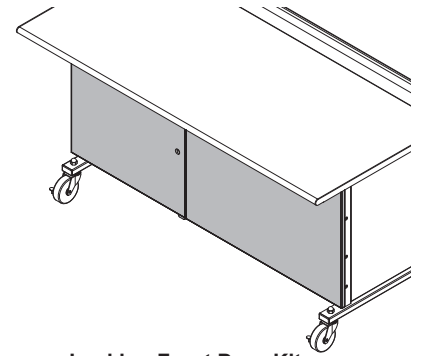

**Locking Front Door Kit**  
38944

Note: Not compatible with optional keyboard trays.

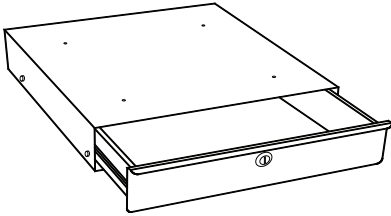

**Universal Laptop Drawer**  
16"W x 17 $\frac{1}{2}$ "D x 3 $\frac{1}{2}$ "H  
95510

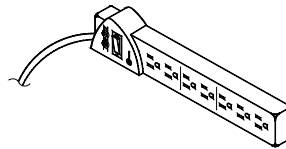

**7-Outlet Power Strip, insured**  
w/ surge protector, and 12' cord  
10"W x 2"D x 1 $\frac{1}{8}$ "H  
99024

A small diagram showing a monitor arm mounted to a wall panel.

**Flat Panel Monitor Arms & Tablet Mounts**  
(See the Spectrum website or catalog for the latest available monitor arm & tablet mounting options)

# Rack-mount accessories

Note: Rack-mount accessories with a depth greater than 18 $\frac{3}{4}$ "D will not fit in the TIC. Check the dimensions of all equipment before installation. The following Spectrum rack-mount accessories will not fit the TIC:

97517 - LT-4 Laptop Storage Unit  
97503 - Pull-out Shelf (3RU)

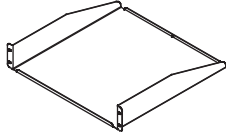

**Cantilever Shelf (2RU)**  
17 $\frac{1}{2}$ "W x 18"D x 3 $\frac{1}{2}$ "H  
(50 lbs max load)  
97504

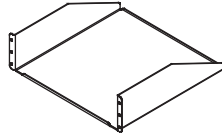

**Cantilever Shelf (3RU)**  
17 $\frac{1}{2}$ "W x 18"D x 5 $\frac{1}{4}$ "H  
(80 lbs max load)  
97502

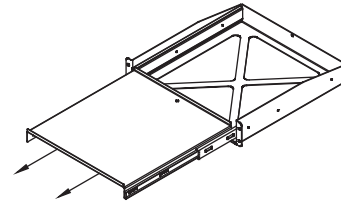

**Pull-Out Shelf (2RU)**  
16 $\frac{1}{2}$ "W x 17 $\frac{3}{4}$ "D  
(50 lbs max load)  
97505

Note: This option will not fit in the upper 3RU section of the rack rail.

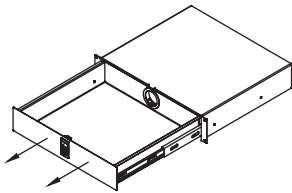

**Locking Drawer (2RU)**  
interior dims:  
15 $\frac{3}{4}$ "W x 13 $\frac{1}{16}$ "D x 2 $\frac{7}{8}$ "H  
(25 lbs max load)  
97514

Note: This option will not fit in the upper 3RU section of the rack rail.

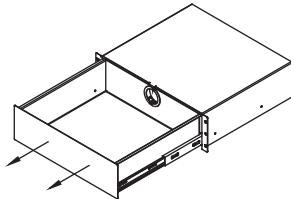

**Drawer (3RU)**  
interior dims:  
15 $\frac{15}{16}$ "W x 14 $\frac{1}{2}$ "D x 5 $\frac{1}{4}$ "H  
(50 lbs max load)  
97518

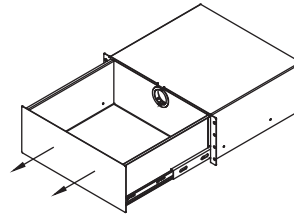

**Drawer (4RU)**  
interior dims:  
15 $\frac{15}{16}$ "W x 14 $\frac{1}{2}$ "D x 7"H  
(50 lbs max load)  
97519

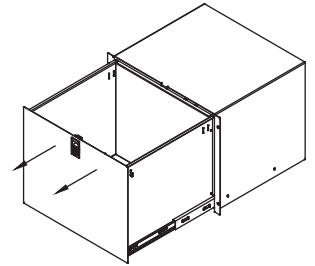

**Locking File Drawer (8RU)**  
w/ file holder  
interior dims:  
15 $\frac{3}{4}$ "W x 13 $\frac{9}{16}$ "D x 13 $\frac{5}{16}$ "H  
(50 lbs max load)  
97515

Note: This option will not fit in the upper 3RU section of the rack rail.

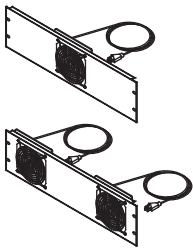

**Cooling Fans (3RU)**  
19"W x 2"D x 5 $\frac{1}{4}$ "H  
Single Fan-97507  
Double Fan-97506

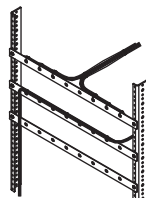

**Wire Lace Kit**  
3 lace straps included  
95517

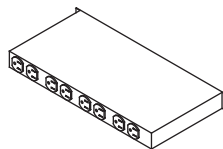

**9-Outlet Power Strip (1RU)**  
19"W x 9"D x 1 $\frac{1}{4}$ "H  
99021

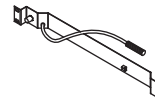

**Flexible Halogen Light (1RU)**  
19"W x 2"D x 1 $\frac{1}{4}$ "H  
99033

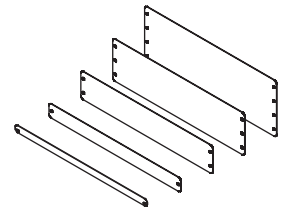

**Rack-Mount Blanks**  
(fills rack spaces where components are not needed)

97516 - (1/2 RU)  
97510 - (1RU)  
97511 - (2RU)  
97512 - (3RU)  
97513 - (4RU)

# Warranty

## WE WILL MAKE IT RIGHT FOR YOU!

Spectrum is committed to provide complete customer satisfaction. Each of our products are manufactured from the best materials available and each product is stringently monitored throughout the production process through our P.A.C.E. program (Product Assurance to meet Customer Expectations). Our Customer Service Help Line 1-800-235-1262 is ready to provide immediate attention to any questions, comments or concerns. We are available to answer your calls Monday through Friday from 7 am to 5 pm CST, excluding observed holidays. In addition your product comments or concerns are welcome via e-mail at: [spectrum@spectrumfurniture.com](mailto:spectrum@spectrumfurniture.com).

## Warranty Statement

We guarantee all Spectrum products to be free of all defects in materials and workmanship, for the original owner, for a period of ten years. Any item deemed defective by Spectrum or the original manufacturer, under normal use conditions, will be repaired or replaced at Spectrum's discretion. This warranty applies to all products manufactured and distributed by Spectrum except the products listed below.

Items that have a varying warranty include, but are not limited to, the following:

- Adjustable Crank/Electric Desk Legs (1 yr)
- Flat Panel Desk Gas Cylinders (1 yr)
- Upholstered Soft-Goods (5 yrs)
- Adjustable Height & Stacking Chair Parts – including frames, gas cylinders, wood and plastic parts, and control handles (7 yrs)
- Adjustable Height & Stacking Chair Casters (2 yrs)
- Chair Upholstery & Textiles (2 yrs of normal use of Soft Goods, Adjustable Height, Stacking, Wood and Metal Chairs)
- Chair Upholstery - Graded-In Fabrics and C.O.M (no warranty)
- Height Adjustable Columns and Lifts (1 yr)
- General Use Casters (1 yr)
- Electrical – Electri-Pak, Power Communication Modules, and special order ECA electrical items (1 yr)
- Electrical - Power Strips & Electrical Timers (1 yr)
- Electrical Surge Suppressors (lifetime)
- Electrical - Retractable Power Cords (1 yr)
- Keyboard/Mouse Trays (1 yr)
- Flat Panel Monitor Arm – General Parts (5 yrs)
- Flat Panel Monitor Arm – Gas Cylinders (2 yrs)
- CRT Monitor Arm (1 yr)

Warranty is void if product is not used for its intended purpose or subjected to an unusual application, multiple-shift use, alteration, accident, abuse or abnormal wear and tear. Representations of colors on-line and in printed materials are meant to be a close reference to the actual colors but not an exact match. Slight variations in color and texture of wood stains, powder coating, laminates, fabrics and other materials are normal in different manufacturing lots; as such these variations are not considered defects.

**DESIGNED FOR INDOOR USE ONLY** – Unless specifically stated in the product specifications, Spectrum's products have been designed and constructed for indoor use only. Moving or using outdoors, or on excessively rough surfaces, may cause damage to the products and will void the warranty. If an outdoor application is desired please contact us to discuss potential custom design solutions.

**The warranty, as stated above, supersedes any previous warranties and is effective as of 9/1/2010**



# Touchboards

205 Westwood Ave, Long Branch, NJ 07740  
Phone: 866-94 BOARDS (26273) / (732)-222-1511  
Fax: (732)-222-7088 | E-mail: [sales@touchboards.com](mailto:sales@touchboards.com)



**INDOOR AIR QUALITY**  
Indoor Advantage | Furniture

