

Evolution Teacher Instruction Center (TIC)

38941

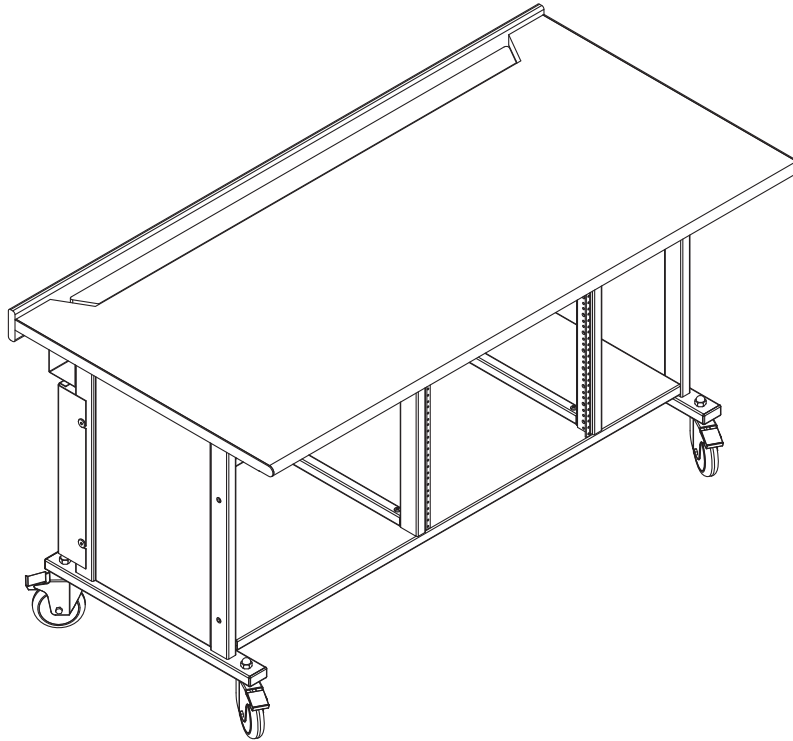

CAUTION:

Before using this product, read this manual and follow all safety and operating instructions.

Before you begin, please make sure all parts and proper quantities are included. Any parts damaged during shipment must be reported within 15 days of receipt. To report information regarding damages or if you have any questions, please call 1-800-235-1262.

To purchase parts or accessories, please contact us at
www.spectrumfurniture.com
1-800-235-1262

Thank you for purchasing Spectrum products!

Touchboards

205 Westwood Ave, Long Branch, NJ 07740

Phone: 866-94 BOARDS (26273) / (732)-222-1511

Fax: (732)-222-7088 | E-mail: sales@touchboards.com



Spectrum Industries, Inc.
Chippewa Falls, WI 54729, USA



Safety



- Read this owner's manual before assembly or operation.
- Do not allow children to move desk.
- Move slowly and carefully when mobile.
- For indoor use only. Do not install or store the unit where it will be exposed to weather. Keep unit dry.
- For added safety, plug electrical components into a grounded three-prong receptacle controlled by a GFI (Ground Fault Interrupter) circuit breaker.

Hardware Package Contents

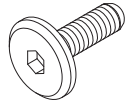

(8) 044541
1/4-20 x 20mm JC bolt



(4) 035712
4mm x 10mm PHMS



(6) 026049
screw cap



(8) 026064
1/4-20 x 5/8" PHMS

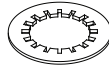

(4) 038415
Star washer

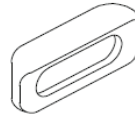

(2) 035577
oak handle

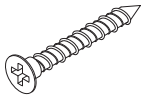

(6) 026032
#11 x 2" Hi-Lo screw



(4) 038595
1/2-13 acorn nut

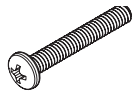

(13) 041289
1/4-20 x 1-3/4" PHMS



(4) 041943
1/4-20 locknut



(1) 025039
4mm hex wrench

Tools Required



7/16" or adjustable
wrench



Phillips
screwdriver



4mm hex wrench
(included)

Assembly / Setup

1. Attach block to worksurface

- Carefully flip the worksurface face down onto a non-abrasive surface as shown in **Figure 1**.
- Attach the support block with (1) 1/4-20 x 1-3/4" PHM Screw.

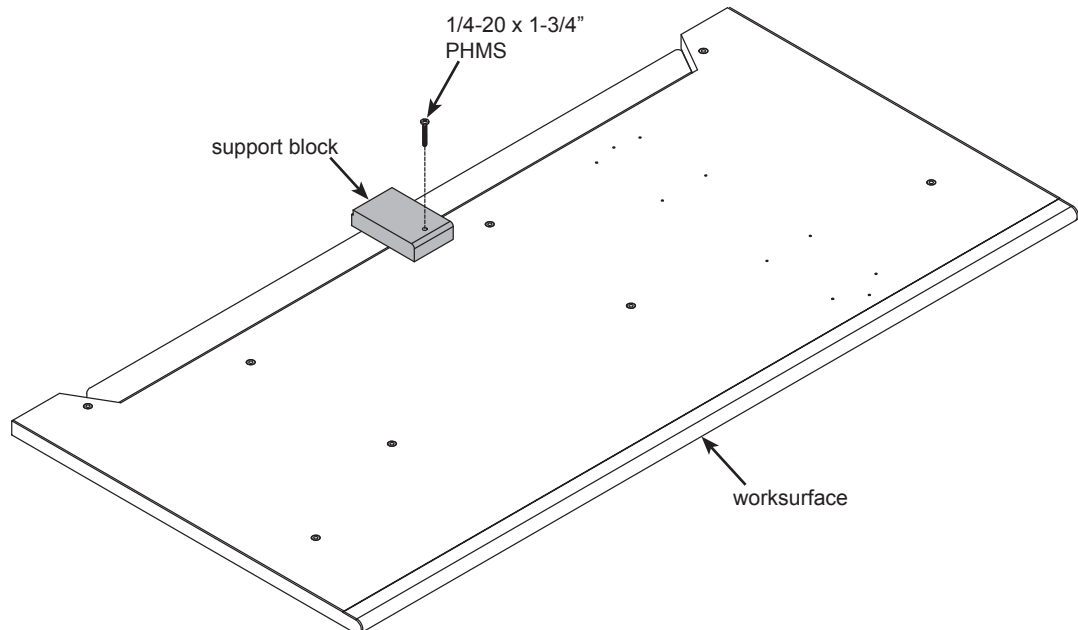

Figure 1

2. Attach legs & center supports

- A. Orient each leg with the cord channel mounting holes toward the back (flip-top side) and attach each with (2) 1/4-20 x 1-3/4" PHM screws. (Be sure the 4 leg holes and leg insert panels are facing outward.)
- B. Orient each center support with the rack rail mounting holes facing inward and attach each with (2) 1/4-20 x 1-3/4" PHM screws as shown in **Figure 2**. (*The slots on the supports will face the front of the desk.*)

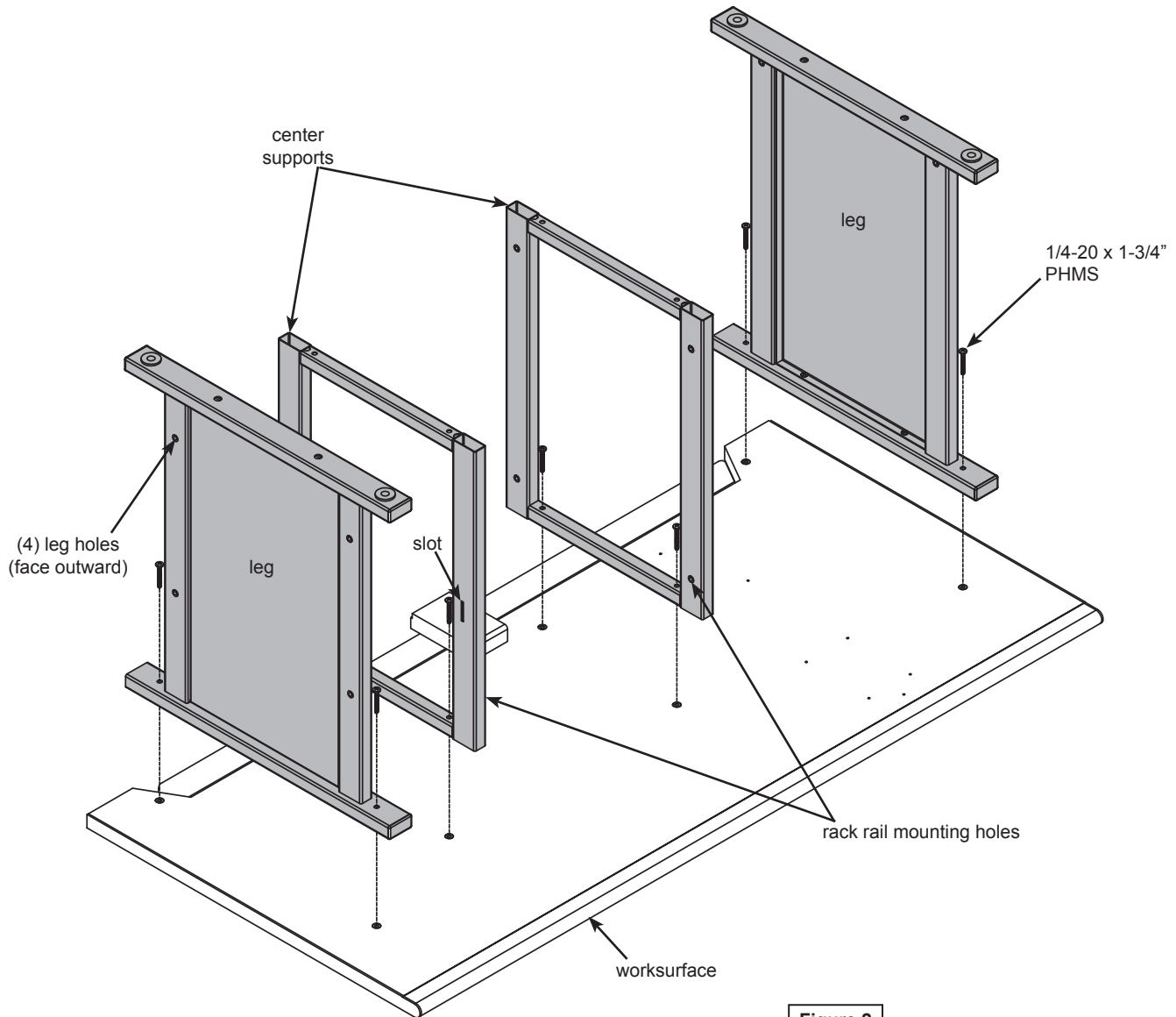

Figure 2

3. Attach cord channel & rack rail

- A. Attach the cord channel to the legs using (4) 1/4-20 x 20mm JC bolts.
- B. Orient the rack rails in the positions shown in **Figure 3** and attach each rail to a center support with (2) 1/4-20 x 5/8" PHM screws.

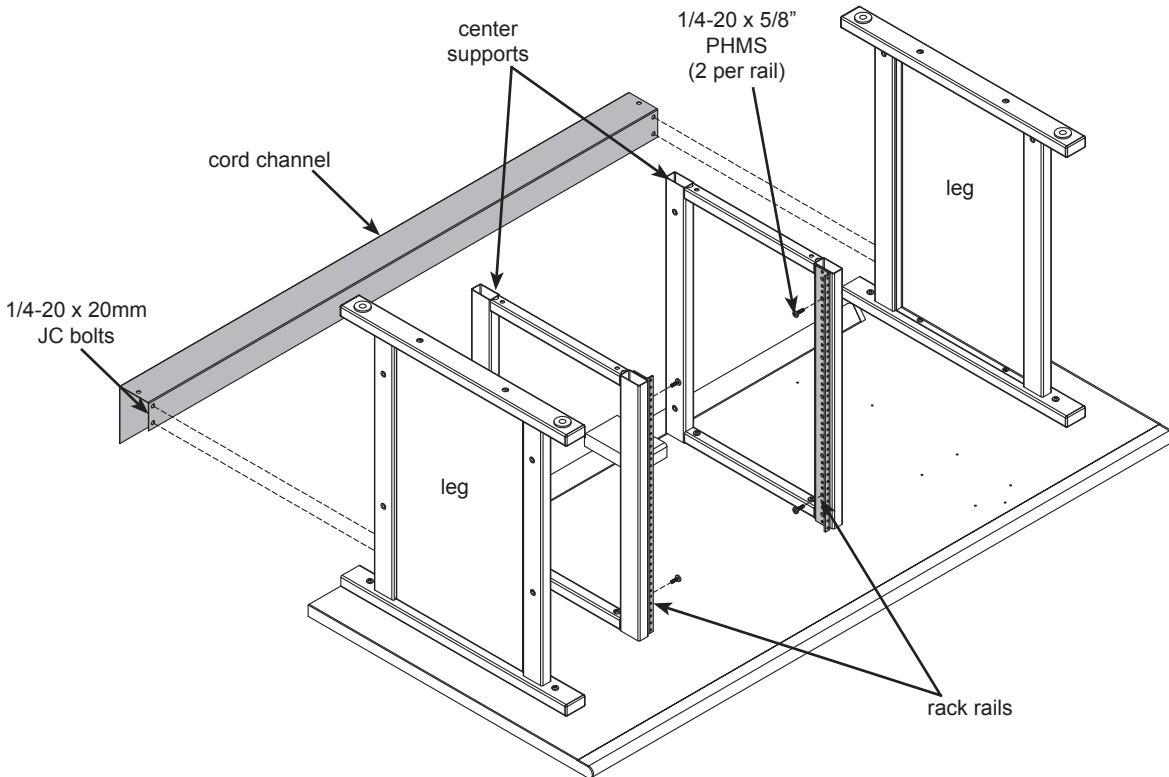

Figure 3

4. Attach bottom panel

- A. Slide the bottom panel into place as shown in **Figure 4A** and align mounting holes.
- B. Attach panel to legs with (4) 1/4-20 x 5/8" PHM screws. **Figure 4B**.
- C. Using (4) 1/4-20 x 1-3/4" PHM screws and (4) 1/4-20 locknuts, attach the bottom panel to the center supports. (The screws will install from inside the desk and the nuts will thread on from the bottom.)

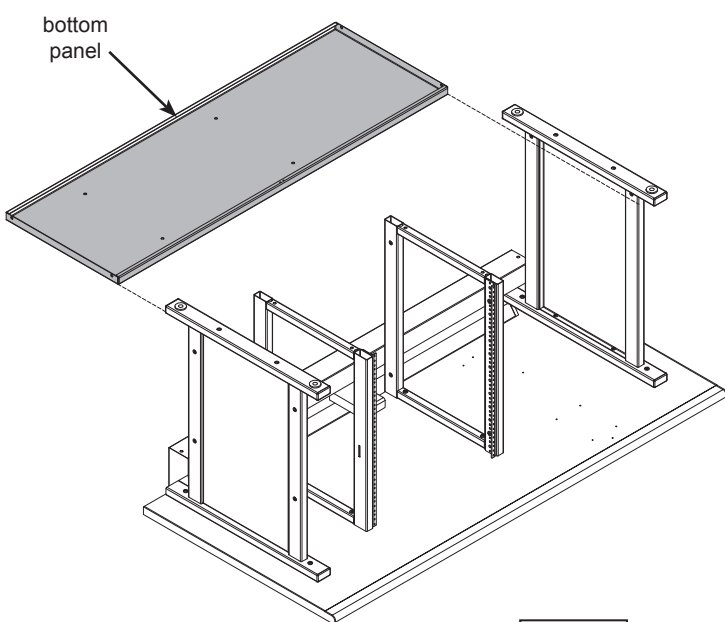

Figure 4A

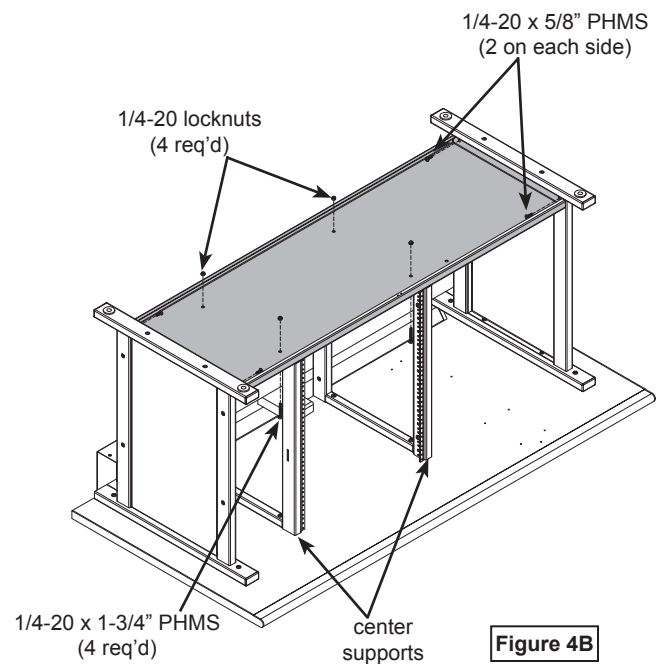

Figure 4B

5. Attach casters / wheels

- Thread each caster/wheel stem into the leg and tighten securely with an adjustable wrench.
- Place a star washer onto the stem on the opposite side of the leg and thread a 1/2-13 acorn nut over each washer. **Figure 5.**
- Tighten acorn nut securely with a 3/4" or adjustable wrench.

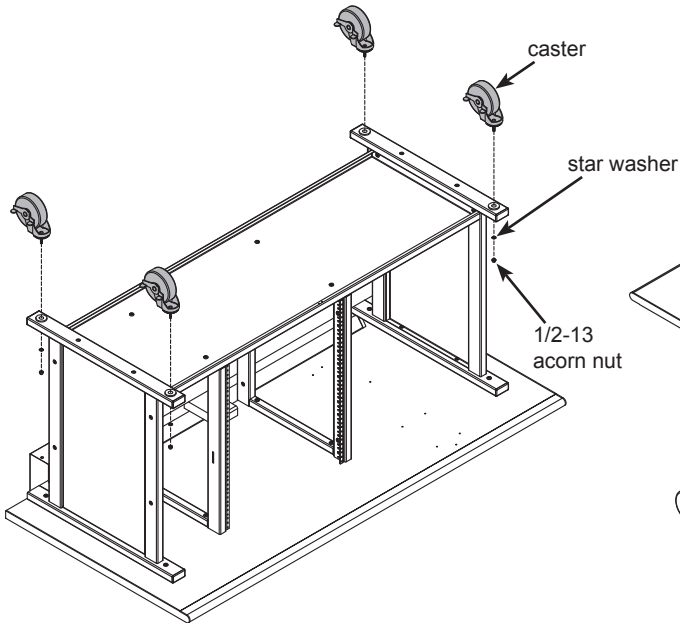

Figure 5

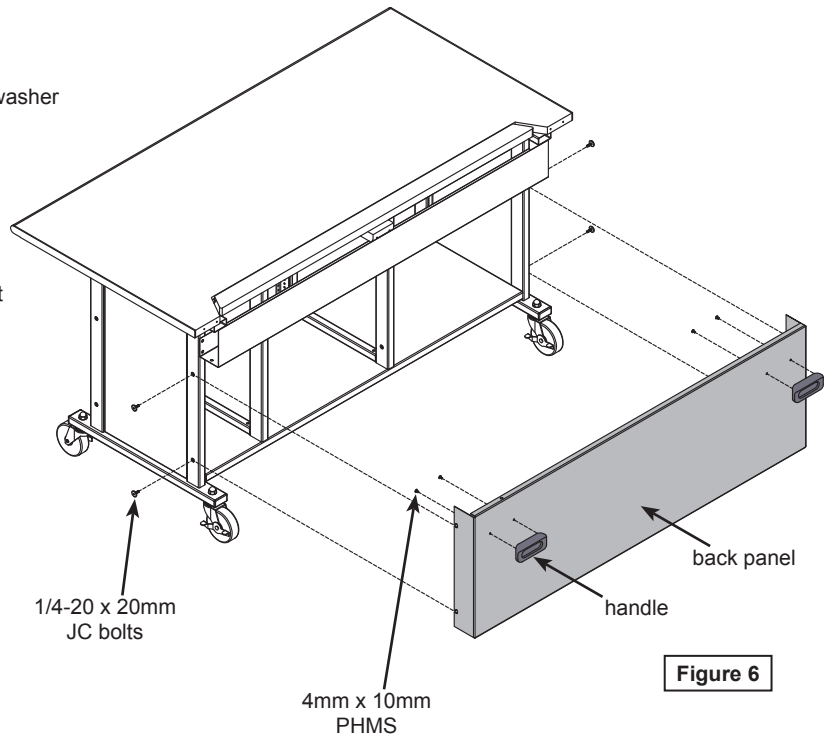

Figure 6

6. Attach handles & back panel

- Carefully flip the desk upright. This will require two people.
- Thread in (4) 1/4-20 x 20mm JC bolts into the side of the back legs as shown in **Figure 6**, but do not tighten completely-the back panel will lock onto these bolts.
- Attach each handle to the back panel as shown with (2) 4mm x 10mm PHM screws and tighten securely.
- Align the back panel notches with The JC bolts and install the panel into place. (It may be necessary to loosen the JC bolts slightly to fit the panel correctly.)
- Tighten the JC bolts securely.

7. Attach chair rail

- Attach the chair rail to the desk as shown in **Figure 7** with (6) #11 x 2" hi-lo screws and tighten securely.
- Snap the screw caps onto the screw heads.

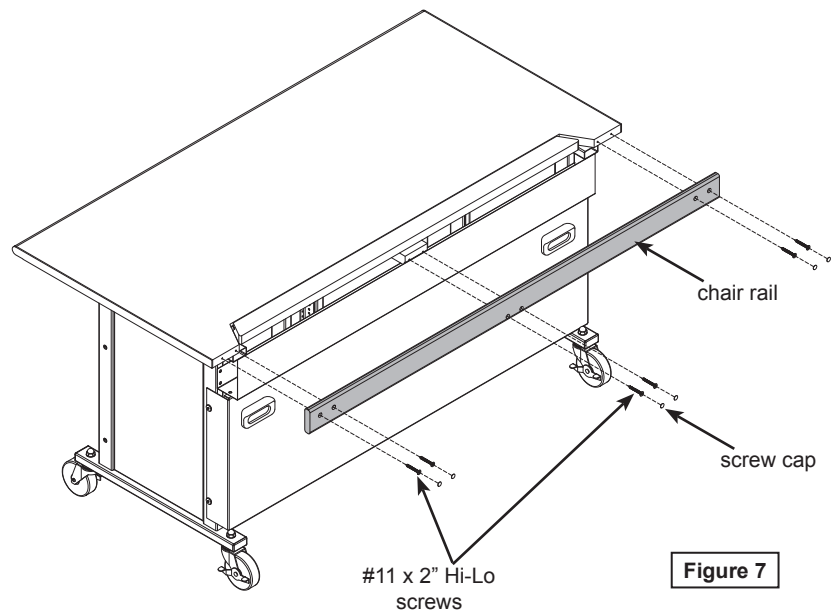

Figure 7

Moving the desk

- Before moving the unit, unplug all power cords.
- Be sure the casters are in the unlocked position and doors closed (if equipped).
- Move the desk slowly and carefully.
- Lock the casters after moving.



**WARNING
ATTENTION**



CAN TIP OVER RESULTING IN RISK OF INJURY, DO NOT ALLOW CHILDREN UNDER 16 TO MOVE CART. MOVE CART SLOWLY.

PEUT BASCULER, ENTRAINANT UN RISQUE DE BLESSURE, NE LAISSEZ PAS LES ENFANTS DO MOINS DE 16 POUR DEPLACER PANIER. DEPLACER PANIER LENTEMENT

ONLY ADULTS SHOULD MOVE THIS UNIT

SEULS LES ADULTES DEVRAIENT PASSER CET APPAREIL

APPLY MOVING FORCE ON NARROW DIMENSION

APPLIQUER UNE FORCE EN MOUVEMENT SUR LA DIMENSION

NEVER APPLY FORCE AT TOP ALWAYS PUSH NEAR MIDDLE

JAMAIS EMPLOYER LA FORCE EN HAUT TOUJOURS POUSSER PRES DU MILIEU

PUSH, DO NOT PULL

POUSSER, NE TIREZ PAS

Options

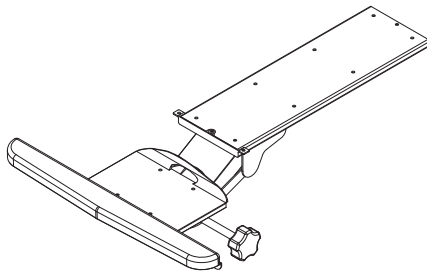

Econo Keyboard Tray
18 $\frac{3}{8}$ "W x 12"D
95520

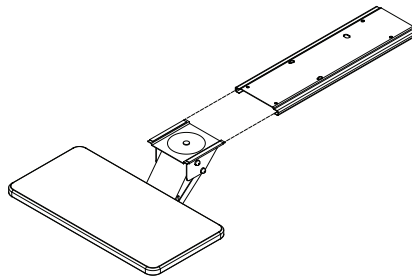

Micro-Arm Keyboard Tray
moves in, out, up & down
19 $\frac{1}{4}$ "W x 10"D
95506

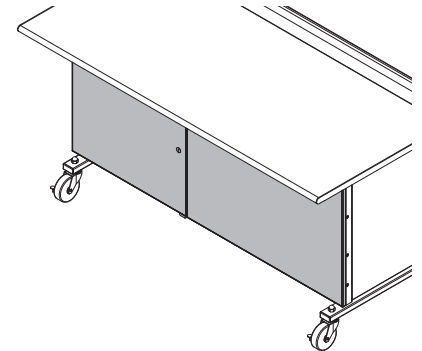

Locking Front Door Kit
38944

Note: Not compatible with optional keyboard trays.

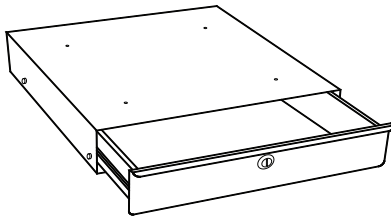

Universal Laptop Drawer
16"W x 17 $\frac{1}{2}$ "D x 3 $\frac{1}{2}$ "H
95510



7-Outlet Power Strip, insured w/ surge protector, and 15' cord
12"W x 2"D x 1 $\frac{5}{16}$ "H
99024

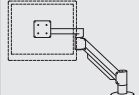

Flat Panel Monitor Arms & Tablet Mounts
(See the Spectrum website or catalog for the latest available monitor arm & tablet mounting options)

Rack-mount accessories

Note: Rack-mount accessories with a depth greater than 18 $\frac{3}{4}$ "D will not fit in the TIC. Check the dimensions of all equipment before installation. The following Spectrum rack-mount accessories will not fit the TIC:

97517 - LT-4 Laptop Storage Unit
97503 - Pull-out Shelf (3RU)

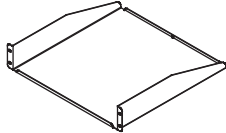

Cantilever Shelf (2RU)
17 $\frac{1}{2}$ "W x 18"D x 3 $\frac{1}{2}$ "H
(50 lbs max load)
97504

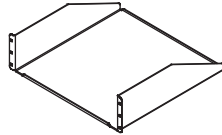

Cantilever Shelf (3RU)
17 $\frac{1}{2}$ "W x 18"D x 5 $\frac{1}{4}$ "H
(80 lbs max load)
97502

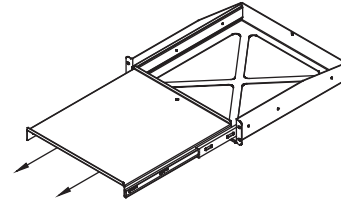

Pull-Out Shelf (2RU)
16 $\frac{1}{2}$ "W x 17 $\frac{3}{4}$ "D
(50 lbs max load)
97505

Note: This option will not fit in the upper 3RU section of the rack rail.

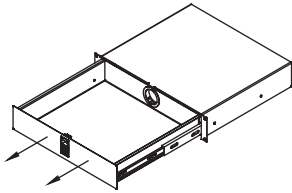

Locking Drawer (2RU)
interior dims:
15 $\frac{3}{4}$ "W x 13 $\frac{1}{16}$ "D x 2 $\frac{7}{8}$ "H
(25 lbs max load)
97514

Note: This option will not fit in the upper 3RU section of the rack rail.

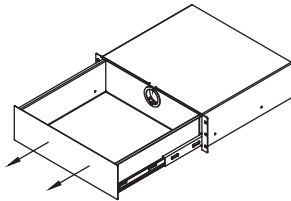

Drawer (3RU)
interior dims:
15 $\frac{15}{16}$ "W x 14 $\frac{1}{2}$ "D x 5 $\frac{1}{4}$ "H
(50 lbs max load)
97518

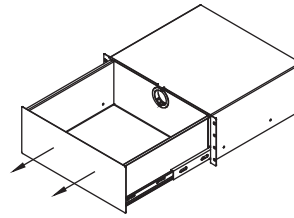

Drawer (4RU)
interior dims:
15 $\frac{15}{16}$ "W x 14 $\frac{1}{2}$ "D x 7"H
(50 lbs max load)
97519

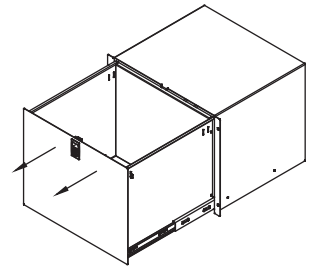

Locking File Drawer (8RU)
w/ file holder
interior dims:
15 $\frac{3}{4}$ "W x 13 $\frac{3}{16}$ "D x 13 $\frac{3}{16}$ "H
(50 lbs max load)
97515

Note: This option will not fit in the upper 3RU section of the rack rail.

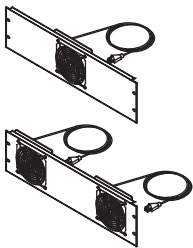

Cooling Fans (3RU)
19"W x 2"D x 5 $\frac{1}{4}$ "H
Single Fan-97507
Double Fan-97506

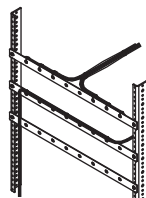

Wire Lace Kit
3 lace straps included
95517

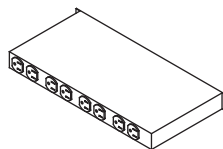

9-Outlet Power Strip (1RU)
19"W x 9"D x 1 $\frac{3}{4}$ "H
99021

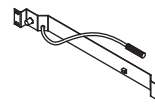

Flexible Halogen Light (1RU)
19"W x 2"D x 1 $\frac{3}{4}$ "H
99033

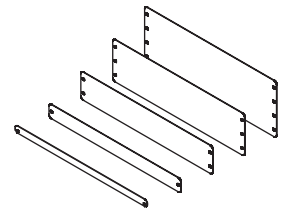

Rack-Mount Blanks
(fills rack spaces where components are not needed)

97516 - (1/2 RU)
97510 - (1RU)
97511 - (2RU)
97512 - (3RU)
97513 - (4RU)

Warranty

WE WILL MAKE IT RIGHT FOR YOU!

Spectrum is committed to provide complete customer satisfaction. Each of our products are manufactured from the best materials available and each product is stringently monitored throughout the production process through our P.A.C.E. program (Product Assurance to meet Customer Expectations). Our Customer Service Help Line 1-800-235-1262 is ready to provide immediate attention to any questions, comments or concerns. We are available to answer your calls Monday through Friday from 7 am to 5 pm CST, excluding observed holidays. In addition your product comments or concerns are welcome via e-mail at: spectrum@spectrumfurniture.com.

Warranty Statement

We guarantee all Spectrum products to be free of all defects in materials and workmanship, for the original owner, for a period of ten years. Any item deemed defective by Spectrum or the original manufacturer, under normal use conditions, will be repaired or replaced at Spectrum's discretion. This warranty applies to all products manufactured and distributed by Spectrum except the products listed below.

Items that have a varying warranty include, but are not limited to, the following:

- Adjustable Crank/Electric Desk Legs (1 yr)
- Flat Panel Desk Gas Cylinders (1 yr)
- Upholstered Soft-Goods (5 yrs)
- Adjustable Height & Stacking Chair Parts – including frames, gas cylinders, wood and plastic parts, and control handles (7 yrs)
- Adjustable Height & Stacking Chair Casters (2 yrs)
- Chair Upholstery & Textiles (2 yrs of normal use of Soft Goods, Adjustable Height, Stacking, Wood and Metal Chairs)
- Chair Upholstery - Graded-In Fabrics and C.O.M (no warranty)
- Height Adjustable Columns and Lifts (1 yr)
- General Use Casters (1 yr)
- Electrical – Electri-Pak, Power Communication Modules, and special order ECA electrical items (1 yr)
- Electrical - Power Strips & Electrical Timers (1 yr)
- Electrical Surge Suppressors (lifetime)
- Electrical - Retractable Power Cords (1 yr)
- Keyboard/Mouse Trays (1 yr)
- Flat Panel Monitor Arm – General Parts (5 yrs)
- Flat Panel Monitor Arm – Gas Cylinders (2 yrs)
- CRT Monitor Arm (1 yr)

Warranty is void if product is not used for its intended purpose or subjected to an unusual application, multiple-shift use, alteration, accident, abuse or abnormal wear and tear. Representations of colors on-line and in printed materials are meant to be a close reference to the actual colors but not an exact match. Slight variations in color and texture of wood stains, powder coating, laminates, fabrics and other materials are normal in different manufacturing lots; as such these variations are not considered defects.

DESIGNED FOR INDOOR USE ONLY – Unless specifically stated in the product specifications, Spectrum's products have been designed and constructed for indoor use only. Moving or using outdoors, or on excessively rough surfaces, may cause damage to the products and will void the warranty. If an outdoor application is desired please contact us to discuss potential custom design solutions.

The warranty, as stated above, supersedes any previous warranties and is effective as of 9/1/2010

Touchboards

205 Westwood Ave, Long Branch, NJ 07740
Phone: 866-94 BOARDS (26273) / (732)-222-1511
Fax: (732)-222-7088 | E-mail: sales@touchboards.com

