

# Fieldpiece®

## SMAN® Refrigerant Manifold with Built-in Vacuum Gauge OPERATOR'S MANUAL

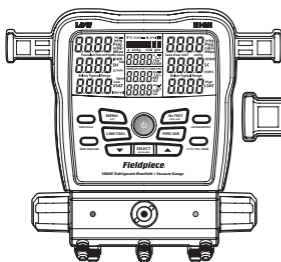

3 Port  
Model SM382V

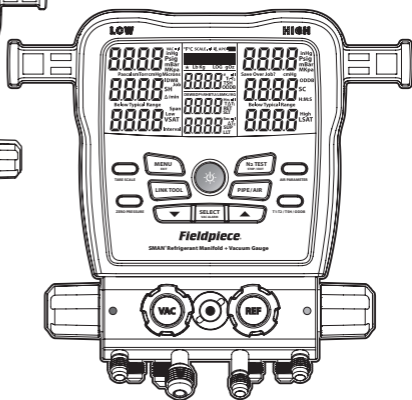

4 Port  
Model SM482V

# Contents

## **Important Notice** . . . . . 4

Class A2L/A2/A3 Refrigerant Safety Notice  
Warnings

## **Quick Start** . . . . . 5

What's Included

## **Description** . . . . . 6

Features

SM382V Front View

SM382V Rear View

SM482V Front View

SM482V Rear View

Display

## **Operation** . . . . . 18

Buttons

Recent Refrigerants

LINK TOOL Select

N2 TEST Select (Pressure Test)

PIPE / AIR Select

T1-T2 / TSH / ODDB Select

Superheat (SH) and Subcooling (SC)

Target Superheat (TSH)

Deep Vacuum (SM382V & SM482V)

Test for Non-Condensables

## **Menu** . . . . . 29

Data Logging

Auto Power Off (APO)

Temperature Calibration (CalTemp)

ToolSet

Units

Vacuum Alarms

Backlight Timer

Advanced Pressure Calibration

Firmware View and Update

Restore User Settings

Delete Log File

Format Internal Flash Drive

## **Maintenance** . . . . . 40

Cleaning

Battery Replacement

Using Different Refrigerants

Spare Parts

Hose Holder Replacement

Pipe Clamp Storage Arm Replacement

Valve and Knob Replacement

## **Specifications** . . . . . 44

Temperature

Pressure

Deep Vacuum

Wireless Compatibility

Manifold Diagrams (SM382V & SM482V)

## **Certification and Module IDs** . . . . . 47

## **Limited Warranty** . . . . . 50

# Important Notice

This is not a consumer product. Only qualified personnel trained in service and installation of A/C and/or refrigeration equipment shall use this product.

Read and understand this operator's manual in its entirety before using your SMAN® Refrigerant Manifold to prevent injury or damage to you or equipment.

## Class A2L/A2/A3 Refrigerant

### Safety Notice

Systems using class A2L (mildly flammable), class A2 (flammable), or class A3 (highly flammable) refrigerants can be tested safely ONLY by qualified personnel explicitly trained in the use and handling of those refrigerants. This manual is in no way a replacement for proper training.

#### **WARNINGS**

- Do not apply more than 870 psig to any port of the manifold.
- Ground properly when testing A2L/A2/A3 (hydrocarbon) refrigerants.
- Do not use in the vicinity of explosive substances.
- Inhalation of high concentrations of refrigerant vapor can block oxygen to the brain causing injury or death.
- Refrigerant liquid can cause frostbite.
- Follow all equipment manufacturer's testing procedures above those in this manual in regards to properly servicing their equipment.

# Quick Start

1. Install the included six AA batteries into rear battery compartment.
2. Press center blue button for 2 seconds to turn on your new SMAN® manifold.
3. Connect your hoses and pipe clamps to the SMAN® manifold and to the system.
4. View live pressures and temperatures.
5. Use arrow buttons to cycle through available refrigerants and view calculations in real-time!

## What's Included

- SMAN® Refrigerant Manifold (3 Port), or
- SMAN® Refrigerant Manifold (4 Port)
- (1) ANC82 Padded, Easy-Open Case
- (2) TC24 Type K Pipe Clamp Thermocouples
- (1) ATA1 Type K Bead Thermocouple w/Clip
- (6) AA Alkaline Batteries
- (1) Year Warranty
- Operator's Manual

## Scan for more languages.



US, CA, MX



EN, DE, FR, IT, ES, PT,  
NL, SE, DK, FI

# Description

SMAN® Refrigerant Manifolds give you the trust needed for doing the job right the first time.

Your new Fieldpiece manifold has the protection and long range wireless communication demanded by professionals working in the field. The impact resistant housing seals and protects from dust, bumps, and rain. Use the heavy duty hook to hang it in your work vehicle while protected by its easy-open padded soft case.

SMAN® is your testing hub at the jobsite. In addition to the included thermocouples, you can connect wirelessly to psychrometers, pipe clamps, and even a refrigerant scale. For example, assign one psychrometer (model JL3RH) to return air and another to supply air to view live temperature split across the evaporator.

View it all clearly, in any lighting condition, on the extra large LCD or remotely on your mobile device. A rolling list of your 10 most recently used refrigerants, indicated by a ★, is stored at the top of the main refrigerant list for quick selection.

Verify proper charge by comparing actual superheat (SH) with target superheat (TSH). A thermocouple is included for wired outdoor dry bulb. You can link optional wireless tools for live indoor wet bulb and outdoor dry bulb!

Pressure sensors automatically compensate for altitude and weather changes. Use the internal vacuum gauge for fast and convenient monitoring of your evacuations, or link to a wireless vacuum gauge for more control.

## Features

### Job Link® System

- Long Wireless Range (1000 feet / 305 meters)
- Connect to Your Mobile Device (page 43)
- Connect Job Link Tools (page 43)

### Real-time Calculations

- Superheat and Subcooling
- Vapor Saturation and Liquid Saturation
- Target Superheat (requires model JL3RH for real-time)
- T1-T2

### (3) Type K Thermocouple Jacks

- Suction Line
- Liquid Line
- Outdoor Ambient

### Robust Port Design

- SM382V: (3) 1/4"
- SM482V: (3) 1/4" + (1) 3/8"

### Built-in Vacuum Gauge with Graphic Indicators

### Nitrogen Test (Tightness Test)

### Recent Refrigerant List

### Sealed Sight Glass

### Heavy Duty Rubberized Construction

### Rugged Hanging Hook

### Operation in the Rain (IP55)

### Data Logging with USB-C Export

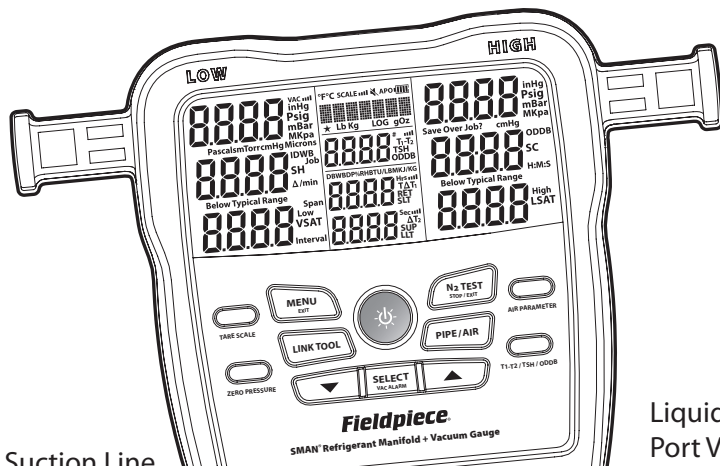

Pipe Clamp  
Storage Arms

## SM382V Front View

Liquid Line  
Port Valve

Suction Line  
Port Valve

Suction  
Line Port

Refrigerant Port  
Connect to a refrigerant cylinder  
directly, to a recovery machine,  
or to a vacuum pump.

Sight  
Glass

Liquid  
Line Port

Fieldpiece Vacuum Pumps  
available in 6 CFM, 8 CFM  
& 10 CFM models  
(sold separately)

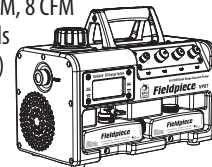

Fieldpiece Recovery  
Machine model MR45  
(sold separately)



**NOTE:** Use the front ports as Hose Holders  
and back ports as Manifold ports.

# SM382V Rear View

**(LLT) Pipe Clamp Storage Arm**

**(SLT) Pipe Clamp Storage Arm**

Battery Cover Screws

Steel Hanging Hook

Battery Door Finger Pull

4 Digit Job Link® System ID  
Use when connecting to the Job Link Mobile App for testing and reporting

USB-C Port  
Access with removable rubber cover. Ensure it is on to maintain IP-55 water resistant rating.

**(LLT) Liquid Line Thermocouple Jack**  
Shown not inserted enough past the bumpers

**(ODDB) Outdoor Thermocouple Jack**  
Shown without thermocouple

**(SLT) Suction Line Thermocouple Jack**  
Shown fully inserted & locked into the bumpers

**Thermocouple Bumpers**  
Bumpers help secure thermocouple plugs. Pipe clamp thermocouples have indents on the plug that line up with the bumper when fully inserted.

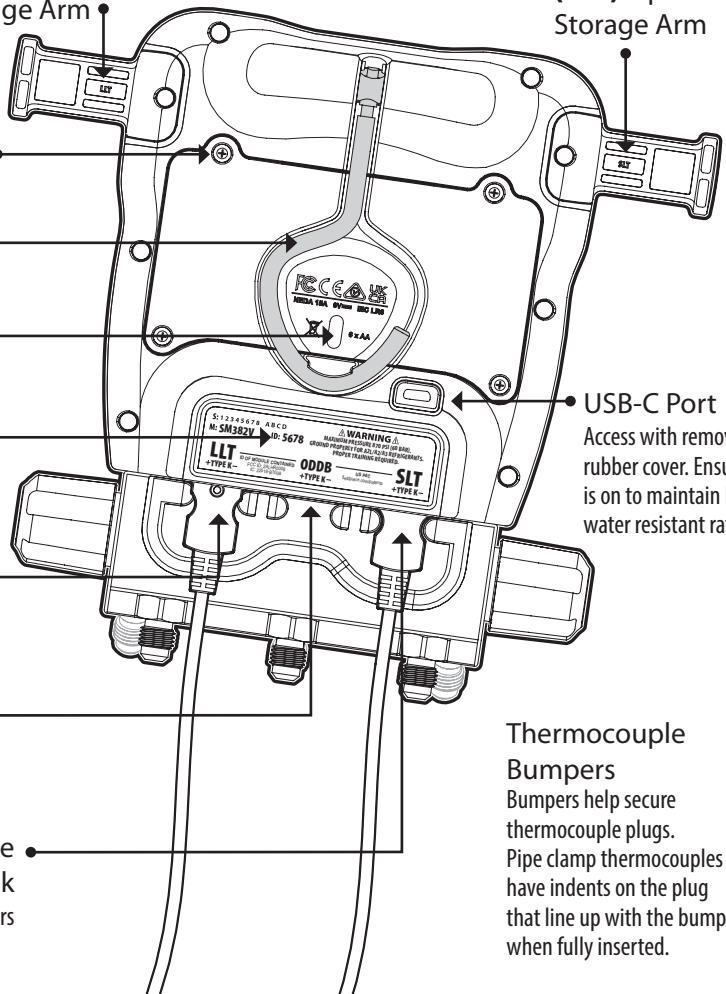

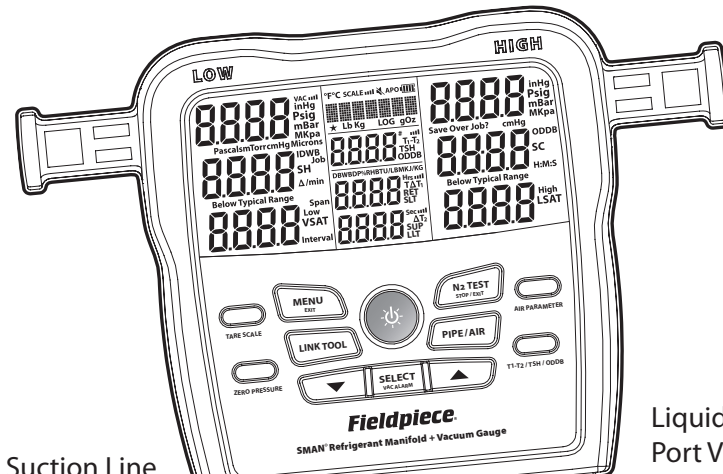

Pipe Clamp  
Storage Arms

## SM482V Front View

**NOTE:** Use the front ports as Hose Holders and back ports as Manifold ports.

Suction Line  
Port Valve

Liquid Line  
Port Valve

Vacuum  
Port Valve

Refrigerant Port Valve

Suction  
Line Port

Liquid  
Line Port

Sight  
Glass

Refrigerant Port  
Connect to a refrigerant  
cylinder directly, or to  
a recovery machine like  
Fieldpiece model MR45

Vacuum Port  
Large port matches perfectly with  
Fieldpiece Vacuum Pumps

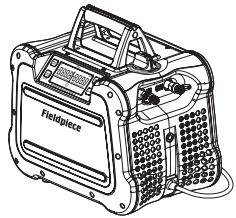
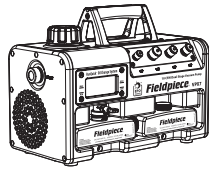

# SM482V Rear View

**(LLT) Pipe Clamp  
Storage Arm**

**(SLT) Pipe Clamp  
Storage Arm**

Battery Cover Screws

Steel Hanging Hook

Battery Door Finger Pull

4 Digit Job Link® System ID

Use when connecting to the Job Link Mobile App for testing and reporting

USB-C Port

Access with removable rubber cover. Ensure it is on to maintain IP-55 water resistant rating.

**(LLT) Liquid Line  
Thermocouple Jack**

Shown not inserted enough past the bumpers

**(ODDB) Outdoor**

Thermocouple Jack  
Shown without thermocouple

**(SLT) Suction Line**

Thermocouple Jack

Shown fully inserted & locked into the bumpers

**Thermocouple  
Bumpers**

Bumpers help secure thermocouple plugs. Pipe clamp thermocouples have indents on the plug that line up with the bumper when fully inserted.

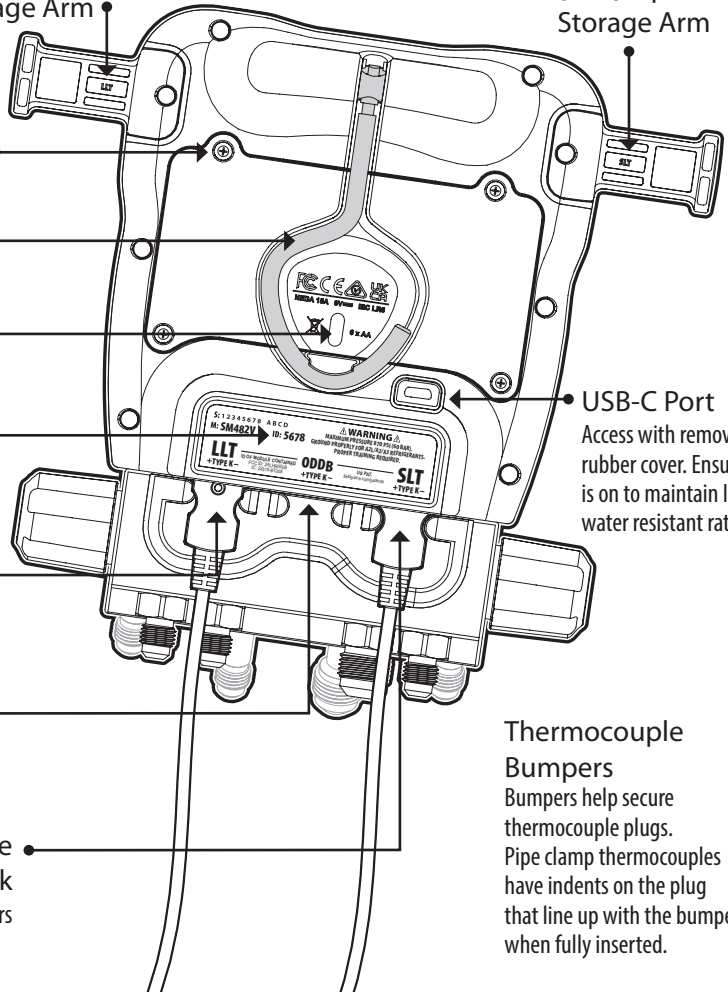



# Display

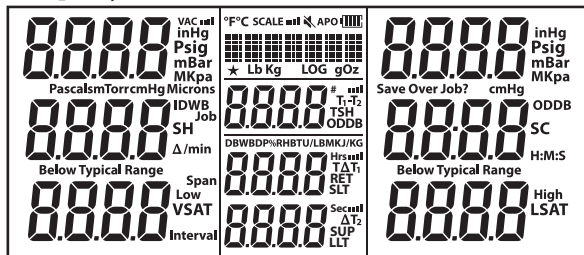

°F: Temperature (Fahrenheit)

°C: Temperature (Celsius)

**Psig:** Pressure (pounds/in<sup>2</sup>)

**Bar:** Pressure / Negative Pressure

**MPa:** Pressure (megapascals)

**kPa:** Pressure (kilopascals)

**inHg:** Negative Pressure (inches of mercury)

**cmHg:** Negative Pressure (centimeters of mercury)

**Microns:** Vacuum (microns of mercury)

**Pascals:** Vacuum

**mBar:** Vacuum (millibar)

**mTorr:** Vacuum (millitorr)

**Torr:** Vacuum (equivalent to mmHg)

**Δ/min:** Vacuum Rate (differential per minute)

**H:M:S:** Hours:Minutes or Minutes:Seconds

**SH:** Superheat (suction line - vapor saturation)

**SC:** Subcooling (liquid saturation - liquid line)

**VSAT:** Vapor Saturation Temperature (from P-T chart)

**LSAT:** Liquid Saturation Temperature (from P-T chart)

**TSH:** Target Superheat (calculated from IDWB and ODDB)

**T1-T2:** Measurement Differential

**SLT:** Suction Line Temperature (low side)

**LLT:** Liquid Line Temperature (high side)

**ODDB:** Outdoor Dry Bulb Temperature

**IDWB:** Indoor Wet Bulb Temperature

**LOG:** Data Logging in Progress

**Job:** Job Slot (1-9) of Data Log

**Span:** Hours (Hrs) of Data Logging

**Interval:** Seconds (Sec) Between Logged Measurements

**Low:** Vac Alarm Lowest Micron Level

**High:** Vac Alarm Highest Micron Level

**RET:** Return Psychrometer

**SUP:** Supply Psychrometer

**DB:** Dry Bulb from Psychrometer

**WB:** Wet Bulb from Psychrometer

**DP:** Dew Point from Psychrometer

**%RH:** Relative Humidity from Psychrometer

**BTU/LBM:** Enthalpy from Psychrometer (BTU per pound mass)

**KJ/KG:** Enthalpy from Psychrometer (kilojoules per kilogram)

**TAT:** Target Dry Bulb Split from Psychrometers (Target Delta T)

**ΔT:** Dry Bulb Split from Psychrometers (Delta T)

**Lb:** Pounds (from wireless scale)

**Oz:** Ounces (from wireless scale)

**Kg:** Kilograms (from wireless scale)

**g:** Grams (from wireless scale)

**VAC:** Wireless Vacuum Gauge Connected

**SCALE:** Wireless Scale Connected

**APO:** Auto Power Off Enabled

★ : Top 10 Refrigerant Selected

🔊 : Speaker Turned Off

🔋 : Battery Life Remaining



📶 : Wireless Signal Strength

# Operation

## Buttons

A beep sounds when a button is pressed. A double beep sounds when a button is pressed and the function is not possible at that time. The speaker can be muted altogether (page 29).

 Press 2 sec to toggle power. Press to toggle backlight.

  Cycle through refrigerants, change values or vacuum views.

**SELECT:** Confirm a changed value or activate a VAC ALARM (page 24).

**MENU:** Enter the menu (page 29) or EXIT a mode.

**LINK TOOL:** Connect wireless tools (page 19).

**N<sub>2</sub> TEST:** For Nitrogen pressure tests (page 20).

**PIPE / AIR:** Display SLT/LLT or various return and supply air measurements from optional psychrometers (page 21).

**TARE SCALE:** Press 2 sec to zero (tare) weight from a wireless scale.

**ZERO PRESSURE:** Press 2 sec to zero the displayed pressures.

**AIR PARAMETER:** Toggle to display DB, WB, DP, %RH, BTU/LBM, TΔT & ΔT (page 23).

**T1-T2/TSH/ODDB:** Display T1-T2, TSH, or ODDB (page 21).

## Recent Refrigerants (★)

A rolling list of your 10 most recent refrigerants, indicated by a ★, is stored above the main list. When you power off your manifold, the current refrigerant is added automatically to this dynamic list of 10.

## LINK TOOL

Assign wireless Job Link® System tools to core manifold measurements such as pipe temperature or to broader measurements such as refrigerant weights and psychrometrics.

1. Press **LINK TOOL** to search for supported Fieldpiece wireless tools.
2. Turn on any wireless sources you want to assign.

*If your Job Link® System tool has a selector switch, ensure it's set to match the measurement.*

3. Use **ARROWS** to auto search yes or no.  
*Job Link® System tools are displayed by their 4 digit ID, usually found on the back of the tool.*
4. Press **SELECT** to select and return to the list of measurements.

- Press **MENU** to exit at any time. *If changes were made, choose whether or not you want to save changes.*
- Most Job Link® System tools have a switch that selects a side of the system. Set it to match the measurement you're assigning it to.
- A wireless Return psychrometer is assigned to both Return air and IDWB (page 23) when selected.

NOTE: When adding JL3PC or JL3LC pipe clamps, you will need to disconnect the TC24 Type-K pipe clamps from the manifold.

## N2 TEST (Pressure Test)

After working on a refrigerant-side component of an emptied system, it's a good idea to pressurize the system with dry nitrogen and check for pressure drops before evacuation.

1. Pressurize the system with dry nitrogen. *Pressure levels vary with the equipment you're testing. Always check with the manufacturer.*
  2. Connect the low side (suction line) port to the system and wait for the pressure to stabilize. *You can connect the high side (liquid line) as well to help monitor stability, but the pressure differential (P.dIF) calculation is only using the low side sensor.*
  3. Attach SLT clamp to the pipe you're going to pressurize. *This temperature is used to compensate for any temperature changes between the start and end of the test. Select "Comp. OFF" in MENU to deactivate temperature compensation.*
  4. Press **N2 TEST** to prepare test.
  5. Press **N2 TEST** to start the test. *The stopwatch starts. Real-time compensated pressure change is labeled  $\Delta$ . Real-time temperature is labeled SLT. Real-time temperature change is labeled  $\Delta T$ .*
  6. Press **N2 TEST** to stop the test. *The stopwatch,  $\Delta$ , and  $\Delta T$  freeze. If  $\Delta$  is negative, there may be a leak in the system. If  $\Delta$  is positive, SLT or nitrogen temperature may be unstable. High and low side pressures and SLT continue to display, but they are no longer being used.*
  7. Press **N2 TEST** to exit the test.
- To save battery life, the screen will turn off after 3 hours of testing, but will continue to test. Press any button to turn the screen on.

## PIPE / AIR

Press **PIPE / AIR** to display various calculations and measurements from Job Link® System psychrometers you've assigned (page 19). The parameter is briefly shown when pressed, then shown at the top of the LCD.

Press **PIPE / AIR** for >1 second to view SLT/LLT.

**SLT:** Live reading of suction line temperature.

**LLT:** Live reading of liquid line temperature.

**RET:** Live reading from return air psychrometer.

**SUP:** Live reading from supply air psychrometer.

**TΔT:** Live target dry bulb split from psychrometers.

**ΔT:** Live actual dry bulb split from psychrometers.

## T1-T2 / TSH / ODDB

Press **T1-T2 / TSH / ODDB** to cycle through ODDB (outdoor dry bulb), TSH (target superheat), and T1-T2 (middle display - bottom display).

**ODDB:** Live reading of the rear ODDB thermocouple jack. ODDB does not show if set to manual value (page 23).

**TSH:** Live target superheat calculated from ODDB and IDWB. Each of these measurements can be live or manually entered (page 21).

**T1-T2:** Live simple subtraction of the bottom display (T2) from the middle display (T1). *With SLT and LLT showing, you can check for a temperature drop across a filter drier. With RET and SUP showing, you can check the effect of the indoor unit. With TΔT and ΔT showing, you can see how close the actual ΔT is to the target.*

## Superheat (SH) and Subcooling (SC)

Superheat is the amount of heat added to refrigerant after changing to a vapor in the evaporator. Subcooling is the amount of heat removed from refrigerant after changing to a liquid in the condenser. View both live at the same time!

1. Use **ARROWS** to select the system refrigerant.
  2. Close all manifold valves.
  3. Connect EPA approved refrigerant hoses to LOW and HIGH side ports.
  4. Connect your supported wireless pipe clamps, or fully plug pipe clamp thermocouples into SLT and LLT rear jacks. See LINK TOOL on page 19.
  5. Hand tighten both the LOW side hose to suction line service port and the HIGH side hose to the liquid line service port.
  6. Clamp the SLT thermocouple to the suction line between the evaporator and compressor, at least 6 inches from the compressor.
  7. Clamp the LLT thermocouple to the liquid line between the condenser and metering device, as close to the service port as possible.
  8. Purge hoses as you open HIGH and LOW manifold valves.
  9. View superheat and subcooling in real-time.
- Ensure system has stabilized before using superheat or subcooling to adjust the charge of the system.
  - To add or remove refrigerant connect the tank/cylinder/machine to the REF port. Use the manifold valves to precisely charge or recover refrigerant as needed. Follow recommended charging or recovery practices from equipment manufacturer and training.
  - When superheat and/or subcooling cannot be calculated, “- - - -” will be displayed. If superheat and/or subcooling is negative, “Below Typical Range” will show. In rare cases this is normal, but usually a thermocouple is disconnected or the selected refrigerant is incorrect.

## Target Superheat (TSH)

Compare target superheat (TSH) to actual superheat (SH) when charging fixed orifice air conditioning systems. TSH is continually calculated from indoor wet bulb (IDWB) and outdoor dry bulb (ODDB) temperatures.

**IDWB:** By default, this is a manually set value of 60.0°F.

For a live measurement, assign the optional model JL3RH wireless psychrometer. See LINK TOOL on page 19.

**ODDB:** By default, this is the live measurement of the ODDB thermocouple jack. If you prefer a static measurement, assign a manual value. NOTE: Use your wireless psychrometer (JL3RH or PRH3) by pressing MENU > ToolSet > Outdoor (ODDB flashing) > SELECT > Arrows between Type K / Manual / ID-#### > SELECT.

1. Connect the included type K bead thermocouple to the ODDB thermocouple jack. Use the alligator clip to locate the bead in a shaded area of the condenser to measure the temperature of air entering the condenser.
2. Use **ARROWS** to scroll through detected measurement sources. *Job Link® System tools are displayed by their 4 digit ID, usually found on the back of the tool.*
3. Turn on any wireless sources you want to assign. *If your Job Link® System tool has a selector switch, ensure it's set to match the measurement.*
4. Press **SELECT** to select and exit or go to next until complete.
5. Press **T1-T2 / TSH / ODDB** until ODDB is displayed. *If you changed ODDB to a manually set value, it will be used to calculate TSH but will not be displayed.*
6. Measure IDWB after the filter, just in front of the indoor coil. If a psychrometer is assigned, you can press **AIR PARAMETER** until wet bulb is displayed to verify the measurement.
7. Press **T1-T2 / TSH / ODDB** until TSH is displayed.

# Deep Vacuum - Model SM382V

Follow recommended evacuation practices from equipment manufacturer and training. Alarms can be adjusted in the MENU (page 34).

1. Close all manifold valves.
2. Setup your tools and equipment (see diagram).  
*Connect manifold 1/4" HIGH port to liquid line service port.  
Connect manifold 1/4" LOW port to suction line service port.  
Connect manifold 1/4" middle port to vacuum pump with a shutoff valve in between.*
3. Turn on your vacuum pump.
4. Open shutoff valve.  
*The vacuum sensor is now exposed to your pump, but it will not display until HIGH/LOW manifold valves are opened. This ensures the measurement is of the system and not just the manifold.*
5. Open HIGH and LOW manifold valves.
6. Press **VAC ALARM** to activate the low alarm. See details on page 34.  
*The stopwatch starts. The rate of change is displayed in units per minute. Press **ARROWS** to switch between Rate Meter and Bar Graph views. The smaller the rate of change, the closer you are to stabilization. You may need to improve your setup if rate slows well before reaching your desired vacuum (see *Tips for Better Evacuations*). Note: The Rate Meter shows vacuum progress and eliminates uncertainty with a dynamic view. Bars displayed on the left side shows decreasing vacuum, bars in the center show a stable vacuum, and bars on the right side shows increasing vacuum. The Bar Graph is static and nonlinear for increased resolution at deeper vacuums.*
7. Once the low alarm level is reached, the backlight blinks and alarm sounds. Press any button (other than SELECT) to silence alarm.
8. Close your shutoff valve between the middle port and pump to block the pump.  
*Do not close HIGH and LOW valves or you'll block the system and measure just the manifold!*
9. Turn off your vacuum pump.
10. Press **VAC ALARM** to activate the high alarm and start the stopwatch.
11. Once the high alarm level is reached, the backlight blinks, alarm sounds, and the stopwatch stops. Press any button (other than SELECT) to silence alarm.
12. Close HIGH and LOW manifold valves.  
*The vacuum sensor is now blocked from the system (page 44).*

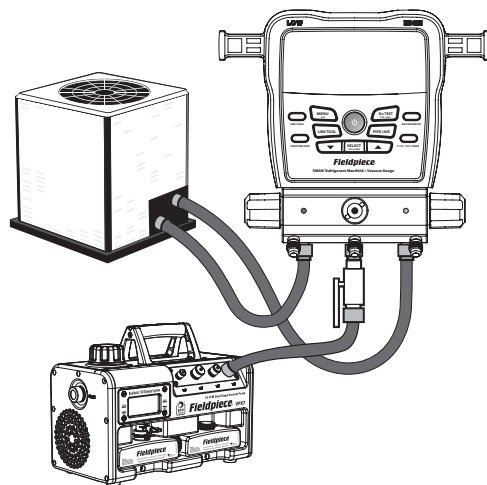

## Tips for Better Evacuations

- Remove Schrader valve cores & depressors with a core removal tool.
- Use shortest vacuum rated hoses with largest diameter available.
- Do not evacuate through hoses with low loss fittings.
- Inspect the rubber seals at both ends of your hoses for damage.
- Apply a light amount of vacuum oil to the service port fittings before attaching hoses to help maintain a vacuum-tight seal.
- Change pump oil before and during the job. Change pump oil on-the-fly without losing vacuum with Fieldpiece vacuum pumps.
- When the vacuum pump is blocked, a slow rise that stabilizes may signify moisture is still present in the system. A continuous rise to atmosphere indicates a leak. Check hoses, tools, or the system itself.
- Measurements are less representative of the entire system when the vacuum pump is on because pumping creates a pressure gradient. Block the pump and allow the system to stabilize before assuming the measurement is of the entire system.

# Deep Vacuum - Model SM482V

Follow recommended evacuation practices from equipment manufacturer and training. Alarms can be adjusted in the MENU (page 34).

1. Close all manifold valves.
2. Setup your tools and equipment (see diagram).  
*Connect manifold 1/4" HIGH port to liquid line service port.  
Connect manifold 1/4" LOW port to suction line service port.  
Connect manifold 3/8" VAC port to vacuum pump.*
3. Turn on your vacuum pump.
4. Open VAC valve.  
*The vacuum sensor is now exposed to your pump, but it will not display until HIGH/LOW manifold valves are opened. This ensures the measurement is of the system and not just the manifold.*
5. Open HIGH and LOW manifold valves.
6. Press **VAC ALARM** to activate the low alarm. See details on page 34.  
*The stopwatch starts. The rate of change is displayed in units per minute. Press **ARROWS** to switch between Rate Meter and Bar Graph views. The smaller the rate of change, the closer you are to stabilization. You may need to improve your setup if rate slows well before reaching your desired vacuum (see *Tips for Better Evacuations*). Note: The Rate Meter shows vacuum progress and eliminates uncertainty with a dynamic view. Bars displayed on the left side shows decreasing vacuum, bars in the center show a stable vacuum, and bars on the right side shows increasing vacuum. The Bar Graph is static and nonlinear for increased resolution at deeper vacuums.*
7. Once the low alarm level is reached, the backlight blinks and alarm sounds. Press any button (other than SELECT) to silence alarm.
8. Close VAC valve to block the pump.  
*Do not close HIGH and LOW valves or you'll block the system and measure just the manifold!*
9. Turn off your vacuum pump.
10. Press **VAC ALARM** to activate the high alarm and start the stopwatch.
11. Once the high alarm level is reached, the backlight blinks, alarm sounds, and the stopwatch stops. Press any button (other than SELECT) to silence alarm.
12. Close HIGH and LOW manifold valves.  
*The vacuum sensor is now blocked from the system (page 44).*

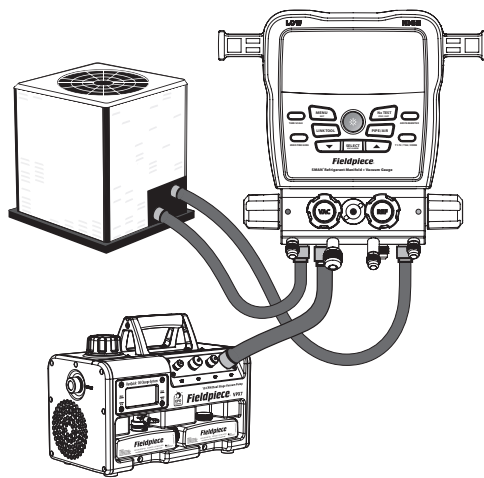

## Tips for Better Evacuations

- Remove Schrader valve cores & depressors with a core removal tool.
- Use shortest vacuum rated hoses with largest diameter available.
- Do not evacuate through hoses with low loss fittings.
- Inspect the rubber seals at both ends of your hoses for damage.
- Apply a light amount of vacuum oil to the service port fittings before attaching hoses to help maintain a vacuum-tight seal.
- Change pump oil before and during the job. Change pump oil on-the-fly without losing vacuum with Fieldpiece vacuum pumps.
- When the vacuum pump is blocked, a slow rise that stabilizes may signify moisture is still present in the system. A continuous rise to atmosphere indicates a leak. Check hoses, tools, or the system itself.
- Measurements are less representative of the entire system when the vacuum pump is on because pumping creates a pressure gradient. Block the pump and allow the system to stabilize before assuming the measurement is of the entire system.

# Test for Non-Condensables

If head pressure seems high even after cleaning coils, optimizing airflow, and other routine maintenance, you may have non-condensables trapped in the system or a low refrigerant charge. Non-condensables can reduce efficiency, performance, and put extra stress on system components. Non-condensables can enter the system in many ways, and your initial system service may be following years of poor service that introduced the non-condensables.

1. Use **ARROWS** to select the system refrigerant.
2. Unpower the compressor, but allow the condenser fan to run.
3. Connect high side port to the system to view system pressure.
4. Clamp one thermocouple to the discharge line.
5. Clamp the other thermocouple to the liquid line.
6. Clip the ODDB thermocouple to measure the air entering the condenser.
7. Monitor all three temperatures until they all stabilize and show the same value.
8. View the subcooling (SC) calculation on the display.  
*The closer SC is to 0.0°, the fewer non-condensables are trapped. Depending on the system, a negative SC may suggest a need to recover, evacuate, and charge with virgin refrigerant.*

# Menu

Press MENU to enter the menu where most settings are located. Use arrows to scroll through the menu and press SELECT to select one of the below menu items. NOTE: Starts from MENU function most recently entered.

**LogData:** Enter data logging setup mode (page 30).

**(StopLog):** If data logging, stop the log (page 30).

**AutoOff:** Enter auto off timer setup mode (page 31).

**CalTemp:** Enter calibration mode for Type K jacks (page 32).

**-> Disable:** Select to turn OFF wireless functionality.

**-> Enable:** Select to turn ON wireless functionality.

**ToolSet:** Enter wireless source setup mode (page 33).

**Units:** Enter units setup mode (page 34).

**Vac Alarms:** Enter vacuum alarm setup mode if gauge is assigned (page 34).

**Mute:** If unmuted, mute the speaker.

**(Unmute):** If muted, unmute the speaker.

**Backlight Timer:** Enter backlight timer setup mode (page 35).

**Enable N2 Temp. Comp.:** Enable N2 Test Parameters if OFF.

**(Disable N2 Temp. Comp.):** Disable N2 Test Parameters if ON.

**Adv Pressure Cal:** Enter advanced calibration mode for pressure sensors (page 36).

**F Ware:** Enter firmware view and update mode (page 38).

**Language:** Select your language (English, German, French, Portuguese, Italian, Spanish, Danish, Dutch, Finnish, Swedish, Turkish, or Norwegian).

**Restore Settings:** Enter restore factory settings mode (page 38).

**(Delete Log File):** If a Job .csv log file is saved to the internal flash drive, enter delete log file mode (page 39).

**Format Drive:** Enter format drive mode (page 39).

# Data Logging

Log measurements and resulting calculations, such as Superheat, at chosen spans and intervals. Save up to 9 Jobs (logs) to the internal flash drive.

## MENU/LogData

1. Use **ARROWS** to scroll through Jobs.  
*The display will alternate between the % free space on the drive and the % of space the chosen Job uses.*
2. Press **SELECT** to select.  
*If a Job already exists in that slot, use ARROWS then SELECT to choose whether or not you want to save over that Job.*
3. Use **ARROWS** to set the Span (total time).  
*It's a good idea to use new batteries if setting up a long span. If batteries run out during a Job, the log will automatically stop and save, then the SMAN® manifold will turn off.*
4. Press **SELECT** to select.
5. Use **ARROWS** to set the Interval (time between measurements).
6. Press **SELECT** to select and begin logging data until the Span ends.  
*LOG will blink to indicate the log is still active.*

- Press **MENU** to exit setup at any time.
- Press **MENU** and select **StopLog** to stop the Job and return to standard operation. The Job will be saved.
- To save battery life, the screen will turn off after 3 hours of logging, but will continue to log. Press any button to turn the screen on.
- Some buttons and features (including auto power off) are disabled until the Job ends.
- Jobs are saved as .csv files.
- Connect to your computer via the USB-C port under the removable rubber cover. View its internal flash drive just like any other USB drive.

# Auto Power Off (APO)

To save battery life, your SMAN® manifold automatically powers off after a set time of no button presses.

## MENU/AutoOff

1. Use **ARROWS** to scroll through times (default is 30 min).
  2. Press **SELECT** to select and exit. *If changes were made, choose whether or not you want to save changes.*
- Press **MENU** to exit at any time. *If changes were made, choose whether or not you want to save changes.*
  - APO is automatically disabled when in Deep Vacuum, N2 Test, Firmware update and data logging modes.



# Temperature Calibration (CalTemp)

Thermocouples (T/C) are not calibrated directly. Instead, each T/C jack (LLT, ODDDB, SLT) must be calibrated to the particular T/C that is plugged into it. Though it's possible for a calibration to hold for years, it's best practice to calibrate regularly if only to verify accuracy.

Calibration is quick and easy, requiring just a known temperature to calibrate to. Ice water is the recommended medium for in-field calibration due to known temperature (32.0 F, 0.0 C) and ready availability.

## MENU/CalTemp

1. Stabilize a large cup of ice water by stirring. Pure, distilled water will be the most accurate.
  2. Immerse the sensing end of the thermocouple in the ice water.
  3. Use **ARROWS** to select the temperature you want to calibrate (ODDB, SLT, or LLT).
  4. Press **SELECT** to select.
  5. Use **ARROWS** to adjust the temperature to match 32.0°F (0.0°C) making sure the ice water is continually stirred. *The calibration range is limited to  $\pm 7^{\circ}\text{F}$  ( $\pm 3.8^{\circ}\text{C}$ ) in order to help prevent mistakes.*
  6. Press **SELECT** to save and return to the list of temperatures.
- Press **MENU** to exit at any time. *If changes were made, choose whether or not you want to save changes.*
  - If you have a wireless thermocouple (model JL3PC) assigned and wireless is on, calibration is for the wireless thermocouple.
  - Calibration of a wireless thermocouple (model JL3PC) does not override a wired thermocouple calibration. You can switch between wired and wireless without having to recalibrate.

# ToolSet

Assign wireless Job Link® System tools to core manifold measurements such as pipe temperature or to broader measurements such as refrigerant weights and psychrometrics.

**Wireless OFF:** Wireless is disabled by default. Line temperatures (SLT and LLT) are automatically assigned to their type K jacks.

**Wireless ON:** SLT and LLT type K jacks DO NOT override an assigned wireless source. If wireless clamps are linked, the SLT and LLT ports are disabled.

## MENU/ToolSet

1. Use **ARROWS** to scroll through the list of measurements.
  2. Press **SELECT** to select.
  3. Turn on any wireless sources you want to assign.  
*If your Job Link® System tool has a selector switch, ensure it's set to match the measurement.*
  4. Use **ARROWS** to scroll through detected measurement sources.  
*Job Link® System tools are displayed by their 4 digit ID, usually found on the back of the tool.*
  5. Press **SELECT** to select and return to the list of measurements.
- Press **MENU** to exit at any time. *If changes were made, choose whether or not you want to save changes.*
  - Most Job Link® System tools have a switch that selects a side of the system. Set it to match the measurement you're assigning it to.
  - Depending on the wireless tool, select **Unlink, Type K, or Onboard** to set a source to its factory default source. This is useful when you want to use a previously assigned tool at the job site, but do not want to use it with the SMAN® manifold.
  - A wireless Return psychrometer is assigned to both Return air and IDWB (page 23) when selected.

# Units

Each measurement can have its own unit of measure.

## MENU/Units

1. Use **ARROWS** to scroll through the list of measurements.
  2. Press **SELECT** to select.
  3. Use **ARROWS** to scroll through units of measure.
  4. Press **SELECT** to select and return to the list of measurements.
- Press **MENU** to exit at any time. *If a change was made before pressing SELECT, choose whether or not you want to save the change.*

# Vacuum Alarms

Set high and low vacuum alarms so you know when you've reached an appropriate vacuum (Low) and time how long it takes to rise after blocking the pump from the system (High).

## MENU/Vac Alarms

1. Use **ARROWS** to toggle between high and low alarm.
  2. Press **SELECT** to select.
  3. Use **ARROWS** to adjust the alarm trigger in 25 micron increments.
  4. Press **SELECT** to select and exit or go to next.
- Press **MENU** to exit at any time. *If changes were made, choose whether or not you want to save changes.*
  - The low alarm cannot go higher than the high alarm.
  - The high alarm cannot go lower than the low alarm.
  - Press **SELECT (ALARM)** while in deep vacuum to activate the next alarm (None >> Low >> High >> None).

# Backlight Timer

The backlight turns off automatically after a set time of no button presses.

## MENU/Backlight Timer

1. Use **ARROWS** to scroll through times (default is 2 min).
  2. Press **SELECT** to select and exit. *If changes were made, choose whether or not you want to save changes.*
- Press **MENU** to exit at any time. *If changes were made, choose whether or not you want to save changes.*

# Advanced Pressure Calibration

Typical HVACR service does not require this procedure, but you can occasionally calibrate the pressure sensors to maintain highest accuracy.

It works by measuring the temperature of virgin refrigerant (not recovered refrigerant) and applying an offset to match the pressure to that refrigerant's P-T chart.

1. Calibrate a beaded thermocouple to the ODDB jack (page 32).
2. Store a virgin refrigerant cylinder, upright and untouched, in the stable ambient environment for at least 24 hours.
3. Leaving the cylinder in the same place it was left to stabilize, connect the cylinder to either the HIGH or LOW side port.
4. Close VAC and REF valves and cap the unused port.  
*If you don't have caps with seals, you can connect both ends of a refrigerant hose to the unused ports or hose seats. Some refrigerant will remain in the hoses which you need to recover after calibration.*
5. Use **ARROWS** to select the refrigerant type in the cylinder.
6. Use tape to attach the ODDB thermocouple bead halfway up the cylinder to measure the temperature of the refrigerant.
7. Press **T1-T2 / TSH / ODDB** until ODDB is displayed.
8. Open both HIGH and LOW side manifold valves.
9. Open the refrigerant cylinder valve.

*The pressure inside cylinder should now be displayed on both HIGH and LOW side pressure sensors.*

10. Allow the pressure readings and ODDB temperature to stabilize.
11. Press **MENU**.
12. Use **ARROWS** to show **Adv Pressure Cal**.
13. Press **SELECT** to initiate calibration of the pressure sensors.
14. Each pressure sensor will briefly display "Good" if successful or "Err" if unsuccessful, then return to normal operating mode.

## Troubleshooting an "Err" message

1. Measured pressure was less than 10 psig.
  - *Refrigerant cylinder may be nearly empty.*
  - *Valves may be closed.*
2. Measured pressure was not within  $\pm 3$ psig of VSAT pressure on the P-T chart.
  - *Thermocouple may not have been calibrated properly.*
  - *Thermocouple may not have been attached properly to cylinder.*
  - *Thermocouple may have not been connected to ODDB jack.*
  - *Refrigerant cylinder pressure was unstable.*
  - *Refrigerant cylinder temperature was unstable.*
  - *Refrigerant selected did not match refrigerant in cylinder.*

## Firmware View and Update

Firmware often becomes available as new refrigerants and features become available.

Before entering this mode, download from [www.fieldpiece.com](http://www.fieldpiece.com) and transfer from the computer to the manifold via the USB-C port on the rear of the manifold.

### MENU/F Ware

1. View the firmware version on the top line, P/T chart on the second line, and radio region on the bottom line.
2. *If a new firmware file is found on the internal flash drive from the USB-C transfer, the new version(s) will be shown. Using the arrows, SELECT YES or NO, whether or not you want to update.*
3. Once installation begins you will see a bar moving across the screen. “donE” will appear and your SMAN® manifold will turn off when finished.
  - Press **MENU** to exit at any time before installation begins.
  - During installation, buttons are disabled.
  - User settings & log files are not deleted.

## Restore User Settings

Restore factory default user settings when you want a fresh start.

### MENU/Restore Settings

1. Use **ARROWS** to select Yes or No.
2. Press **SELECT** to select and exit.
3. Press **MENU** to exit at any time. *If changes were made, choose whether or not you want to save changes.*
  - If you choose to restore, it may take a few seconds before returning to standard operation.

## Delete Log File

Clear up space by deleting old logs or just view free space available.

### MENU/Delete Log File

1. Use **ARROWS** to scroll through Jobs (logs). *The display will alternate between the % free space on the drive and the % of space the chosen Job uses.*
2. Press **SELECT** to select a Job to delete. *Choose whether or not you want to delete that Job.*
3. If you choose to delete, it may take a few seconds to finish. If no additional Jobs are found, the manifold returns to standard operation.
  - Press **MENU** to exit at any time.

## Format Internal Flash Drive

Quickly clear up maximum space by reformatting the internal flash drive. This deletes everything on the drive including log files, firmware update files, and any other files added manually.

### MENU/Format Drive

1. Use **ARROWS** to select Yes or No.
2. Press **SELECT** to select and exit.
  - Press **MENU** to exit at any time.
  - If you choose to format, it may take a few seconds before returning to standard operation.
  - User settings are not deleted.

# Maintenance

## Cleaning

Wipe with damp cloth to clean the exterior. Do not use solvents.

Over time, the vacuum sensor of the SMAN may become contaminated with dirt, oil, and other contaminants. If you are frequently flowing refrigerant through the manifold and exposing the vacuum sensor to this flow, we recommend that users should flush or clean their manifold every 2 to 4 weeks to extend the life of the SMAN by avoiding contaminants from building up on the sensor components.

1. Never use an object such as a cotton swab to clean the sensor, you may cause damage to the sensor.
2. Open all valves and cap all the ports except for the VAC port on a 4-port manifold or the center port on a 3-port manifold. Turn the manifold over such that the manifold ports (not hose holders) are facing up.
3. Drop enough Isopropyl (rubbing) alcohol (minimum 70% alcohol content) into the VAC/center port using an eye dropper or funnel so that it can flush out contaminants. (Roughly 7 mL)
4. Cap off the VAC/center port and gently shake your SMAN while upside down to clean sensor. (Approximately 30 to 60 seconds.)
5. Turn right side up. Uncap one of the ports and pour out the rubbing alcohol. Uncap and open all ports to allow sensors to dry out. Drying usually takes about an hour.

## Battery Replacement

The batteries must be replaced when the battery life indicator is empty. Once the batteries are drained beyond operating voltage, "Low Bat" briefly appears and the manifold turns off.

Unscrew the 4 cover screws and pull out the rear battery cover. Replace the 6 AA batteries and properly dispose of the old ones.

## Using Different Refrigerants

You can use different refrigerants, but be sure to purge your manifold block and hoses with nitrogen before connecting to a system with a different refrigerant. Contamination can hurt system performance and cause damage.

## Spare Parts

- RSM82H – SMx82V Hose Holder Replacement Kit – 1/4" + 5/16"
- RSM82E – SMx82V Pipe Clamp Ear Replacement Kit
- RSMANK6 – SMAN 2 Valve and Knob Kit
- RSMANK8 – SMAN 4 Valve and Knob Kit

## Hose Holder Replacement

Your manifold hose holders are 1/4" as the default. If you want to change them to the 5/16" (silver color) hose holders or replace a damaged 1/4" hose holder, please complete the following.

1. Lay your manifold face up on a non-abrasive, flat surface.
2. Insert a thin shafted, Phillips screwdriver into the desired hose holder. Turn the screw counter clockwise to loosen and remove the 1/4" (brass color) hose holder. Take care to not damage or strip the screw head.
3. Replace the sealing o-ring with a new o-ring. Ensure that the o-ring does not block the threaded screw hole.
4. Insert the replacement hose holder and align it to the flats in the manifold block so that the bottom of the fitting is flush with the manifold block.
5. Insert a new screw into the replacement hose holder. Do NOT re-use the old screw. Use your screwdriver to securely tighten. The provided screws are pre-coated with threadlocker. Do NOT overtighten.
6. Store the 1/4" hose holder in a safe and secure place for future use.

## Pipe Clamp Storage Arm Replacement

Your pipe clamp storage arms can easily be replaced if they become damaged or capped if unused.

1. Lay your manifold face down on a non-abrasive, flat surface.
2. Using a Phillips screwdriver, loosen the screw by turning it counter clockwise.
3. Discard the damaged storage arm and screw.
4. Select the correct side replacement, or cap (LLT or SLT), and slide in to securely insert. Ensure it is flush with the manifold body.
5. Insert a new screw, use your screwdriver to securely tighten. Do NOT re-use the old screw. Do NOT overtighten.

## Valve and Knob Replacement

If you are experiencing vacuum leaks through your valve(s), gauges are inaccurate, or there is physical damage, please complete the following to rebuild.

1. Lay your manifold face up on a non-abrasive, flat surface.
2. On the valve(s) you are replacing, pry, lift and remove the knob's label to expose the knob's screw.
3. With a Phillips screwdriver, turn the screw counter clockwise to loosen and remove the knob. Do NOT re-use the old screw.
4. Using a 20 mm wrench, loosen the old valve by turning it counter clockwise. Once loose, pull straight up to remove.
5. On the replacement valve, apply a thin layer of silicone grease to the o-rings. Push the valve back in, tighten by hand and complete with your wrench until tight. Do NOT overtighten. Use a threadlocker if desired.
6. Put on the new knob and twist until tight. Use the new screw and turn clockwise until tight onto the valve stem. Use a threadlocker if desired.
7. Stick on the correct replacement label depending on which valve you replaced.
8. Depending on how many valves you are replacing, repeat steps 2-7 as needed.

# Specifications

**Display:** LCD (5 inches diagonal)

**Backlight:** Blue (adjustable duration)

**Low Battery Indication:**  is displayed when the battery voltage drops below the operating level.

**Over Range Display:** OL for pressure, --- for temperature

**Auto Power Off:** 30 minutes of inactivity (adjustable)

**Maximum Manifold Pressure:** 870 Psig (5998 kPa)

**Battery Type:** 6 x AA alkaline

**Battery Life:** 405 hours typical

(without vacuum, backlight, and wireless)

**Radio Frequency:** 2.4 GHz

**Wireless Range:** 1000 feet (305 meters) line of sight.

Distance decreases through obstructions.

**Data Port:** USB-C (for extracting data logs or updating firmware)

**Operating Environment:** 14°F to 122°F (-10°C to 50°C) at <75% RH

**Storage Environment:** -4°F to 140°F (-20°C to 60°C) at <80% RH  
(with battery removed)

**Temperature Coefficient:** 0.1 x (specified accuracy) per 1.8°F (14°F to 64°F, 82°F to 122°F), per °C (-10°C to 18°C, 28°C to 50°C)

**Weight:** SM382V: 3.31 lbs (1.5 kg); SM482V: 3.97 lbs (1.8 kg)

**Water Resistant:** Tested to IP55

**US Patent:** [www.fieldpiece.com/patents](http://www.fieldpiece.com/patents)

**Refrigerants:** New refrigerants are continually being added so be sure to visit [www.fieldpiece.com](http://www.fieldpiece.com) for the latest firmware.

R11	R115	R290	R407A	R414A	R422A	R438A	R458A	R600
R12	R116	R401A	R407C	R414B	R422B	R448A	R500	R600A
R13	R123	R401B	R407F	R416A	R422C	R449A	R501	R601
R22	R124	R402A	R407H	R417A	R422D	R450A	R502	R601A
R23	R125	R402B	R408A	R417C	R424A	R452A	R503	R744*
R32	R134A	R403B	R409A	R420A	R427A	R452B	R507A	R1233ZD
R113	R236FA	R404A	R410A	R421A	R428A	R453A	R508B	R1234YF
R114	R245FA	R406A	R413A	R421B	R434A	R454B	R513A	R1234ZE

\*Maximum pressure: 870 Psig (6000 kPa)

## Temperature

**Sensor Type:** Type K thermocouple  
(nickel chromium/nickel aluminum)

**Jack Type:** (3) Type K thermocouple

**Range:** -50°F to 257°F (-46°C to 125°C), limited by the thermocouple specification. Display range is -95°F to 999.9°F (-70°C to 537.0°C).

**Resolution:** 0.1°F (0.1°C)

**Accuracy:** Shown accuracies are after field calibration.

±(1.0°F) -95°F to 200°F, ±(2.0°F) 200°F to 999.9°F;

±(0.5°C) -70°C to 93°C, ±(1.0°C) 93°C to 537.0°C

## Pressure

**Sensor Type:** Absolute pressure sensors

**Port Type:** SM382V: (3) 1/4" standard SAE male flare fittings, or

SM482V: (1) 3/8" and (3) 1/4" standard SAE male flare fittings

**Pressure Range and Units:** 870 Psig (English), 60.00 Bar (Metric), 6.000 MPa (Metric), and 6000 kPa (Metric)

**Negative Pressure Range and Units:**

29 inHg (English), 74 cmHg (Metric), 0.98 Bar (Metric)

**Resolution:** 0.1 Psig; 0.01 Bar; 0.001 MPa; 1 kPa; 0.1 inHg; 1 cmHg

**Negative Pressure Accuracy:**

29 inHg to 0 inHg: ±0.2 inHg;

74 cmHg to 0 cmHg: ±1 cmHg

0.98 Bar to 0 Bar; ±0.01 Bar

**Pressure Accuracy:**

0 Psig to 200 Psig: ±1 Psig;

200 Psig to 870 Psig: ±(0.3% of reading + 1 Psig);

0 Bar to 13.78 Bar ±0.07 Bar;

13.78 Bar to 60.00 Bar: ±(0.3% of reading + 0.07 Bar);

0 MPa to 1.378 MPa: ±0.007 MPa;

1.378 MPa to 6.000 MPa: ±(0.3% of reading + 0.007 MPa);

0 kPa to 1378 kPa: ±7 kPa;

1378 kPa to 6000 kPa: ±(0.3% of reading + 7 kPa)

# Deep Vacuum

**Sensor Type:** Thermistor

**Port Type:** SM382V: (3) 1/4" standard SAE male flare fittings, or  
SM482V: (1) 3/8" and (3) 1/4" standard SAE male flare fittings

## Range and Units:

- 50 to 9999 microns of mercury (English),
- 6.7 to 1330 Pascals (Metric),
- 0.067 to 13.30 mBar (Metric),
- 50 to 9999 mTorr (Metric),
- 0.050 to 9.999 Torr (Metric, equivalent to mmHg)

## Best Resolution:

- 1 micron of mercury (below 2000 microns),
- 0.1 Pascal (below 250 Pascals),
- 0.001 mBar (below 2.500 mBar),
- 1 mTorr (below 2000 mTorr),
- 0.001 Torr (below 2.000 Torr)

## Accuracy @ 25°C (77°F):

- ±(5% of reading + 5 microns of mercury), 50 to 2000 microns
- ±(5% of reading + 1.0 Pascal), 6.7 to 266.0 Pascal
- ±(5% of reading + 0.010 mBar), 0.067 to 2.660 mBar
- ±(5% of reading + 5 mTorr), 50 to 2000 mTorr
- ±(5% of reading + 0.005 Torr), 0.067 to 2.000 Torr

# Wireless Compatibility

*Latest compatibility at [www.fieldpiece.com](http://www.fieldpiece.com)*

## Job Link System Minimum Device Requirement:

BLE 4.0 devices running iOS 7.1 or Android™ Kitkat 4.4

## Wireless Measurement Source Assignments:

- Suction line temperature: Fieldpiece model JL3LC/PC (set to blue)
- Liquid line temperature: Fieldpiece model JL3LC/PC (set to red)
- Supply air psychrometer: Fieldpiece model JL3RH (set to blue)
- Return air psychrometer: Fieldpiece model JL3RH (set to red)
- Outdoor air psychrometer: Fieldpiece model JL3RH (set to red or blue)
- Refrigerant weight scale: Fieldpiece models SRS3 or SR47

46 Vacuum: Fieldpiece model MG44

# Manifold Diagrams

## SM382V:

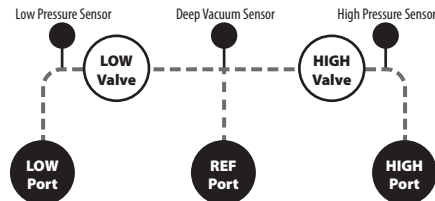

## SM482V:

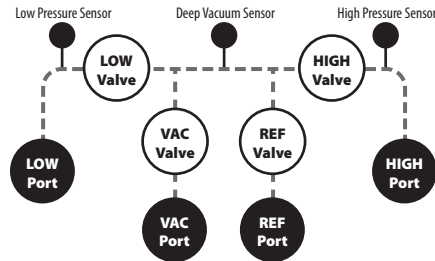

# Certifications and Module IDs



EN 300 328



Regulatory Compliance Mark



UK Conformity Assessed



Waste Electrical and Electronic Equipment



IC: Industry Canada



RoHS  
Restriction of Hazardous  
Substances Compliant



# FCC Statement

This equipment has been tested and found to comply with the limits for a Class B digital device, pursuant to Part 15 of the FCC Rules. These limits are designed to provide reasonable protection against harmful interference in a residential installation.

This equipment generates, uses and can radiate radio frequency energy and, if not installed and used in accordance with the instructions, may cause harmful interference to radio communications. However, there is no guarantee that interference will not occur in a particular installation. If this equipment does cause harmful interference to radio or television reception, which can be determined by turning the equipment off and on, the user is encouraged to try to correct the interference by one of the following measures:

- . Reorient or relocate the receiving antenna.
- . Increase the separation between the equipment and receiver.
- . Connect the equipment into an outlet on a circuit different from that to which the receiver is connected.
- . Consult the dealer or an experienced radio/TV technician for help.

**FCC Caution:** To assure continued compliance, any changes or modifications not expressly approved by the party responsible for compliance could void the user's authority to operate this equipment. (Example - use only shielded interface cables when connecting to computer or peripheral devices).

**FCC Radiation Exposure Statement:** This equipment complies with FCC RF radiation exposure limits set forth for an uncontrolled environment. This equipment should be installed and operated with a minimum distance of 0.5 centimeters between the radiator and your body.

This transmitter must not be co-located or operating in conjunction with any other antenna or transmitter.

The antennas used for this transmitter must be installed to provide a separation distance of at least 0.5 cm from all persons and must not be co-located or operating in conjunction with any other antenna or transmitter.

This device complies with Part 15 of the FCC Rules. Operation is subject to the following two conditions:

- (1) This device may not cause harmful interference, and
- (2) This device must accept any interference received, including interference that may cause undesired operation.

# Industry Canada Statement

This device contains licence-exempt transmitter(s)/receiver(s) that comply with Innovation, Science and Economic Development Canada's licence-exempt RSS(s). Operation is subject to the following two conditions:

- (1) This device may not cause interference.
- (2) This device must accept any interference, including interference that may cause undesired operation of the device.

L'émetteur/récepteur exempt de licence contenu dans le présent appareil est conforme aux CNR d'Innovation, Sciences et Développement économique Canada applicables aux appareils radio exempts de licence. L'exploitation est autorisée aux deux conditions suivantes :

- 1) L'appareil ne doit pas produire de brouillage;
- 2) L'appareil doit accepter tout brouillage radioélectrique subi, même si le brouillage est susceptible d'en compromettre le fonctionnement.

**IC Radiation Exposure Statement:** This equipment complies with RSS-102 radiation exposure limit set forth for an uncontrolled environment. This equipment should be installed and operated with minimum distance 0.5 cm between the radiator and your body.

Cet équipement est conforme aux CNR-102 d'Industrie Canada. Cet équipement doit être installé et utilisé avec une distance minimale de 0.5 centimètres entre l'émetteur et votre corps. Cet émetteur ne doit pas être co-localisé ou opérant en conjonction avec autre antenne ou émetteur. Les antennes utilisées pour cet émetteur doivent être installés et fournir une distance de séparation d'au moins 0.5 centimètre de toute personne et doit pas être co-située ni fonctionner en conjonction avec une autre antenne ou émetteur.

# Limited Warranty

This product is warranted against defects in material or workmanship for one year from date of purchase from an authorized Fieldpiece dealer. Fieldpiece will replace or repair the defective unit, at its option, subject to verification of the defect.

This warranty does not apply to defects resulting from abuse, neglect, accident, unauthorized repair, alteration, or unreasonable use of the machine.

Any implied warranties arising from the sale of a Fieldpiece product, including but not limited to implied warranties of merchantability and fitness for a particular purpose, are limited to the above. Fieldpiece shall not be liable for loss of use of the machine or other incidental or consequential damages, expenses, or economic loss, or for any claim of such damage, expenses, or economic loss.

State and country laws vary. The above limitations or exclusions may not apply to you.

Intentionally Blank

## Obtaining Service

Visit [www.fieldpiece.com/rma](http://www.fieldpiece.com/rma) for the latest information on how to obtain service.

For customers outside the U.S., warranty for products should be handled through local distributors.

Visit [www.fieldpiece-europe.com/store-locator](http://www.fieldpiece-europe.com/store-locator).

# ***SM382V***

# ***SM482V***



## **Job Link<sup>®</sup> System App**

### **Link your Tools. Link your Jobs.**

The Job Link<sup>®</sup> System works with all of our wireless tools—from clamps to probes to digital manifolds, and integrates all of their functionality seamlessly.

### **Download the app to get started!**

