



# Notice to customer Changing and calibrating lenses

## Copyright

© 2017, FLIR Systems, Inc.

All rights reserved worldwide. Names and marks appearing herein are either registered trademarks or trademarks of FLIR Systems and/or its subsidiaries. All other trademarks, trade names or company names referenced herein are used for identification only and are the property of their respective owners.

## Document identity

Publ. No.: T810264  
Release: AC  
Commit: 45029  
Head: 45029  
Language: en-US  
Modified: 2017-09-18  
Formatted: 2017-09-18

## Website

<http://www.flir.com>

## Customer support

<http://support.flir.com>

## Disclaimer

Specifications subject to change without further notice. Models and accessories subject to regional market considerations. License procedures may apply. Products described herein may be subject to US Export Regulations. Please refer to [exportquestions@flir.com](mailto:exportquestions@flir.com) with any questions.



T810264

## Table of contents

1 Thank you!	1
2 Applicability	1
3 Changing lenses (FLIR Exx series)	2
4 Changing lenses (FLIR T5xx series)	5
5 Calibrating the lens-camera combination	8
6 Customer support	9
7 Appendix	10

## 1 Thank you!

Thank you for choosing a product from FLIR Systems. We hope that the product will meet your expectations and that you will consider us again for your future needs.

## 2 Applicability

**Note** Part numbers subject to change and/or amendment without further notice. Please check <http://support.flir.com> for latest applicability data.

### 2.1 Lens applicability

Sales order P/N	Item P/N	Product denomination
T199588	T199106	Lens 14° + case
T199590	T199104	Lens 42° + case
T199589	T199105	Lens 24° + case

### 2.2 Camera applicability

P/N	Product denomination
78502-0101	FLIR E75 24°
78504-0101	FLIR E75 24° + 14°
78506-0101	FLIR E75 24° + 14° & 42°
78505-0101	FLIR E75 24° + 42°
78503-0101	FLIR E75 42°
78507-0101	FLIR E75 42° + 14°
78502-0201	FLIR E85 24°
78504-0201	FLIR E85 24° + 14°
78506-0201	FLIR E85 24° + 14° & 42°
78505-0201	FLIR E85 24° + 42°
78503-0201	FLIR E85 42°
78507-0201	FLIR E85 42° + 14°
78502-0301	FLIR E95 24°
78504-0301	FLIR E95 24° + 14°
78506-0301	FLIR E95 24° + 14° & 42°
78505-0301	FLIR E95 24° + 42°
78503-0301	FLIR E95 42°
78507-0301	FLIR E95 42° + 14°
79302-0101	FLIR T530 24°
79304-0101	FLIR T530 24° + 14°
79306-0101	FLIR T530 24° + 14° & 42°
79305-0101	FLIR T530 24° + 42°
79303-0101	FLIR T530 42°

P/N	Product denomination
79307-0101	FLIR T530 42° + 14°
79302-0201	FLIR T540 24°
79304-0201	FLIR T540 24° + 14°
79306-0201	FLIR T540 24° + 14° & 42°
79305-0201	FLIR T540 24° + 42°
79303-0201	FLIR T540 42°
79307-0201	FLIR T540 42° + 14°

### 3 Changing lenses (FLIR Exx series)

**Note** If the new lens has not been used with the camera before, the lens–camera combination must be calibrated after the lens has been mounted. See section 5 *Calibrating the lens–camera combination*, page 8 for information on how to do this.

**Note** Do not touch the lens surface when you change lenses. If this happens, clean the lens according to the instructions in 7.1 *Infrared lens*, page 10.

Follow this procedure:

1. Take a firm grip around the inner ring of the lens. Rotate the inner ring 30° counter-clockwise until it stops.

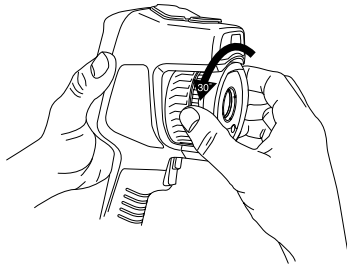

2. Carefully pull out the lens.

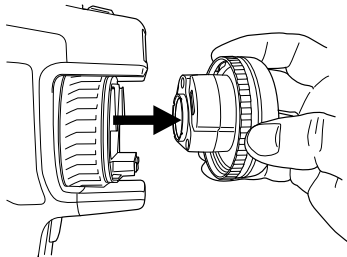

© 2017, FLIR Systems, Inc.  
#T810264; r. AC/45029/45029; en-US

3. The infrared detector is now fully exposed. Do not touch this surface. If you see dust on the detector, follow the instructions in 7.2 *Infrared detector*, page 10.

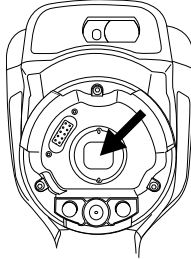

4. Make sure that the inner ring of the camera lens is fully in its open position.

- Correct: The tooth (1) is in its end position at the black stop pin (2).

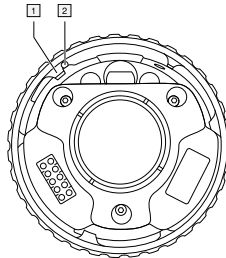

- Wrong: You must rotate the inner ring until the tooth (1) reaches the black stop pin (2).

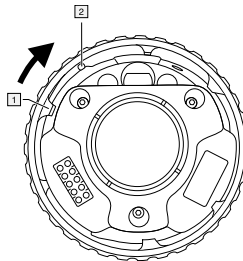

© 2017, FLIR Systems, Inc.  
#T810264; r. AC/45029/45029; en-US

5. Carefully push the lens into position.

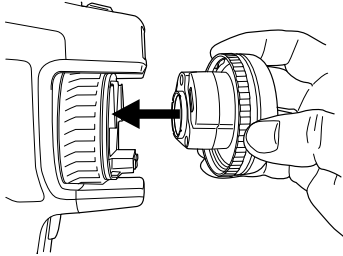

6. Rotate the inner ring of the lens 30° clockwise. The lens makes a click when it locks in place.

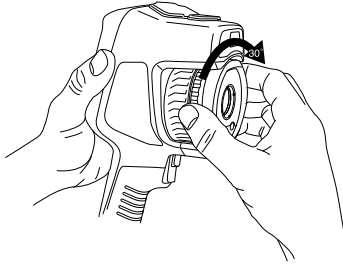

7. Make sure that the two index marks are aligned, indicating that the lens is locked in place.

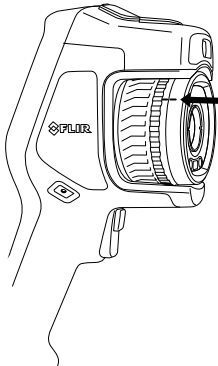

#### 4 Changing lenses (FLIR T5xx series)

**Note** If the new lens has not been used with the camera before, the lens-camera combination must be calibrated after the lens has been mounted. See section 5 *Calibrating the lens-camera combination*, page 8 for information on how to do this.

**Note** Do not touch the lens surface when you change lenses. If this happens, clean the lens according to the instructions in 7.1 *Infrared lens*, page 10.

Follow this procedure:

1. Take a firm grip around the inner ring of the lens. Rotate the inner ring 30° counter-clockwise until it stops.

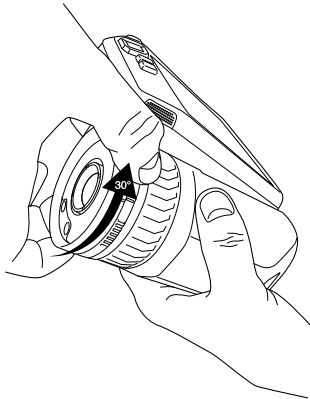

2. Carefully pull out the lens.

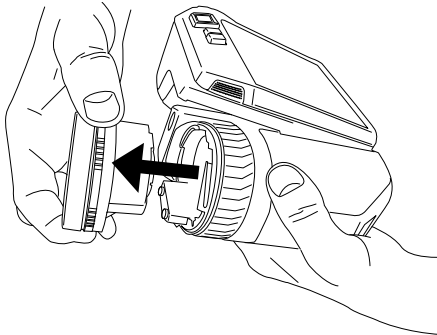

## Notice to customer Changing and calibrating lenses

© 2017, FLIR Systems, Inc.  
#T810264; r. AC/45029/45029; en-US

3. The infrared detector is now fully exposed. Do not touch this surface. If you see dust on the detector, follow the instructions in 7.2 *Infrared detector*, page 10.

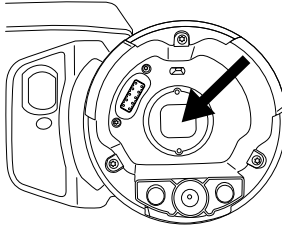

4. Make sure that the inner ring of the camera lens is fully in its open position.
  - Correct: The tooth (1) is in its end position at the black stop pin (2).

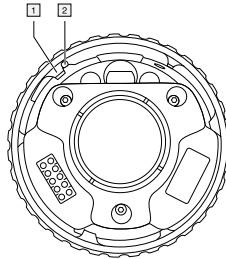

- Wrong: You must rotate the inner ring until the tooth (1) reaches the black stop pin (2).

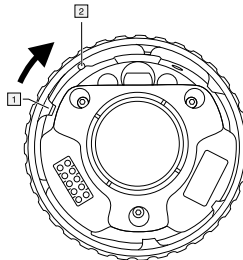

## Notice to customer Changing and calibrating lenses

© 2017, FLIR Systems, Inc.  
#T810264; r. AC/45029/45029; en-US

5. Carefully push the lens into position.

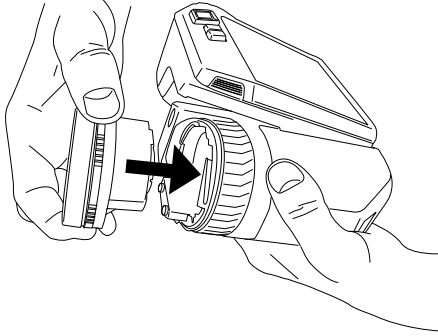

6. Rotate the inner ring of the lens 30° clockwise. The lens makes a click when it locks in place.

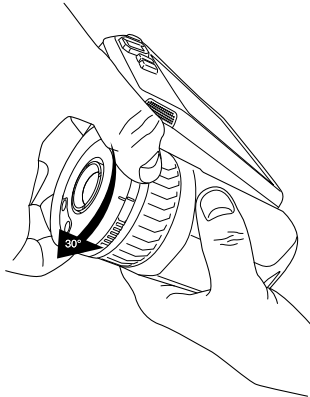

7. Make sure that the two index marks are aligned, indicating that the lens is locked in place.

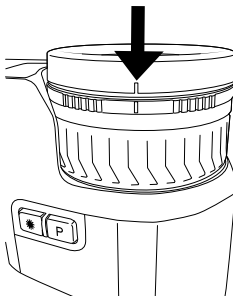

## 5 Calibrating the lens–camera combination

### 5.1 Introduction

Before a new lens can be used with the camera, the lens–camera combination must be *calibrated*.

This is a process that previously had to be performed by a FLIR service department, but for the FLIR Exx series and FLIR T5xx series the calibration can be performed by the user, using a calibration target. The calibration target is included in the lens package.

### 5.2 Procedure

**Note** The images below show a FLIR Exx series camera, but the procedure is similar for FLIR T5xx series cameras.

Follow this procedure:

1. Dip the calibration target in water for 1 second and let the excess drip off.

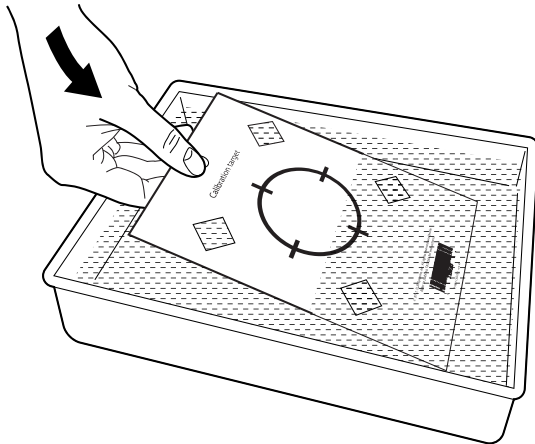

2. Tape or hang the calibration target on a wall.

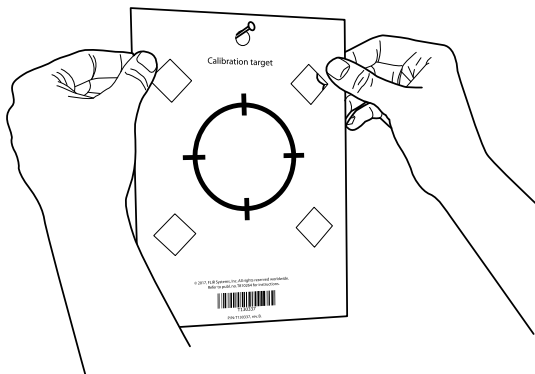



© 2017, FLIR Systems, Inc.  
#T810264; r. AC/45029/45029; en-US

3. Mount the new lens on the camera according to the procedure in section 3 *Changing lenses (FLIR Exx series)*, page 2 or section 4 *Changing lenses (FLIR T5xx series)*, page 5. When the lens is mounted, the calibration wizard starts automatically.
4. From a distance of 2 m (6.6 ft.), aim the camera toward the crosshair, using the laser pointer. The camera will take a picture automatically.



### NOTE

Make sure the camera's optical path is perpendicular to the calibration target. See the image below.

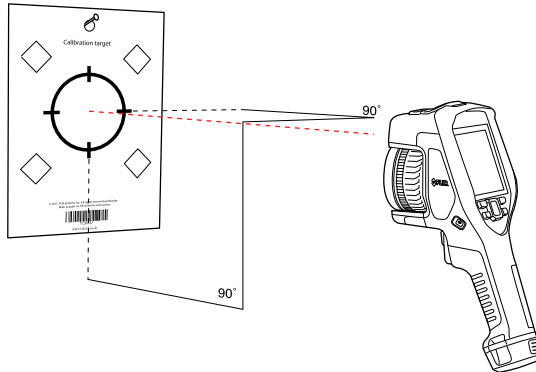

5. In the camera, align the thermal and visual images (indicated by the two squares in the image below), using the touchscreen arrows. The lens-camera combination is now calibrated.

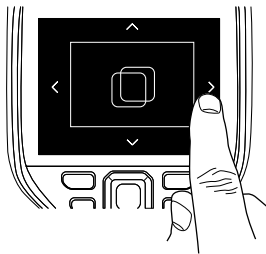

To repeat the procedure at a later time, go to *Settings > Camera information*.

## 6 Customer support

Do not hesitate to contact our Customer Support Center at <http://support.flir.com> if you experience problems or have any questions about your product.

## 7 Appendix

### 7.1 Infrared lens

#### 7.1.1 Liquids

Use one of these liquids:

- A commercial lens cleaning liquid with more than 30% isopropyl alcohol.
- 96% ethyl alcohol (C<sub>2</sub>H<sub>5</sub>OH).

#### 7.1.2 Equipment

Cotton wool

 <b>CAUTION</b>
If you use a lens cleaning cloth it must be dry. Do not use a lens cleaning cloth with the liquids that are given in section 7.1.1 above. These liquids can cause material on the lens cleaning cloth to become loose. This material can have an unwanted effect on the surface of the lens.

#### 7.1.3 Procedure

Follow this procedure:

1. Soak the cotton wool in the liquid.
2. Twist the cotton wool to remove excess liquid.
3. Clean the lens one time only and discard the cotton wool.

 <b>WARNING</b>
Make sure that you read all applicable MSDS (Material Safety Data Sheets) and warning labels on containers before you use a liquid: the liquids can be dangerous.

 <b>CAUTION</b>
<ul style="list-style-type: none"><li>• Be careful when you clean the infrared lens. The lens has a delicate anti-reflective coating.</li><li>• Do not clean the infrared lens too vigorously. This can damage the anti-reflective coating.</li></ul>

### 7.2 Infrared detector

#### 7.2.1 General

Even small amounts of dust on the infrared detector can result in major blemishes in the image. To remove any dust from the detector, follow the procedure below.

#### Note

- This section only applies to cameras where removing the lens exposes the infrared detector.
- In some cases the dust cannot be removed by following this procedure: the infrared detector must be cleaned mechanically. This mechanical cleaning must be carried out by an authorized service partner.

 <b>CAUTION</b>
In Step 2 below, do not use pressurized air from pneumatic air circuits in a workshop, etc., as this air usually contains oil mist to lubricate pneumatic tools.

#### 7.2.2 Procedure

Follow this procedure:

1. Remove the lens from the camera.
2. Use pressurized air from a compressed air canister to blow off the dust.