

QUICK START GUIDE

FLIR Duo™ PRO R

Please read the user manual for complete product information. If you have questions please call our Toll-Free Consumer Help Line at [866.667.7732](tel:866.667.7732) for assistance.

STEP 1: POWER TO THE CAMERA

The Duo Pro R requires 12W to function correctly. The camera cannot be powered via a computer USB port or most cell phone chargers. For power via USB-C, FLIR recommends a wall charger capable of supplying at least 12W.

The Duo Pro R can be powered through the USB-C port or through the 10-pin JST port using the cables included with the camera.

On initial power-up, LED 2 will flash red for approximately 15 seconds then change to solid Blue; LED 1 will turn solid green. This indicates that the device is ready for use.

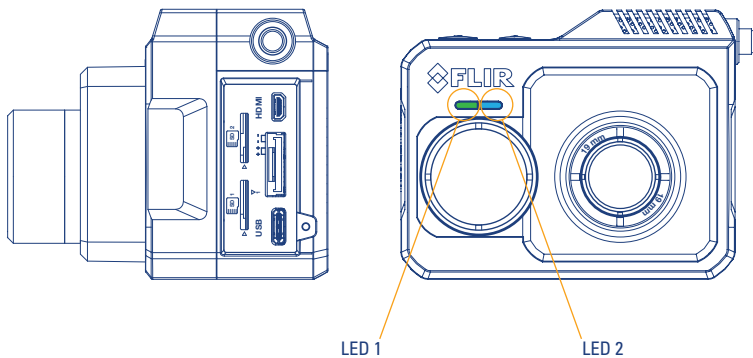

STEP 2: DISPLAY VIDEO

Duo Pro R can display either analog or digital video. To display analog video to a monitor or television, use the yellow RCA plug on the supplied Bench Cable to connect Duo Pro R to the monitor's video input.

For digital video, connect your camera to an HDMI display through the micro-HDMI camera port. This will automatically disable the analog video output and turn on the HDMI output.

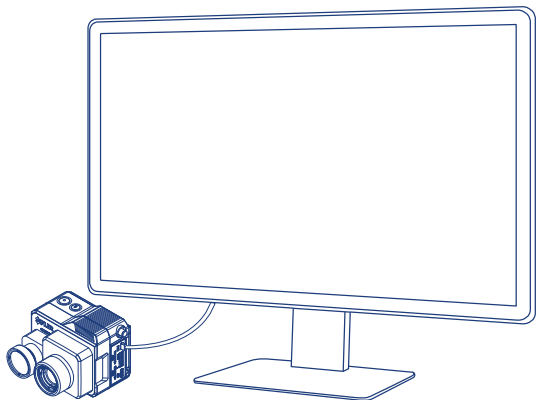

STEP 3: RECORDING VIDEO

Press the Record button to start recording video to the included memory cards. LED 1 will blink red to indicate active recording, and the camera will beep. Press the Record button again to stop recording video.

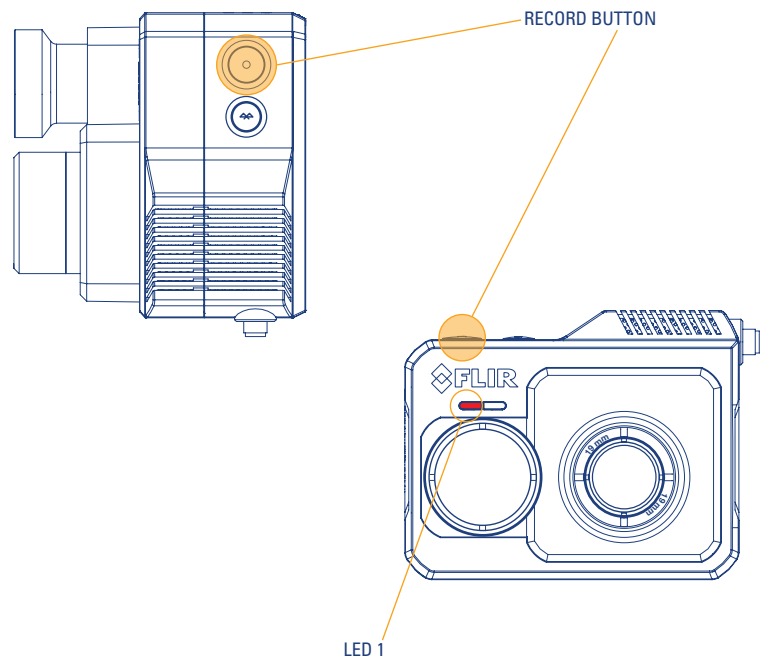

STEP 4: RETRIEVE RECORDINGS

There are two ways to retrieve recorded video & image files from the Duo Pro R:

- Remove the SD cards from the camera and read the files using an SD card reader (included on some laptops).
- With the camera powered through the 10-pin JST connector, connect the camera to a computer using the included USB cable. Note that the camera must be powered through the 10-pin connection, as most computers cannot supply 12W through USB to sufficiently power the Duo Pro R.

STEP 5: ACTIVATING BLUETOOTH

When LED 2 is blue, the camera's Bluetooth is active and you can connect to it via the FLIR UAS mobile app. Bluetooth is enabled upon camera boot up, but automatically disables after two minutes of no activity (LED 2 will turn green). Press the Bluetooth button on the camera at any time to reactivate Bluetooth.

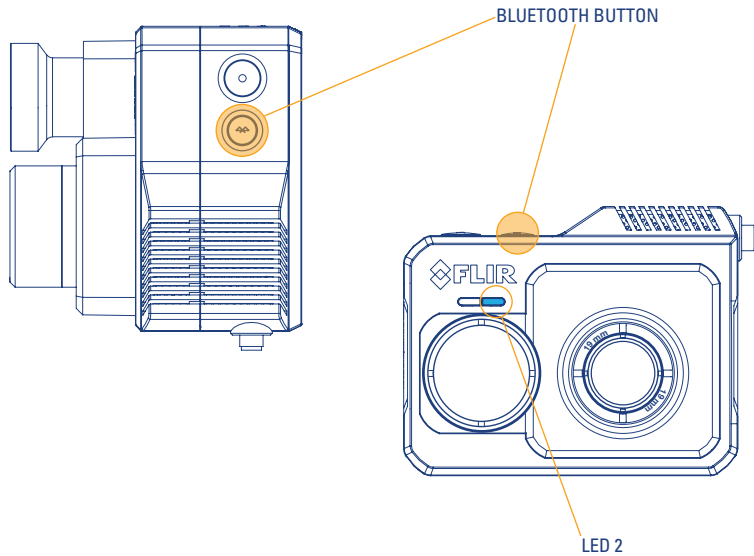

STEP 6: CONNECTING TO CAMERA BLUETOOTH

Download the FLIR UAS mobile app from Google Android Play Store or Apple iOS App Store. This connects to the camera over Bluetooth so that you can change camera settings and start or stop recording remotely. Launch the FLIR UAS app and it will automatically display a list of cameras nearby. Select your Duo Pro R and wait for settings to sync.

- Note that no images are transferred to the phone: all recordings are saved to the onboard SD cards.

STEP 7: CONFIGURE DUO PRO R WITH THE APP

The FLIR UAS app lets you configure many of your camera's functions and options. Here are a few to get you started:

- Choose between Thermal, Visible, and Picture-in-Picture video display modes
- Change the IR color palette to apply different thermal colorization schemes to your infrared images and video.
- Switch between video and still image recording modes.

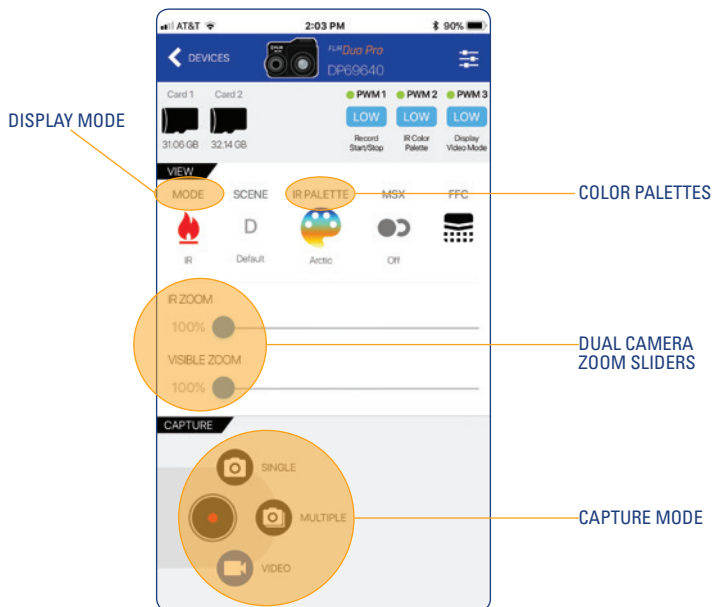

STEP 8: ADVANCED SETTINGS

Press the Settings button on the top-right of the app's main screen to adjust advanced recording features, PWM and MAVLink settings, and to view camera information.

Some of the advanced features you can configure include:

- Radiometric temperature measurement parameters
- Recorded data formats
- Analog video format (NTSC or PAL)
- Camera orientation (if you need to mount camera upside down)
- LED and speaker control

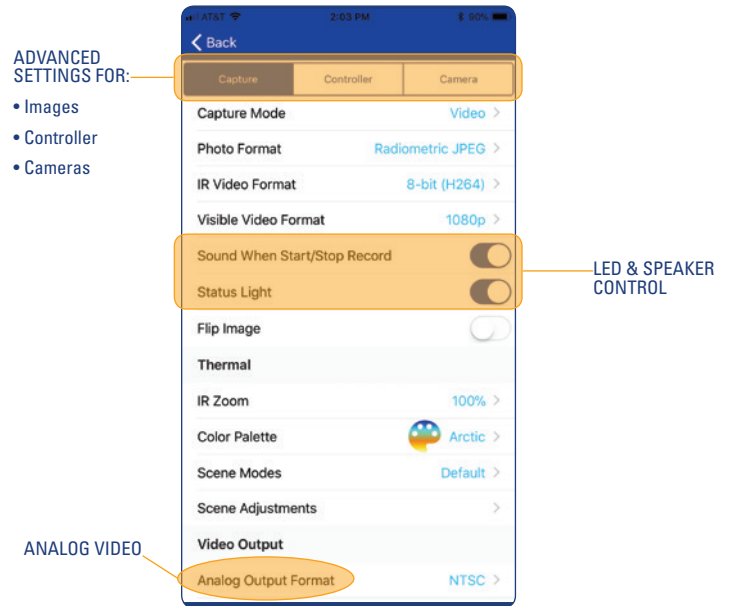

FREQUENTLY ASKED QUESTIONS

My camera keeps turning on and off when I connect it to power. What's wrong?

Ensure that your camera is connected to an adequate power source. Plugging into a computer USB port or a standard cellphone charger does not provide enough power for the Duo Pro R to operate correctly. FLIR recommends a tablet charger capable of at least 12 watts.

Why doesn't my camera connect to the FLIR UAS mobile app?

Verify Bluetooth is enabled – LED 2 should be blue. Press the Bluetooth button on the camera to toggle Bluetooth on and off.

Is there an internal battery?

Duo Pro R does not have an internal battery, as it is designed for lightweight integration platforms that can provide power to the camera, such as small Unmanned Aerial Systems (sUAS) and drones. Evaluate your sUAS for available power connections.

How do I mount on my airframe?

There are two ¼"-20 tripod mounting interfaces on the bottom of the camera. This enables mounting to many commercially-available gimbals.

What are Radiometric JPEG images?

Radiometric JPEG images have temperature data embedded in each pixel, and can be analyzed with FLIR's free FLIR Tools software. FLIR Tools can be used to view infrared, visible, and MSX blended images, as well as to thermally tune images to bring out the details you need.

CORPORATE HEADQUARTERS
FLIR Systems, Inc.
27700 SW Parkway Ave.
Wilsonville, OR 97070
PH: +1 877.773.3547

SANTA BARBARA
FLIR Systems, Inc.
6769 Hollister Ave.
Goleta, CA 93117
PH: +1 805.690.6602

www.flir.com
NASDAQ: FLIR

Equipment described herein is subject to US export regulations and may require a license prior to export. Diversion contrary to US law is prohibited. Imagery for illustration purposes only. Specifications are subject to change without notice. ©2017 FLIR Systems, Inc. All rights reserved. 11/30/17 - 17-3060-OEM