

## P/N: 85206-0102

### Copyright

© 2020, FLIR Systems, Inc.

All rights reserved worldwide. Names and marks appearing herein are either registered trademarks or trademarks of FLIR Systems and/or its subsidiaries. All other trademarks, trade names or company names referenced herein are used for identification only and are the property of their respective owners.

### Document identity

Publ. No.: 85206-0102  
 Commit: 72249  
 Language:  
 Modified: 2020-12-01  
 Formatted: 2020-12-01

### Website

<http://www.flir.com>

### Customer support

<http://support.flir.com>

### Disclaimer

Specifications subject to change without further notice. Camera models and accessories subject to regional market considerations. License procedures may apply. Products described herein may be subject to US Export Regulations. Please refer to [exportquestions@flir.com](mailto:exportquestions@flir.com) with any questions.



General	
<p>The FLIR GF77 is a groundbreaking uncooled optical gas imaging camera with interchangeable lens options that allow you to detect methane, sulfur hexafluoride (SF6), ethylene, and other gas emissions. Capable of gas visualization and radiometric temperature measurement, the FLIR GF77 is an ideal inspection tool for electric power utilities, oil and natural gas operations, chemical/manufacturing facilities, the food, and agriculture industry, and first responders. The FLIR GF77 is compatible with two lens types: the FLIR GF77-LR lens is spectrally filtered for methane and other industry gases, while the FLIR GF77-HR lens is filtered for SF6, ammonia, and more.</p> <p>Based on the award-winning design of the FLIR T-series platform, the FLIR GF77 offers a vibrant, 4-inch touchscreen LCD, 180 degree rotating optical block, and eyepiece for convenience in direct sunlight. This affordable solution offers the benefit of built in thermographic calibrations and the flexibility to visualize multiple gases by simply changing lenses.</p>	
Imaging and optical data	
Infrared resolution	320 x 240 pixels
UltraMax (super-resolution)	Yes
Thermal sensitivity (NETD)	<ul style="list-style-type: none"> <li>&lt; 25 mK, 25° at +30°C (+86°F)</li> <li>&lt; 40 mK, 6° at +30°C (+86°F)</li> </ul>
Gas sensitivity (NECL)	<p>LR lens:</p> <ul style="list-style-type: none"> <li>CH<sub>4</sub>: &lt; 100 ppm x m</li> <li>N<sub>2</sub>O: &lt; 75 ppm x m</li> <li>C<sub>3</sub>H<sub>8</sub>: &lt; 400 ppm x m</li> <li>SO<sub>2</sub>: &lt; 30 ppm x m</li> <li>R-134a: &lt; 20 ppm x m</li> <li>R-152a: &lt; 100 ppm x m</li> </ul> <p>HR lens:</p> <ul style="list-style-type: none"> <li>SF<sub>6</sub>: &lt; 1 ppm x m</li> <li>C<sub>2</sub>H<sub>4</sub>: &lt; 20 ppm x m</li> <li>NH<sub>3</sub>: &lt; 20 ppm x m</li> </ul> <p>(ΔT = 10°C, Distance = 1 m)</p>
Field of view (FOV)	<ul style="list-style-type: none"> <li>25° x 19°</li> <li>6.4° x 4.9°</li> </ul>
Minimum focus distance	<ul style="list-style-type: none"> <li>0.3 m (0.98 ft), 25°</li> <li>5 m (16.4 ft), 6°</li> </ul>



# FLIR GF77 LR 25° (7–8.5 μm) + HR 25° (9.5–12 μm) + HR 6° (9.5–12 μm)

P/N: 85206-0102

© 2020, FLIR Systems, Inc.

#85206-0102; r. 72249;

<b>Imaging and optical data</b>	
Minimum focus distance with MSX	0.65 m (2.1 ft), 25°
Focal length	<ul style="list-style-type: none"><li>• 18 mm (0.71 in), 25°</li><li>• 74 mm (2.9 in), 6°</li></ul>
Spatial resolution (IFOV)	<ul style="list-style-type: none"><li>• 1.4 mrad/pixel, 25°</li><li>• 0.36 mrad/pixel, 6°</li></ul>
Available extra lenses	<ul style="list-style-type: none"><li>• 25° HR (service calibration required)</li></ul>
Lens identification	Automatic
f-number	1.04, 25° 1.35, 6°
Image frequency	30 Hz
Focus	<ul style="list-style-type: none"><li>• Continuous LDM</li><li>• One-shot LDM</li><li>• One-shot contrast</li><li>• Manual</li></ul>
Field of view match	Yes
Digital zoom	1–6× continuous
Lens spectral range	LR: 7–8.5 μm HR: 9.5–12 μm
<b>Detector data</b>	
Focal plane array/spectral range	Uncooled microbolometer/7–14 μm
Detector pitch	25 μm
<b>Image presentation</b>	
Resolution (display)	640 × 480 pixels (VGA)
Surface brightness (cd/m <sup>2</sup> )	400
Screen size	4 in.
Viewing angle	80°
Color depth (bits)	24
Aspect ratio	4:3
Auto-rotation	Yes
Touchscreen	Optically bonded PCAP
Display technology	IPS
Cover glass material	Dragontrail®
Programmable buttons	2
Viewfinder	Yes
Image adjustment	<ul style="list-style-type: none"><li>• Automatic</li><li>• Automatic maximum</li><li>• Automatic minimum</li><li>• HSM</li><li>• Manual</li></ul>



# FLIR GF77 LR 25° (7–8.5 μm) + HR 25° (9.5–12 μm) + HR 6° (9.5–12 μm)

P/N: 85206-0102

© 2020, FLIR Systems, Inc.

#85206-0102; r. 72249;

<b>Image presentation modes</b>	
Infrared image	Yes
Visual image	Yes
MSX	Yes
Picture in picture	Resizable and movable
Gallery	Yes
<b>Measurement</b>	
Camera temperature range	<ul style="list-style-type: none"> <li>• -20 to 80°C (-4 to 176°F)</li> <li>• 0 to 250°C (32 to 482°F)</li> <li>• 100 to 500°C (212 to 932°F)</li> </ul>
Accuracy — for ambient temperature +15 to +35° C (+59 to +95°F)	<ul style="list-style-type: none"> <li>• Range -20 to 80°C (-4 to 176°F): ±3°C (±5.4°F)</li> <li>• Range 0 to 250°C (32 to 482°F):               <ul style="list-style-type: none"> <li>◦ 0 to 100°C (32 to 212°F): ±3°C (±5.4°F)</li> <li>◦ 100 to 250°C (212 to 482°F): ±3%</li> </ul> </li> <li>• Range 100 to 500°C (212 to 932°F): ±3%</li> </ul>
<b>Inspection mode</b>	
FLIR Inspection route	Enabled in the camera
<b>Measurement analysis</b>	
Spotmeter	3 in live mode
Area	3 in live mode
Automatic hot/cold detection	Automatic maximum/minimum markers within area
Measurement presets	<ul style="list-style-type: none"> <li>• No measurements</li> <li>• Center spot</li> <li>• Hot spot</li> <li>• Cold spot</li> <li>• User preset 1</li> <li>• User preset 2</li> </ul>
Difference temperature	Yes
Reference temperature	Yes
Emissivity correction	Yes, variable from 0.01 to 1.0 or selected from materials list
Measurement corrections	Yes
<b>Alarm</b>	
Color alarm (isotherm)	<ul style="list-style-type: none"> <li>• Above</li> <li>• Below</li> <li>• Interval</li> <li>• Condensation (moisture/humidity/dewpoint)</li> <li>• Insulation</li> </ul>
Measurement function alarm	Audible/visual alarms (above/below) on any selected measurement function

P/N: 85206-0102

© 2020, FLIR Systems, Inc.

#85206-0102; r. 72249;

<b>Set-up</b>	
Color palettes	<ul style="list-style-type: none"> <li>• Arctic</li> <li>• White hot</li> <li>• Black hot</li> <li>• Iron</li> <li>• Lava</li> <li>• Rainbow</li> <li>• Rainbow HC</li> </ul>
Setup commands	Local adaptation of units, language, date, and time formats
Languages	21
<b>Service functions</b>	
Camera software update	Using USB cable or SD card
<b>Storage of images</b>	
Storage media	Removable memory: SD card
Time lapse (Periodic image storage)	10 seconds to 24 hours (infrared)
Remote control operation	Using USB cable or Wi-Fi
Image file format	Standard JPEG, measurement data included. Infrared-only mode
<b>Image annotations</b>	
Voice	60 seconds with built-in microphone and speaker (and via Bluetooth) on still images and video
Text	Text from predefined list or soft keyboard on touchscreen
Visual image annotation	Yes
Image sketch	Yes: on infrared only
Sketch	From touchscreen
METERLiNK	Wireless connection (Bluetooth) to: FLIR meters with METERLiNK
Compass	Yes
Laser distance meter information	Yes
Area measurement information	Yes
GPS	Location data automatically added to every still image and first frame in video from built-in GPS
<b>Video recording in camera</b>	
Radiometric infrared-video recording	RTRR (.csq)
Non-radiometric infrared-video recording	H.264 to memory card
Visual video recording	H.264 to memory card



# FLIR GF77 LR 25° (7–8.5 μm) + HR 25° (9.5–12 μm) + HR 6° (9.5–12 μm)

P/N: 85206-0102

© 2020, FLIR Systems, Inc.

#85206-0102; r. 72249;

<b>Video streaming</b>	
Radiometric infrared-video streaming (compressed)	Over UVC
Non-radiometric video streaming (compressed: IR, MSX, visual, Picture in Picture)	<ul style="list-style-type: none"> <li>• H.264 (AVC) over RTSP (Wi-Fi)</li> <li>• MPEG4 over RTSP (Wi-Fi)</li> <li>• MJPEG over UVC and RTSP (Wi-Fi)</li> </ul>
Visual video streaming	Yes
<b>Digital camera</b>	
Resolution	5 MP with LED light
Focus	Fixed
Field of view	53° × 41°
Video lamp	Built-in LED light
<b>Laser pointer</b>	
Laser alignment	Position is automatically displayed on the infrared image
Laser distance meter	Activated by dedicated button
Laser	Class 2, 0.05–40 m (0.16–131 ft) ±1% of measured distance
<b>Data communication interfaces</b>	
Interfaces	USB 2.0, Bluetooth, Wi-Fi, DisplayPort
METERLiNK/Bluetooth	Communication with headset and external sensors
Wi-Fi	Peer to peer (ad hoc) or infrastructure (network)
Audio	Microphone and speaker for voice annotation of images
USB	USB Type-C: data transfer/video/power
USB standard	USB 2.0 High Speed
Video out	DisplayPort
Video connector type	DisplayPort over USB Type-C
<b>Radio</b>	
Operating frequency	Bluetooth + EDR/LE: 2402–2480 MHz WLAN 2.4 GHz: 2412–2462 MHz WLAN 5 GHz: 5150–5350 MHz (DFS: only slave mode) Note that frequency band 5150–5350 MHz is for indoor use only, see national regulations.
RF output (EIRP)	Bluetooth + EDR/LE: < 10 dBm WLAN: < 17 dBm
Antenna	Integrated PIFA antenna (gain: maximum 1.4 dBi)
<b>Power system</b>	
Battery type	Rechargeable Li-ion battery
Battery voltage	3.6 V
Battery operating time	> 4 hours at 25°C (68°F) with typical use



# FLIR GF77 LR 25° (7–8.5 μm) + HR 25° (9.5–12 μm) + HR 6° (9.5–12 μm)

P/N: 85206-0102

© 2020, FLIR Systems, Inc.

#85206-0102; r. 72249;

<b>Power system</b>	
Charging system	In camera (AC adapter or 12 V from a vehicle) or two-bay charger
Charging time (using two-bay charger)	3.5 h to 90% capacity, on-screen indicator
Charging temperature	0°C to +45°C (+32°F to +113°F), except for the Korean market: +10°C to +45°C (+50°F to +113°F)
External power operation	AC adapter 90–260 V AC (50/60 Hz) or 12 V from a vehicle (cable with standard plug, optional)
Power management	Automatic shut-down and sleep mode
<b>Environmental data</b>	
Operating temperature range	–15 to +50°C (5 to +122°F)
Storage temperature range	–40 to +70°C (–40 to 158°F)
Humidity (operating and storage)	IEC 60068-2-30/24 hours, 95% relative humidity, 25–40°C (77–104°F)/2 cycles
EMC	<ul style="list-style-type: none"> <li>• ETSI EN 301 489-1 (radio)</li> <li>• ETSI EN 301 489-17</li> <li>• EN 61000-6-2 (immunity)</li> <li>• EN 61000-6-3 (emission)</li> <li>• FCC 47 CFR part 15 B, class B (emission)</li> </ul>
Radio spectrum	<ul style="list-style-type: none"> <li>• ETSI EN 300 328</li> <li>• ETSI EN 301 893</li> <li>• FCC 47 CFR part 15 C</li> <li>• FCC 47 CFR part 15 E</li> </ul>
Encapsulation	IP 54 (IEC 60529)
Shock	25g (IEC 60068-2-27)
Vibration	2g (IEC 60068-2-6)
Safety	Camera: <ul style="list-style-type: none"> <li>• IEC/EN 60950-1, IEC/EN 62368-1</li> </ul> Power supply: <ul style="list-style-type: none"> <li>• IEC/EN 62368-1</li> <li>• CSA/UL/KC/SAA/PSE 60950-1</li> </ul>
<b>Physical data</b>	
Weight (including battery)	1.4 kg (3.1 lb)
Size (L × W × H)	Camera with 25° lens: <ul style="list-style-type: none"> <li>• Lens vertical: 150.5 × 201.3 × 84.1 mm (5.9 × 7.9 × 3.3 in)</li> <li>• Lens horizontal: 150.5 × 201.3 × 167.3 mm (5.9 × 7.9 × 6.6 in)</li> </ul> Camera with 6° lens: <ul style="list-style-type: none"> <li>• Lens vertical: 204.6 × 201.3 × 84.1 mm (8.1 × 7.9 × 3.3 in)</li> <li>• Lens horizontal: 150.5 × 201.3 × 167.3 mm (5.9 × 7.9 × 6.6 in)</li> </ul>
Battery weight	195 g (6.89 oz)
Battery size (L × W × H)	59 × 66 × 94 mm (2.3 × 2.6 × 3.7 in)
Tripod mounting	UNC ¼"-20

P/N: 85206-0102

© 2020, FLIR Systems, Inc.

#85206-0102; r. 72249;

<b>Physical data</b>	
Housing material	PCABS with TPE, magnesium
Color	Black
<b>Warranty and service</b>	
Warranty	<a href="http://www.flir.com/warranty/">http://www.flir.com/warranty/</a>
<b>Shipping information</b>	
Packaging, type	Cardboard box
Packaging, contents	<ul style="list-style-type: none"> <li>• Accessory box I: <ul style="list-style-type: none"> <li>◦ Power supply for battery charger</li> <li>◦ Power supply, 15 W/3 A</li> <li>◦ Printed documentation</li> <li>◦ SD card (8 GB)</li> <li>◦ USB 2.0 A to USB Type-C cable</li> <li>◦ USB Type-C to HDMI and PD adapter</li> <li>◦ USB Type-C to USB Type-C cable (USB 2.0 standard)</li> </ul> </li> <li>• Accessory box II: <ul style="list-style-type: none"> <li>◦ Lens cap strap</li> <li>◦ Lens cleaning cloth</li> <li>◦ Neck strap</li> <li>◦ Small eyecup</li> </ul> </li> <li>• Battery (2 ea)</li> <li>• Battery charger</li> <li>• Hard transport case</li> <li>• Infrared camera</li> <li>• Lens cap, front</li> <li>• Lens cap, front and rear (only for extra lenses)</li> <li>• Lens, HR 25°</li> <li>• Lens, HR 6°</li> <li>• Lens, LR 25°</li> </ul>
Packaging, weight	6.3 kg (13.9 lb)
Packaging, size	500 × 190 × 370 mm (19.7 × 7.5 × 14.6 in)
EAN-13	7332558027172
UPC-12	845188023249
Country of origin	Sweden

### Supplies & accessories:

- T300112; IR lens HR 6° (9.5–12 μm) with case
- T300114; IR lens HR 25° (9.5–12 μm) with case
- T300115; IR lens LR 25° (7–8.5 μm) with case
- T300129; IR lens LR 6° (7–8.5 μm) with case
- T199300ACC; Battery
- T199347ACC; Hard transport case for FLIR T8xx, T5xx, and GF7x series
- T199610; Battery charger
- T130531ACC; Large eyecup
- T300178; Hand strap and neck strap
- T911630ACC; Power supply for camera, 15 W/3 A
- T911631ACC; USB 2.0 A to USB Type-C cable, 0.9 m
- T911633ACC; Power supply for battery charger
- T911705ACC; USB Type-C to USB Type-C cable (USB 2.0 standard), 1.0 m
- T911706ACC; Car adapter 12 V



## FLIR GF77 LR 25° (7–8.5 μm) + HR 25° (9.5–12 μm) + HR 6° (9.5–12 μm)

---

**P/N: 85206-0102**

© 2020, FLIR Systems, Inc.

#85206-0102; r. 72249;

- T911845ACC; USB Type-C to HDMI and PD adapter
- T911846ACC; USB 2.0 A to USB Type-C with Power supply
- T198495; Pouch
- T197771ACC; Bluetooth Headset
- T300243; FLIR Thermal Studio Pro, 1 Year Subscription
- T300083; FLIR Thermal Studio Pro, Perpetual license
- T300341; FLIR Thermal Studio Standard, 1 Year Subscription
- T300258; FLIR Thermal Studio Standard, Perpetual license
- T198583; FLIR Tools+ (download card incl. license key)
- T198696; FLIR ResearchIR Max 4 (hardware sec. dev.)
- T199013; FLIR ResearchIR Max 4 (printed license key)
- T199043; FLIR ResearchIR Max 4 Upgrade (printed license key)
- INST-EW-0170; Extended Warranty 1 Year for T10xx, GF7x
- INST-EWGM-0180; Premium Service Package for A310pt, T10xx, GF7x
- INST-GM-0160; General Maintenance Package for T10xx, GF7x, P6xx, X90, SC1000



# Camera housing

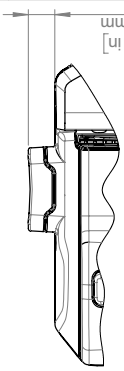
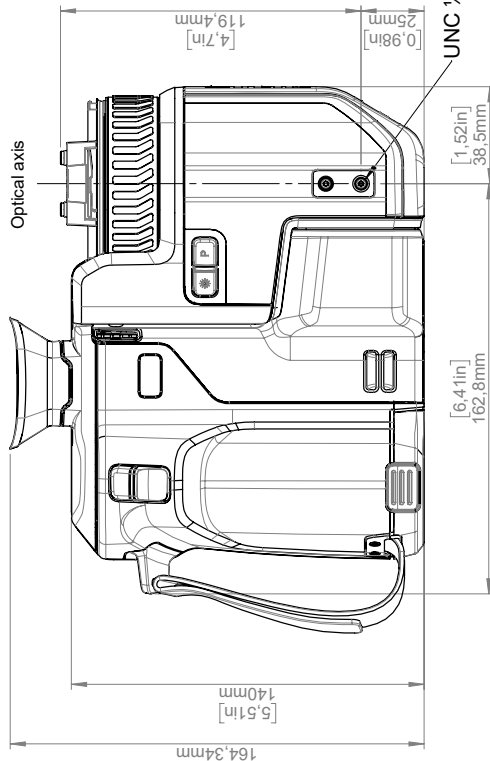
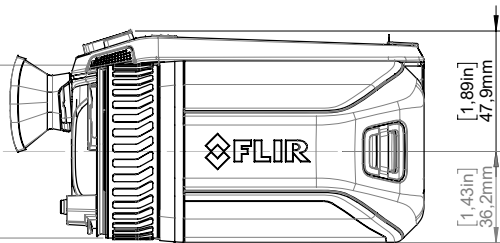
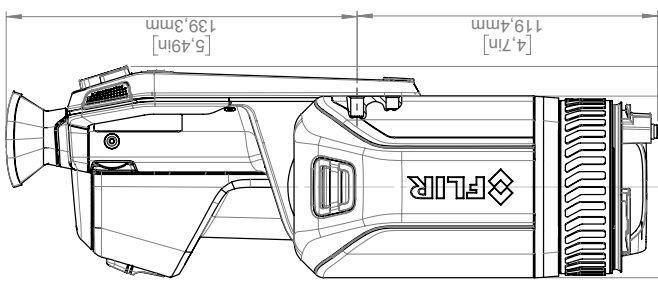
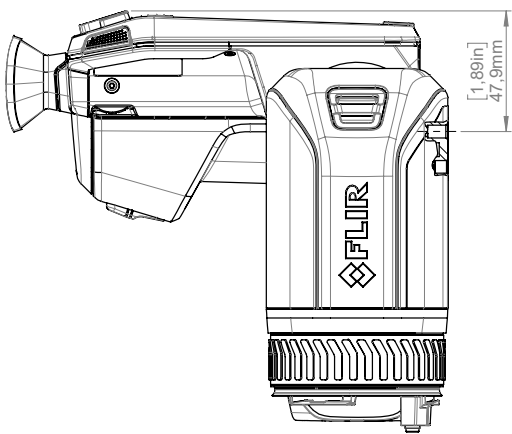
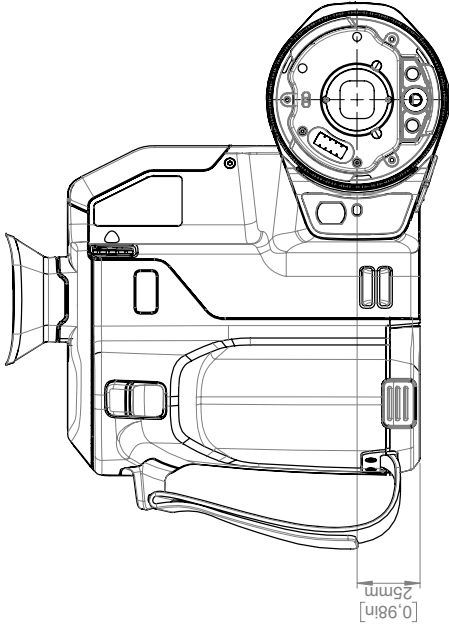
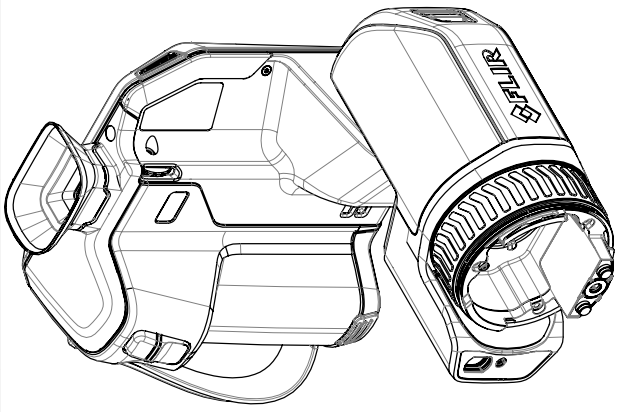

		Size <b>A3</b>	Drawn by R&D Instruments
Modified 2019-09-30	Check -	Scale 1:2	Drawing No. T130694
Denomination <b>Basic dimensions FLIR GF7x</b>			Sheet 1(4)
			Rev B

©2016, FLIR Systems, Inc. All rights reserved worldwide. No part of this drawing may be reproduced, stored in a retrieval system, or transmitted in any form, or by any means, electronic, mechanical, photocopying, recording, or otherwise, without written permission from FLIR Systems, Inc. Specifications subject to change without further notice. Dimensional data is based on nominal values. Products may be subject to regional market considerations, license procedures may apply. Product may be subject to US Export Regulations. Please refer to exportquestions@flir.com with any questions. Diversion contrary to US law is prohibited.

# Camera with Lens IR f=18mm (25°)

© 2016, FLIR Systems, Inc. All rights reserved worldwide. No part of this drawing may be reproduced, stored in a retrieval system, or transmitted in any form, or by any means, electronic, mechanical, photocopying, recording, or otherwise, without written permission from FLIR Systems, Inc. Specifications subject to change without further notice. Dimensional data is based on nominal values. Products may be subject to regional market considerations. License procedures may apply. Product may be subject to US Export Regulations. Please refer to exportquestions@flir.com with any questions. Diversion contrary to US law is prohibited.

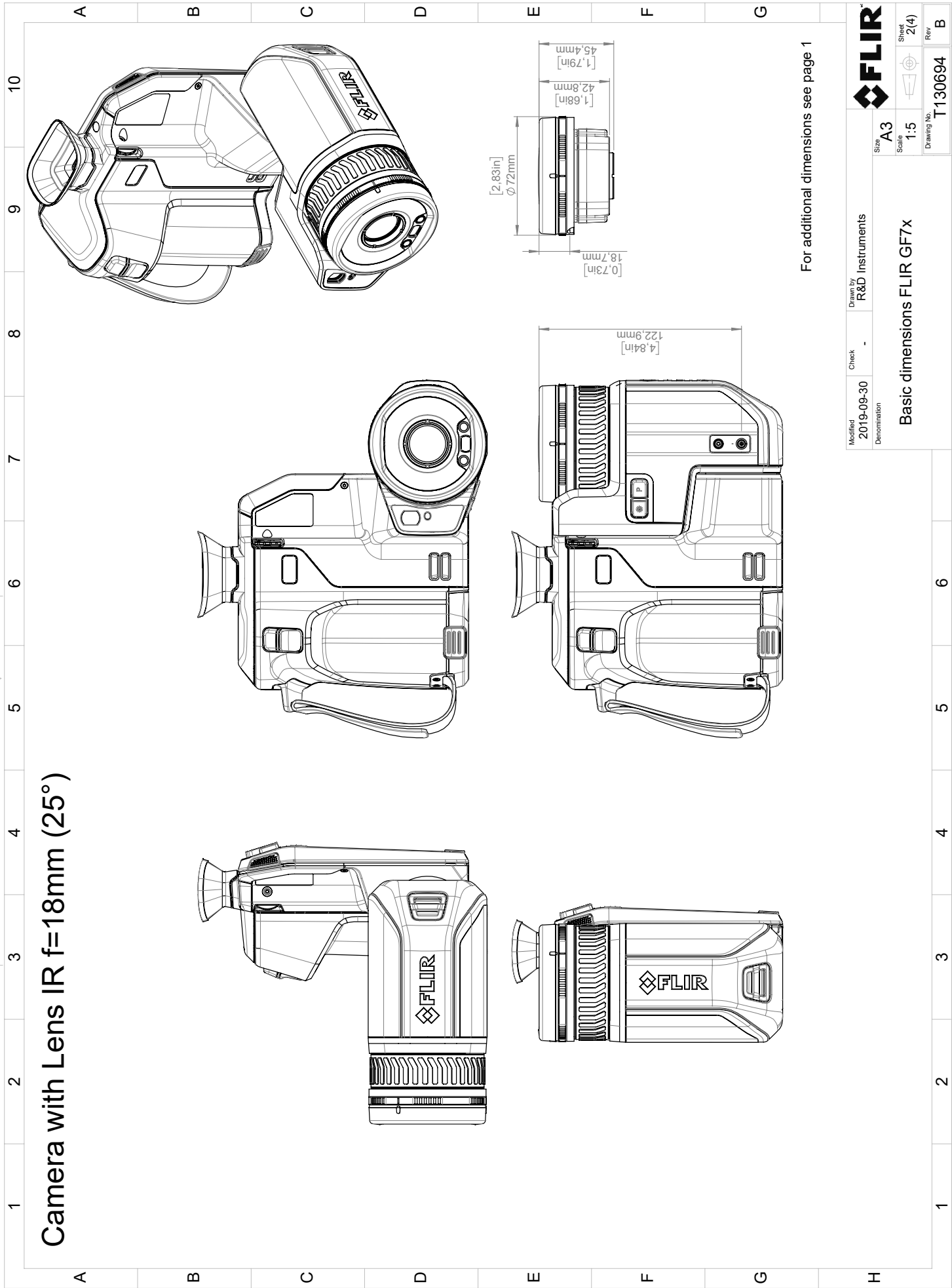

For additional dimensions see page 1

Modified 2019-09-30	Check -	Drawn by R&D Instruments	<b>FLIR</b>
Denomination Basic dimensions FLIR GF7x		Size A3	Sheet 2(4)
		Scale 1:5	Rev
		Drawing No. T130694	B

# Camera with Lens IR f=74mm (6°)

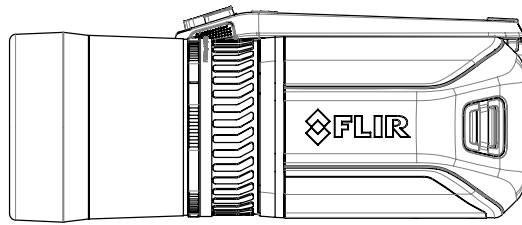
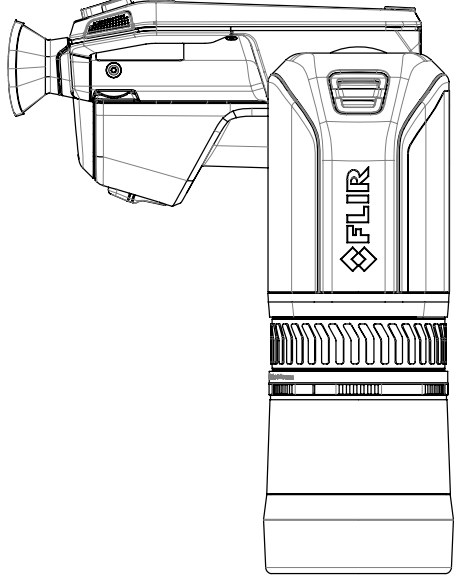
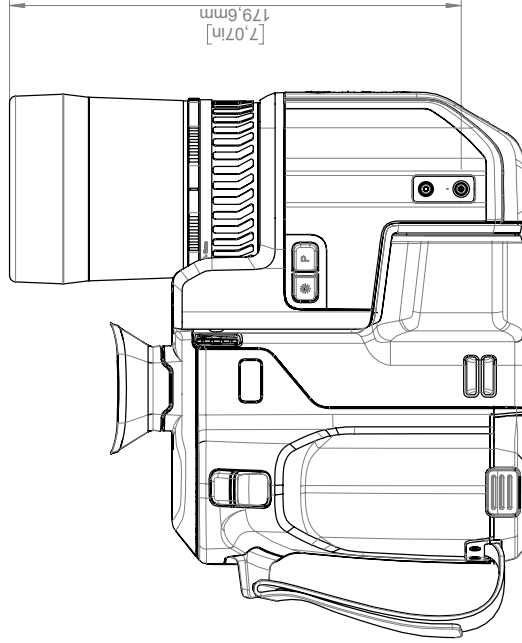
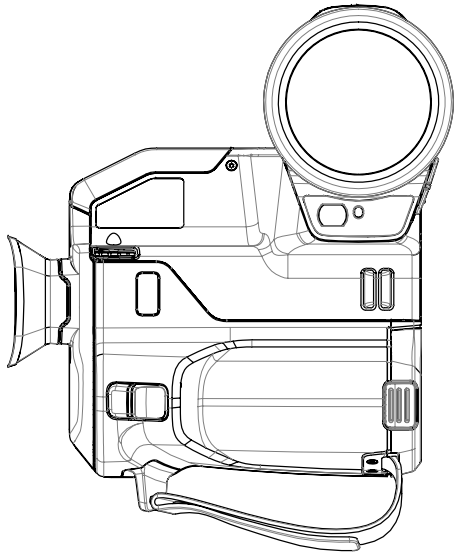
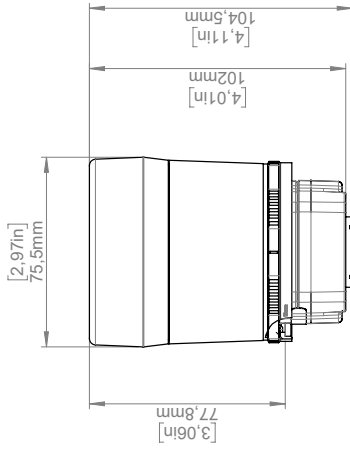
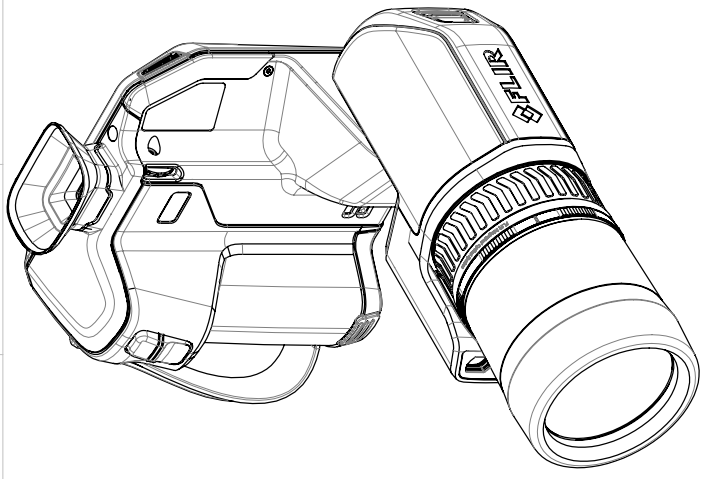

For additional dimensions see page 1

© 2016, FLIR Systems, Inc. All rights reserved worldwide. No part of this drawing may be reproduced, stored in a retrieval system, or transmitted in any form, or by any means, electronic, mechanical, photocopying, recording, or otherwise, without written permission from FLIR Systems, Inc. Specifications subject to change without further notice. Dimensional data is based on nominal values. Products may be subject to regional market considerations. License procedures may apply. Product may be subject to US Export Regulations. Please refer to exportquestions@flir.com with any questions. Diversion contrary to US law is prohibited.

Modified 2019-09-30	Check	Drawn by R&D Instruments	<b>FLIR</b>
Denomination			Sheet 3(4)
Basic dimensions FLIR GF7x			Size A3
			Scale 1:5
			Drawing No. T130694
			Rev B

# Battery Charger

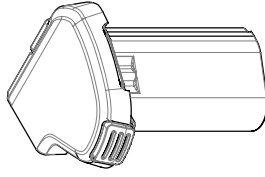
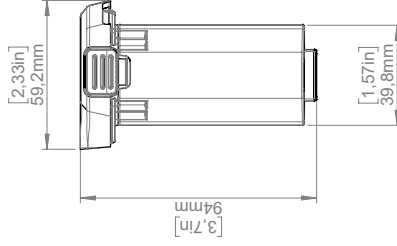
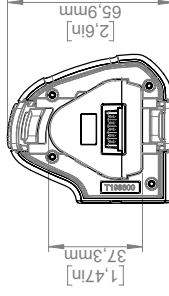
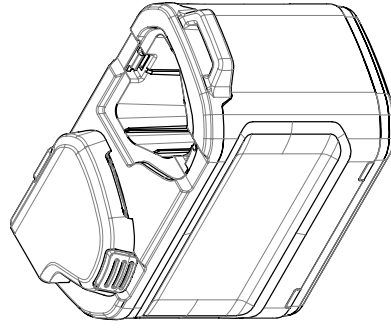
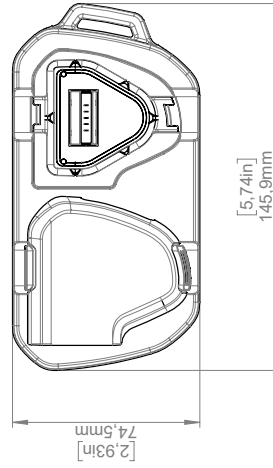
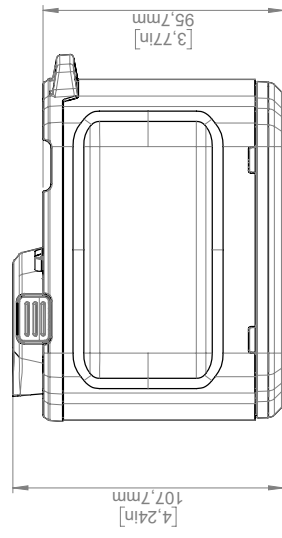

© 2016, FLIR Systems, Inc. All rights reserved worldwide. No part of this drawing may be reproduced, stored in a retrieval system, or transmitted in any form, or by any means, electronic, mechanical, photocopying, recording, or otherwise, without written permission from FLIR Systems, Inc. Specifications subject to change without further notice. Dimensional data is based on nominal values. Products may be subject to regional market considerations. License procedures may apply. Product may be subject to US Export Regulations. Please refer to exportquestions@flir.com with any questions. Diversion contrary to US law is prohibited.

Modified 2019-09-30	Check -	Drawn by R&D Instruments	<b>FLIR</b>
Denomination	Size A3	Scale 1:5	Sheet 4(4)
Basic dimensions FLIR GF7x			Rev T130694
			B



The World's Sixth Sense™

February 2, 2019 Täby, Sweden

AQ320246

### CE Declaration of Conformity – EU Declaration of Conformity

Product: FLIR T5XX-, T8XX- and GF7X-series

Name and address of the manufacturer:

FLIR Systems AB

PO Box 7376

SE-187 15 Täby, Sweden

This declaration of conformity is issued under the sole responsibility of the manufacturer.

The object of the declaration: FLIR T5XX-, T8XX- and GF7X-series (Product Model Name FLIR-T8210).

The object of the declaration described above is in conformity with the relevant Union harmonisation legislation:

#### Directives:

Directive	2012/19/EU	Waste electrical and electric equipment
Directive	2014/53/EU	Radio Equipment Directive (RED)
Directive	1999/519/EC	Limitation of exposure to electromagnetic fields (SAR)
Directive	2011/65/EU	RoHS and 2015/830/EU

#### Standards:

EMC Radio:	ETSI EN 301 489-1 + -17	EMC for radio, broadband data transmission
Emission:	EN 61000-6-3/A1:2011	EMC – Generic standards
Immunity:	EN 61000-6-2:2005	Electromagnetic Compability Generic
	EN 301489-1:2016 v2.1.0	ERM – EMC for radio equipment
	EN 301489-17:2012 v2.2.1	ERM – EMC Wideband data
Laser:	EN 60825-1	Safety of laser products
Radio:	ETSI EN 300 328 v2.1.1	Harmonized EN covering essential requirements of the R&TTE Directive
	ETSI EN 301 893 v.2.1.1	5GHz WLAN
	EN 303 413 v1.1.0	Radio Spectrum Efficiency (gps)
SAR:	EN 50566:2013/AC:2014	Handheld and body mounted wireless
	EN 62209-02:2010	Handheld and body mounted wireless
Safety:	IEC 60950-1:2005+A1:2009+	Information technology equipment
	A2:2013 EN 60950-1:2006+	
	A11:2009+AC:2011+A12:2011	
RoHS:	EN 50581:2012	Technical documentation

**FLIR Systems AB**

Quality Assurance

Lea Dabiri

Quality Manager