

P/N: 79303-0302

Copyright

© 2021, FLIR Systems, Inc.

All rights reserved worldwide. Names and marks appearing herein are either registered trademarks or trademarks of FLIR Systems and/or its subsidiaries. All other trademarks, trade names or company names referenced herein are used for identification only and are the property of their respective owners.

Document identity

Publ. No.: 79303-0302

Commit: 72831

Language:

Modified: 2020-12-18

Formatted: 2021-07-08

Website

<http://www.flir.com>

Customer support

<http://support.flir.com>

Disclaimer

Specifications subject to change without further notice. Camera models and accessories subject to regional market considerations. License procedures may apply. Products described herein may be subject to US Export Regulations. Please refer to exportquestions@flir.com with any questions.



General	
The following options are enabled on this camera:	
<ul style="list-style-type: none"> Option, Dual streaming Option, Auto-screening 	
Imaging and optical data	
Infrared resolution	464 × 348 pixels
UltraMax (super-resolution) ¹	Yes
NETD	<30 mK @ 30°C (86°F)
Field of view	42° × 32°
Minimum focus distance	0.15 m (0.49 ft)
Minimum focus distance with MSX	0.65 m (2.13 ft)
Focal length	10 mm (0.39 in)
Spatial resolution (IFOV)	1.66 mrad/pixel
Lens identification	Automatic
f number	1.1
Image frequency	30 Hz
Focus	<ul style="list-style-type: none"> Continuous LDM One-shot LDM One-shot contrast Manual
Field of view match	Yes
Digital zoom	1–6× continuous
Detector data	
Focal plane array/spectral range	Uncooled microbolometer/7.5–14 μm
Detector pitch	17 μm
Image presentation	
Resolution	640 × 480 pixels (VGA)
Surface brightness (cd/m ²)	400

1. Not supported when using macro.

P/N: 79303-0302

© 2021, FLIR Systems, Inc.

#79303-0302; r. 72831;

Image presentation	
Screen size	4 in
Viewing angle	80°
Color depth (bits)	24
Aspect ratio	4:3
Auto-rotation	Yes
Touchscreen	Optically bonded PCAP
Display technology	IPS
Cover glass material	Dragontrail®
Programmable buttons	2
Viewfinder	No
Image adjustment	<ul style="list-style-type: none"> • Automatic • Automatic maximum • Automatic minimum • Manual
Image presentation modes	
Infrared image	Yes
Visual image	Yes
MSX	Yes
Picture in picture	Resizable and movable
Gallery	Yes
Measurement	
Camera temperature range	15 to 45°C (59 to 113°F) Accuracy ±0.3°C (±0.5°F) when used in Screening mode The camera will provide contrast from -20 to 120 °C (-4 to 248°F), but no temperature information will be provided
Alarm	
Color alarm (isotherm)	<ul style="list-style-type: none"> • Above
Measurement function alarm	Audible/visual alarms (above/below) on any selected measurement function
Set-up	
Color palettes	<ul style="list-style-type: none"> • Arctic • White hot • Black hot • Iron • Lava • Rainbow • Rainbow HC
Setup commands	Local adaptation of units, language, date, and time formats
Languages	21
Service functions	
Camera software update	Using USB cable or SD card
Storage of images	
Storage media	Removable memory: SD card
Time lapse (Periodic image storage)	10 seconds to 24 hours (infrared)

P/N: 79303-0302

© 2021, FLIR Systems, Inc.

#79303-0302; r. 72831;

Storage of images	
Remote control operation	Using USB cable or Wi-Fi
Image file format	Standard JPEG, measurement data included. Infrared-only mode
Image annotations	
Voice	60 seconds with built-in microphone and speaker (and via Bluetooth) on still images and video
Visual image annotation	Yes
Image sketch	Yes: on infrared only
Sketch	From touchscreen
METERLiNK	Wireless connection (Bluetooth) to: FLIR meters with METERLiNK
GPS	Location data automatically added to every still image and first frame in video from built-in GPS
Video recording in camera	
Radiometric infrared-video recording	RTRR (.csq)
Non-radiometric infrared-video recording	H.264 to memory card
Visual video recording	H.264 to memory card
Video streaming	
Radiometric infrared-video streaming (compressed)	Over UVC
Non-radiometric video streaming (compressed: IR, MSX, visual, Picture in Picture)	<ul style="list-style-type: none"> • H.264 (AVC) over RTSP (Wi-Fi) • MPEG4 over RTSP (Wi-Fi) • MJPEG over UVC and RTSP (Wi-Fi)
Visual video streaming	Yes
Digital camera	
Resolution	5 MP with LED light
Focus	Fixed
Field of view	53° × 41°
Video lamp	Built-in LED light
Laser pointer	
Laser pointer	Yes ²
Laser alignment	Position is automatically displayed on the infrared image
Laser distance meter	Activated by dedicated button
Laser	Class 2, 0.05–40 m (0.16–131 ft) ±1% of measured distance
Data communication interfaces	
Interfaces	USB 2.0, Bluetooth, Wi-Fi, DisplayPort
METERLiNK/Bluetooth	Communication with headset and external sensors
Wi-Fi	Peer to peer (ad hoc) or infrastructure (network)
Audio	Microphone and speaker for voice annotation of images

2. Laser pointer is disabled in Screening mode.

P/N: 79303-0302

© 2021, FLIR Systems, Inc.

#79303-0302; r. 72831;

Data communication interfaces	
USB	USB Type-C: data transfer/video/power
USB standard	USB 2.0 High Speed
Video out	DisplayPort
Video connector type	DisplayPort over USB Type-C
Radio	
Operating frequency	Bluetooth + EDR/LE: 2402–2480 MHz WLAN 2.4 GHz: 2412–2462 MHz WLAN 5 GHz: 5150–5350 MHz (DFS: only slave mode) Note that frequency band 5150–5350 MHz is for indoor use only, see national regulations.
RF output (EIRP)	Bluetooth + EDR/LE: < 10 dBm WLAN: < 17 dBm
Antenna	Integrated PIFA antenna (gain: maximum 1.4 dBi)
Power system	
Battery type	Rechargeable Li-ion battery
Battery voltage	3.6 V
Battery operating time	> 4 hours at 25°C (77°F) with typical use
Charging system	In camera (AC adapter or 12 V from a vehicle) or two-bay charger
Charging time (using two-bay charger)	3.5 h to 90% capacity, on-screen indicator
Charging temperature	0°C to 45°C (32°F to 113°F), except for the Korean market: 10°C to 45°C (50°F to 113°F)
External power operation	AC adapter 90–260 V AC (50/60 Hz) or 12 V from a vehicle (cable with standard plug, optional)
Power management	Automatic shut-down and sleep mode
Environmental data	
Operating temperature range	–15 to 50°C (5–122°F)
Storage temperature range	–40 to 70°C (–40 to 158°F)
Humidity (operating and storage)	IEC 60068-2-30/24 hours, 95% relative humidity, 25–40°C (77–104°F)/2 cycles
EMC	<ul style="list-style-type: none"> • ETSI EN 301 489-1 (radio) • ETSI EN 301 489-17 • EN 61000-6-2 (immunity) • EN 61000-6-3 (emission) • FCC 47 CFR part 15 B, class B (emission)
Radio spectrum	<ul style="list-style-type: none"> • ETSI EN 300 328 • ETSI EN 301 893 • FCC 47 CFR part 15 C • FCC 47 CFR part 15 E
Encapsulation	IP 54 (IEC 60529)
Shock	25g (IEC 60068-2-27)

P/N: 79303-0302

© 2021, FLIR Systems, Inc.

#79303-0302; r. 72831;

Environmental data	
Vibration	2g (IEC 60068-2-6)
Safety	Camera: <ul style="list-style-type: none"> IEC/EN 60950-1, IEC/EN 62368-1 Power supply: <ul style="list-style-type: none"> IEC/EN 62368-1 CSA/UL/KC/SAA/PSE 60950-1
Physical data	
Weight (including battery)	1.3 kg (2.9 lb)
Size (L × W × H)	<ul style="list-style-type: none"> Lens vertical: 140 × 201.3 × 84.1 mm (5.5 × 7.9 × 3.3 in) Lens horizontal: 140 × 201.3 × 167.3 mm (5.5 × 7.9 × 6.6 in)
Battery weight	195 g (6.89 oz)
Battery size (L × W × H)	59 × 66 × 94 mm (2.3 × 2.6 × 3.7 in)
Tripod mounting	UNC ¼"-20
Housing material	PCABS with TPE, magnesium
Color	Black
Warranty and service	
Warranty	http://www.flir.com/warranty/
Shipping information	
Packaging, type	Cardboard box
Packaging, contents	<ul style="list-style-type: none"> Accessory box I: <ul style="list-style-type: none"> Power supply for battery charger Power supply, 15 W/3 A Printed documentation Remote operation button SD card (8 GB) USB 2.0 A to USB Type-C cable USB 2.0 A to USB Type-C cable with Power supply USB Type-C to HDMI and PD adapter USB Type-C to USB Type-C cable (USB 2.0 standard) Accessory box II: <ul style="list-style-type: none"> Lens cap strap Lens cleaning cloth Neck strap Battery (2 ea) Battery charger Hard transport case Infrared camera with lens Lens cap, front Lens cap, front and rear (only for extra lenses)
Packaging, weight	5.8 kg (12.8 lb)
Packaging, size	500 × 190 × 370 mm (19.7 × 7.5 × 14.6 in)
EAN-13	7332558026991
UPC-12	845188023034
Country of origin	Sweden

Supplies and accessories:

- T131171ACC; Remote operation button



FLIR T540-EST 42°

P/N: 79303-0302

© 2021, FLIR Systems, Inc.

#79303-0302; r. 72831;

- T131177; Roll-up, Backdrop for screening
- T131178; Floor sticker, Direction arrow (5 pcs)
- T131179; Floor sticker, Queue markers (5 pcs)
- T131180; Floor sticker, Flexible position for screening
- T131181; Floor sticker, Position for screening
- T199300ACC; Battery
- T199347ACC; Hard transport case for FLIR T8xx, T5xx, and GF7x series
- T199601; Hand strap and neck strap
- T199610; Battery charger
- T300030; Option, No radio
- T300366; Roll-up and stickers kit for screening
- T911997; Tripod
- T911998; HDMI 2-port video splitter
- T300369; Mounting kit (FLIR T5xx, T8xx, Exx)
- T130337ACC; Calibration target
- T911630ACC; Power supply for camera, 15 W/3 A
- T911631ACC; USB 2.0 A to USB Type-C cable, 0.9 m
- T911633ACC; Power supply for battery charger
- T911705ACC; USB Type-C to USB Type-C cable (USB 2.0 standard), 1.0 m
- T911706ACC; Car adapter 12 V
- T911845ACC; USB Type-C to HDMI and PD adapter
- T911846ACC; USB 2.0 A to USB Type-C with Power supply
- T199589; IR lens, f=17 mm (24°) with case
- T199590; IR lens, f=10 mm (42°) with case
- T198495; Pouch
- T300342; FLIR Screen-EST, Perpetual license
- INST-EW-0155; Extended Warranty 1 Year for A3xxf, T540, T600/bx, T610, T840, T860
- INST-EWGM-0165; Premium Service Package for T540, T600/bx, T610, T840, T860
- INST-GM-0150; General Maintenance Package for T540, T6xx, T840, T860

Camera housing

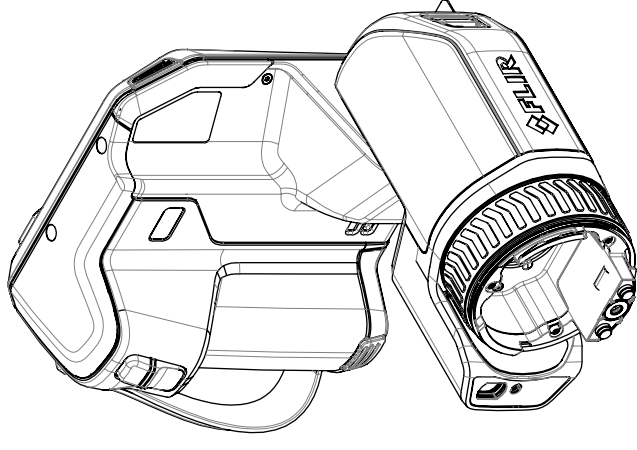
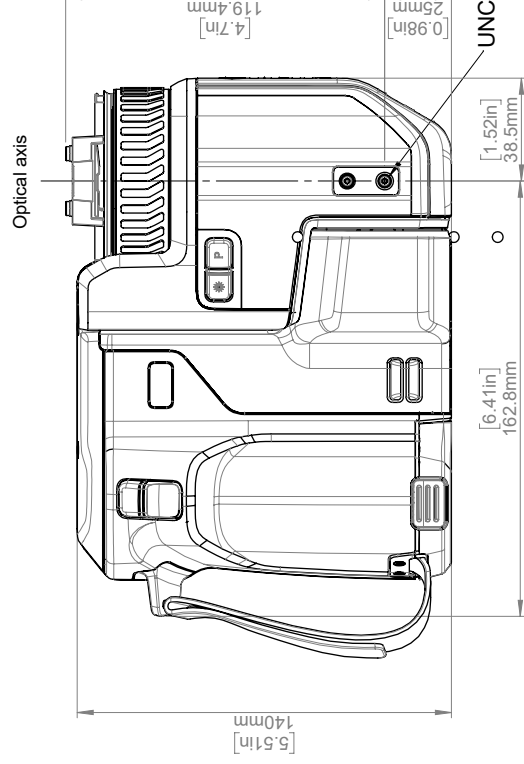
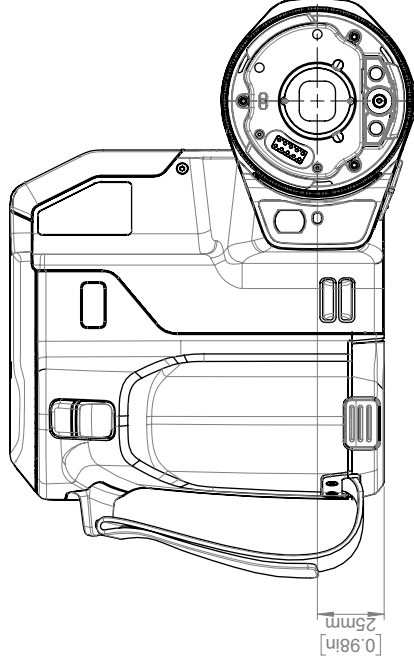
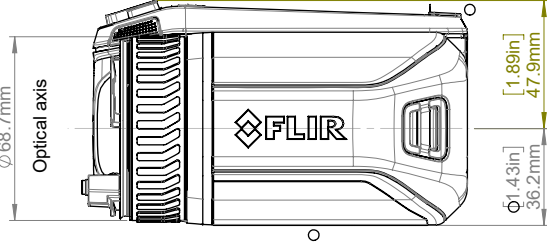
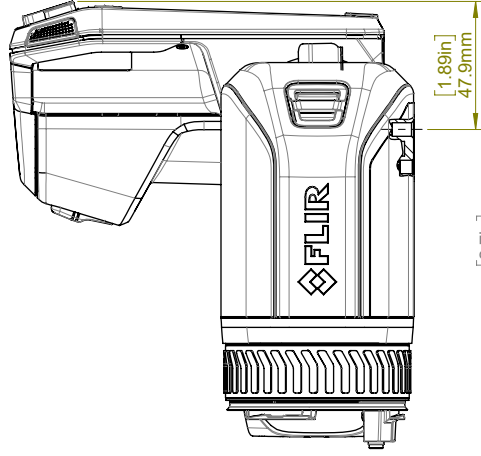
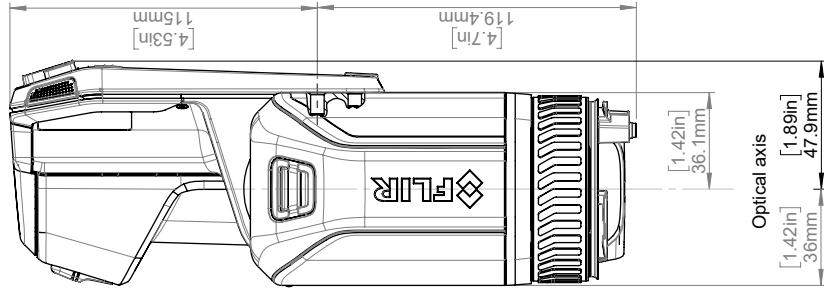

Modified 2020-01-14 Denomination	Check JOHE	Drawn by R&D Instruments	FLIR
Size A3			Sheet 1(4)
Scale 1:2			Rev B
Drawing No. T129991			
Basic dimensions FLIR T5xx			

Camera with Lens IR f=10mm (42°)
 Camera with Lens IR f=17mm (24°)
 Camera with Lens IR f=29mm (14°)
 Camera with Lens IR Close-up 2x

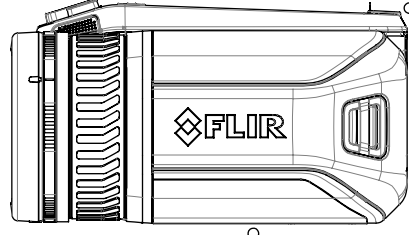
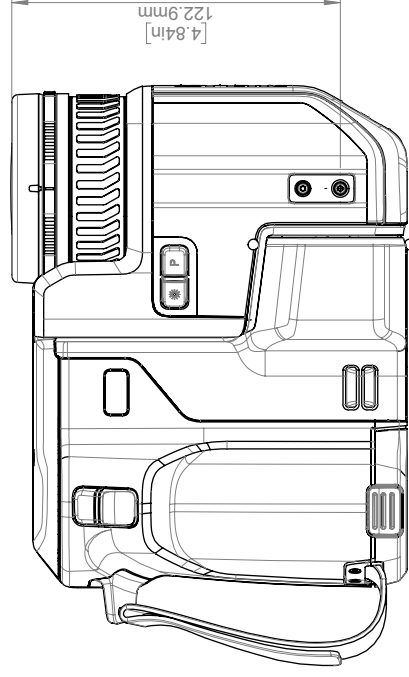
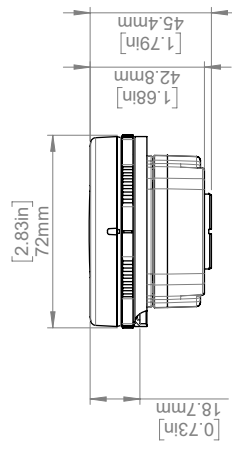
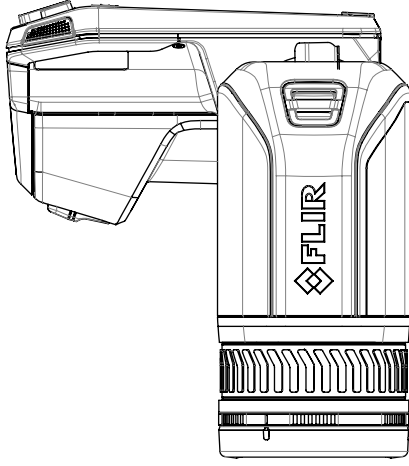
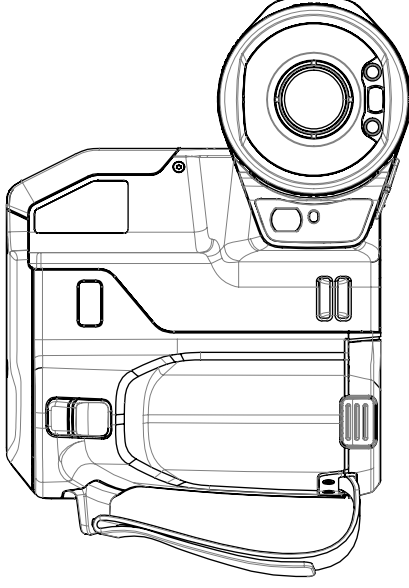
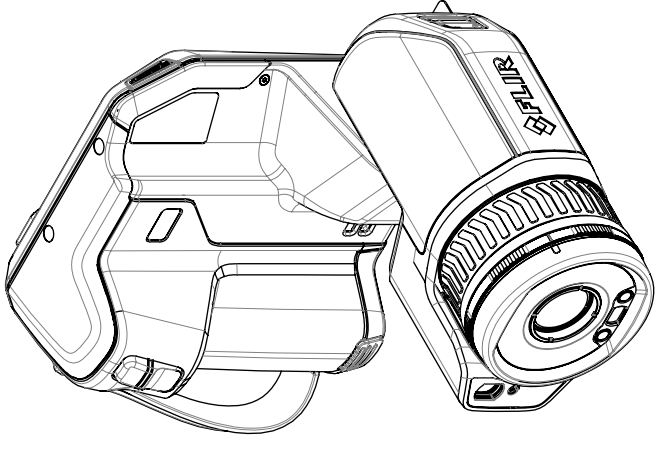

For additional dimensions see page 1

Modified 2020-01-14 Denomination	Check JOHE	Drawn by R&D Instruments	FLIR
Basic dimensions FLIR T5xx			Sheet Z(4)
Size A3			Rev B
Scale 1:5			Drawing No. T129991

Camera with Lens IR f=70mm (6°)

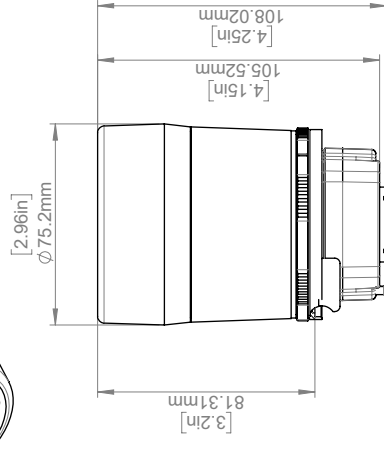
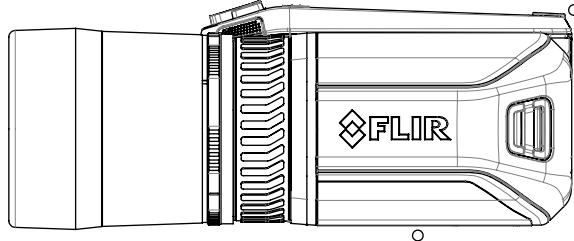
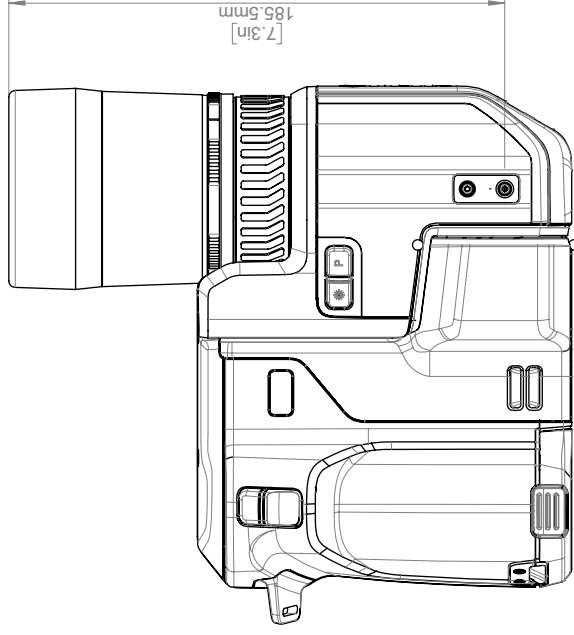
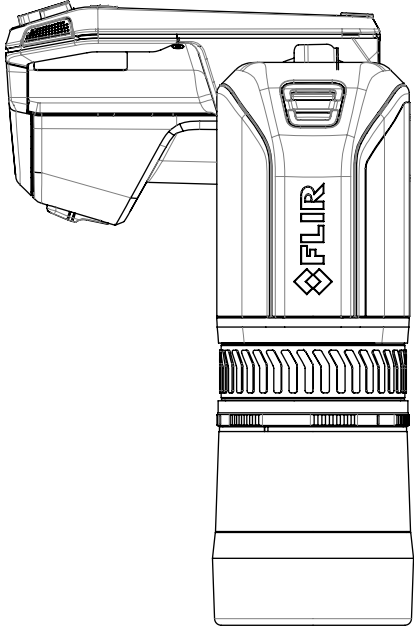
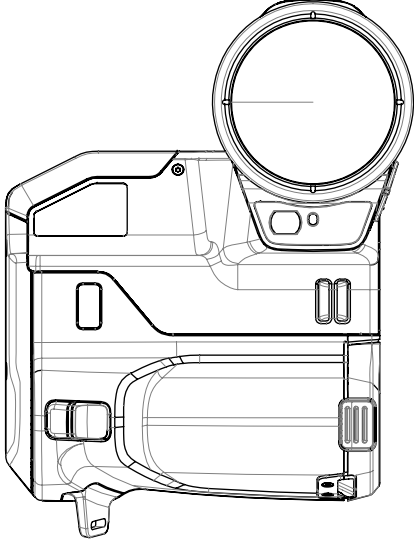
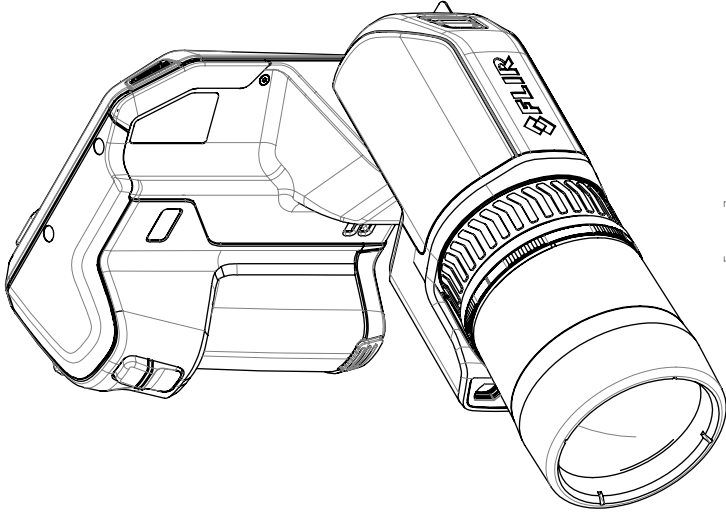

For additional dimensions see page 1

Modified 2020-01-14 Denomination	Check JOHE	Drawn by R&D Instruments	Size A3	Sheet 3(4)	Rev B
Basic dimensions FLIR T5xx			Scale 1:5	Drawing No. T129991	



Täby, Sweden July 07, 2021

AQ320246

CE Declaration of Conformity – EU Declaration of Conformity

Product:

Name and address of the manufacturer: FLIR Systems AB
 PO Box 7376
 SE-187 15 Täby, Sweden

This declaration of conformity is issued under the sole responsibility of the manufacturer.

The object of the declaration: FLIR T5XX-, T8XX- and GF7X-series (Product Model Name FLIR-T8210).

The object of the declaration described above is in conformity with the relevant Union harmonisation legislation:

Directives

Directive	2012/19/EU	Waste electrical and electric equipment
Directive	2011/65/EU	RoHS and 2015/830/EU (Phtalates)
Directive	2014/53/EU	Radio Equipment Directive (RED)

Standards

Emission:	EN 61000-6-3/A1:2011	EMC – Generic standards
Immunity:	EN 61000-6-2:2005	Electromagnetic Compability Generic
	EN 301489-1:2016 v2.1.0	ERM – EMC for radio equipment
	EN 301489-17:2012 v2.2.1	ERM – EMC Wideband data
EMC Radio	ETSI EN 301 489-17 v3.2.0	EMC for radio, broadband data transmission
RoHS:	EN 50581:2012	Technical documentation
Radio:	ETSI EN 300 328 v2.2.2	Harmonized EN covering essential requirements of the R&TTE Directive
	ETSI EN 301 893 v.2.1.1	5GHz WLAN
Safety:	IEC 62368-1:2014 Ed 2 and Cor. 1:2015, EN 62368-1:2014/AC:2015/A11:2017	Audio/video, information and communication technology equipment, Part 1: Safety

FLIR Systems AB
 Quality Assurance



Lea Dabiri
 Quality Manager