

# INSTALLATION INSTRUCTIONS

## SMALL FLAT PANEL DISPLAY MOUNTING BRACKET



FSB-4394

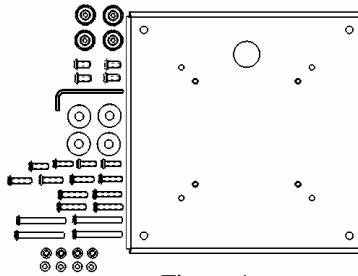

Figure 1

- |                                       |                                       |
|---------------------------------------|---------------------------------------|
| (1) FSB Interface Bracket             | (4) Mounting Buttons                  |
| (4) 10-24 x .5 Button Head Cap Screw  | (4) .875 x .33 x .375 Nylon Washer    |
| (4) M4 x 20mm Phillips Head Cap Screw | (4) M4 x 25mm Phillips Head Cap Screw |
| (4) M4 x 40mm Phillips Head Cap Screw | (1) 1/8 Allen Key                     |
| (4) M4 x 16mm Phillips Head Cap Screw | (4) M4 Shoulder washers               |
| (4) M4 Flat washers                   |                                       |

**BEFORE PROCEEDING:** Unpack the carton, verify contents shown in Figure 1 and read installation instructions completely. If you are missing any of the listed components, please contact Customer Service at 1-800/582-6480.

## CAUTION! Displays are Extremely Fragile.

**NOTE:** If installing screen onto a VESA 100mm X 100mm mount, skip to step 2 on Page 2 (mounting button installation is not required).

1. Using #10-24 screws secure mounting button to bracket, with chamfered hole of mounting button (larger surface) facing bracket (4 places) (see Figure 2 and Figure 3).

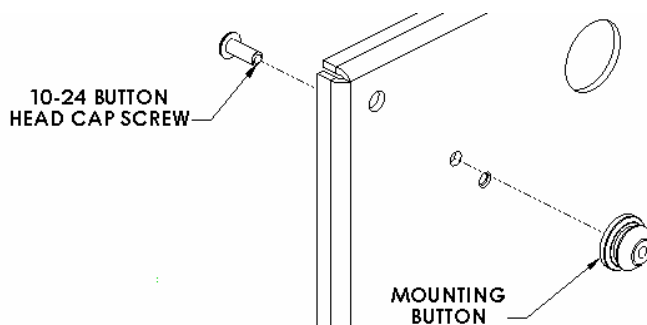

Figure 2

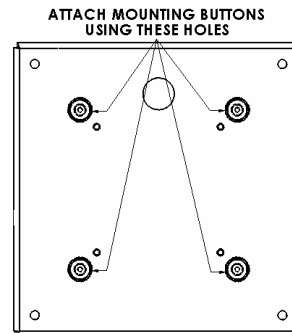

Figure 3

# WARNING

**ALL COMPONENTS MUST BE SECURELY FASTENED TO A STRUCTURAL MEMBER CAPABLE OF SUPPORTING 4 TIMES THE COMBINED WEIGHT OF ALL COMPONENTS PLUS THE EQUIPMENT BEING MOUNTED. IF IT CANNOT SUPPORT THIS WEIGHT, THE STRUCTURE MUST BE REINFORCED. THE MAXIMUM WEIGHT TO BE INSTALLED ON THE BRACKET IS 45 POUNDS (20.41 KG).**

2. Place nylon spacers on mounting holes, aligning hole pattern on brackets with pattern on back of display (see Figure 3 and Figure 4).

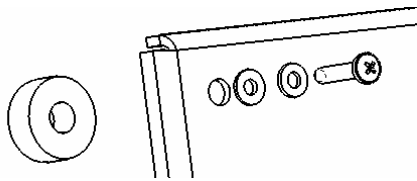

Figure 3

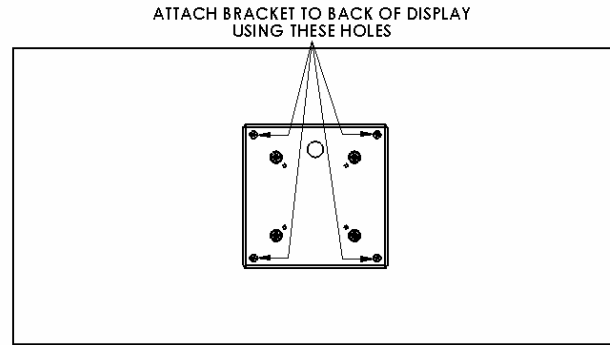

Figure 4

3. Using the proper length of M4 screws (depending on screen), secure bracket to display. Do not over tighten screws.
4. **For Chief Q2™ mounts with 5" X 5" Mounting System** - With the aid of another person, lift the display up to the mount, align the mounting buttons on the plasma with the slots in the mount, and set the screen into place. Lower safety latch on the Chief Mount to secure your display, making sure latch is completely engaged.
5. **For VESA 100mm X 100mm Mounting Systems** - With the aid of another person, lift display up to the mount, align threaded holes of interface bracket to mounting holes of mount. Attach screen to mount (per mount instructions) with M4 screws provided with mount.
6. **For Chief Q2™ mounts with 100mm X 100mm Mounting System** – Using the buttons from the mount, secure the buttons with the 16mm M4 screws that come with bracket. Follow the diagrams below for button mounting. With the aid of another person, lift the display up to the mount, align the mounting buttons on the plasma with the slots in the mount, and set the screen into place. Lower safety latch on the Chief Mount to secure your display, making sure latch is completely engaged.

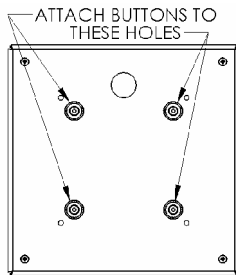

Figure 5

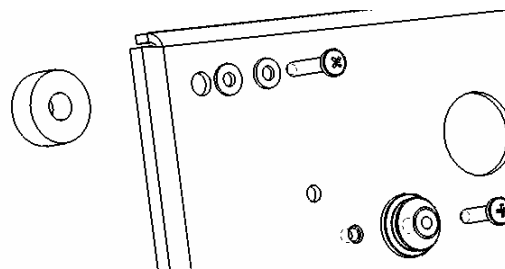

Figure 6