

FLH20

HIGH-LOAD CAPACITY FLOOR BOX

FSR

Metal Products Group

FLH20

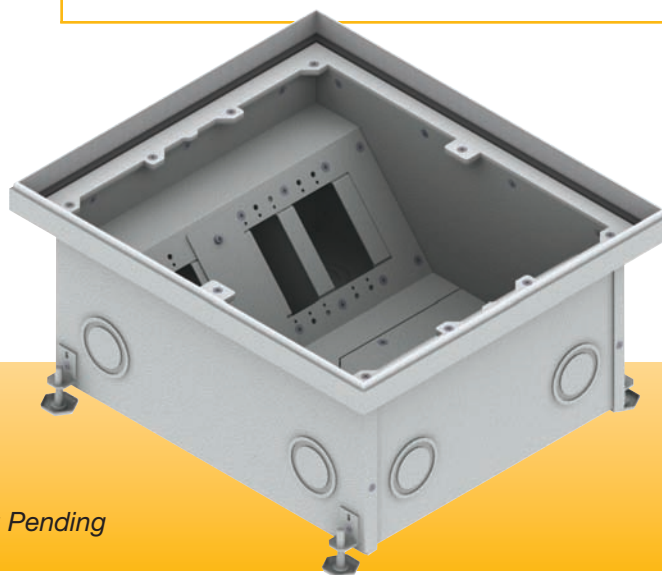
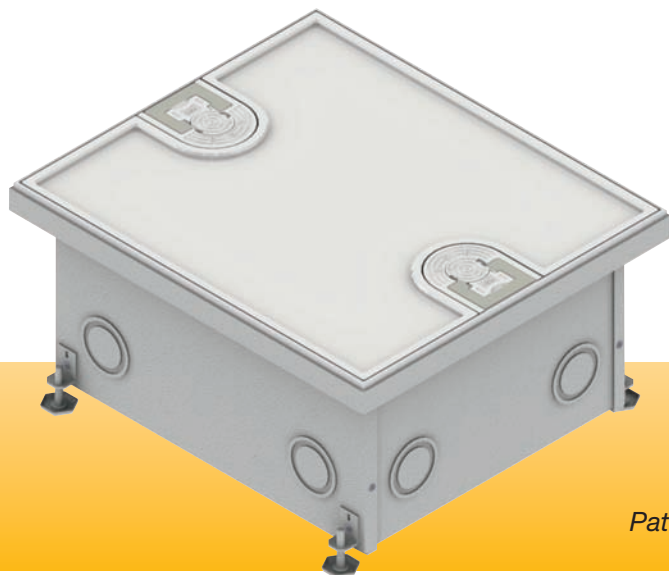

Patent Pending

DESCRIPTION

The FLH20 high load capacity floor boxes combine rugged construction and elegant design. They are ideal for high traffic areas where heavy equipment such as forklifts, automobiles, scissor lifts and portable stages are used.

All covers are designed to meet H20 load ratings using 7/8" thick type 6061 T6 heat-treated aluminum. The clear anodized cover is available for use in concrete, carpet or tiled floors. The two cable exit doors incorporate FSR's exclusive 3 position cam locks which allow "One Click" operation to open the cable door or remove the cover. An alternate cover option is a plain cover with no cable access doors for a when the box is used as a junction box and cable exit capability is unnecessary.

The innovations continue to the back box. The FLH20's internal brackets are adjustable to provide a variety of installation possibilities based around standard electrical gang plates. Numerous combinations for both high and low voltage configurations make it the most flexible floor box available. Two universal openings accept one or two electrical plates with a maximum total size of 4 gangs. Each compartment can be electrically isolated or wiring can be passed between compartments with the use of our screwless separator system.

FLH-20 Floor Boxes meet the UL scrub-water testing standards.

Note: When this box is used on grade, it should be encased in concrete to prevent contact with the grade. To ensure compliance, we recommend using the FSR Pour Pan Accessory.

FEATURES

- Designed for heavy floor traffic
- Field configured multiple gang arrangements
- Integral carpet edging or solid design
- Leveling feet for easy installation
- Cable pass-through ready
- Two locking cable exit doors (not on utility cover)
- Custom milled pocket depth available-consult factory

SPECIFICATIONS

Size:	See dimension drawings
Edging:	Height: 0.20" Colors: Silver
Weight:	Box: 36.5 lbs. (approximate)
Knockouts:	Total of 12 either 1", 1.25" or 1.5" diameter
Accessory Plates	Two block-off plates Four gang plate divider
Included:	Four center dividers

TYPICAL APPLICATIONS

Hotels, Ballrooms, Stages, Convention Centers, Museums, Warehouses, Showrooms, Lobbies

FSR Inc.

244 Bergen Boulevard, Woodland Park, NJ 07424
 Phone: 973.785.4347 · Fax: 973.785.4207
 Web: www.fsrinc.com · E-mail: sales@fsrinc.com
 Order Desk: 1-800-332-FSR1

LIT1217C

INTERNAL BRACKET DETAIL

Parts are included to assemble any two of the four gang arrangements shown below. Simply choose a triangle number and install the divider(s) as shown below.

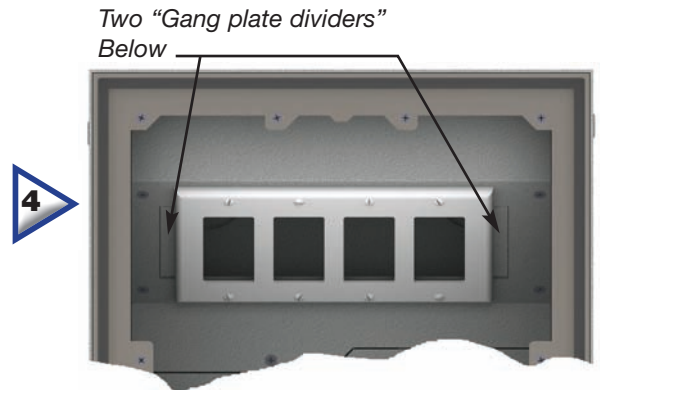
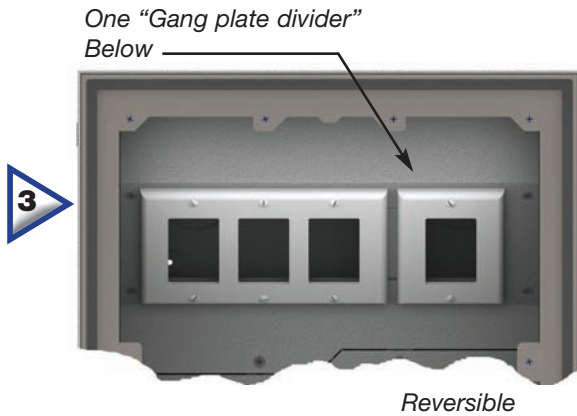
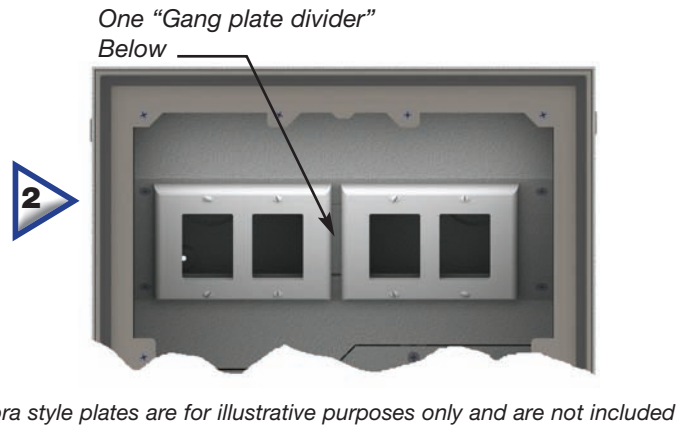
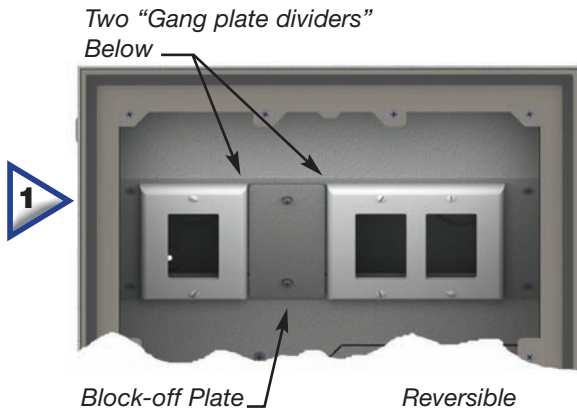

Compartment Dividers

Remove or arrange as needed to isolate compartments. Warning: Must be used on a compartment where line voltage wiring is present

Gang Plate Dividers

The numbers shown in yellow boxes on these dividers correspond to gang arrangement numbers shown in triangles alongside the four black box images above.

Center Dividers
Remove to run cables across compartments

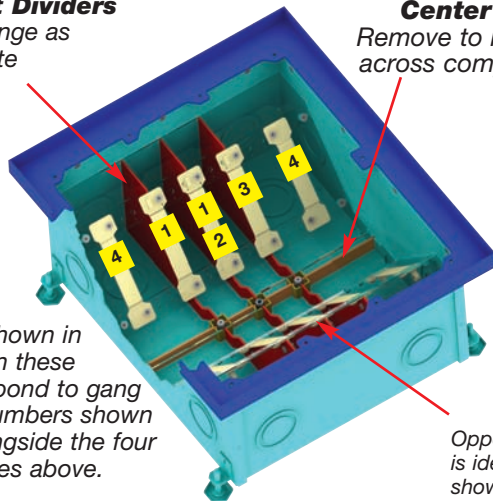

Opposite box side is identical to the shown side.

FLH-20 Ordering Information

For Carpet Covered Floor Applications:

16806	FLH20-1S-C ALM CARPET COVER
16807	FLH20-1-BX BACK BOX, CARPET
16847	FLH20-1-JBC JUNCTION BOX COVER

For Bare Concrete Floor Applications:

16844	FLH20-0S-C ALM SOLID LID CVR
16845	FLH20-0-BX BACK BOX-SOLID CVR
16846	FLH20-0-JBC JUNCTION BOX COVER

FLH-20 Floor Boxes meet the UL scrub-water testing standards

Touchboards

205 Westwood Ave, Long Branch, NJ 07740
Phone: 866-94 BOARDS (26273) / (732)-222-1511
Fax: (732)-222-7088 | E-mail: sales@touchboards.com

FLH20-0 BOX & COVER DIMENSIONS FOR CONCRETE FLOOR USE

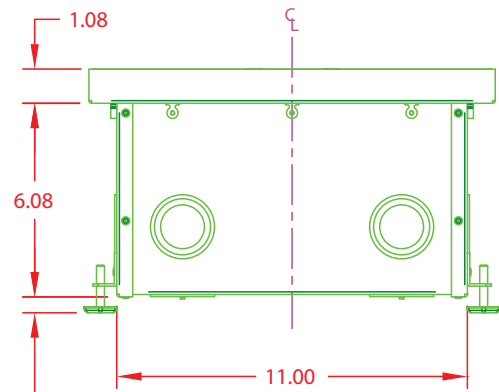
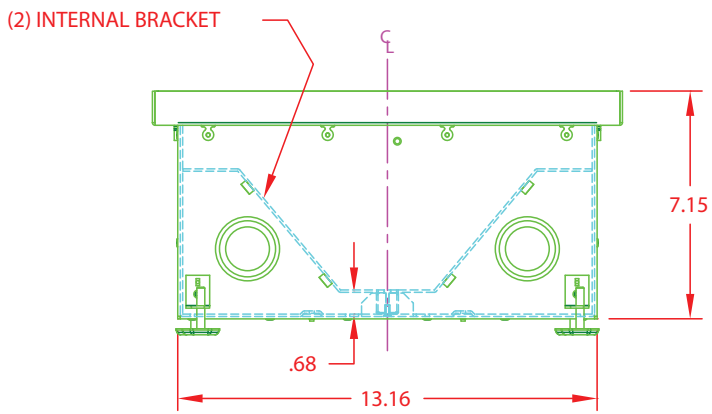
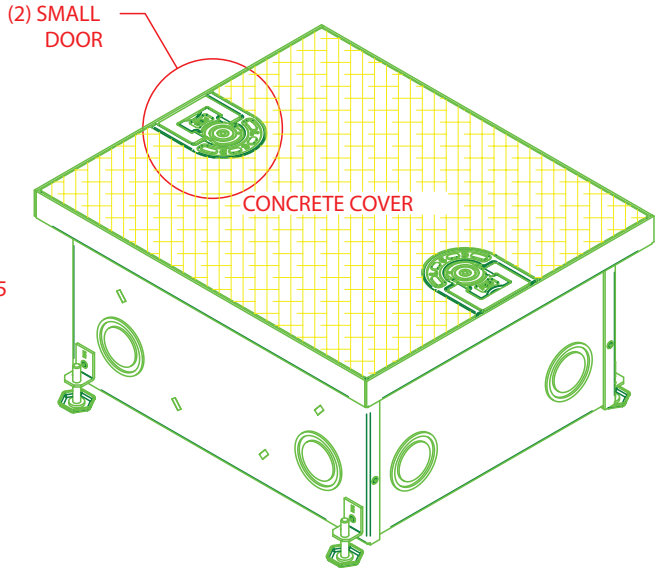
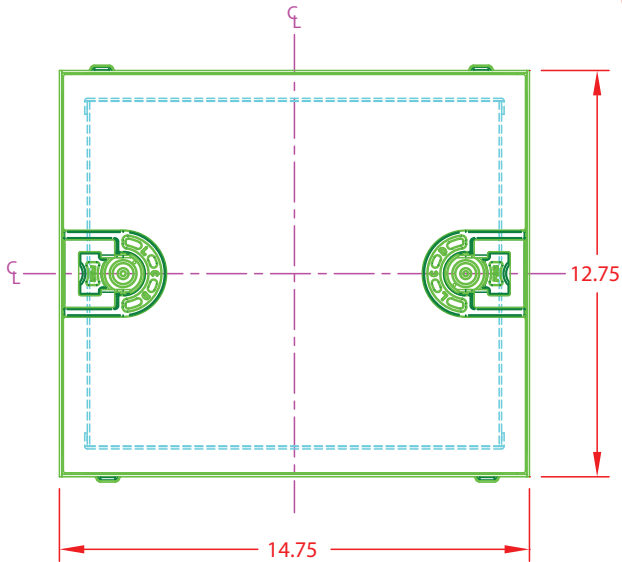
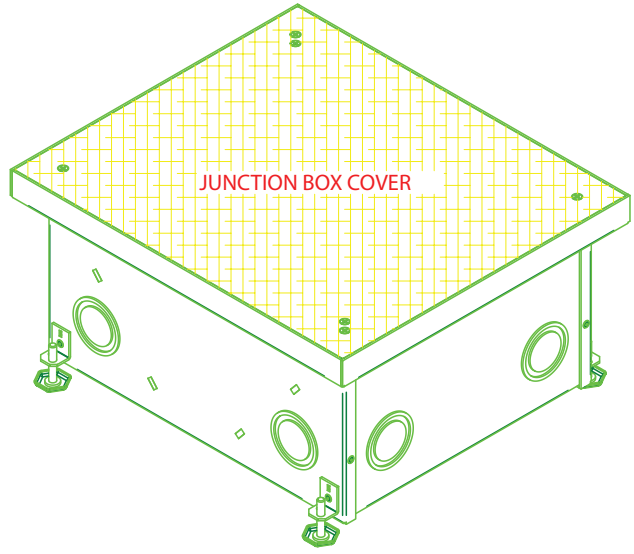
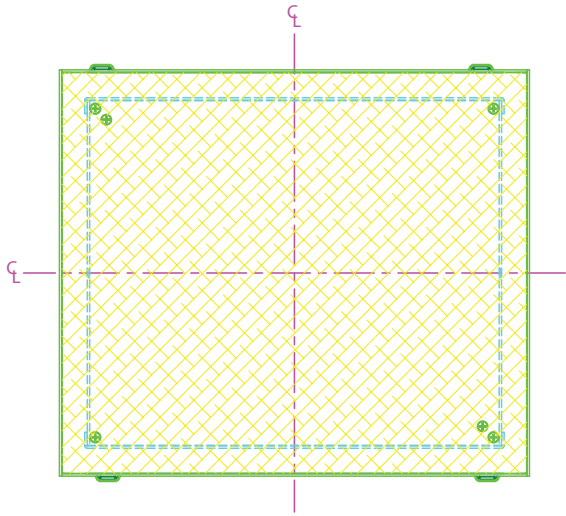

.18 MIN. - .88 MAX.
(.70 ADJUSTMENT RANGE)

FLH20-1 BOX & COVER DIMENSIONS FOR CARPETED FLOOR USE

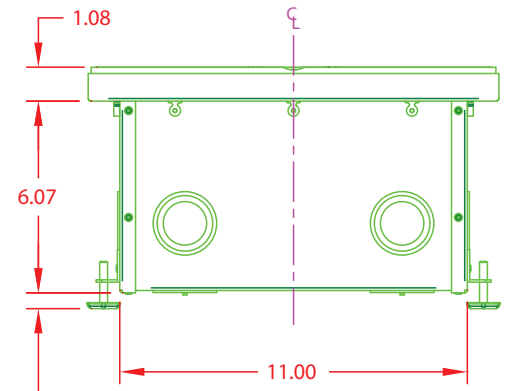
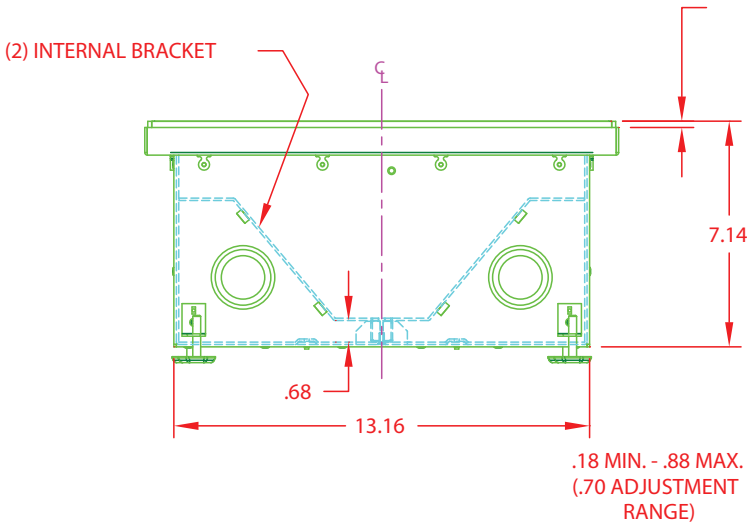
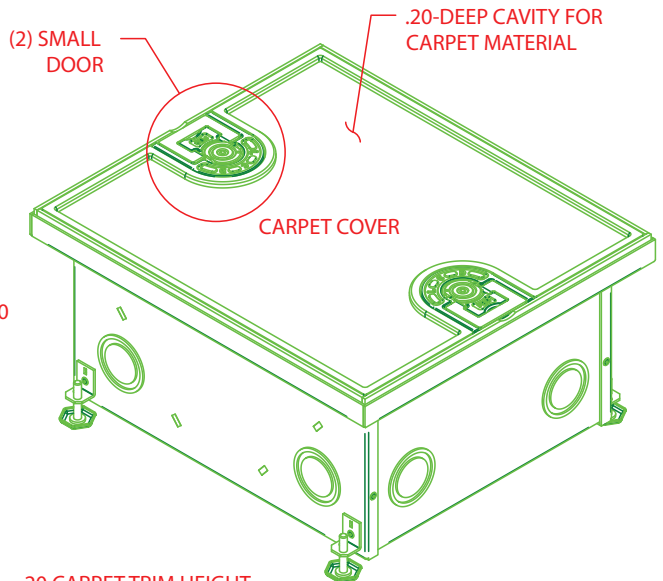
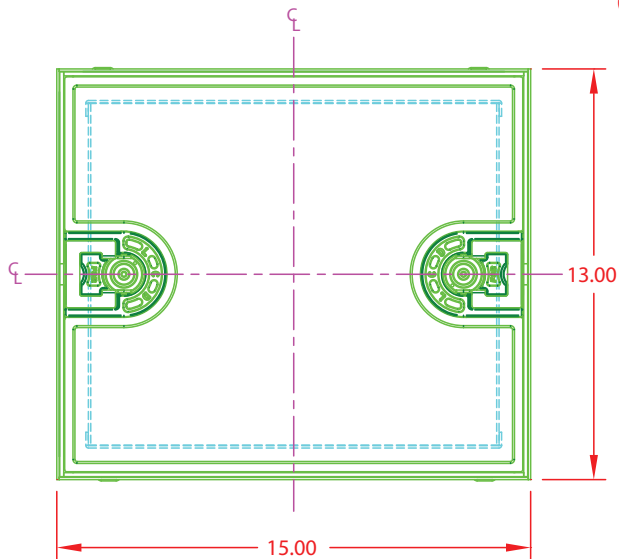
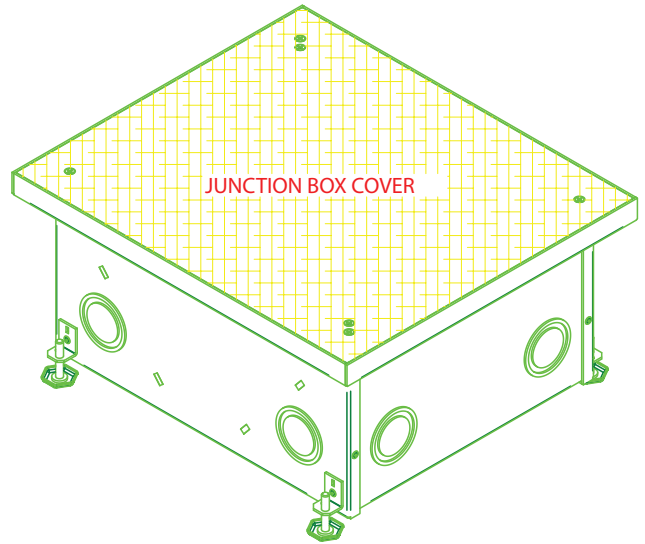
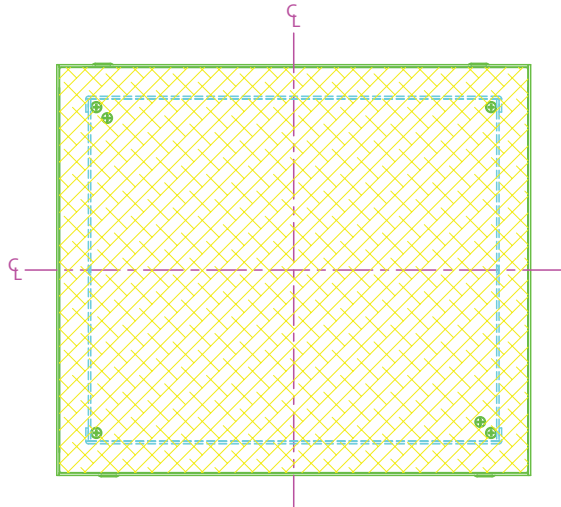

Specifications are subject to change without notice.



244 Bergen Boulevard, Woodland Park, NJ 07424
 Phone: 973.785.4347 · Fax: 973.785.4207
 Web: www.fsrinc.com · E-mail: sales@fsrinc.com

