

FSR

Video Products Group

MAS-6100 MAS-6100A AV SWITCHER SCALERS

Touchboards

205 Westwood Ave, Long Branch, NJ 07740
Phone: 866-94 BOARDS (26273) / (732)-222-1511
Fax: (732)-222-7088 | E-mail: sales@touchboards.com

INSTALLATION AND OPERATING GUIDE



BASED ON FIRMWARE REV. 1.85

COMPLIANCE AND SAFETY

PROPRIETARY INFORMATION

All information in this manual is proprietary to and the property of FSR Inc. This publication is protected by the Federal Copyright Law, with all rights reserved. No part of this document may be reproduced, transcribed, or transmitted, in any form or by any means, without prior explicit written permission from FSR Inc.

OPERATOR'S SAFETY SUMMARY

The general safety information in this summary is for operating personnel.

Read Instructions. Read and understand all safety and operating instructions before using this equipment. Keep the instructions handy.

Removal of the top cover may expose dangerous voltages. To avoid personal injury, disconnect all power sources before removing the top cover. Do not operate the unit with the cover removed.

Power Source:

This product is intended to operate from the power source detailed in the specification section of this manual. Do not use any other power source or exceed voltage limits.

Grounding the Product:

This product is grounded through the grounding conductor of the power cord. To avoid electrical shock, plug the power cord into a properly wired receptacle before connecting to the product input or output terminals.

Use the Proper Power Cord Use only the power cord and connector specified for your product. Use only a power cord that is in good condition. Refer cord and connector changes to qualified service personnel.

TABLE OF CONTENTS

COMPLIANCE AND SAFETY	2
PROPRIETARY INFORMATION.....	2
OPERATOR'S SAFETY SUMMARY.....	2
INTRODUCTION	5
INSTALLATION	6
TYPICAL APPLICATION	6
MECHANICAL DIMENSIONS	7
FRONT AND REAR PANEL OPERATION	8
FRONT PANEL CONTROLS.....	8
SPECIAL BUTTON COMBINATIONS AND THEIR FUNCTIONS	9
REAR PANEL CONTROLS	9
ACCESSING AND USING THE ON SCREEN MENUS	10
MENU NAVIGATION BUTTONS.....	10
MAS-6100 MENU TREE	11
THE ROOT MENU STRUCTURE	12
OUTPUT ADJUST GROUP	12
SCALER ADJUST GROUP.....	14
KEY ADJUST GROUP.....	17
COMMON KEYS OPERATIONS	20
INPUT ADJUST GROUP	21
RGB INPUT SUB MENU ITEMS.....	21
CV & YC INPUT SUB MENU ITEMS.....	24
TRANSITION ADJUST GROUP.....	25
CUT and FADE SUB MENU ITEMS.....	26
WIPE SUB MENU ITEMS.....	26
ADJUST RESOLUTIONS GROUP.....	27
SYSTEM SETTINGS GROUP.....	30
IR REMOTE CONTROL COMMANDS	32
PINOOTS AND CABLING	33
HD15 CONNECTOR.....	33
4 PIN MINI-DIN S-VIDEO CONNECTOR (YC) INPUT.....	33
AUDIO WIRING	34
DB9 CONNECTOR	35
MAS-6100 RS232 CONTROL SPECIFICATION	37
COMMUNICATION PROTOCOL BASICS.....	37

PACKET FORMAT38
FRONT PANEL BUTTON EXAMPLES39
FUNCTION LIST.....45
SPECIFICATIONS.....51
WARRANTY AND RETURN INFO.....52
WARRANTY POLICY52
SERVICE AND RETURN AUTHORIZATION52
CONTACT INFORMATION52

INTRODUCTION

The MAS-6100 is a multi-purpose Video Switcher/Scaler that is ideal for boardroom and house of worship presentation systems. The MAS-6100 provides high quality scaling from Standard Definition, High Definition and Computer video sources to resolutions that match your projector, plasma or HD display.

The MAS-6100A adds a 4x1 stereo audio switcher with balanced output and adjustable delay to keep the audio and video in sync.

The MAS-6100's have 2 Composite Video Inputs, 2 S-Video Inputs, one Component input and one RGB Input. Both NTSC and PAL are supported.

The scaled output is selectable at any computer resolution up to 2048x2048 as well as all HDTV resolutions up to 1080p.

The MAS-6100 can be controlled in a variety of ways. The front panel along with an on-screen display handle all set-up and switching features. The 6200 can also be remotely controlled from the FSR Room Navigator or other control system via the RS-232 port or the IR Port.

To make IR control easy and painless, all IR codes are provided in a CCF format and are available on the FSR web site. These can be used in nearly any universal remote control or from any control system with IR output.

In addition to the standard scaling and switching capabilities, the MAS-6100 has a built in keyer to allow computer generated text to be superimposed upon a video background, pan and zoom and a host of other features normally found on much more expensive products.

FEATURES:

- Automatic Incoming Resolution Detection
- Video Outputs: One 3 RCA Component and 1HD-15 RGB/Component
- Video Inputs: Two BNC Composite, two S-Video, One HD-15 Computer / Component and one 5BNC Computer / Component
- Computer Resolutions to 2048x2048
- HDTV Resolutions to 1080p
- Multiple Worldwide Television Standards
- RS-232 and IR Control
- Image Pan and Zoom
- All Input Types are Scaled
- Chromakey and Lumakey
- Image Rotation and Automatic picture sizing
- 4x1 Stereo Audio Switcher with Balanced Output and adjustable delay (MAS-6100A)
- Wipe and Fade transitions

INSTALLATION

The MAS-6100 mounts easily into a standard 19" rack. It should be placed in an area where the user can easily access the front panel controls. The units are designed to be rack mounted and are supplied with front rack-mount hardware.

When rack mounting the unit, remember that the maximum ambient operating temperature for the unit is 40 degrees C. Leave at least one inch of space front and rear to make sure that the airflow is not restricted.

When installing equipment into a rack, distribute the units evenly to prevent hazardous conditions that may be created by uneven weight distribution. Connect the unit only to a properly rated supply circuit. Reliable grounding (earthing) of rack-mounted equipment should be maintained.

TYPICAL APPLICATION

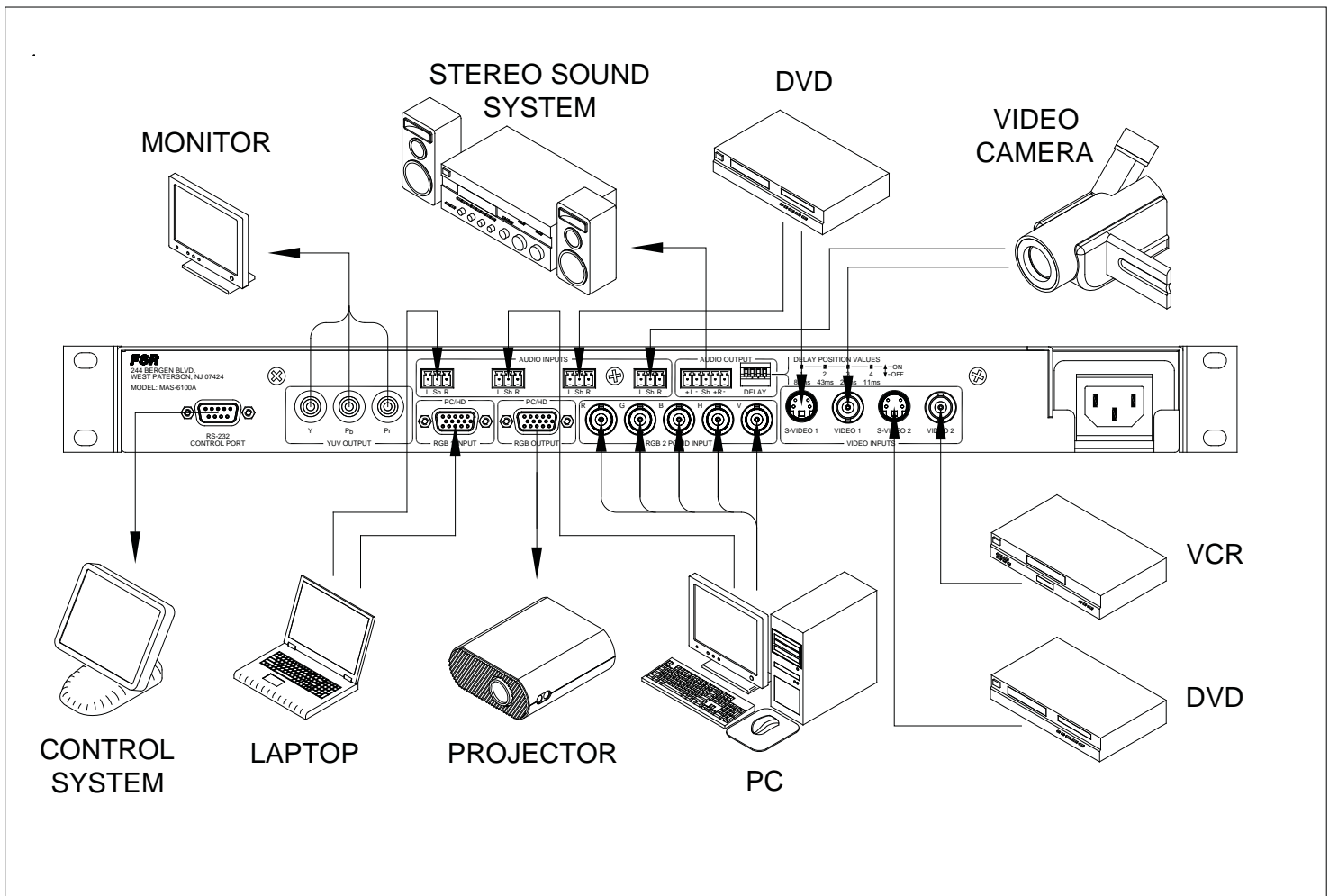

MECHANICAL DIMENSIONS

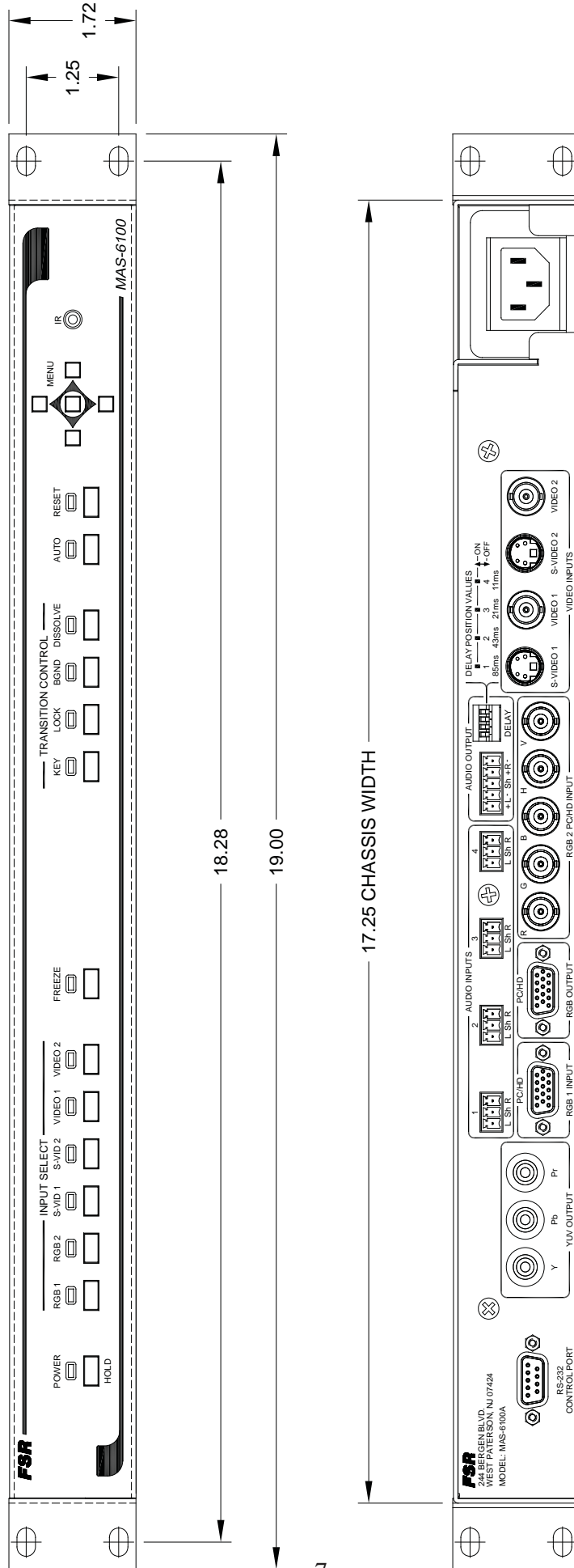

DEPTH INSIDE RACK IS APPROXIMATELY 11.00"

FRONT AND REAR PANEL OPERATION

FRONT PANEL CONTROLS

POWER ON OFF

Pressing the power button will power up the MAS-6100. The unit will run a brief diagnostic sequence and be operational in a few seconds. Pressing and holding the power button for two seconds and releasing will power down the unit.

INPUT SELECT

Press and release any of the six input select buttons to select and display the desired video source. An audio switch will follow if there is an audio input associated with the new video input selected. (MAS-6100A only). See “Audio Input Number” setting under Input Setup for details on audio input setup selection and muting.

TRANSITION CONTROL:

FREEZE

Press and release to freeze the current display. This does not affect the background image. A second press will unfreeze the display. This setting is also available through the on screen menu.

KEY

Press and release to enable Keying. The key color default is black and will be transparent allowing the background image to show through. This setting can be changed to any chroma or luma settings through the on screen menu.

LOCK

Press to activate GENLOCK. This locks the unit’s output to the current lock source. See “adjust outputs menu” for details. This setting is also available through the on screen menu.

BGND

Press and release to put the unit into “Lock and Mix” mode. This will allow the use of the Key and Dissolve effects. This setting is also available through the on screen menu.

NOTE: When using YUV as a background, the YUV input must be progressive.

DISSOLVE

Fades the current image in and out. When BKND is active the unit will fade between the current and previously selected input. If keying is active, the unit will fade in and out of key mode.

AUTO

Press and release to automatically adjust a variety of settings for the current analog RGB input. This setting is also available through the on screen menu. This adjustments will usually yield a good “best guess” automatic setup.

RESET

Press and hold until one beep is heard. This returns the unit to the last saved “power up” default settings. Holding this button in for longer will return two beeps (low/high sound) will perform a factory reset of user settings. This will return the unit to the original factory default settings.

SPECIAL BUTTON COMBINATIONS AND THEIR FUNCTIONS

FRONT PANEL LOCKOUT

Press the power and reset buttons together until the Power LED flashes to disable the front panel buttons. A second push will restore front panel operation (steady Power LED).

REAR PANEL CONTROLS

AUDIO DELAY

A dip switch array is located on the rear panel and provides audio delay options which can be used to compensate for internal video processing delays and effectively synchronize the audio and video. The switches can be used in any combination to create the desired audio delay. The silk-screening lists the various time delay settings in milliseconds.

The dip switch values are 85ms, 43ms, 21ms, and 11ms. When a switch is moved to the “UP” position the delay is added to the audio.

ACCESSING AND USING THE ON SCREEN MENUS

MENU NAVIGATION BUTTONS

The ON SCREEN MENU is accessed via the five push-button array on the right of the front panel. Push the menu select button in the center to view the on screen display. The on screen display will remain visible for 10 seconds after the last button push before disappearing.

The ARROW UP, DOWN, LEFT and RIGHT are used to navigate through the on screen menus and change setting values. Specifically, the ARROW RIGHT button is used to move forward through the various menu headings or increment a value. The ARROW LEFT button is used to move backward or decrement a value.

Here are the nine root menu main group headings in the order they appear:

- MODEL DISPLAY (FSR MAS-6100)
- VIEW THE VERSION NUMBER
- ADJUSTING THE VIDEO OUTPUT
- SCALER ADJUST
- KEY ADJUST
- INPUT ADJUST
- TRANSITION ADJUST
- RESOLUTIONS ADJUST (only visible when “Advanced Menus” is turned on under “System Settings”).
- SYSTEM SETTINGS

When a root menu heading is visible, press the menu select button to view and further select additional sub menus under the main heading. Under each sub menu heading, changeable values will appear in brackets [] Pressing the menu select button will cause the brackets to flash. The setting value can be adjusted by pressing the LEFT and RIGHT ARROW KEYS Press the menu button again to store the setting value. The brackets will stop flashing and remain steady at this point. After the desired setting is made, push the right or left arrow key to navigate through and adjust additional sub menu settings. When finished, use the right arrow key to navigate to the EXIT menu heading. Push the MENU SELECT button to back out to the root menus shown above.

MAS-6100 MENU TREE

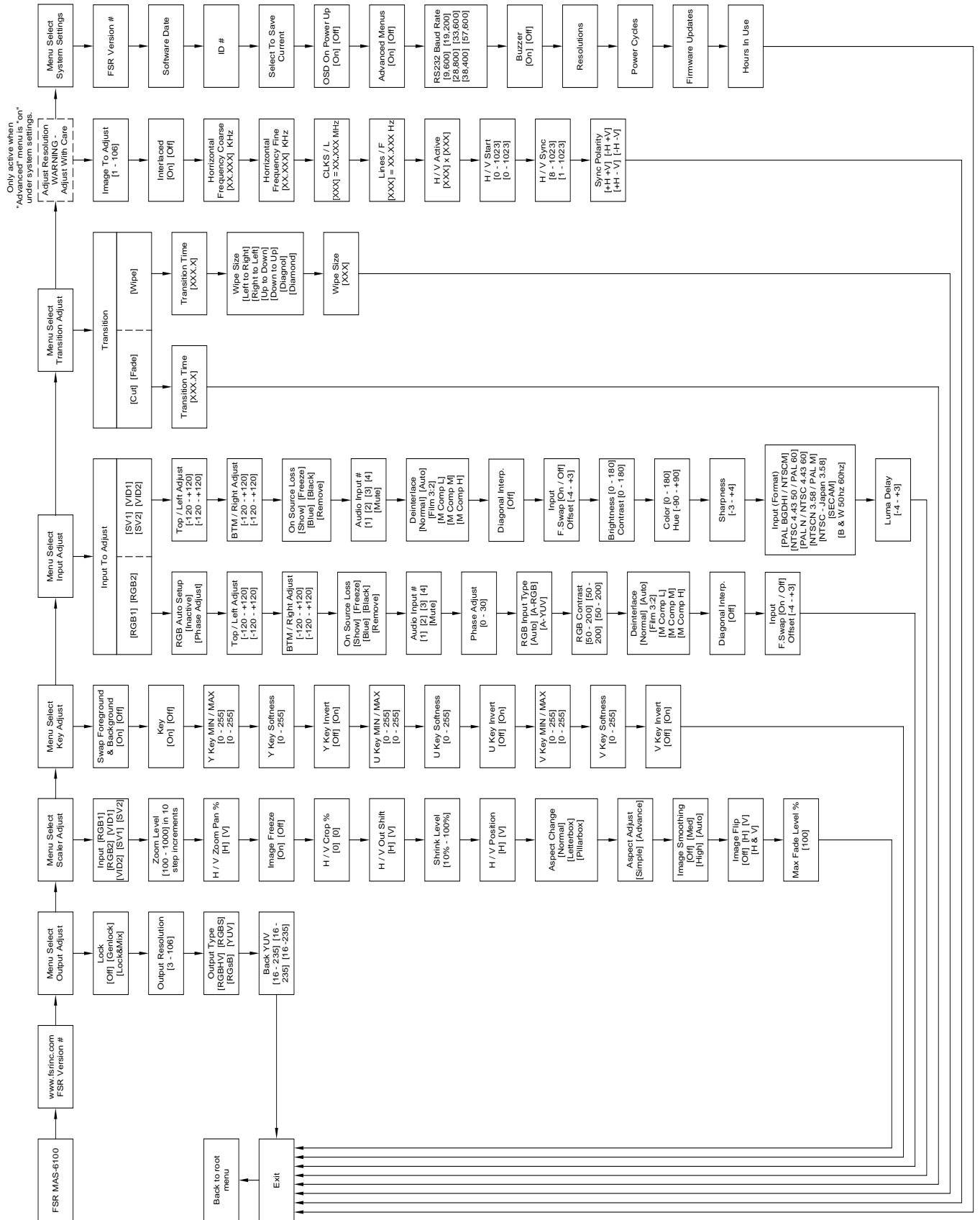

THE ROOT MENU STRUCTURE

Menus are arranged so that a particular general function has a menu name on the top line and beneath that either a sub-menu or one or more related individual settings are displayed.

In some cases the functionality is global – meaning it has an effect on the unit as a whole (such as changing the output resolution). In the majority of cases, the function is related to a specific operational area of the unit, detailed by the text in the top line.

There are two screens that appear before the Group Menus (sub-menus) are accessed. These screens are for informational purposes and are not adjustable

The first is the ‘welcome’ display shown above indicating the model of the unit.

The next menu item displays the firmware information screen (the numbers on your unit will be different to those shown).

At the end of all Group Menus will be an ‘Exit’ item. Simply select this to exit the existing menu structure and return to the previous one in the hierarchy.

OUTPUT ADJUST GROUP

This menu group allows adjustments to be made that specifically affect the output of the unit, including output resolution and locking/overlaying onto a computer or video source.

800 x 600 60Hz Lock [Off] (RGB1)
--

This menu item allows the lock mode to be selected and the lock source to be defined. The top line of the display shows the current detected resolution of the selected lock source (RGB1 in this example). The lock mode can be either Off, Genlock or Lock & Mix, with the operation of these shown in the following table:

Lock mode	Description
Off	The output resolution of the Output is defined by the setting for Output Resolution and there will be no background source visible
Genlock	The output video will be “Genlocked” to the selected lock source. The output signal will be synchronous to the input sync and adjustable but there will still be no lock source visible.
Lock & Mix	The output video will be locked to the selected source, the syncs will be locked (but with an additional internal video processing delay) and the background for the output will be that of the Lock source (unless foreground and background are swapped).

In both Genlock and Lock & Mix modes the source selected for the lock input determines the resolution of the Output image. The output resolution for the entire image can be no different than the resolution of the lock source. All synchronization signals are re-generated within the unit so they may look slightly different when compared on an oscilloscope to the original source.

NOTE: Before turning the Lock feature on, you first must select a valid Lock source. Not all Lock sources are available, depending on the main Input source in use (see “Scaler Adjust Group” NOTE). For instance, you cannot overlay one CV or YC source over a different CV or YC source, or one RGB1 and RGB2 source over another RGB1 and RGB2 source – you are restricted to overlaying CV/YC over RGB1 and RGB2, or RGB1 and RGB2 over CV/YC (the exception is where you can overlay one source over itself).

1024 x 768 60Hz Output res.	[28]
--	-------------

Your unit can handle a very wide array of inputs and convert them all to a single output signal with defined characteristics. This output resolution will remain in place until changed or it may be overridden by the lock mode and source.

The top line of the display will show the current output resolution selected.

Output Adjust Output type	[RGBHV]
--	----------------

This menu item allows you to select the type of signal output your unit will provide. Types of output vary depending on the resolution selected and include various types of component signals Y/R-Y/B-Y or YPbPr, the full range of RGB type signals RGBHV, RGBS and RGSB (Sync on green).

Output Adjust Back Y/U/V	[16] [128] [128]
---	--------------------------

Sets the value of the fixed background color, which is present when Dissolve is used with no Lock source background displayed.

SCALER ADJUST GROUP

This menu group allows adjustment to be made to window specific parameters such as the window source, position, size and zoom level.

NTSC / 60Hz
Input [YC1]

The Input display screen allows the input source for the currently selected window to be changed. The top line of the display shows the detected characteristics of the signal. Valid Input sources match those available on the front of the unit

NOTE: If you have Lock mode active (set to either Genlock or Lock & Mix) then you will be restricted in your choice of sources. This is because you cannot overlay one CV or YC source over a different CV or YC source, or one RGB1 and RGB2 source over another RGB1 and RGB2 source – you are restricted to overlaying CV/YC over RGB1 and RGB2, or RGB1 and RGB2 over CV/YC (the exception is where you can overlay one source over itself). Turn Lock mode off in order to select a wider range of sources.

Scaler Adjust
Zoom level % [100]

Changing this option, sets the amount of picture magnification you wish to use for the window Source. You are provided with the options to zoom the image from 100% to 1000% (10x zoom).

Scaler adjust
H/V zoom % [100] [100]1,333

When parameter 'Aspect Adjust' later in this sub-menu is set to 'Advanced', this display is made accessible. It allows the independent setting of the horizontal and vertical zoom values. The third number (1.333 in the example) is the Aspect Ratio resulting from the adjustments, which is automatically calculated for you based on the incoming resolution and the H & V Zoom values.

Most resolutions are 4:3 ratio, thus the third number will be 1.333 (4 divided by 3). Another common aspect ratio is 16:9 (16 divided by 9 = 1.777). PAL and NTSC inputs are physically 4:3 on your video monitor, but their actual pixel/line ratios are different and so will not display as 1.333.

Scaler Adjust
H/V zoom pan * [50] [50]

Once an image has been 'zoomed', this control allows the image to be positioned within the window so that any portion can be seen, not just the middle.

Scaler Adjust
Image freeze [Off]

This menu item allows the image to be frozen or unfrozen – thus keeping a single image on screen indefinitely. Note that images are not stored when power is removed from the unit.

H/V Crop *
[0] [0]

This allows the scaled image to be cropped at the top/bottom edges, or at the sides. Typically, this is used when performing a picture-in-picture (PIP) function, where the incoming video signal has a letterbox or pillarbox size (i.e. it has black areas at the top/bottom or sides). By adjusting the H/V values, you can crop out the black areas to correct the size on the final output screen. Note that it does not change the shape or aspect ratio of the image. It just removes the parts of the image that are not required.

Scaler Adjust
H/V out shift [0] [0]

This positions the selected Window horizontally and vertically on the monitor. This should only be used for 'fine tuning' and should not normally require adjustment – use the Shrink H/V adjustment when your image is less than 100% Shrink value.

Scaler Adjust
Shrink level* [50] [On]

Shrink Level determines the percentage of the monitor's total available screen space that the selected Window image occupies. Adjustment is provided for a reduction down to 10% of the overall output size. In most cases, this feature is used for picture-in-picture (PIP) when a background image is being used (for units with overlay abilities).

Note that this feature is 'Off' by default, so that the full image size of 100% is used. It can be adjusted by using the "U.SCAN" (under-scan) command on RS-232 port or the infrared remote control input.

Scaler Adjust Shrink H/V % [100] [100] 1.333
--

When parameter 'Aspect Adjust' in the System Menu structure is set to 'Advanced', this display is made accessible. It allows the setting of different Horizontal and Vertical 'shrink' sizes. The third number (1.333 in the example) is the Aspect Ratio resulting from the adjustments, which is automatically calculated for you based on the output resolution (the actual pixels & lines, not your physical screen size) and the H & V Shrink values.

Most resolutions are 4:3 ratio, thus the third number will be 1.333 (4 divided by 3). Another common aspect ratio is 16:9 (16 divided by 9 = 1.777). Therefore, to convert your 4:3 output into a 16:9 output, reduce the vertical (V) Shrink value to 75% and this will simulate a 16:9 output. PAL and NTSC inputs are physically 4:3 on your video monitor, but their actual pixel/line ratios are different and so will not display as 1.333.

Scaler Adjust H/U position % [100] [50]
--

This menu option determines the position of the shrunken image on the monitor screen. This will move an image that is less than the full screen size left/right or up/down within the monitor's available screen space. It will not let you move the image off the screen, so certain values will appear to have no effect (unless you use a very low Shrink value like 10%).

Scaler Adjust Aspect change [Normal]
--

With this menu, the images' aspect ratio can be set to properly match the display. The choices are Normal, Letterbox and Pillarbox.

Scaler Adjust Aspect adjust(Simple)
--

This parameter is used in conjunction with the Zoom and Shrink functions. When set to "Advanced", it allows the horizontal (H) and vertical (V) components of the Zoom and Shrink functions to be adjusted independently, thus allowing custom aspect ratios to be created, or to convert from one aspect ratio to another. When left as "Simple", the H/V components of Zoom and Shrink are adjusted equally i.e. H is equal to V.

Scaler Adjust Image smoothing	[Auto]
--	---------------

Image smoothing reduces the jagged-edges sometimes seen within an output image by softening it. It typically improves the quality of a scaled image greatly. There are four possible settings for this adjustment: “Off”, “Med.”, “High”, and “Auto”. The “Auto” setting is generally thought to be most desirable and will vary the smoothing process according to the amount of zoom taking place.

Scaler Adjust Image flip	[Off]
-------------------------------------	--------------

Occasionally, it’s necessary to cause the output image to be flipped Vertically, Horizontally or both – most commonly when a video projector is ceiling mounted, or for special effects.

Max Fade Level % [100]

This Menu item fades the selected layer. Adjustment range is from solid to fully transparent.

KEY ADJUST GROUP

At the end of this group you will find a section titled ”COMMON KEYER OPERATIONS” – this gives a step-by-step guide to keying out a particular color.

Key Adjust Swap fore/backgrnd	[Off]
--	--------------

This menu item allows you to swap the foreground and background images when Lock mode is set to Lock & Mix. It will have no effect in any other mode (since no background is present).

Normally, your foreground is the input (window) source and your background is the lock source. This then allows you to superimpose any graphics or video input on top of the lock source by keying out a certain color or range of colors in the input source. Swapping them means that the input source moves to the background and the lock source is now in front of it. Thus you are now keying out the lock source colors to reveal the input source behind it.

You will see that the Swap between foreground and background has no effect on the output resolution as this is always set by the Lock source.

Note that this is different than simply swapping the input and lock sources as that would affect the final output

resolution – see examples below:

Input source	Lock source	Swap	Foreground (Keyed)	Background (Non-keyed)	Output Resolution
XGA	NTSC	Off	XGA	NTSC	NTSC
XGA	NTSC	On	NTSC	XGA	NTSC
NTSC	XGA	Off	NTSC	XGA	XGA
NTSC	XGA	On	XGA	NTSC	XGA

(XGA is 1024x768)

Key Adjust Key ON/OFF	[Off]
--	----------------

This menu item turns keying On or Off for the current foreground. A keyed image is in essence one image superimposed over another – such that portions of the top image are made transparent (keyed out), so that the background image can show through. The following settings allow you to vary the color(s) that are keyed out.

Key Adjust Y Key min/max	[0] [32]
---	---------------------

The Min/Max parameters are used to select what range of Y (luminance/grey-scale) values are made transparent within the selected window/lock source. In order to key out part of an image, start with the max value and increase it until the required lighter parts within the window/lock source disappear. Then adjust the min level to bring back any darker parts of the image.

Key Adjust Y Key softness	[0]
--	--------------

The Y Key softness option removes noise from the keyed image, generally at the edges. Adjust as required to make the edges of the key as sharp or as soft as desired. The noise is where the analog to digital process (A/D conversion) may not sample a 50% brightness as being exactly 50% i.e. sometimes 49% and sometimes 51%. Increasing the softness value will broaden the range of keyed colors so that the keying of images varies depending on how close a color is to the keyed-out range.

Key Adjust
Y Key invert

[Off]

The Y Key invert changes the keying characteristics with respect to what colors of the foreground image you wish to 'key out'. Setting it to Off will cause the color range that's defined to be removed - remove the desired colors. Setting it to On will cause the color range that's defined to be kept - key out all other colors.

NOTE: The descriptions above behave identically on the remaining U Key Invert & V Key Invert component versions. However they are directed at the U/B-Y (blue) color component and V/R-Y (red) color components respectively. Adjustment and effects are the same as explained above for Y Key Invert (brightness/grey-scale).

COMMON KEYER OPERATIONS

This section provides step by step instructions for some common keyer operations.

Operation of the Keyer

The Keyer can take some time to master and below is a breakdown and series of simple steps to help you master the Keyer's operation

When adjusting the values, please bear in the mind the following:

The Y value is the Luminance value, so 0 is black and 255 is very bright (white).

The U value is the B-Y component. This is the difference between the Blue and the Luminance value. If part of an image is black, grey or white, then its value is 128 (being the mid-point).

The V value is the R-Y component. This is the difference between the Red and the Luminance value. If part of an image is black, grey or white, then its value is 128 (being the mid-point).

Preparation:

1. Enter the Adjust windows menu.
2. Select the Source (this will be the foreground).
3. Exit the Adjust windows menu.
4. Enter the Adjust keyers menu.
5. Ensure the Keyer is Off.
6. Set all Y, U and V min/max values to [0] [255].
7. Set all Y, U and V softness values to 0.
8. Set all Y, U and V invert values to Off.
9. Turn the Keyer On.

At this point your source image will have disappeared, since all colors have been keyed out.

Adjustment:

Knowing which color(s) you want to key out from the image, e.g. black to disappear, perform the following set of steps:

1. Increase the Y Key Min from 0 until just before the required color (Key Color) appears.
2. Decrease the Y Key Max from 255 until just before the required color (Key Color) appears.
3. Repeat steps 1 & 2 for the U and V min/max values as well.

Adjust any of the Softness values to improve the key. If your input signal is slightly noisy or if you want to soften the edges within the image, then this may require you to decrease the 'min' values and increase the 'max' values to broaden the range of colors keyed out.

At this point, only the key color should remain transparent.

INPUT ADJUST GROUP

The Input Adjust menu group accesses the parameters associated with the processing amplifiers used for each input (RGB, CV, YC, etc.). They allow you to fine-tune an incoming signal to optimize its color, brightness or even sharpness. Not all settings are available for all input type. It is recommended that you Store your settings once you're happy with them in readiness for future use.

Input: RGB1 Input to adjust	[RGB1]
--	---------------

This menu item selects the input connection for which you want to make adjustments to. As in the image above, changes will only be made to the source connected to RGB1. Once the selection has been made, all changes made using the following operating parameters will only apply to the selected input.

NOTE: Selection of a CV/YC input will reveal different menu items that allow adjustments beyond those used for RGB inputs. The menu discussions that follow relate first to RGB inputs, then to CV / YC type inputs.

RGB INPUT SUB MENU ITEMS

Input: RGB1 Autoset status	[Inactive]
---	-------------------

Once the Autoset sense setting has been made, this menu item is accessed and activated. The Autoset sense utility will then correct the pixel phase and then position the Top Left portion of the image and the Bottom Right portion of the image. Once complete it then resume inactive status.

Input: RGB1 TL pos. adj.	[0] [0]
---	--------------------

This menu item allows manual positioning of the Top and Left portion of the image. It is used to ensure that the input signal is captured correctly, eliminating any black borders. These settings are often used to correct the position of a PC signal on an input, or to eliminate any undesired noise at the top or bottom of a PAL or NTSC video input.

Input: RGB1
BR size adj. [01]

This menu item allows manual positioning of the Bottom and Right portion of the image. These settings are often used to correct the position of a PC signal on an input, or to eliminate any undesired noise at the top or bottom of a PAL or NTSC video input.

Input: RGB1
On Source Loss [Blue]

This setting determines output behavior when a poor video source or loss of video occurs and how the display will look. The choices are:

- SHOW- leaves the image and shows all the image noise and breakup
- FREEZE- displays a still frame of the last good image
- BLUE- displays the typical blue screen on video loss
- BLACK- same as BLUE except for a black display.
- REMOVE- removes video information including sync from the output. The output appearance will depend on how the display handles a video loss or poor signal.

Input: RGB1
Audio input Number [1]

This menu item selects the desired Audio input for use with the active video source, allowing an audio-follow-video function. This is only functional with the MAS-6100A.

The default for the first 4 video inputs is to assign each video input an audio input from 1 to 4. For example, video input 1 receives audio input1, video input 2 receives audio input 2 etc. However this can be easily changed. You could have all video inputs using the same audio input by setting the 'Audio input' value for all video inputs to the desired audio input value.

Input: RGB1
Input pixel phase [16]

Since an image pixel is a very small element of the total image, it's possible for your unit's Analog to Digital converters to wrongly sample the picture on the edge of each pixel thereby losing image resolution and creating image noise. The Input pixel phase adjustment allows you to change the position (from 0 to 31) where the pixels are sampled, relative to the horizontal sync signal.

To make this adjustment, select an RGB input and then provide an image from that source with fine detail, preferably with very sharp vertical lines. Adjust this value until you see the sharpest image. Alternately, adjust this value to give the worst (noisiest/softest) image, and then add or subtract 16 to get the optimum value.

Note that the AUTOSET function (for RGB inputs only) will attempt to automatically work out the best value for this setting.



There are several types of signals that are called RGB signals as a generic term. Each has slightly different characteristics that set it apart from similar RGB signals – such as how the synchronization signal is sent. This menu item lets you set the input type to use.

Available options are:

RGBHV - Red, Green, Blue image plus Horizontal and Vertical Sync

RGBS - Red, Green and Blue plus a single TTL level Sync signal

RGsB - Red, Green and a Blue image plus a sync signal superimposed on the Green channel

YUV - also know as YPbPr and common for 720p and 1080i formats, where a sync signal is present on the Y signal



This menu item lets you adjust the individual RGB or YUV/YPbPr signals, in case one component is at a different contrast to other, or if they all need to be boosted or lowered.



An interlaced input consists of two fields separated in time. Both fields are required in order to make up the full resolution input image, but since they are sent one after the other, a moving image will have “motion artifacts” if the two fields are simply combined together. The most common artifact is a blurring at the point of maximum movement within an image. Your unit provides some tools to minimize the effects of de-interlacing of an image

The following options are available for this menu item:

Mode	Function
Normal	The two interlaced fields are simply combined together. This will often show artifacts on moving images, but can be used when the input is known to be still.
Auto	Automatically selects Film 3:2 or Medium Range Motion Compensation (M. Comp Med.) depending on whether Film Mode is detected or not. For 1080i sources, a special de-interlacing mode is selected to eliminate combing effects.
Film 3:2	Enables 3:2 pull down conversion of the incoming NTSC video. (This option is ignored if the source is not NTSC video).
M.Comp Low M.Comp Med. M. Comp High	Enables Pixel Adaptive Motion Compensation. Three levels are available with 'Low' providing the least compensation for Motion and 'High' providing the most compensation.

Input: RGB1 Diagonal Interp.	[Off]
---	--------------

This menu item allows the user to specify whether the input has diagonal interpolation applied to it when de-interlacing occurs. This reduces 'jagged' artifacts on moving images, however is not suitable for noisy sources where the noise could be mis-interpreted as a diagonal or sloping element of the picture.

Input: RGB1 F. swap	[Off] Offset [-4+3]
--------------------------------------	----------------------------

This menu item is only available when "Advanced menus" in the System Settings Group is turned on. It can correct for an interlaced source with abnormal odd/even field characteristics. With F. swap "ON", the odd and even fields will be swapped. The "OFFSET" adjusts the video line offset for the odd field relative to the even field. These setting options may be useful with certain graphics cards where odd and even fields are swapped.

Normal video sources will not require the use of this adjustment and should be left "OFF".

CV & YC INPUT SUB MENU ITEMS

Of the above Input Menu items, the Autoset sense and Autoset status functions, RGB type and Pixel phase are specific to RGB signals only. The rest of the Input menu items function with RGB, CV or YC type signals. In addition, there are four additional Menu items that are only used with CV or YC type signals and these are explained below:

Input: YC1
Bright [100] **Contrast [100]**

Adjusts the Brightness and Contrast of the image to your requirement.

Input: YC1
Color [100] **Hue [0]**

Color is the amount of color saturation present in the image. Hue is the color “tint” parameter and the adjustment range is +90 degrees through to -90 degrees with 0 being the default.

Input: YC1
Sharpness **[0]**

Within limits, you can enhance or soften the appearance of detail within an image. The Sharpness values go both negative and positive, with 0 being the default. Note that over-enhancing an image has the side effect of making it appear to be noisy and under-enhancing an image gives the appearance of poor video quality.

Input: YC1
Luma delay **[0]**

On occasion, a video input will have the color portion of the signal offset from the luminance portion. If you’ve ever seen a poor quality comic book that has the outline of the cartoon character’s head in one place on the page but the flesh tones for the head offset slightly, you are seeing the print equivalent of Luminance to Chrominance Phase Delay. Fortunately, your unit provides a way for you to make the two signals occur at the same time on the selected image. The adjustment range provides both positive and negative levels of delay with 0 being the default.

TRANSITION ADJUST GROUP

The Transition Adjust group selects and adjusts the behavior and duration of the CUT, FADE and WIPE transitions. The sub menus will vary depending on which transition is selected as described below.

Adjust Transition
Transition **[CUT FADE WIPE]**

Select one of the three transition types. This becomes the current transition when a source is selected. The default is the FADE transition.

CUT and FADE SUB MENU ITEMS

Adjust Transition Transition time	[0-999.9]
--	------------------

This setting adjusts the duration of the FADE transition. It has no effect if CUT is selected

WIPE SUB MENU ITEMS

Adjust Transition Transition time	[0-999.9]
--	------------------

This setting adjusts the duration of the WIPE transition.

Adjust Transition Wipe Type	[Fade]
--	---------------

There are a variety of Wipe patterns to choose from and include:

- Left to Right Curtain
 - Right to Left Curtain
 - Up Down Curtain
 - Down Up Curtain
 - Diagonal
 - Diamond
-

Adjust Transition Wipe Size	10-2000]
--	-----------------

This setting adjusts the thickness of the transition bars. The lower settings will yield a tighter bar pattern with many bars. Higher settings will produce wider bars.

ADJUST RESOLUTIONS GROUP

NOTE: The Adjust Resolutions Menu Group only appears when the Advanced Menus function is turned on within the System Menu Group. To turn it on, go to the System Menu Group and then proceed to the item that says “Advanced Menus”. Turn the function ‘On’, exit the Systems menu and return to this menu structure.

The Resolution Database is used by your unit to identify any incoming video signal and is also used to create an output resolution. It is therefore a very important part of the unit’s infrastructure.

IMPORTANT CAUTIONARY INFORMATION:

DO NOT ADJUST THESE ITEMS UNLESS YOU’RE CERTAIN YOU KNOW WHAT YOU’RE DOING! THE ONLY METHOD TO UNDO CERTAIN CHANGES IS TO UPDATE THE FIRMWARE.

TRY USING THE AUTOSET, SHRINK, SHRINK POS, TL & BR ADJUSTMENTS FIRST.

Making adjustments here risks creating a non-standard resolution that is not displayable on a monitor. The resolutions and values within the database are industry standards and should not normally be altered by the user. That said, there might be times when it is necessary to create a custom resolution with specific parameters. If circumstances require you to make such a change, please read the following specific notes:

1. Any changes made to this database take effect instantly and are also stored immediately in non-volatile memory.
2. Since this database is used for both input and output image processing, altering a resolution that is used for both (e.g. 1024x768 input and 1024x768 output) may give undesired effects.

800 x 600 60 Hz Image to adjust
--

[17]

Change the value to select resolution you want to alter.

NOTE: Typically, the image number currently being used for input or output would be already be selected otherwise immediate feedback to your changes will not be available via your monitor.

800 x 600 60 Hz Interlaced

Off]

This adjustment specifies whether the image is interlaced or progressive scan. It toggles simply On or Off, so there are no flashing brackets.

800 x 600 60 Hz
H,freq,crse **[37,879] KHz**

The H freq.crse (Horizontal Sync Frequency - Course) adjustment provides the option for changing the Horizontal Sync timing Frequency in 100 Hz steps.

800 x 600 60 Hz
H,freq,fine **[37,879] KHz**

The H.freq.fine (Horizontal Sync Frequency) adjustment provides the option for changing the Horizontal Sync timing Frequency in 1 Hz steps. Use this option to fine tune after using the course adjust. Please note that the internal sync generator may be unable to generate the exact frequency you want.

800 x 600 60 Hz
Clks/l [1056] = **40,000Mhz**

This option changes the total number of image pixels on one line of monitor video including the Horizontal sync pulse and blanking time. This is normally in a multiple of 8. It is very important to get this value correct, or many digital display devices, such as TFT monitors, will display an image with an odd moiré effect – such as soft vertical bands spread evenly across the image.

800 x 600 60 Hz
Lines/f [628] = **60,317 Hz**

This menu controls the total number of lines of video present in the image which includes the vertical Sync pulse, the blanking period and the active video. Changing this option affects the final vertical sync frequency.

800 x 600 60 Hz
H/V active **[800] x 600**

A video frame includes both the active area, the portion of the image normally containing useful visual information, and a resolution value for a given display standard which only expresses the number of pixels visible in an image.

The well-known 800 x 600 computer resolution standard simply means that there are 800 pixels/line visible horizontally and there are 600 lines visible vertically. This item provides a way to change the number of active pixels and lines.

800 x 600 60 Hz
H/V Start **[88] x 23**

There is a period of time between the end of the Horizontal Sync pulse and the start of Active Video. This portion of the waveform signal is called the “Back Porch”, a term originating with the television broadcasting industry and its RS-170A specification. In practice, this will control where the video image starts on the left side of the monitor without changing the width of the sync pulse itself (another way to control where the image area starts). The two parameters control where the back porch is positioned and they interact to a degree.

NOTE: By adjusting these parameters, you control the start of the back porch (with respect to the trailing edge of Horizontal Sync) and also its width. The place where the Back Porch begins with respect to the Horizontal Sync pulse and the width of the Back Porch have a direct bearing on where the active (visible) portion of the image begins. Do not attempt this adjustment without monitoring the results with an oscilloscope.

800 x 600 60 Hz H/V Sync	[128] x 4
---	-------------------

There are standards for all current computer and broadcast resolutions that specify the correct width of both Vertical and Horizontal synchronizing pulses. If you are creating a special, non-standard resolution, you may wish to adjust the pulse width to fit your new requirements. The H/V Sync screen is where that is accomplished.

NOTE: Like the H/V Start adjustment, you must use an oscilloscope when making these adjustments so that you know exactly how many milliseconds or microseconds of pulse width you have created. The numbers shown are relative numbers and not an actual time measurement.

800 x 600 60 Hz Sync polarity	[+H+V]
--	---------------

Sync can be either negative polarity or positive polarity. To further complicate things, it is possible that you may want to make the Horizontal Sync polarity different from the Vertical Polarity. This control allows you to make that change. There are four possible selections:

- | |
|------|
| +H+V |
| -H+V |
| +H-V |
| -H-V |

SYSTEM SETTINGS GROUP

The final Menu Group is for adjustments of System parameters. The “System” in this case means the unit’s functions that are generally unrelated to individual inputs, outputs or any of the various production features.

System Settings
FSR version # xxx

This screen is an informational screen. Should you require technical assistance with your unit, the technical support personnel may request that you read the contents of this screen to them during the support call.

System Settings
SW date: 2007-7-11

This is an information page showing when the currently installed software was released. The information is useful to the user as he or she compares the date to the support web site information describing the current software release.

NOTE: Normally, the user will examine the added features of each new software release and determine if an update is worth doing in their particular operation. The greater period of time between the current date, and the date shown for the currently installed software, the greater the likelihood that there are useful changes and improvements present in the new release.

System Settings
ID# 00-00-00-00-00-00

The TAC number is a unique identifier for the unit and is for future use.

System Settings
Select to Save Current

This screen provides a quick and easy way to store all current operating parameters. The unit will remember the set up you are currently using at the time of data storage and also when you next apply power. To store the current settings, press and release the control button.

System Settings
OSD on power up [On]

This parameter controls whether the ‘welcome’ screen is displayed or not on power up – it can be disabled as

required. This is useful when a unit is installed as part of an overall system.

System Settings Advanced Menus	[Off]
---	--------------

When turned on, the previously explained Adjust resolutions menu structure is exposed. The default condition is ‘Off’, to prevent accidental changes.

System Settings RS232 baud rate	[57600]
--	----------------

This menu item allows the adjustment of the serial baud rate used for RS-232 communications. The rate can be adjusted to 9600, 19200, 28800, 33600, 38800, 57600 and 115200. (This adjustment is provided for those instances where you wish to use the RS-232 control system for your own purposes.) The default baud rate is 57600.

System Settings Buzzer	[On]
---	--------------

The screen labelled ‘Buzzer’ is actually the control for turning the “Beep” “On” or “Off”. Normally this is left in the “On” position to provide positive feedback that your data entries and parameter changes have been accepted.

System Settings Resolutions	88
--	-----------

This screen is an informational screen showing the total number of the defined resolutions in the resolution database. Future firmware releases may increase the total number of resolutions defined in the database.

System Settings Power cycles	41
---	-----------

Power Cycles refers to how many times the unit has been powered since it left the factory. This is an informational screen. No action is taken regardless of the value shown here, however some users have an equipment cleaning or specification audit procedure and this information may be useful to those users.

System Settings Firmware updates	11
---	-----------

Indicates the total number of times the firmware has been changed over the life of the unit. It is quite possible for this to be more than 1, as a unit undergoes numerous tests during production.

System Settings Hours in Use

877

This is another informational display for usage audit purposes. It displays the number of hours the unit has been in operation..

IR REMOTE CONTROL COMMANDS

Files containing the CCF format IR command strings for this unit are available via download from the FSR website at www.fsrinc.com. They are available for use with a variety of universal remote control devices as well as AMX and Crestron Control systems. A pre-made template for FSR Room Navigator control of the MAS-6100 is also available on the FSR website along with serial commands.

The IR receiver port is located to the far right of the MAS-6100 front panel and is labeled "IR".

PINOOTS AND CABLING

HD15 CONNECTOR

- 1.Red / Pr / R-Y
- 2.Green / Y
- 3.Blue / Pb / B-Y
- 4.ID2 (input & output linked)
- 5.GND
- 6.GND
- 7.GND
- 8.GND
- 9.No connection
- 10.GND
- 11.GND on input, pulled high on output (used for auto-termination)
- 12.SDA (input & output linked)
- 13.H sync (or composite sync for RGBS)
- 14.V sync
- 15.SCL (input & output linked)

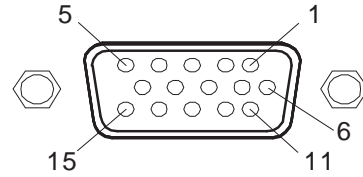

HD-15 Input Connector Pinout
(as viewed from rear of unit)

4 PIN MINI-DIN S-VIDEO CONNECTOR (YC) INPUT

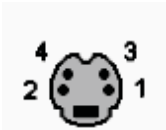

Cable Type: Standard 4 pin S-Video to two BNC male cable.

Maximum Recommended Length: 35 ft

Pin	Name	Description
1	GND	Ground (Y)
2	GND	Ground (C)
3	Y	Intensity (Luminance)
4	C	Color (Chrominance)

MAS-6200 AUDIO INPUT CONNECTOR WIRING

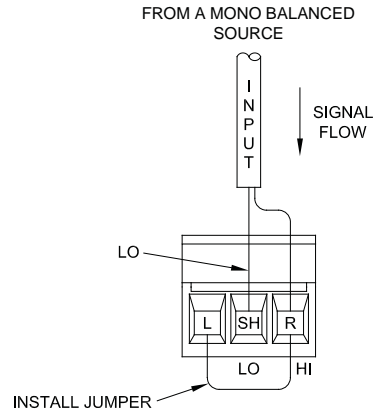
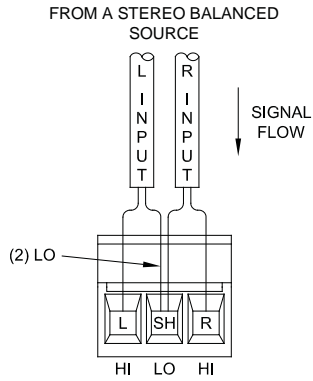
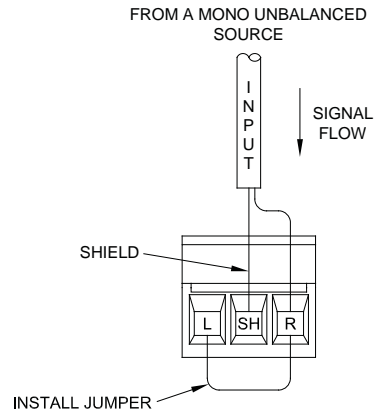
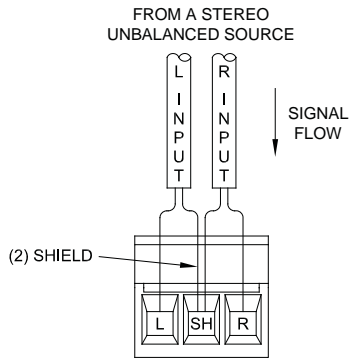

AUDIO WIRING

MAS-6200 AUDIO OUTPUT CONNECTOR WIRING

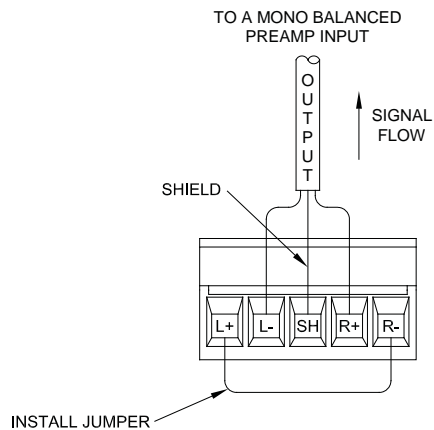
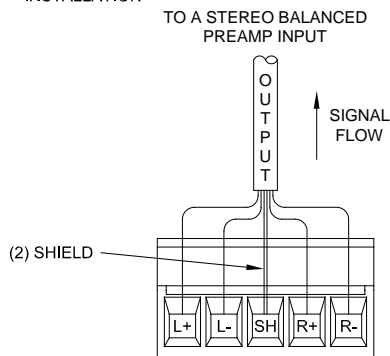
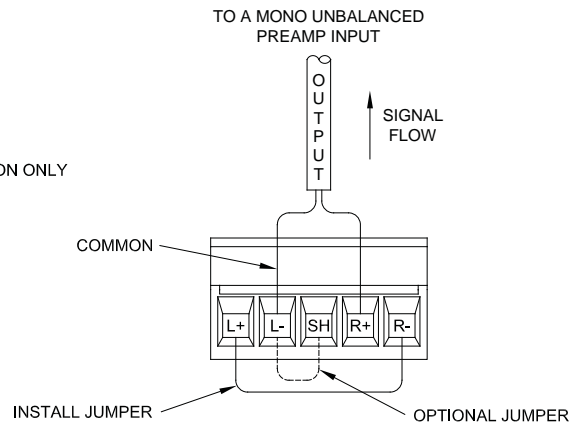
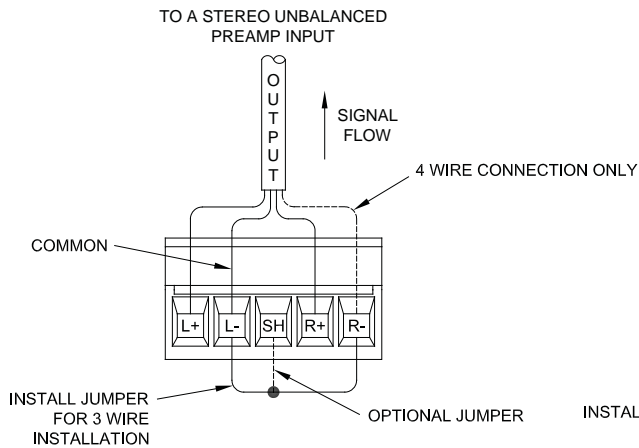

DB9 CONNECTOR

Please see the MAS-6100 serial protocol manual included with the product for serial commands and other details on RS-232 control.

RS232 / D9 socket

- 1.N/C
- 2.TX (Transmit data)
- 3.RX (Receive data)
- 4.N/C
- 5.GND (Signal return)
- 6.N/C
- 7.CTS (Clear to send)
- 8.RTS (Request to send)
- 9.N/C

RS-232 HARDWARE CONFIGURATION	
BAUD RATE	57600
DATA BITS	8
STOP BITS	1
PARITY	NONE
FLOW CONTROL	NONE

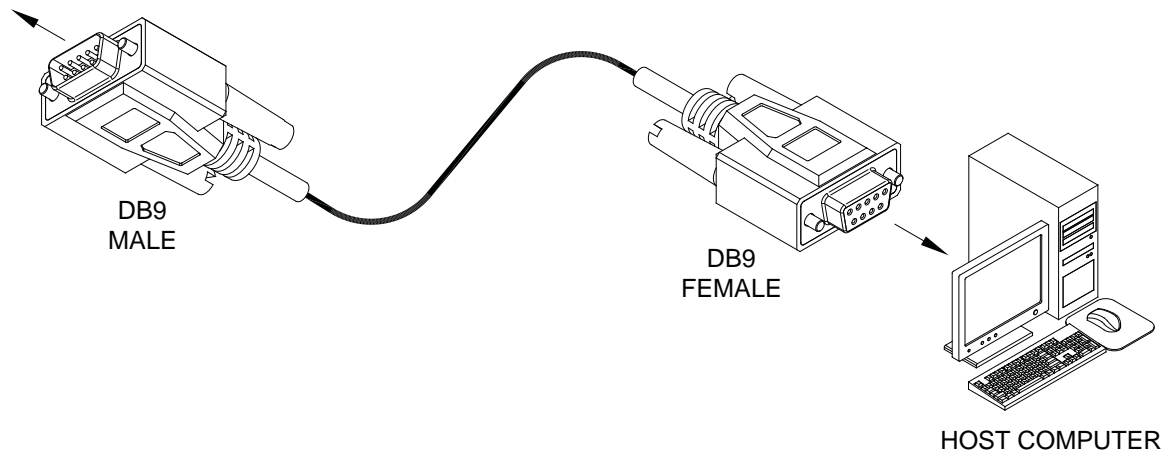
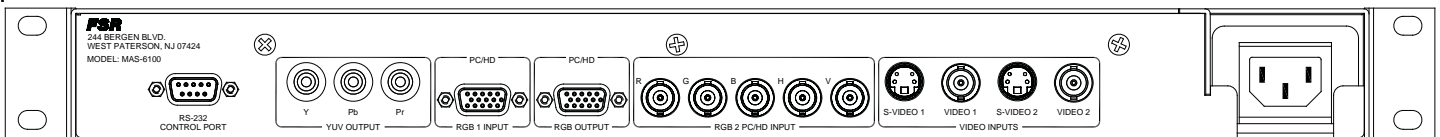

MAS-6100 RS232 CONTROL SPECIFICATION

This section outlines how to control a unit via RS232 using ASCII-based commands. It details how to send and receive serial data to perform many of the functions that a user has access to on the unit.

COMMUNICATION PROTOCOL BASICS

Packets of ASCII data containing hexadecimal numbers are exchanged between the unit and controller via an RS232 or IP link (you cannot use both at the same time).

The RS232 standard is 57600 baud, 8 bits, no parity and 1 stop bit, although this can be changed by the user.

No flow control is used - however all control packets start with an ASCII 'F', end with carriage-return (13 decimal, 0x0D hex) and all such packets sent to the unit will be acknowledged (thereby providing software handshaking). Note that a line-feed (LF 10 decimal, 0x00A hex) should not be sent.

It may take around 30ms (0.03 seconds) for an RS232 command to be actioned and acknowledged.

ASCII-hex data is used where a number is encoded into its hexadecimal equivalent with leading zeros – e.g. Where '00' is decimal value 0, '80' is decimal 128 and 'FF' is decimal 255. In other words, two characters are sent for each byte encoded.

Any gap of more than 1 second between the characters of a control command sent will cause a time-out - and previous characters sent will be lost.

Write packets (sending command functions to the unit) are always 20 characters long (including a carriage return at the end). The unit will respond with a full 20 character message indicating what has changed. This returned payload will reflect the actual value of the parameter changed. If the user requests a value out of bounds then the limit value is used, and the payload will then reflect the limited value used.

Read packets (sent to request information from the unit) are always 14 characters long (including a carriage return at the end), the response from the unit will be a 20 byte message with the Write flag (since it is 'writing' the value back to the host) and the ACK flag set.

The ACK flag will be returned as 0 if the command is invalid for some reason – for example a bad FUNCTION, WINDOW, OUTPUT or PAYLOAD value. An ACK=0 message will be otherwise identical to the one you sent, so you know exactly which message has the error.

Any changes made to the unit using the front panel controls will also cause the full 20 byte message to be sent indicating the change that has occurred, thus enabling a program to stay 'in-sync' with the unit. In some cases (such as the execution of a macro) multiple 20 bytes messages will be sent indicating all the parameters that have been changed.

Only one message should be sent to the unit, another message can't be sent until a specific response is received from the unit (the user should look for a message with the same WINDOW, OUTPUT and FUNCTION values as they sent). If no message is received back within 1 second, there is likely to be a hardware communication problem (or wrong baud rate, etc.).

If absolutely required, to simplify programming the user may send packets one after the other with around 100ms (100 milliseconds) between each one. However, this will not work for all packets (such as Zooming into Testcards or changing Logos) since this will cause the unit's micro-controller to be busy, so the user must

experiment and satisfy themselves that this is possible.

Checksums

The protocol requires checksums on all commands. The checksum is the sum of all previous bytes (excluding the SOP 'F' character). The checksum is calculated on the hex value of the two ASCII bytes. For example, the command "F0400410082000001C8" has the checksum of C8 (04+00+41+00+82+00+00+01=C8). A short-cut for debugging allows the checksum to be replaced by 2 question marks, so in the previous example you could send F0400410082000001??. Instead. This is purely for test and debugging - you should normally use a checksum to ensure data validity.

Carriage Returns

Each packet that is sent to or received from the MAS-6100 is terminated with a carriage return. Carriage return has a value of 13 decimal, but is sent as a hex byte 0x0D. It will be represented in this document as <CR>.

PACKET FORMAT

Read Packets

Below is a representation of data bytes in a single packet for a 'Read' to the unit to get a value:

SOP	CMD	CHA	WINDOW/FUNCTION	OUTPUT	FUNCTION	CS	EOP
-----	-----	-----	-----------------	--------	----------	----	-----

The table below details the function of each part of the packet:

Packet part	Function
SOP (Start of packet)	This is always the ASCII letter 'F' to indicate the packet start.
CMD (Command)	ASCII-hex byte to indicate the type of command being sent. Each bit in the byte has a different function. Bit 7 = Write (0) or Read (1) request. Messages from the unit are always Writes. Bit 6 = ACK bit. Should be set to 0 for messages to the unit. ACK=1 returned means message was okay. ACK=0 returned means an error was present in the message. Bit 5:3 = 0 Reserved for future use. Bit 2 = 1 This bit *must* be set. Bit 1:0 = 0 Reserved for future use.
SOURCE	This byte has multiple uses, and defaults to 0 unless used for: <u>SOURCE</u> Byte to indicate the source channel to be altered (if appropriate). 0x10 = RGB1 0x11 = RGB2 0x30 = VIDEO1 0x31 = VIDEO2 0x40 = S-VID1 0x41 = S-VID2
WINDOW	Bit 7 = 0 (Reserved). Bit 6..0 = Window 'A' is sent as '41' since 0x41 is ASCII for 'A'.
OUTPUT & FUNCTION HIGH	Bit 7..4 = 0 Bit 3..2 = Reserved (set to 0). Bit 1..0 = Bits 9 & 8 of the function code. (Remainder of bits [7..0] are in FUNC LOW.) Example: If the function code is 0x234, then these bits are 0x02.
FUNCTION LOW	ASCII-hex byte to indicate the lowest 8 bits of the actual function to set or receive.. A later table details all the functions available.
CS	ASCII-hex, see above.
EOP	<CR>

Write Packets

Below is a representation of data bytes in a single packet for a 'Write' to the unit to set a value:

SOP	CMD	CHA	WINDOW	OUTPUT/FUNCTION	FUNCTION	PAYLOAD x 3	CS	EOP
-----	-----	-----	--------	-----------------	----------	-------------	----	-----

The table below details the function of each part of the packet:

Packet part	Function
SOP (Start of packet)	This is always the ASCII letter 'F' to indicate the packet start.
CMD (Command)	ASCII-hex byte to indicate the type of command being sent. Each bit in the byte has a different function Bit 7 = Write (0) or Read (1) request. Messages from the unit are always Writes. Bit 6 = ACK bit. Should be set to 0 for messages to the unit. ACK=1 returned means message was okay. ACK=0 returned means an error was present in the message. Bit 5..3 = 0 Reserved for future use. Bit 2 = 1 This bit *must* be set. Bit 1..0 = 0 Reserved for future use.
SOURCE	This byte has multiple uses, and defaults to 0 unless used for: <u>SOURCE</u> Byte to indicate the source channel to be altered (if appropriate). 0x10 = RGB1 0x11 = RGB2 0x30 = VIDEO1 0x31 = VIDEO2 0x40 = S-VID1 0x41 = S-VID2
WINDOW / LOGO	Bit 7 = 0 (Reserved). Bit 6..0 = Window 'A' is sent as '41' since 0x41 is ASCII for 'A'
OUTPUT & FUNCTION HIGH	Bit 7..4 = 0 Bit 3..2 = Reserved (set to 0). Bit 1..0 = Bits 9 & 8 of the function code. (Remainder of bits [7..0] are in FUNC LOW.) Example: If the function code is 0x234, then these bits are 0x02
FUNCTION LOW	ASCII-hex byte to indicate the lowest 8 bits of the actual function to set or receive. A later table details all the functions available.
PAYLOAD x 3 bytes	A series of three ASCII-hex bytes carrying the data to send, MSB first. Example: '000001' is 1 in decimal, '010000' is 65536 in decimal, and 'FFFFFF0' is -16 in decimal.
CS	ASCII-hex, see above.
EOP	<CR>

FRONT PANEL BUTTON EXAMPLES

If the user is using the serial commands to simulate the front panel of the MAS-6100, the following commands are provided. They have been tested.

The commands are to be sent out in the following manner, with no spaces between the fields.

F4410410082000010??<CR>

Would switch the source to RGB.

Source = RGB1

SOP	CMD	CHA	WIN	OUT	FUN	PAY	CS	EOP
F	04	00	41	00	82	000010	D7	<CR>

Where:

CMD 04, Write command
 CHA 00
 WIN 41, Window "A"
 OUT 00, Output 1
 FUN 82, Change Program source
 PAY 000010, Source RGB1
 CS ??, test checksum

Source = RGB2

SOP	CMD	CHA	WIN	OUT	FUN	PAY	CS	EOP
F	04	00	41	00	82	000011	D8	<CR>

Where:

CMD 04, Write command
 CHA 00,
 WIN 41, Window "A"
 OUT 00, Output 1
 FUN 82, Change Program source
 PAY 000010, Source RGB2
 CS ??, test checksum

Source = S-VID1

SOP	CMD	CHA	WIN	OUT	FUN	PAY	CS	EOP
F	04	00	41	00	82	000040	07	<CR>

Where:

CMD 04, Write command
 CHA 00,
 WIN 41, Window "A"
 OUT 00, Output 1
 FUN 82, Change Program source
 PAY 000040, Source S-VID1
 CS ??, test checksum

Source = S-VID2

SOP	CMD	CHA	WIN	OUT	FUN	PAY	CS	EOP
F	04	00	41	00	82	000041	08	<CR>

Where:

CMD 04, Write command
 CHA 00,

WIN 41, Window "A"
 OUT 00, Output 1
 FUN 82, Change Program source
 PAY 000041, Source S-VID2
 CS ??, test checksum

Source = VIDEO1

SOP	CMD	CHA	WIN	OUT	FUN	PAY	CS	EOP
F	04	00	41	00	82	000030	F7	<CR>

Where:

CMD 04, Write command
 CHA 00,
 WIN 41, Window "A"
 OUT 00, Output 1
 FUN 82, Change Program source
 PAY 000030, Source S-VID2
 CS ??, test checksum

Source = VIDEO2

SOP	CMD	CHA	WIN	OUT	FUN	PAY	CS	EOP
F	04	00	41	00	82	000031	F8	<CR>

Where:

CMD 04, Write command
 CHA 00,
 WIN 41, Window "A"
 OUT 00, Output 1
 FUN 82, Change Program source
 PAY 000031, Source S-VID2
 CS ??, test checksum

FREEZE ON

SOP	CMD	CHA	WIN	OUT	FUN	PAY	CS	EOP
F	04	00	41	00	9C	000001	??	<CR>

Where:

CMD 04, Write command
 CHA 00,
 WIN 41, Window "A"
 OUT 00, Output 1
 FUN 9C, Freeze
 PAY 000001, On
 CS ??, test checksum

FREEZE OFF

SOP	CMD	CHA	WIN	OUT	FUN	PAY	CS	EOP
F	04	00	41	00	9C	000000	??	<CR>

Where:

CMD 04, Write command
 CHA 00,
 WIN 41, Window "A"
 OUT 00, Output 1
 FUN 9C, Freeze
 PAY 000000, Off
 CS ??, test checksum

KEY ON

SOP	CMD	CHA	WIN	OUT	FUN	PAY	CS	EOP
F	04	00	41	01	27	000001	??	<CR>

Where:

CMD 04, Write command
 CHA 00,
 WIN 41, Window "A"
 OUT 00, Output 1, Key Enable high bit (function is 127)
 FUN 27, Key
 PAY 000001, On
 CS ??, test checksum

KEY OFF

SOP	CMD	CHA	WIN	OUT	FUN	PAY	CS	EOP
F	04	00	41	01	27	000000	??	<CR>

Where:

CMD 04, Write command
 CHA 00,
 WIN 41, Window "A"
 OUT 00, Output 1, Key Enable high bit (function is 127)
 FUN 27, Key
 PAY 000000, Off
 CS ??, test checksum

LOCK ON

SOP	CMD	CHA	WIN	OUT	FUN	PAY	CS	EOP
F	04	00	41	01	0A	000001	??	<CR>

Where:

CMD 04, Write command
 CHA 00,
 WIN 41, Window "A"

OUT 00, Output 1, Lock function high bit (function is 11A)
 FUN 1A, Lock
 PAY 000001, On
 CS ??, test checksum

LOCK OFF, BGND OFF

SOP	CMD	CHA	WIN	OUT	FUN	PAY	CS	EOP
F	04	00	41	01	0A	00000	??	<CR>

Where:

CMD 04, Write command
 CHA 00,
 WIN 41, Window "A"
 OUT 00, Output 1, Lock function high bit (function is 11A)
 FUN 0A, Lock
 PAY 000000, Off
 CS ??, test checksum

BGND ON

SOP	CMD	CHA	WIN	OUT	FUN	PAY	CS	EOP
F	04	00	41	01	0A	000001	??	<CR>

Where:

CMD 04, Write command
 CHA 00,
 WIN 41, Window "A"
 OUT 00, Output 1, Lock function high bit (function is 11A)
 FUN 0A, Lock
 PAY 000002, Background on (Lock & Mix)
 CS ??, test checksum

AUTO

SOP	CMD	CHA	WIN	OUT	FUN	PAY	CS	EOP
F	04	00	41	00	FE	000001	??	<CR>

Where:

CMD 04, Write command
 CHA 00,
 WIN 41, Window "A"
 OUT 00, Output 1,
 FUN FE, Start Autoreset function
 PAY 000002, Background on (Lock & Mix)
 CS ??, test checksum

DISSOLVE (Transition Type)

SOP	CMD	CHA	WIN	OUT	FUN	PAY	CS	EOP
-----	-----	-----	-----	-----	-----	-----	----	-----

F	04	00	41	01	12	000001	??	<CR>
---	----	----	----	----	----	--------	----	------

Where:

CMD 04, Write command
 CHA 00,
 WIN 41, Window "A"
 OUT 01, Output 1, Transition type high bit (function is 112).
 FUN 12, Set transition.
 PAY 000001, Set transition type to dissolve.
 CS ??, test checksum

CUT(DISSOLVE OFF) (Transition Type)

SOP	CMD	CHA	WIN	OUT	FUN	PAY	CS	EOP
F	04	00	41	01	12	000000	??	<CR>

Where:

CMD 04, Write command
 CHA 00,
 WIN 41, Window "A"
 OUT 01, Output 1, Transition type high bit (function is 112).
 FUN 12, Set transition type.
 PAY 000000, Set transition type to cut.
 CS ??, test checksum

Other useful messages:

WIPE (Transition Type)

SOP	CMD	CHA	WIN	OUT	FUN	PAY	CS	EOP
F	04	00	41	01	12	000002	5A	<CR>

Where:

CMD 04, Write command
 CHA 00,
 WIN 41, Window "A"
 OUT 01, Output 1, Transition type high bit (function is 112).
 FUN 12, Set transition type.
 PAY 000002, Set transition type to wipe.
 CS ??, test checksum

Left to Right Wipe (Transition Type)

SOP	CMD	CHA	WIN	OUT	FUN	PAY	CS	EOP
F	04	00	41	01	45	000000	??	<CR>

L

Where:

CMD 04, Write command
 CHA 00,
 WIN 41, Window "A"
 OUT 01, Output 1, Set wipe type high bit (function is 145).
 FUN 45, Set transition type.

PAY 000000, Set wipe to left to right
 CS ??, test checksum

Other wipes:

Pay Value	Wipe type
000001	Right to Left
000002	Curtain up
000003	Curtain down
000004	Diagonal
000005	Diamond

FUNCTION LIST

These are grouped together into their associated on-screen menus.

Your unit and this manual should be used to determine the actual function of each of the following, as only the menu text is listed here. Where an equivalent menu item does not exist on your unit, then that feature is not supported on.

Function codes are given in hexadecimal and adjustment range is in decimal (but always sent as hexadecimal!).

The following table is a list of all menu functions, their related function number and valid range of adjustment.

Menu text	CHA	FUNC (Hex)	Range of adjustment (decimal)
Adjust outputs			
Lock source (connector)		149	0x10 = RGB1 0x11 = RGB2 0x30 = VIDEO1 0x31 = VIDEO2 0x40 = S-VID1 0x41 = S-VID2
Lock method		10A	0=Off, 1=Genlock, 2=BGND
Lock H Shift		14A	-4096..4096
Lock V Shift		14B	-4096..4096
Output resolution		083	1..1000
Output Enable		170	0 = Off, 1 = On
Output image type analogue		0E2	0 = RGBHV 2 = RGsB 3 = YUV
Output image type digital		16C	0 = RGBHV 3 = YUV 9 = Not available
Background Y		13B	16..235
Background U		13C	16..240
Background V		13D	16..240

CCIR Output Standard		101	0 = NTSC/PAL, 1 = PAL-M/PAL-N, 2 = SECAM
Output CV/YC IRE		133	-7.5..12.5
Output CV/YC Hue (degrees)		139	-22..22
Output SC/H Phase		085	-180..180
Output Luma Bandwidth		134	0,1,2 = Low, Medium, High
Output Chroma Bandwidth		135	0,1,2 = Low, Medium, High
Output Chroma delay		137	-4..3
PAL WSS		130	0 = Off 1 = 4:3 Full format 2 = 14:9 Letterbox centre 3 = 14:9 Letterbox top 4 = 16:9 Letterbox centre 5 = 16:9 Letterbox top 6 = >16:9 Letterbox centre 7 = 14:9 Full format 8 = 16:9 Full format
Take		11E	0->1 = Perform a Preview -> Program transition
Adjust Windows			
Program source / Window source (connector)		082	0x10 = RGB1 0x11 = RGB2 0x30 = VIDEO1 0x31 = VIDEO2 0x40 = S-VID1 0x41 = S-VID2
Window Enable		12B	0..1 = Off, On
Zoom level %		086	100..1000
Zoom level H %		103	100..1000 (only used in Advanced A/R mode)
Zoom level V %		105	100..1000 (only used in Advanced A/R mode)
Aspect ratio in		107	0.1:1..9.99:1
H/V zoom pan % (H)		09F	0..100
H/V zoom pan % (V)		0A0	0..100
Freeze		09C	0..1 = Off, On
H/V out shift (H)		0AD	-4096..4096
H/V out shift (V)		0AE	-4096..4096
Lock pixel offset		14A	-2047..2047
Lock line offset		14B	-2047..2047
Aspect Adjust		102	0..1 = Simple, Advanced
Aspect ratio		190	0..2 = Normal, Letter-box, Narrow
Flicker reduction		092	0..3 = Off, Low, Med, High
Image smoothing		0A1	0..2 = Off, Med, High
Image flip		095	0..3 = Off, Horiz., Vertical, H & V
Max fade level		10F	0..100 = Fade level %
Fade out / in		193	-1= Fade out, 1= Fade in
Layer priority		144	0..5 = Layer priority
Headphone volume		0FD	-16..15 (-16=Mute)
Adjust keys (on certain models only)			
Keyer enable		127	0.. 1 = Off, On

Y key min/max (min)		0AF	0..255
Y key min/max (max)		0B2	0..255
Y key Softness		121	0..255
Y key Invert		122	0.1 = Off, On
U key min/max (min)		0B0	0..255
U key min/max (max)		0B3	0..255
U key Softness		123	0..255
U key Invert		124	0.1 = Off, On
V key min/max (min)		0B1	0..255
V key min/max (max)		0B4	0..255
V key Softness		125	0..255
V key Invert		156	0.1 = Off, On
Swap fore / background		144	0.1 = Off, On
E.blnd guides		18F	0.2 = Off, Auto, On
E.blnd size H		18B	0.. limited by H width
E.blnd size V		18C	0.. limited by V height
E.blnd gamma H		188	1..15 1=0.1, 15=1.5
E.blnd gamma V		18D	1..15 1=0.1, 15=1.5
E.blnd compensation		198	0..99
Adjust sources			
Source to adjust		116	0x10 = RGB1, 0x11 = RGB2 0x30 = VIDEO1, 0x31 = VIDEO2 0x40 = S-VID1, 0x41 = S-VID2
Autoset	10..1F	FE	1= Start Autoset procedure
Autoset Sense	10..FF	FF	0..3 = Low, medium, high, v.high
Field swap	10..FF	C9	0.1 = Off, On (swaps odd/even fields)
Field Offset	10..FF	196	0.7 = -4..+3 (defaults to 4 = 0)
Testcard	F0..F1	0DC	0..10
TL pos. adj. (left)	10..FF	0B6	-100..100
TL pos. adj. (top)	10..FF	0B7	-100..100
BR size adj. (right)	10..5F	0DE	-100..100
BR size adj. (bottom)	10..5F	0DF	-100..100
Audio input	10..FF	0D0	0..3 = Channels 1 .. 4
Audio vol	10..FF	0CF	-16..15 (-16=Mute)
Bal	10..FF	0D1	-15..15
Input pixel phase	10..5F	091	0..31
RGB input type	10..1F	0C1	0 = Auto 1 = D-RGB 2 = D-YUV 3 = A-RGB 4 = A-YUV
RGB contr. (red)	10..1F	0C5	75..150
RGB contr. (green)	10..1F	0C6	75..150
RGB contr. (blue)	10..1F	0C7	75..150
De-int.	10..FF	0B8	0.5 = Normal, Auto, Film 3:2, M.comp.low, M.comp.med., M.comp.high
(Film mode detected)	10..FF	0E3	0.1 = Not detected, Detected
Bright	30..5F	0BB	0..180

Contrast	30..5F	0BC	0..180
Saturation	30..5F	0B9	0..180
Hue	30..5F	0BA	-180..180
Sharpness	30..5F	080	-7..+7
Luma delay	30..5F	0BD	-4..3
Adjust transitions			
Transition type		112	0 = Cut, 1 = Dissolve, 2 = Wipe
Switching fade time		0F5	0 (off) to 50 (5.0 seconds)
Wipe type		145	0 = Left -> Right 1 = Right -> Left 2 = Up -> Down 3 = Down -> Up 4 = Diagonal 5 = Diamond
Wipe Size		146	10..2000, 1000 = Full Screen
Adjust resolutions			
Note: You MUST set the 'Image to adjust' value to the correct value first, and only then change the other values - otherwise you may be adjusting the wrong entry. The user should not adjust the 'Image to adjust' entry using the front panel while also accessing it via RS232			
Image to adjust		081	1..1000
Interlaced		0CA	0..1 = Off, On
H.freq.crse		0BE	10000..200000
H.freq.fine		0BF	10000..200000
H/V active (H)		096	64..2047
H/V active (V)		097	64..2047
H/V start (H)		08B	0..1023
H/V start (V)		08C	0..1023
Clks/l		08D	64..4095
Lines/f		08E	64..2047
H/V sync (H)		08F	8..1023
H/V sync (V)		090	1..1023
Sync polarity		094	0..3 = ++, +-, -+, --
System			
SW (Software version)		0D2	Read only
PT (Product type)		0C4	Read only
BT (Board type)		0C2	Read only
Advanced menus		11D	0..1, Off, On
OSD on Power up		189	0..1, Off, On
Store		0C8	Set to 1 to store
Buzzer		0CB	0..1 = Off, On
Power cycles		0D6	Read only
Firmware updates		0DD	Read only
Hours in use		0D7	Read only
Resolutions		0D8	Read only
Number of Testcards		0D9	Read only
Number of logos		14F	Read only
Board temp. (deg.C)		0CD	Read only

Air temp. (deg.C)		148	Read only
Regulators temp.(deg.C)		147	Read only
PLD temp. (deg.C)		111	Read only
Fan speed (rpm)		0CE	Read only
Led brightness		12C	0..100
RS232 Baud rate		0AB	0 = 9600 1 = 19200 2 = 28800 3 = 33600 4 = 38400 5 = 57600 6 = 115200
TAC number 0		15D	Read only
TAC number 1		15E	Read only
TAC number 2		15F	Read only
TAC number 3		160	Read only
TAC number 4		161	Read only
TAC number 5		162	Read only
Not part of menu system			
Front panel lock		0FC	0 = unlocked, 1 = locked

SPECIFICATIONS

VIDEO INPUT				
MODEL	MAS-6100 AND MAS-6100A			
SIGNAL TYPE	COMPONENT	COMPOSITE	RGB	S-VIDEO
CONNECTOR NUMBER/TYPE	TWO (VIA OPTIONAL BREAK-OUT) TO HD-15 OR 5-BNC INPUTS	ONE 1 BNC FEMALE	ONE HD-15 FEMALE ONE 5-BNC FEMALE	TWO 4 PIN FEMALE DIN
IMPEDANCE	75 OHM			
LEVEL	1 VOLT P/P			
VSWR	<1.1@250MHz	<1.3@100MHz	<1.1@250MHz	<1.3@100MHz
ISOLATION	>80dB@10MHz >65dB@100MHz	>80dB@10MHz >63dB@100MHz	>80dB@10MHz >65dB@100MHz	>80dB@10MHz >63dB@100MHz
DIFFERENTIAL PHASE	NA	0.05 degrees	NA	0.05 degrees
DIFFERENTIAL GAIN	NA	0.02%	NA	0.02%

VIDEO OUTPUT		
MODEL	MAS-6100 AND MAS-6100A	
SIGNAL TYPE	COMPONENT	RGB
CONNECTOR NUMBER/TYPE	ONE 3 RCA AND ONE HD-15 FEMALE (VIA OPTIONAL BREAK-OUT)	ONE HD-15 FEMALE and ONE 5 BNC FEMALE
IMPEDANCE	75 OHM	
GAIN	UNITY INTO 75 OHMS	
OFFSET	15mV MAX	15mV MAX
BANDWIDTH	450 MHz	450MHz
FLATNESS	+/-0.25dB 0 to 150MHz +/-1dB 150 to 400 MHz	+/-0.25dB 0 TO 150MHz +/-1dB 150 TO 400 MHz

AUDIO (MAS-6100A)	
BANDWIDTH	20 Hz to 20 kHz (+/- 0.1dB)
THD+NOISE	0.1% @20 kHz at rated max output
NOISE FLOOR	<-90dBu
CHANNEL SEPARATION	<-85dB @ 1kHz

AUDIO INPUTS (MAS-6100A)	
SIGNAL TYPE	4 stereo balanced (may be used with unbalanced sources)
CONNECTOR NUMBER/TYPE	5 pin pluggable screw terminal
IMPEDANCE	20k ohms balanced
TRIM RANGE	-15dB to +5dB in 1dB steps
GAIN RANGE	-45dB to +5dB in 1dB steps

AUDIO OUTPUT (MAS-6100A)	
NUMBER/TYPE	1 stereo balanced or unbalanced
CONNECTOR NUMBER/TYPE	One 5 pin pluggable screw terminal
IMPEDANCE	50 ohms
MAXIMUM LEVEL	600 ohms: +12dBm balanced / +6dBm unbalanced HI-Z: +14dBm balanced / +8dBm unbalanced
DELAY ADJUSTMENTS	85ms / 43ms / 21ms / 11ms—Set via rear panel dipperswitches in any combination

SYNC	
INPUT IMPEDANCE	511 ohms
OUTPUT IMPEDANCE	75 ohms
INPUT LEVEL	TTL 2.0 V minimum
OUTPUT LEVEL	5 V into HI-Z / 2.4 V into 75 ohms
OUTPUT RISE AND FALL TIME	1nS
PROPAGATION DELAY	16nS

RS-232 HARDWARE CONFIGURATION	
CONNECTOR	1 DB-9 FEMALE
BAUD RATE	38400
DATA BITS	8
STOP BITS	1
PARITY	NONE
FLOW CONTROL	NONE

POWER AND PHYSICAL	
POWER	9 VAC @500mA power supply included or 12VDC @ 300mA
CONNECTOR TYPE	2 pin pluggable screw terminals
MOUNTING	Standard 19" rack mount included
SHIPPING WEIGHT	3 lbs.

WARRANTY AND RETURN INFO

WARRANTY POLICY

This product is warranted against failures due to defective parts or faulty workmanship for a period of three years after delivery to the original owner. During this period, FSR will make any necessary repairs or replace the unit without charge for parts or labor. Shipping charges to the factory or repair station must be prepaid by the owner, return-shipping charges, via UPS / FedEx ground, will be paid by FSR.

This warranty applies only to the original owner and is not transferable. In addition, it does not apply to repairs done by other than the FSR factory or Authorized Repair Stations.

This warranty shall be cancelable by FSR at its sole discretion if the unit has been subjected to physical abuse or has been modified in any way without written authorization from FSR. FSR's liability under this warranty is limited to repair or replacement of the defective unit.

FSR will not be responsible for incidental or consequential damages resulting from the use or misuse of its products. Some states do not allow the exclusion of incidental or consequential damages, so the above limitations may not apply to you. This warranty gives you specific legal rights, and you may also have other rights which vary from state to state.

Warranty claims should be accompanied by a copy of the original purchase invoice showing the purchase date (if a Warranty Registration Card was mailed in at the time of purchase, this is not necessary). Before returning any equipment for repair, please read the important information on service below.

SERVICE AND RETURN AUTHORIZATION

Before returning any equipment for repair, please be sure that it is adequately packed and cushioned against damage in shipment, and that it is insured. We suggest that you save the original packaging and use it to ship the product for servicing. Also, please enclose a note giving your name, address, phone number and a description of the problem.

NOTE: All equipment being returned for repair must have a Return Authorization (RMA) Number. To get a RMA Number, please call FSR Service Department (973-785-4347).

Please display your RMA Number prominently on the front of all packages.

CONTACT INFORMATION

FSR Inc.
244 Bergen Boulevard,
West Paterson, NJ 07424

Tel: (973) 785-4347 · Fax: (973) 785-4207

E-Mail: sales@fsrinc.com · Web: <http://www.fsrinc.com>

