

5. COVER HAS TO BE REMOVED FROM RIM BEFORE RIM CAN BE INSTALLED TO WALL BOX.

1. BREAK STUD BRACKETS OFF METAL TREE AND INSTALL ONTO WALL BOX.

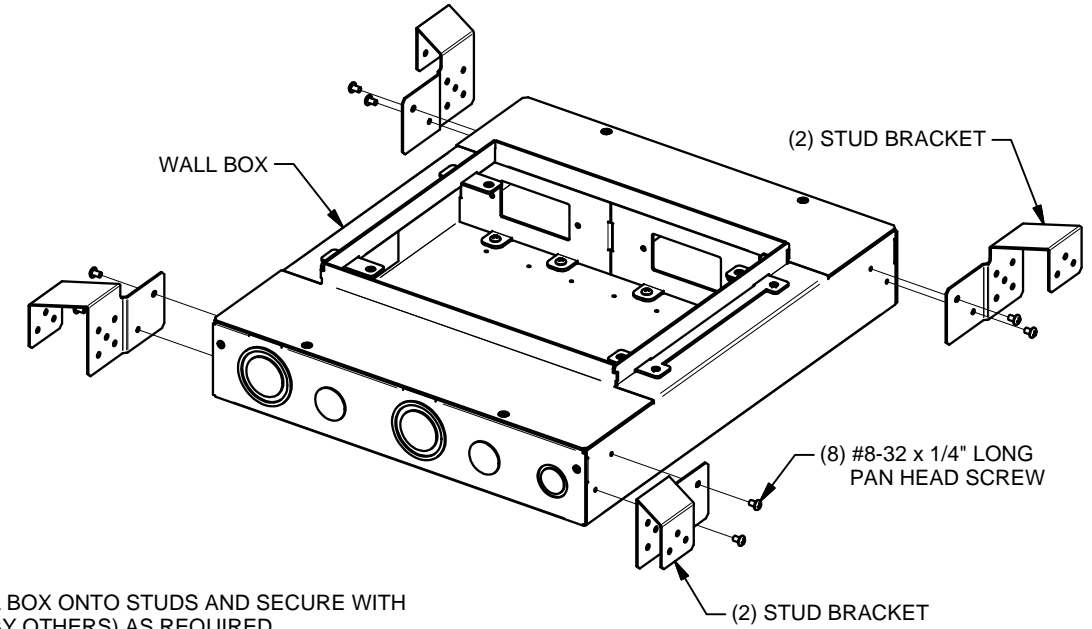

2. INSTALL WALL BOX ONTO STUDS AND SECURE WITH HARDWARE (BY OTHERS) AS REQUIRED.

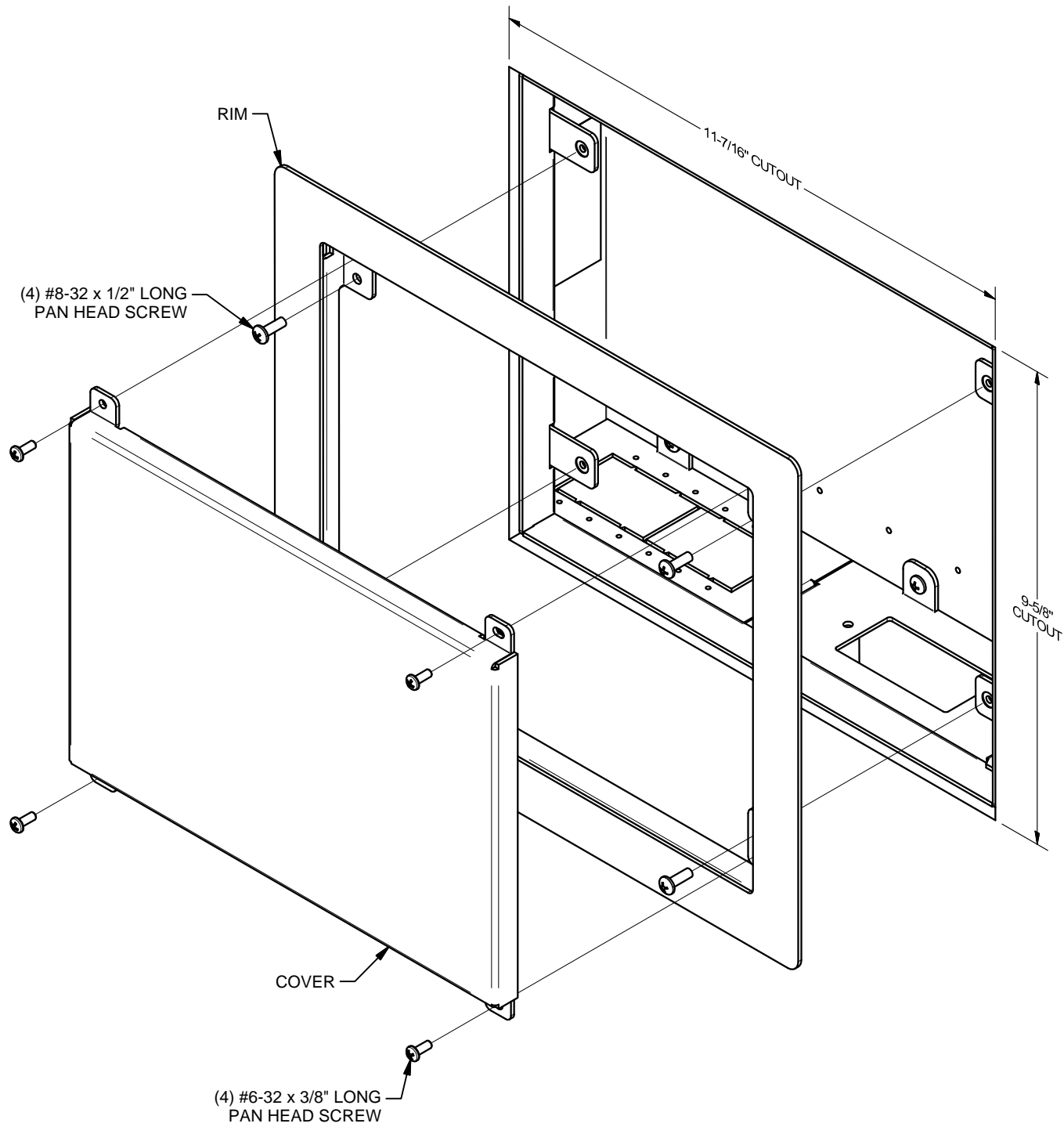
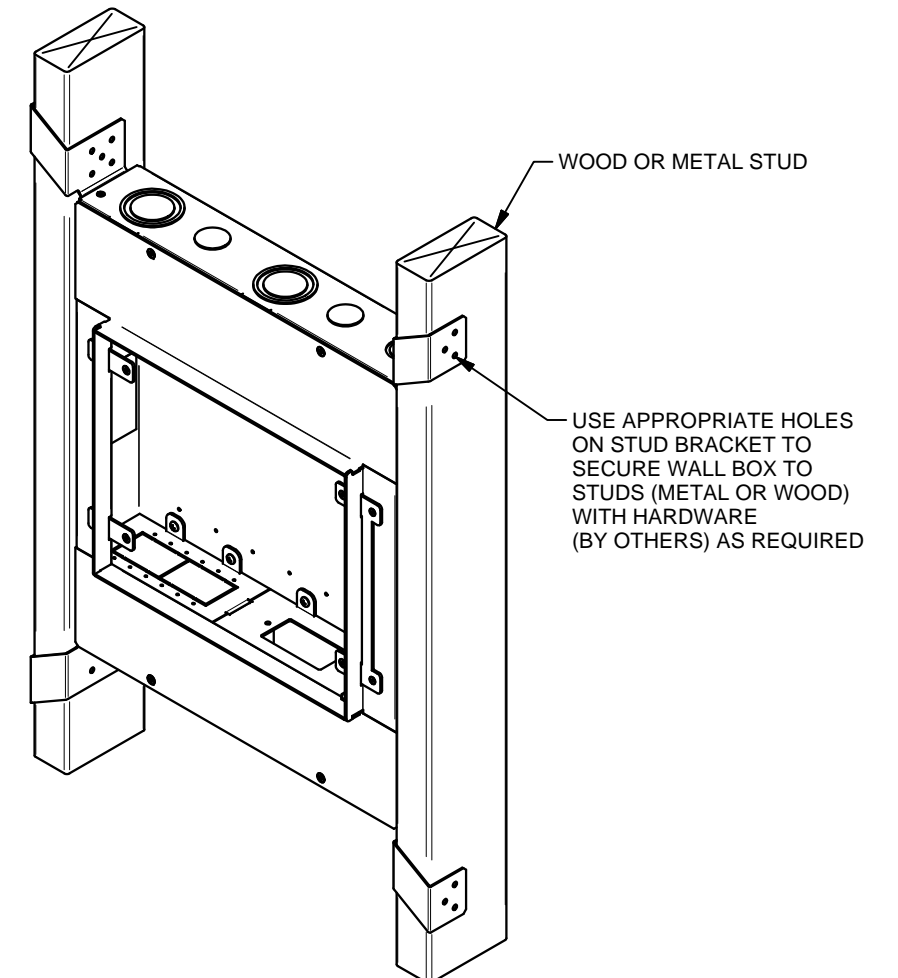

3. REMOVE BACKBOX COVERS AND ROUTE CONDUITS TO WALL BOX AS REQUIRED.

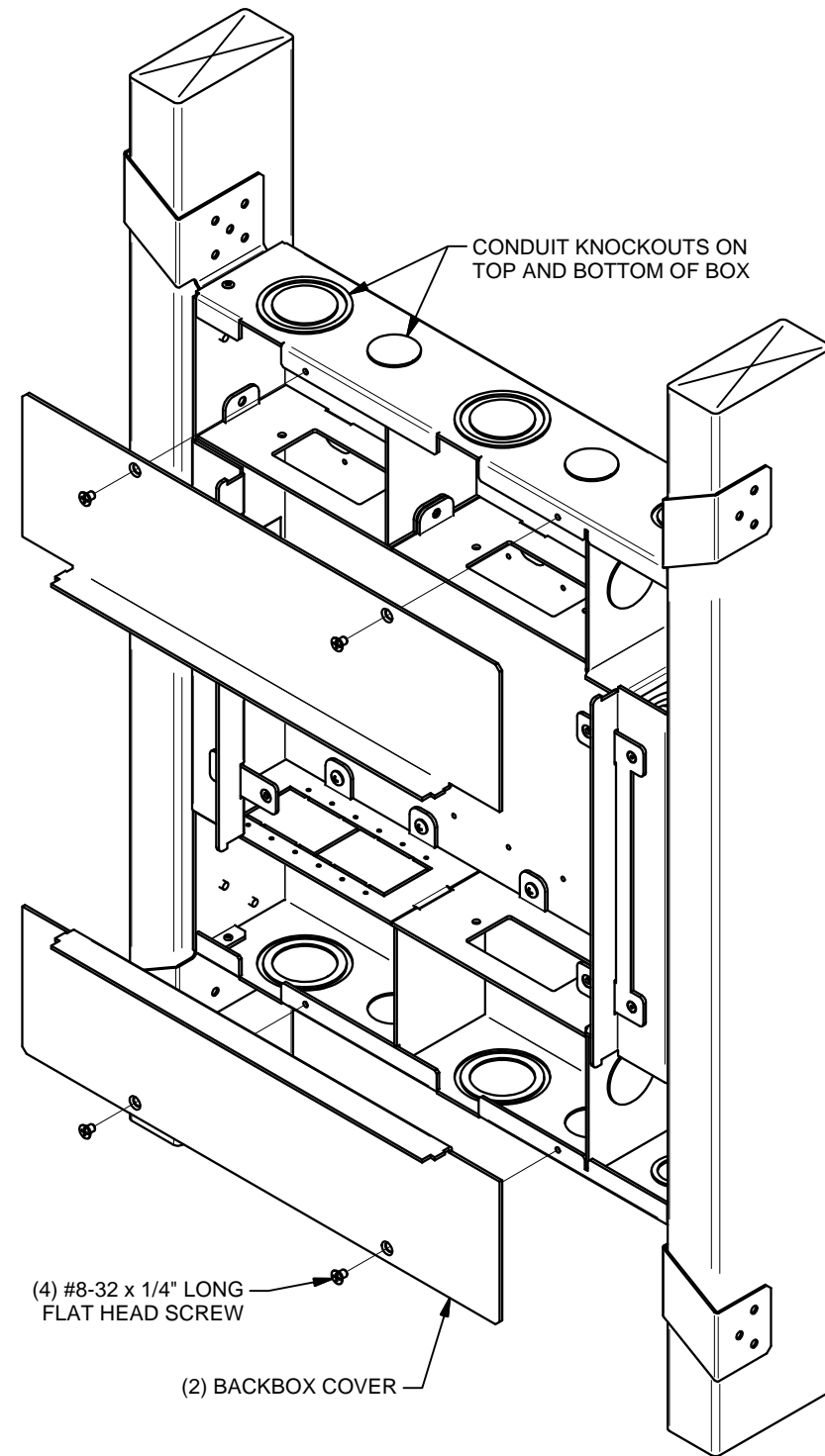

4. PER CUSTOMER SPECIFICATIONS CONFIGURE WALL BOX INTERFACE PLATES AS REQUIRED. INTERFACE PLATES AND DIVIDERS ARE REMOVABLE IF REQUIRED. REMOVE AC PANEL ASSEMBLY AND MAKE ELECTRICAL CONNECTIONS AS REQUIRED. REINSTALL BOTH BACKBOX COVERS SHOWN IN STEP 3 BEFORE MOUNTING DRYWALL.

