



HuddleVU Collaboration System



205 Westwood Ave, Long Branch, NJ 07740
Phone: 866-94 BOARDS (26273) / (732)-222-1511
Fax: (732)-222-7088 | E-mail: sales@touchboards.com



INSTALLATION AND OPERATING GUIDE



COMPLIANCE AND SAFETY

PROPRIETARY INFORMATION

All information in this manual is proprietary to and the property of FSR Inc. This publication is protected by the Federal Copyright Law, with all rights reserved. No part of this document may be reproduced, transcribed, or transmitted, in any form or by any means, without prior explicit written permission from FSR Inc.

OPERATOR'S SAFETY SUMMARY

The general safety information in this summary is for operating personnel.

Read Instructions. Read and understand all safety and operating instructions before using this equipment. Keep the instructions handy.

Removal of the top cover may expose dangerous voltages. To avoid personal injury, disconnect all power sources before removing the top cover. Do not operate the unit with the cover removed.

Power Source:

This product is intended to operate from the power source detailed in the specification section of this manual. Do not use any other power source or exceed voltage limits.

Grounding the Product:

This product is grounded through the grounding conductor of the power cord. To avoid electrical shock, plug the power cord into a properly wired receptacle before connecting to the product input or output terminals.

Use the Proper Power Cord. Use only the power cord and connector specified for your product. Use only a power cord that is in good condition. Refer cord and connector changes to qualified service personnel.



205 Westwood Ave, Long Branch, NJ 07740
Phone: 866-94 BOARDS (26273) / (732)-222-1511
Fax: (732)-222-7088 | E-mail: sales@touchboards.com

TABLE OF CONTENTS

COMPLIANCE AND SAFETY	2
PROPRIETARY INFORMATION	2
OPERATOR'S SAFETY SUMMARY.....	2
INTRODUCTION	5
FEATURES:.....	5
APPLICATIONS:	5
HV-T3 TABLE BOX INSTALLATION	6
MOUNTING INFORMATION	6
HV-T6 TABLE BOX INSTALLATION	7
HUDDLEVU BRACKET SET INSTALLATION	8
HUDDLEVU BRACKET SET CABLING FOR A FIVE HV-T3 INSTALLATION	13
HUDDLEVU BRACKET SET CABLING FOR AN HV-T6 INSTALLATION	13
MECHANICAL DIMENSIONS	14
HV-T3 TABLE BOX	14
HV-T6 TABLE BOX	15
DV-HSW-41 4X1 SWITCHER	16
HV-CTL CONTROL BOX	16
DV-PC2HD ANALOG PC TO HDMI CONVERTER (OPTION)	17
IT-SACWP SWITCHED WALL PLATE (OPTION).....	18
OPERATION	19
HV-1000 4-PERSON SYSTEM DIAGRAM	20
MULTI-PERSON SYSTEM DIAGRAM	21
HV-CTL HUDDLEVU CONTROLLER	22
DV-HSW-41 HDMI SWITCHER	23
DV-PC2HD ANALOG PC TO HDMI CONVERTER	24
IT-SACWP SWITCHED WALL PLATE	25
RS-232 PROTOCOL	26
HUDDLEVU BEHAVIOR	26
LOCKING/UNLOCKING SWITCH INPUTS	26
POWERING THE MONITOR ON/OFF SERIALLY	27

HUDDLE VU SERIAL COMMANDS	28
HV-CTL REQUEST LIST QUICK REFERENCE.....	28
REQUEST/RESPONSE FORMAT	29
COMMAND REQUEST SYNTAX:.....	29
COMMAND REQUEST COMMENT FIELDS.....	29
ACKNOWLEDGING RECEIPT OF COMMANDS.....	30
ERROR RESPONSE.....	30
CONNECTION REQUEST	31
HELP REQUEST.....	32
LOCK REQUEST.....	34
POWER REQUEST.....	35
RELAY REQUEST.....	36
RESPONSE REQUEST.....	37
SERIAL BIT RATE REQUEST.....	38
STATUS REQUEST.....	39
UNLOCK REQUEST.....	40
VERSION REQUEST	41
VERBOSE REQUEST	42
DV-HSW-41 PINOUTS AND CABLING	43
DB-9 CONNECTION	43
SPECIFICATIONS.....	45
HV-CTL	45
DV-HSW-41.....	45
DV-PC2HD	45
IT-SACWP.....	46
WARRANTY AND RETURN INFO.....	47
WARRANTY POLICY	47
SERVICE AND RETURN AUTHORIZATION	47
CONTACT INFORMATION	47

INTRODUCTION

The HuddleVU system allows for multiple users to share and view their laptops, tablets, and smart phones screens on a main display. Unlike conventional presentation systems, anyone participating can lead the presentation at any given time at the push of a button. LED's indicate which user is currently live and when the system is busy.

HuddleVU creates the ideal environment for people to view and share ideas. The systems include all the necessary video switching equipment, control hardware, display power control and color-coded captive HDMI cables. It is a very simple yet effective system to quickly install and use.

There are two model styles available:

The HV-1000 single table box system employs a single FSR HV-T6 table box that allows 1 to 4 users to plug in and power their laptops or other input devices and simply push a button to display their desktop information on the main display. Any user can switch to their own laptops, tablets, and smartphones at any time simply by pushing their button on the T6 housing.

The individual HV systems accommodate from 3 to 7 users depending on the model. Each user has their own FSR HV-T3 table box to plug into. Each table box contains a pullout HDMI cable and an AC outlet. A single push of a button on each T3 is all that is needed to display the laptop or iPad's desktop information onto the main display. An HV-CTL Controller and up to two DV-HSW-41 HDMI Switchers are included on all systems. The HV-CTL has a power switch, two AC outlets to power the DV-HSW-41 HDMI Switchers and an additional AC outlet to power the main display. The HV-CTL is the main termination point for the system components. When four or less inputs are used the HV-CTL switching can be serially controlled by an external control system.

FEATURES:

- Single button press user selection
- No software or programming required
- Simple installation
- Create attractive workspaces
- Hardware and cables included
- Conversion kits available for VGA and audio input
- Systems with four or less inputs can be controlled by an external control system

APPLICATIONS:

- Classrooms
- Libraries
- Conference Rooms
- Educational Facilities
- Corporate Teleconference Rooms
- Learning Centers
- Training Rooms

MOUNTING INFORMATION

HV-T3 TABLE BOX INSTALLATION

HV-T3 INSTALLATION INSTRUCTIONS

1. DRILL 3.50" DIAMETER HOLE IN TABLE TOP.
2. INSERT HV-T3 ASSEMBLY AND ORIENT AS REQUIRED.
3. INSTALL MOUNTING CLAMPS TO ASSEMBLY AND SECURE TO TABLE BY SCREWING MOUNTING SCREWS TO UNDERSIDE OF TABLE.
4. MAKE ELECTRICAL CONNECTIONS AS REQUIRED. ENSURE HDMI CONNECTOR CAN BE PULLED OUT 3'-0".

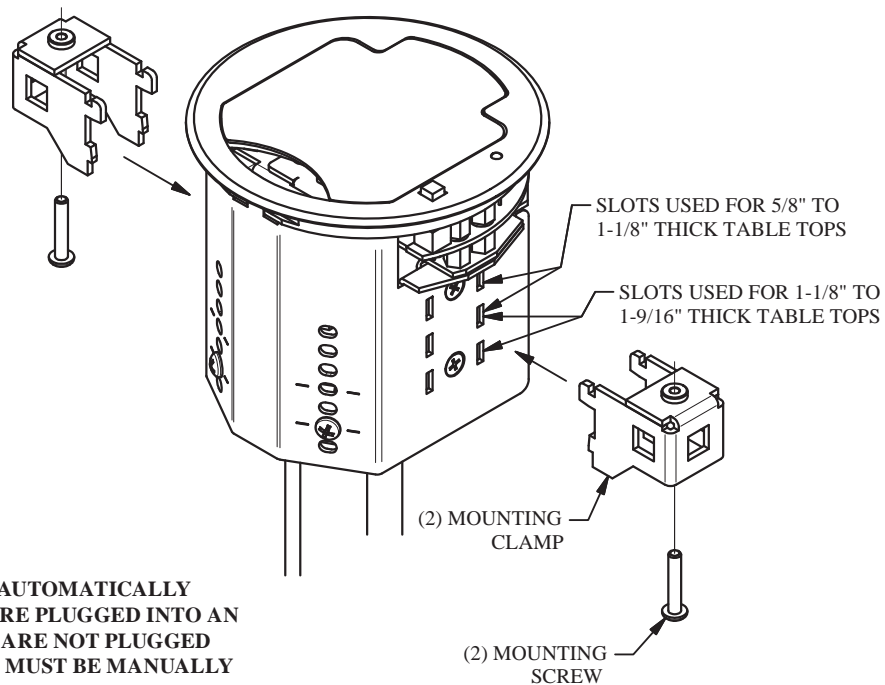
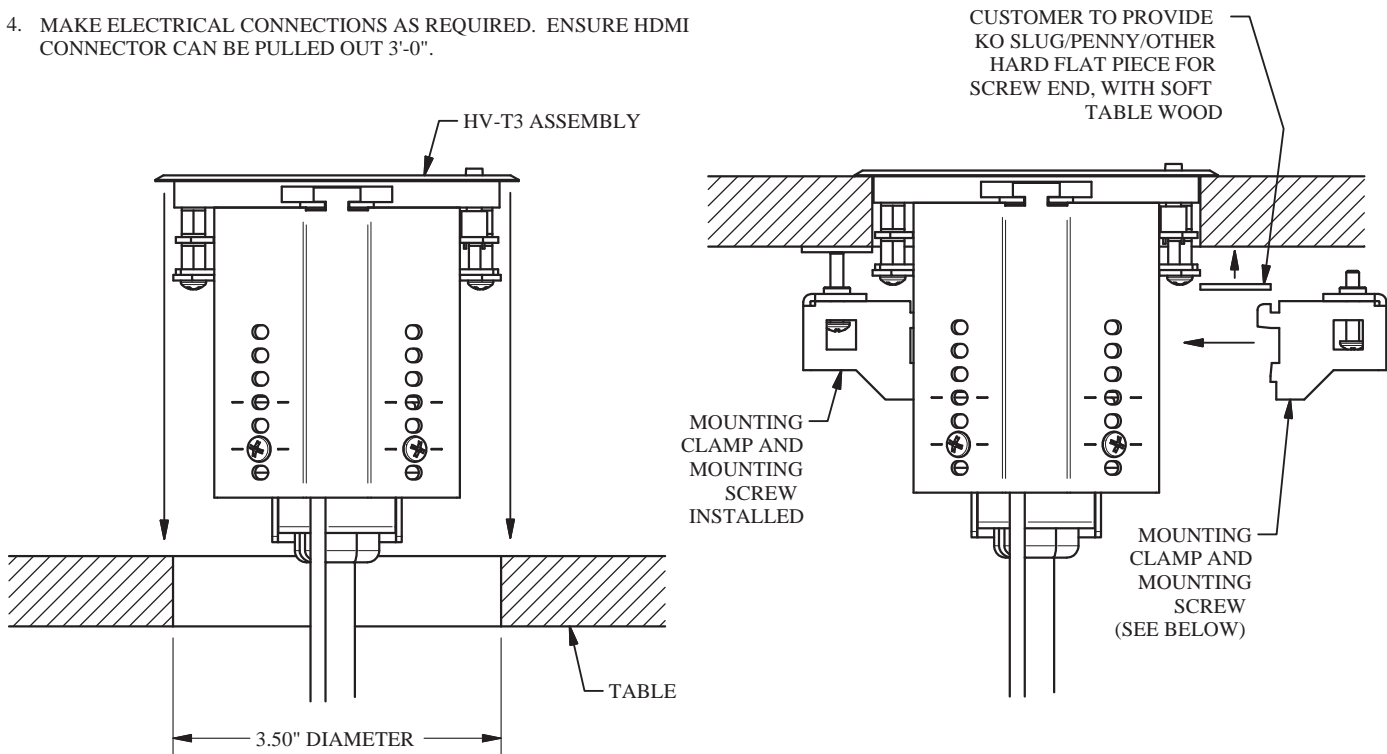

NOTE: TABLE BOXES ARE AUTOMATICALLY GROUNDED WHEN THEY ARE PLUGGED INTO AN AC OUTLET. IF THE UNITS ARE NOT PLUGGED INTO AN AC OUTLET THEY MUST BE MANUALLY GROUNDED.

HV-T6 TABLE BOX INSTALLATION

HV-T6 INSTALLATION INSTRUCTIONS

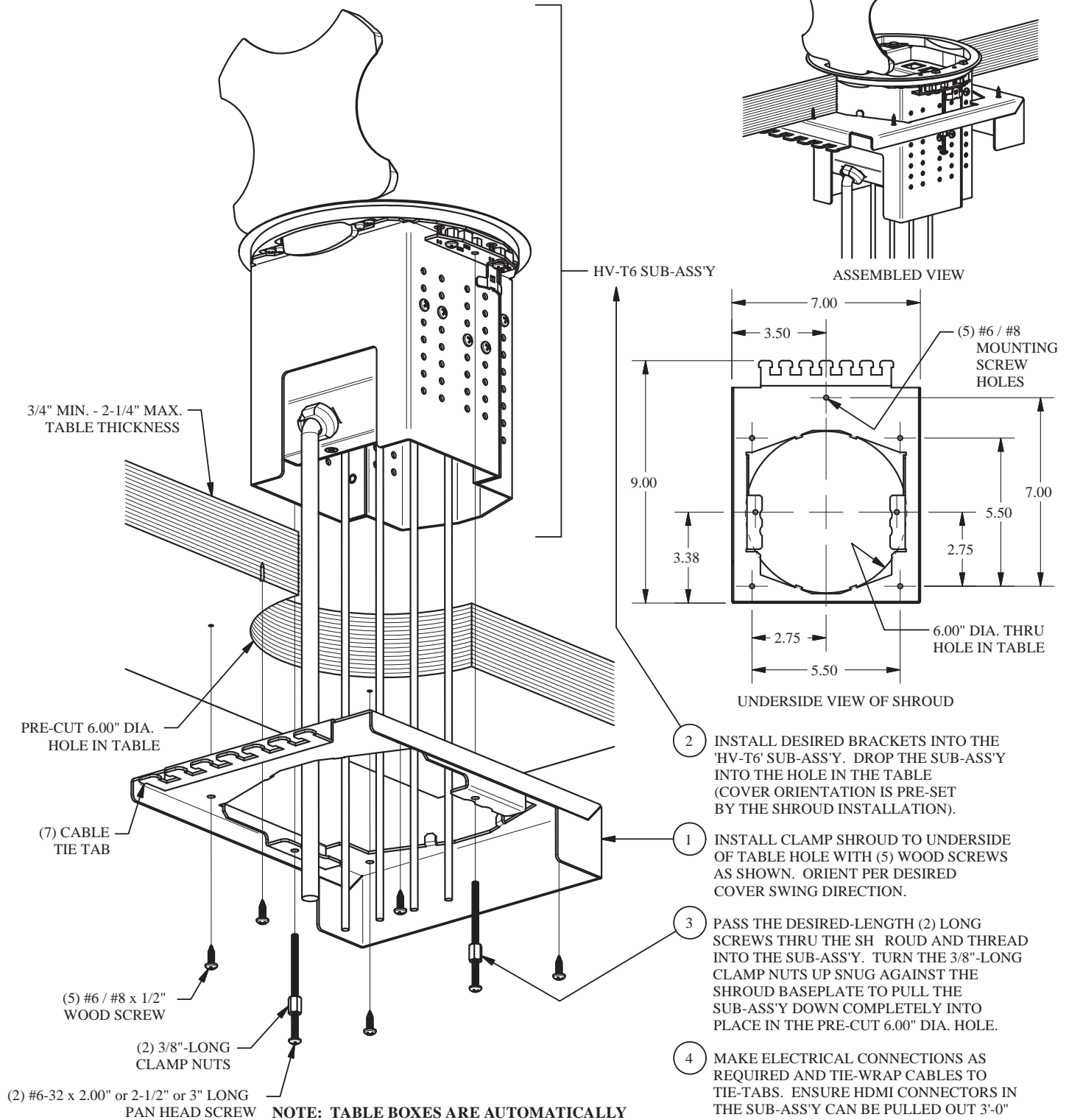

NOTE: TABLE BOXES ARE AUTOMATICALLY GROUNDED WHEN THEY ARE PLUGGED INTO AN AC OUTLET. IF THE UNITS ARE NOT PLUGGED INTO AN AC OUTLET THEY MUST BE MANUALLY GROUNDED.

- 1 INSTALL CLAMP SHROUD TO UNDERSIDE OF TABLE HOLE WITH (5) WOOD SCREWS AS SHOWN. ORIENT PER DESIRED COVER SWING DIRECTION.
- 2 INSTALL DESIRED BRACKETS INTO THE 'HV-T6' SUB-ASS'Y. DROP THE SUB-ASS'Y INTO THE HOLE IN THE TABLE (COVER ORIENTATION IS PRE-SET BY THE SHROUD INSTALLATION).
- 3 PASS THE DESIRED-LENGTH (2) LONG SCREWS THRU THE SHROUD AND THREAD INTO THE SUB-ASS'Y. TURN THE 3/8"-LONG CLAMP NUTS UP SNUG AGAINST THE SHROUD BASEPLATE TO PULL THE SUB-ASS'Y DOWN COMPLETELY INTO PLACE IN THE PRE-CUT 6.00" DIA. HOLE.
- 4 MAKE ELECTRICAL CONNECTIONS AS REQUIRED AND TIE-WRAP CABLES TO TIE-TABS. ENSURE HDMI CONNECTORS IN THE SUB-ASS'Y CAN BE PULLED OUT 3'-0" PRIOR TO SECURING CABLES TO TIE TABS.

HUDDLEVU BRACKET SET INSTALLATION

1. LOOSEN BASE PLATE SCREWS AND SEPARATE BASE PLATE FROM TABLE BRACKET. DETERMINE EQUIPMENT LOCATION AND MOUNT TABLE BRACKET TO UNDERSIDE OF TABLE WITH SUPPLIED #8 WOOD SCREWS OR CUSTOMER SUPPLIED #8 COUNTER-SUNK HARDWARE.

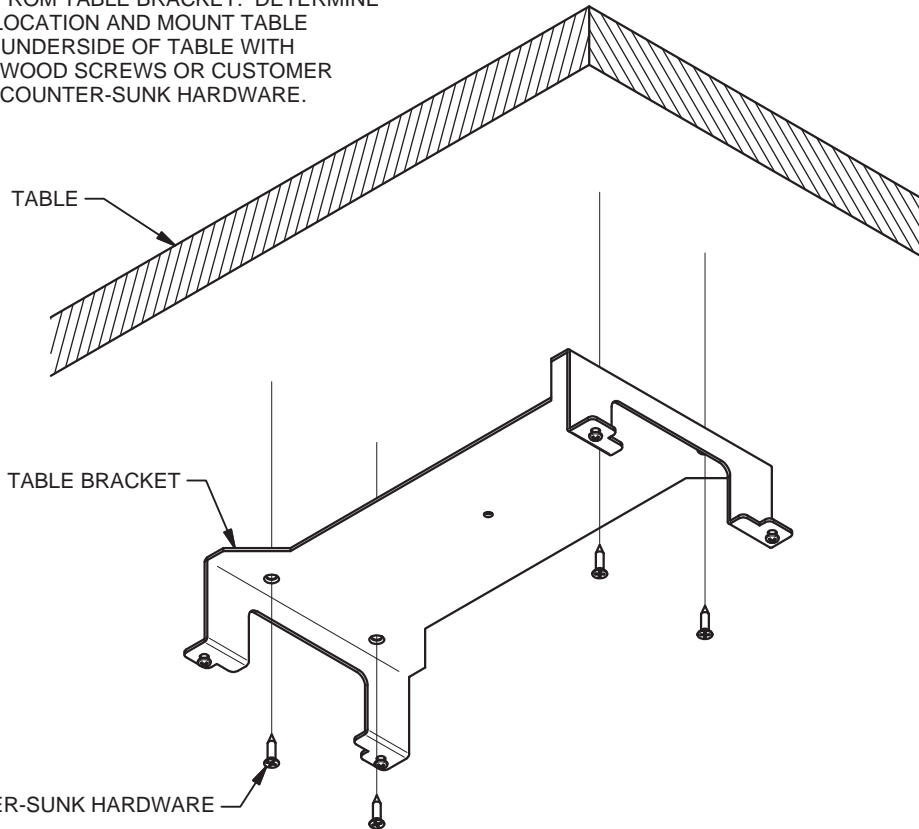

2. REMOVE AND DISCARD EXISTING SCREWS FROM HV-CTL UNIT.

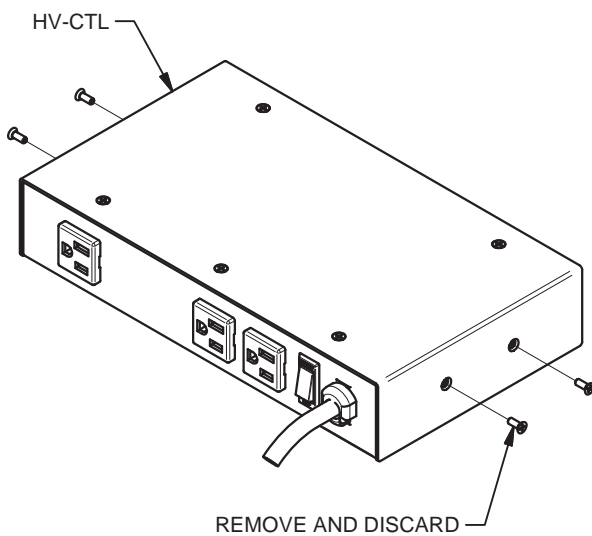

3. INSTALL HV-CTL TO BASE PLATE WITH SUPPLIED #6 HARDWARE.

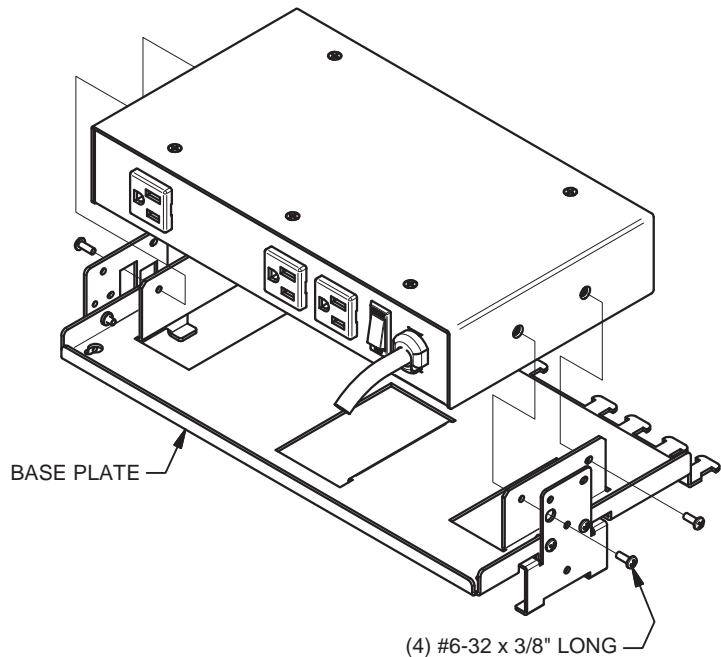

4A. INSTALLING ONE DV-HSW-41 UNIT:

- a. INSTALL DV-HSW-41 TO BASE PLATE WITH SUPPLIED M3 HARDWARE.

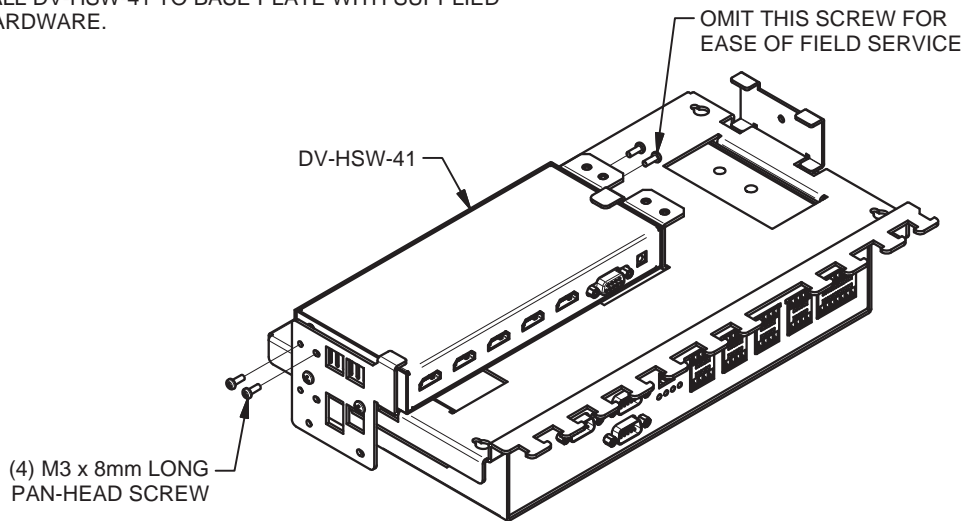

4B. INSTALLING TWO DV-HSW-41 UNITS:

- a. REMOVE DV-HSW-41 SIDE BRACKET AND REINSTALL TO NEW POSITION ONTO BASE PLATE.

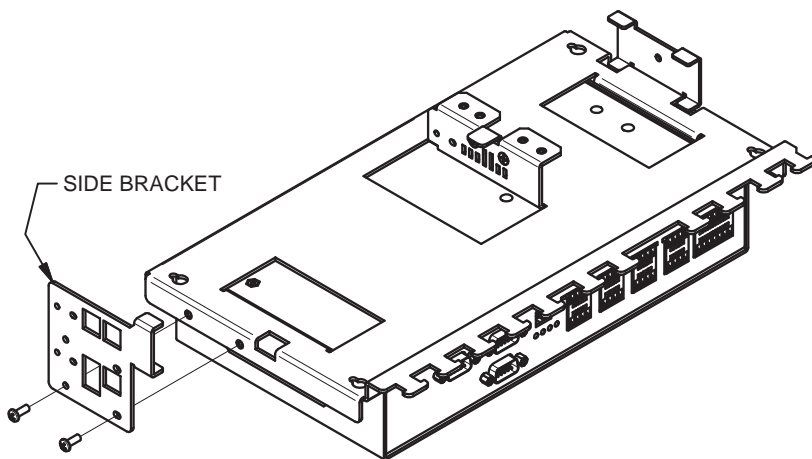

- b. INSTALL DV-HSW-41 MOUNTING/SUPPORT BRACKET TO BASE PLATE WITH SUPPLIED #6 HARDWARE.

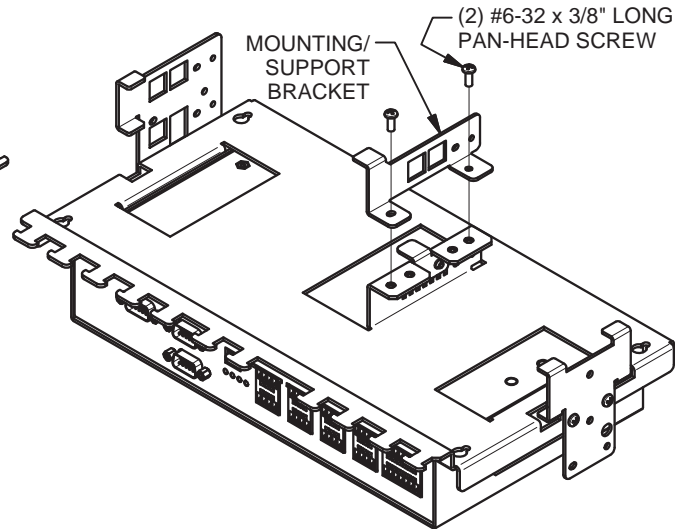

- c. INSTALL DV-HSW-41 TO BASE PLATE WITH SUPPLIED M3 HARDWARE.

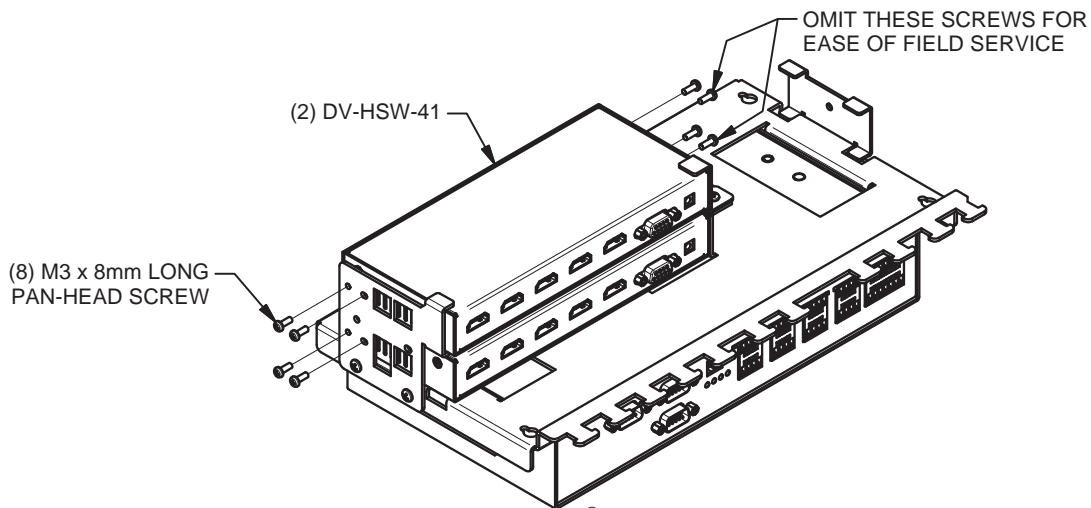

5A. INSTALLING ONE DV-PC2HD UNIT:

- a. INSTALL MOUNTING BRACKET TO DV-PC2HD WITH #6 HARDWARE (MOUNTING BRACKET AND #6 HARDWARE SUPPLIED WITH DV-PC2HD).

- b. INSTALL DV-PC2HD WITH ATTACHED MOUNTING BRACKET TO BASE PLATE WITH SUPPLIED #6 HARDWARE AND #6 HARDWARE SUPPLIED WITH DV-PC2HD.

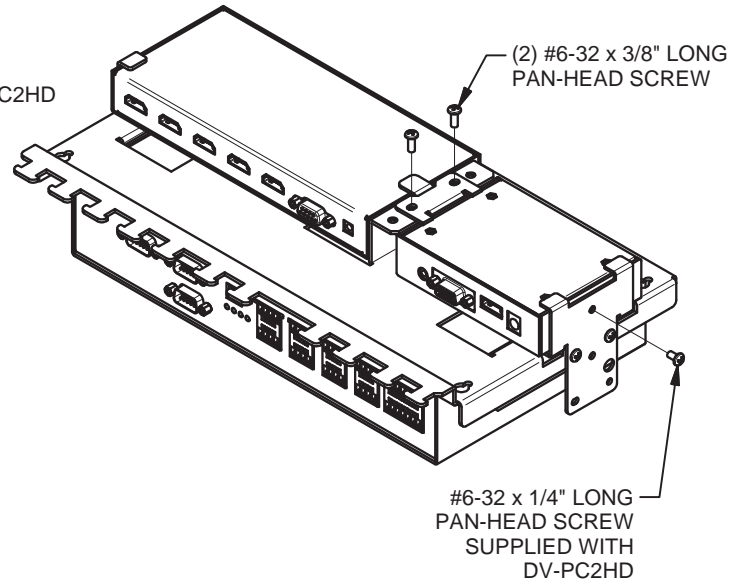
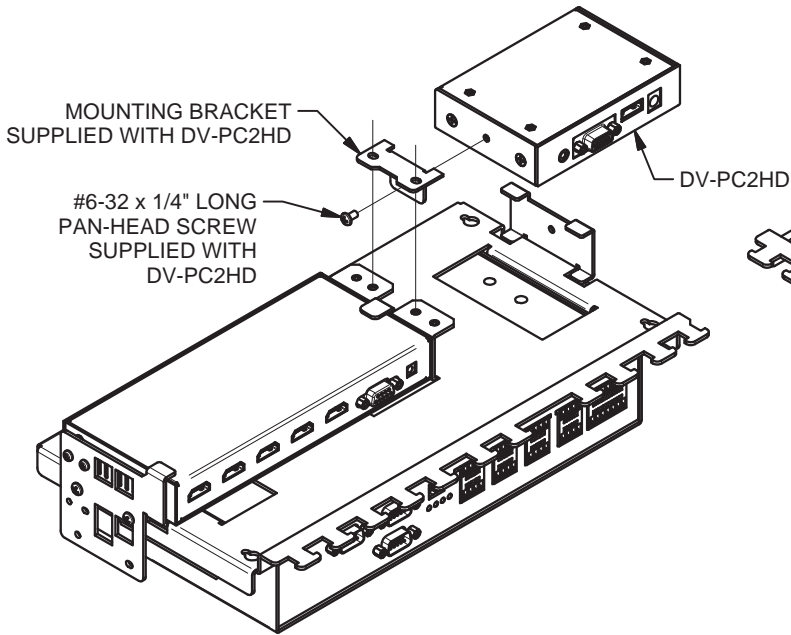

5B. INSTALLING TWO DV-PC2HD UNITS:

- a. REMOVE DV-PC2HD SIDE BRACKET. INSTALL MOUNTING BRACKET TO DV-PC2HD WITH #6 HARDWARE (MOUNTING BRACKET AND #6 HARDWARE SUPPLIED WITH DV-PC2HD). INSTALL DV-PC2HD WITH ATTACHED MOUNTING BRACKET TO BASE PLATE WITH SUPPLIED #6 HARDWARE.

- b. REINSTALL SIDE BRACKET TO BASE PLATE AND SECURE DV-PC2HD WITH #6 HARDWARE SUPPLIED WITH DV-PC2HD.

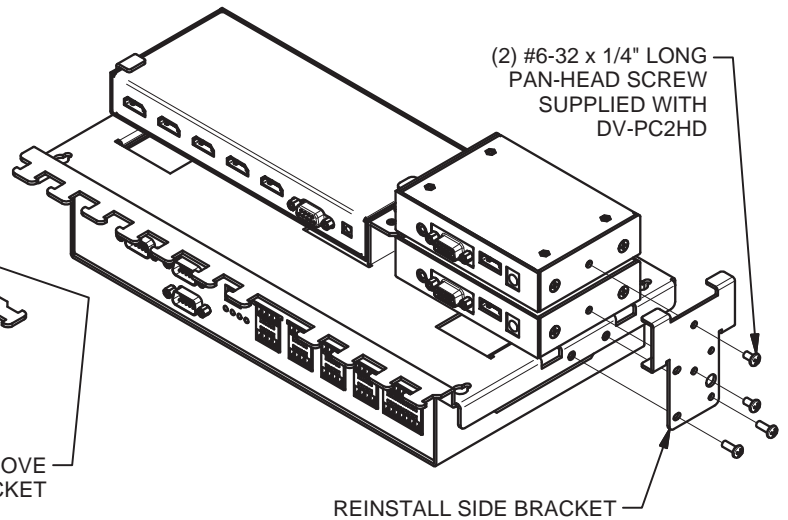
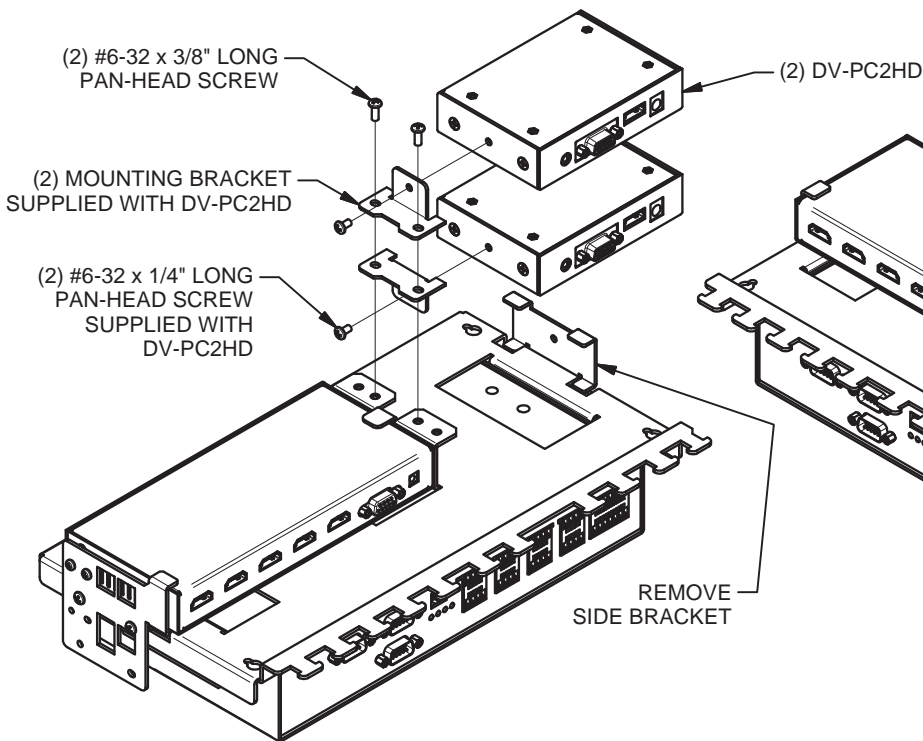

6. REINSTALL BASE PLATE ASSEMBLY TO TABLE BRACKET AND MAKE ELECTRICAL CONNECTIONS AS REQUIRED. TIE-WRAP CABLES TO TIE-TABS AS REQUIRED.

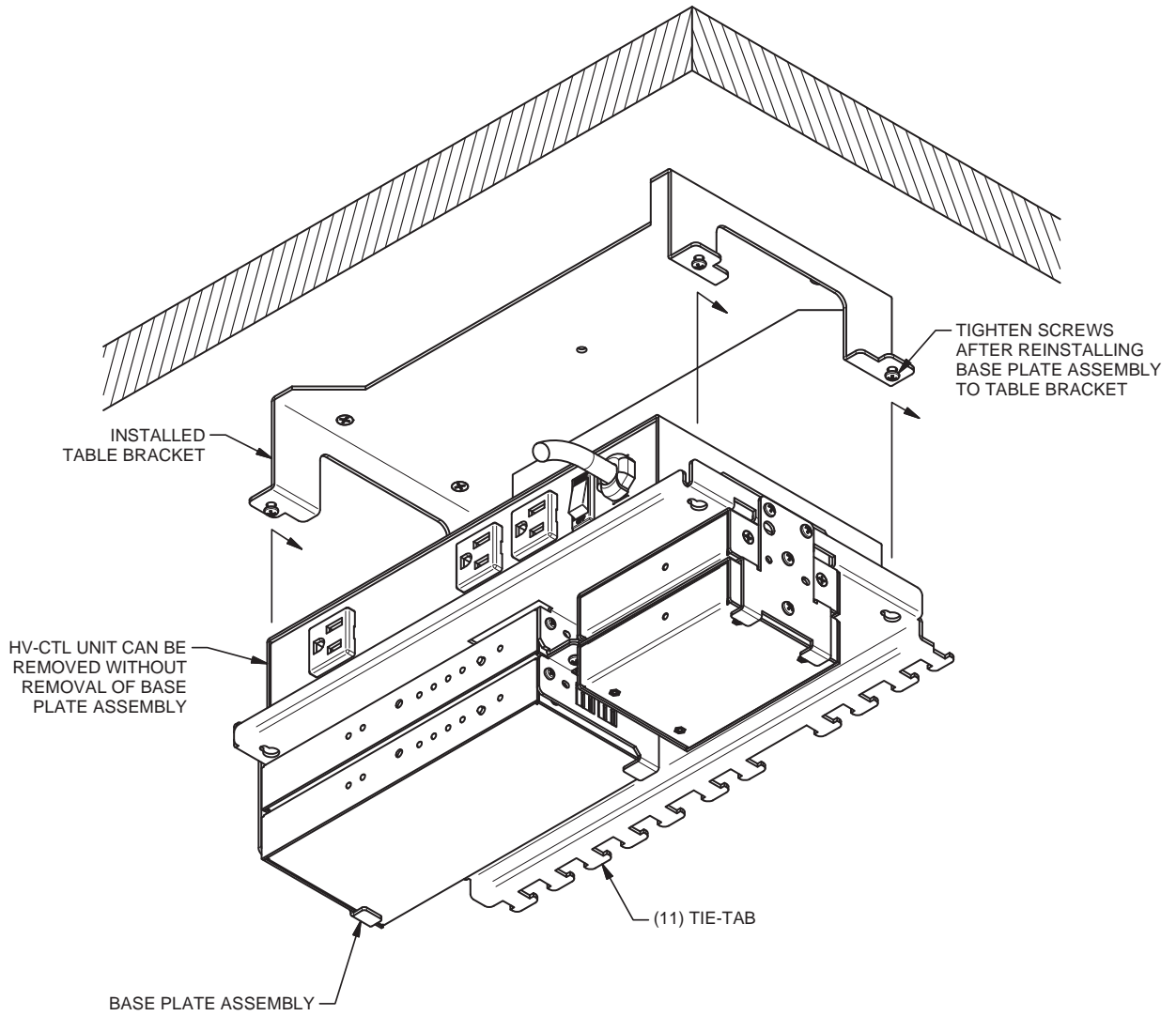

HUDDLEVU BRACKET SET CABLING FOR A FIVE HV-T3 INSTALLATION



USE THE TABS PROVIDED TO SECURE THE CABLES USING TIE WRAPS THROUGHOUT

HUDDLEVU BRACKET SET CABLING FOR AN HV-T6 INSTALLATION

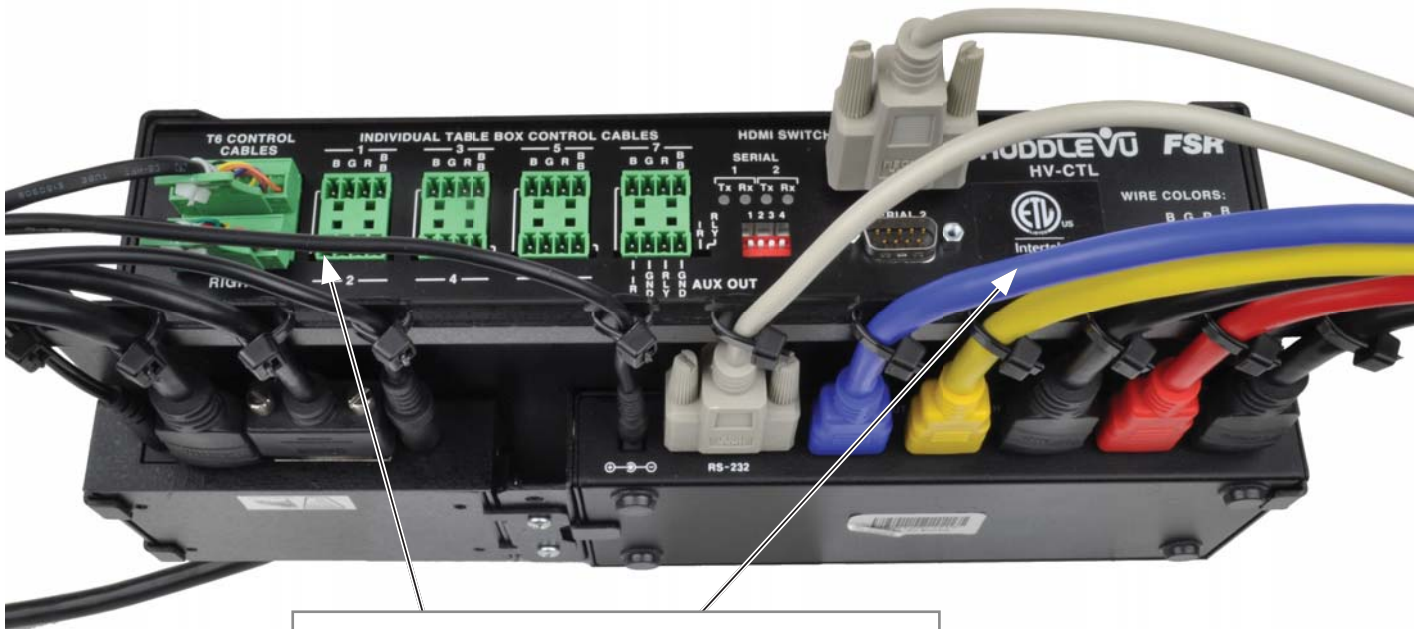

USE THE TABS PROVIDED TO SECURE THE CABLES USING TIE WRAPS THROUGHOUT

MECHANICAL DIMENSIONS

HV-T3 TABLE BOX

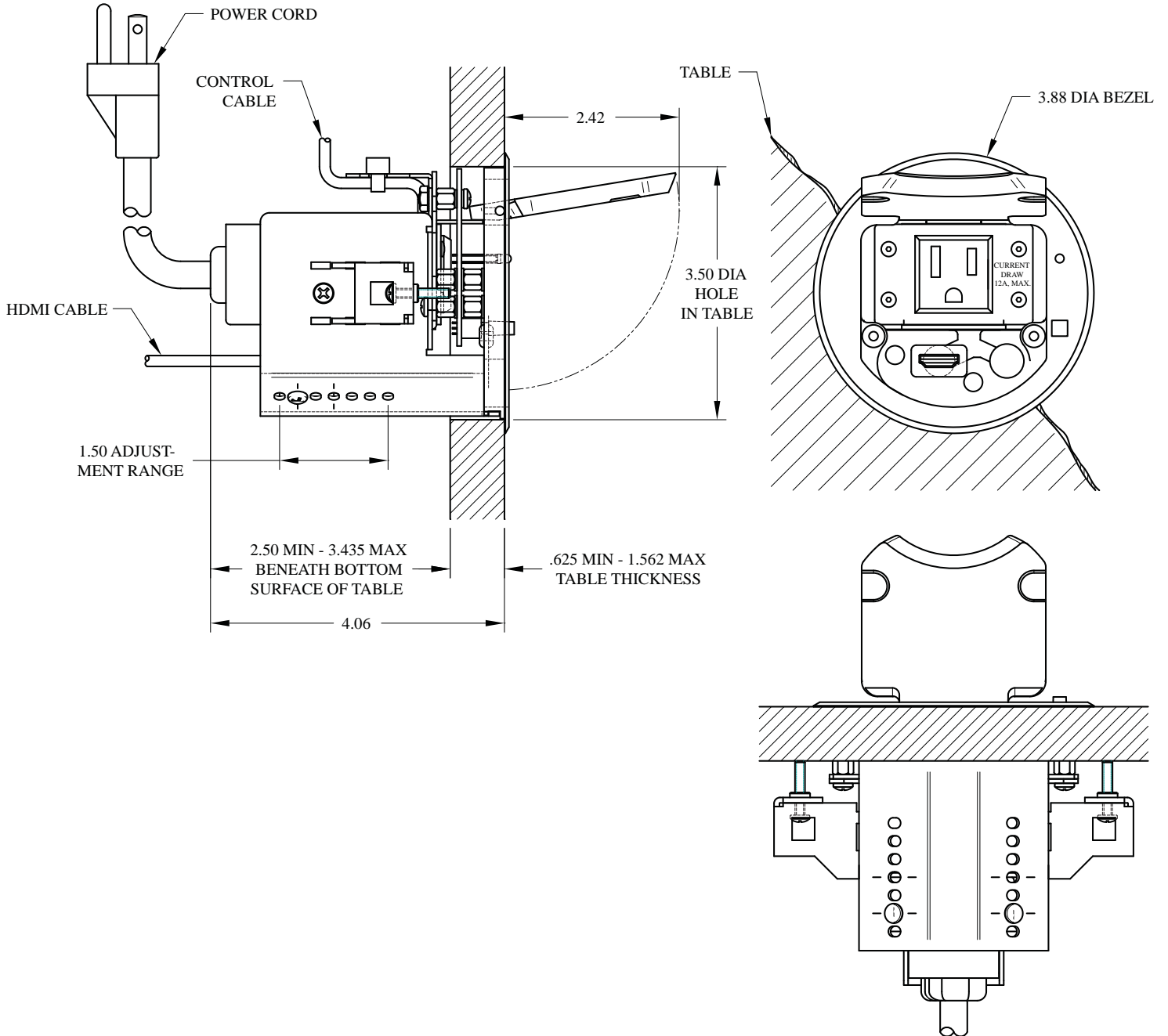

HV-T6 TABLE BOX

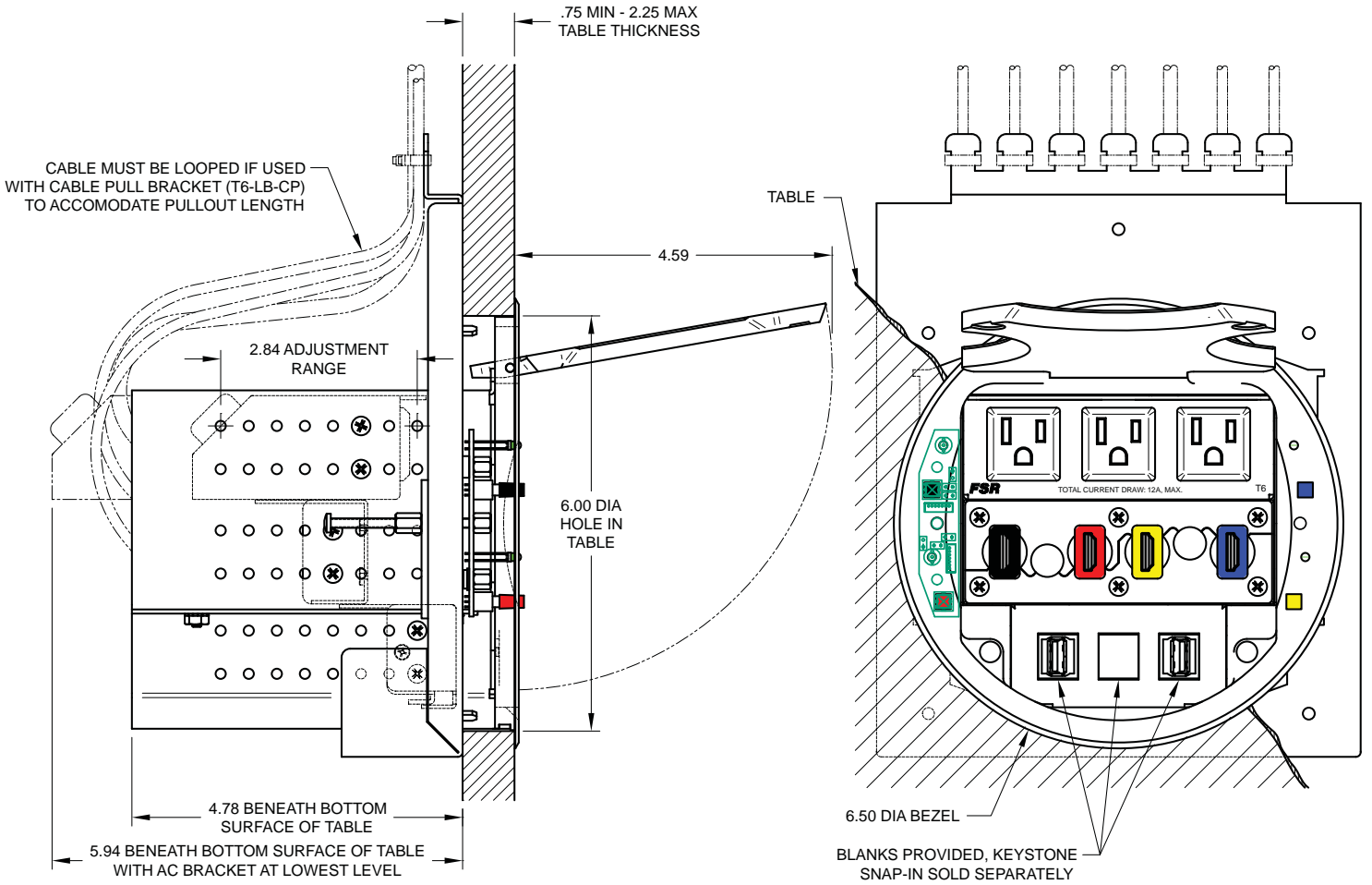

DV-HSW-41 4X1 SWITCHER

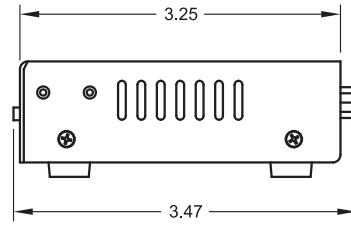
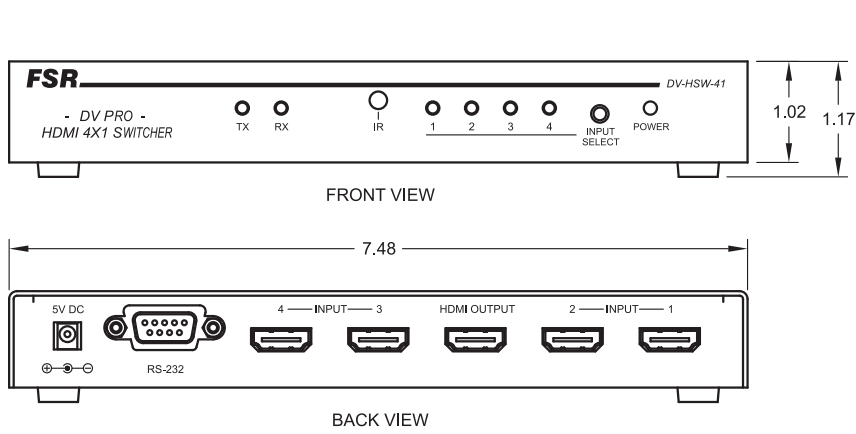

HV-CTL CONTROL BOX

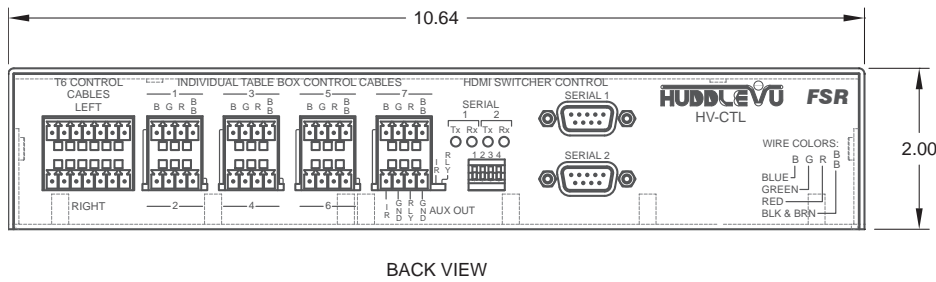
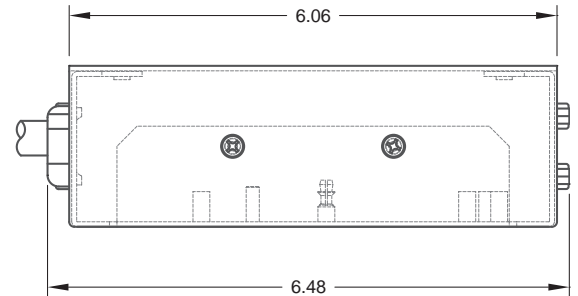
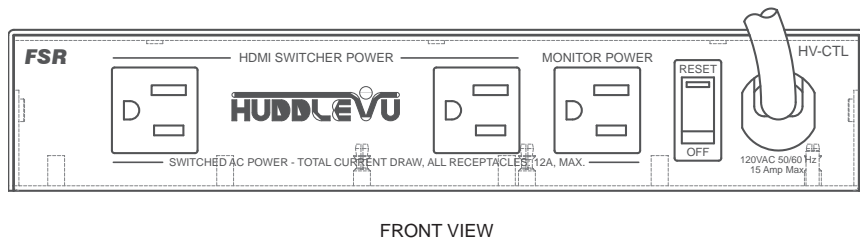

DV-PC2HD ANALOG PC TO HDMI CONVERTER (OPTION)

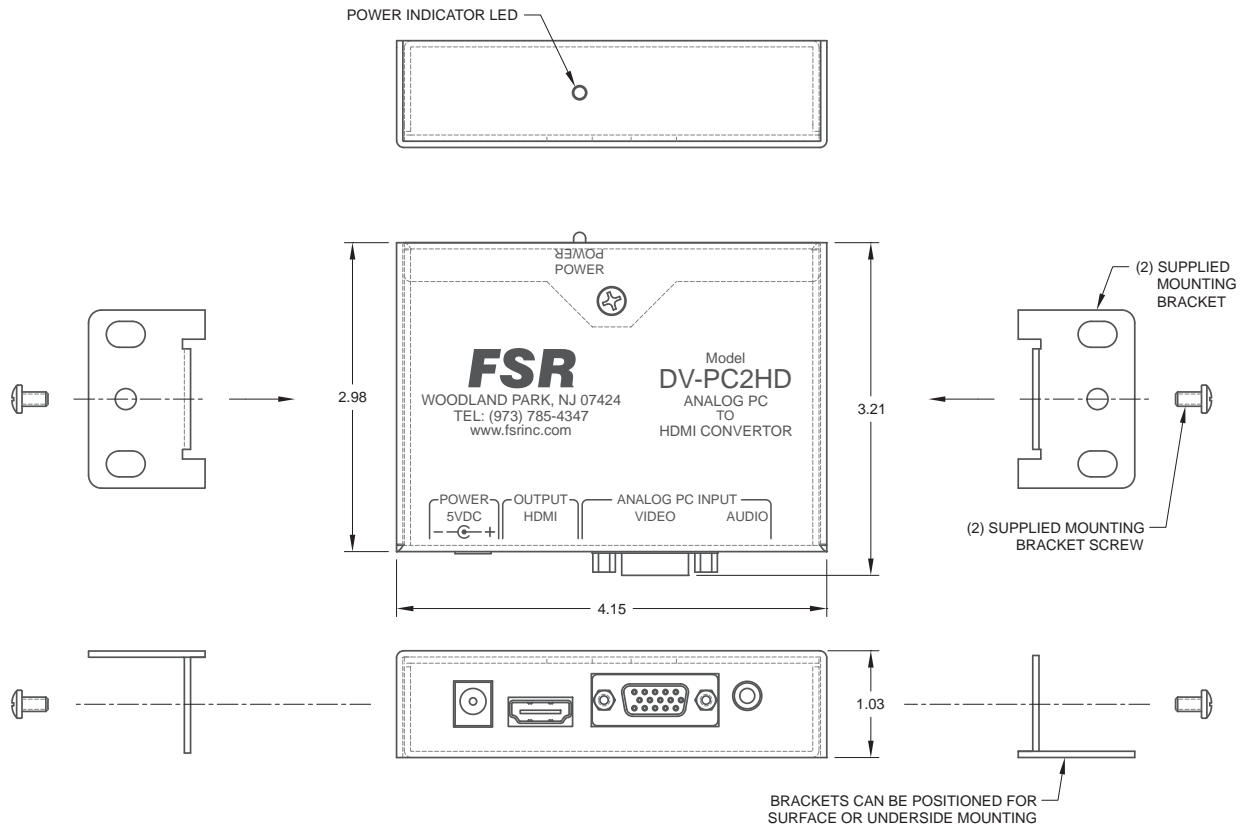

IT-SACWP SWITCHED WALL PLATE (OPTION)

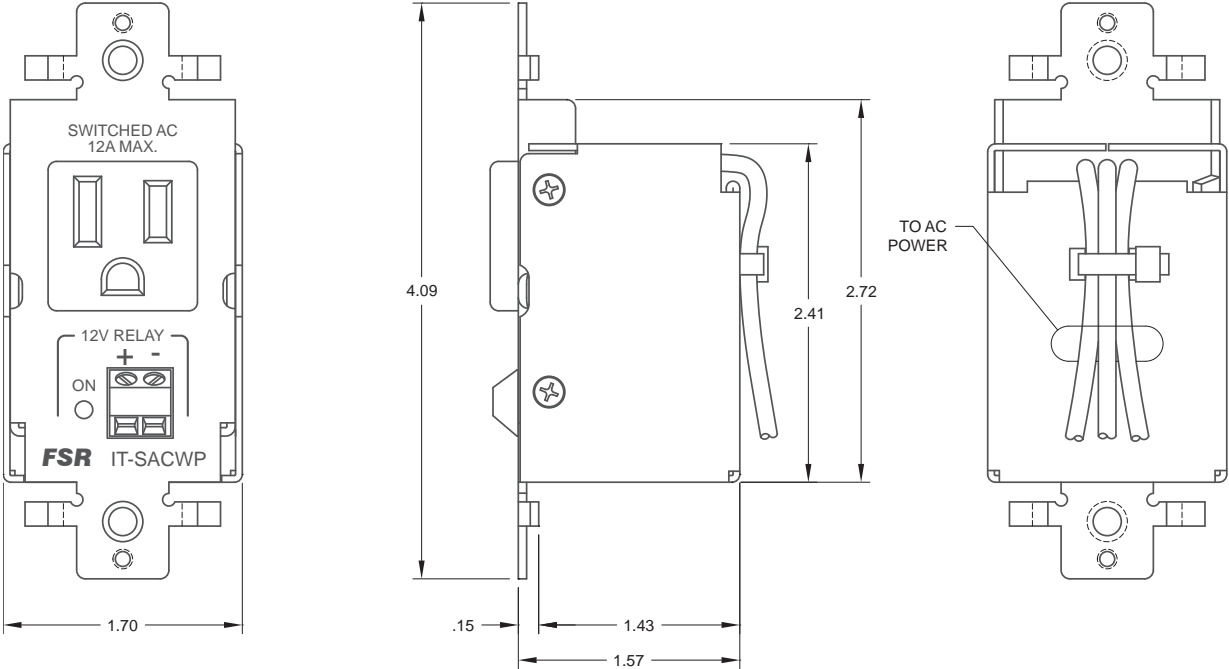

OPERATION

Power up the system via the power switch located on the AC side of the HV-CTL Control Unit. The Green LEDs on the Table Boxes (referred to as "TB" from this point on) will flash for approximately 3 seconds and then turn off. The system is now in the IDLE state and is ready to accept switch inputs/presses from the table boxes. Note that the monitor and HDMI switchers are not yet turned on and no switch inputs are honored while the LEDs are flashing.

From the IDLE state, press any one of the available switches on any of the TB's to activate the system. The monitor and HDMI switcher(s) will be immediately powered ON and all TB Green LEDs will flash for a short time to indicate the system is powering up. Upon release of the selected switch, the selected switch's corresponding Green LED will flash at a fast rate for a short duration before turning steady green (to indicate that particular selection was recognized). All other TB LEDs remain Red and the HDMI source from that input is selected and is routed to the monitor. While the green LEDs of the selected input switch are flashing, no other switch selections are honored. The unit is now in the ON state and is ready to accept additional switch presses allowing the users to switch their source's program material to the monitor. (There is no unconnected state for the HDMI switchers.)

Subsequent switch presses on any of the TB switches for less than 3 seconds will select that TB's source and display it on the monitor. The Green LED will flash at a fast rate for a short duration to indicate the selection was recognized, all other TB LEDs will go Red upon release of the switch. While the green LEDs of the selected input switch are flashing, no other switch selections are honored. The unit remains in the ON state.

To return the system to the IDLE state: Press and hold any switch for a duration of greater than 3 seconds. The monitor and HDMI switcher(s) will be switched OFF at the 3 second mark, all TB Red LEDs will flash for a short time (approximately 3 seconds) and then all TB LEDs will be turned OFF indicating a return to the IDLE state.

HV-1000 4-Person Collaboration System

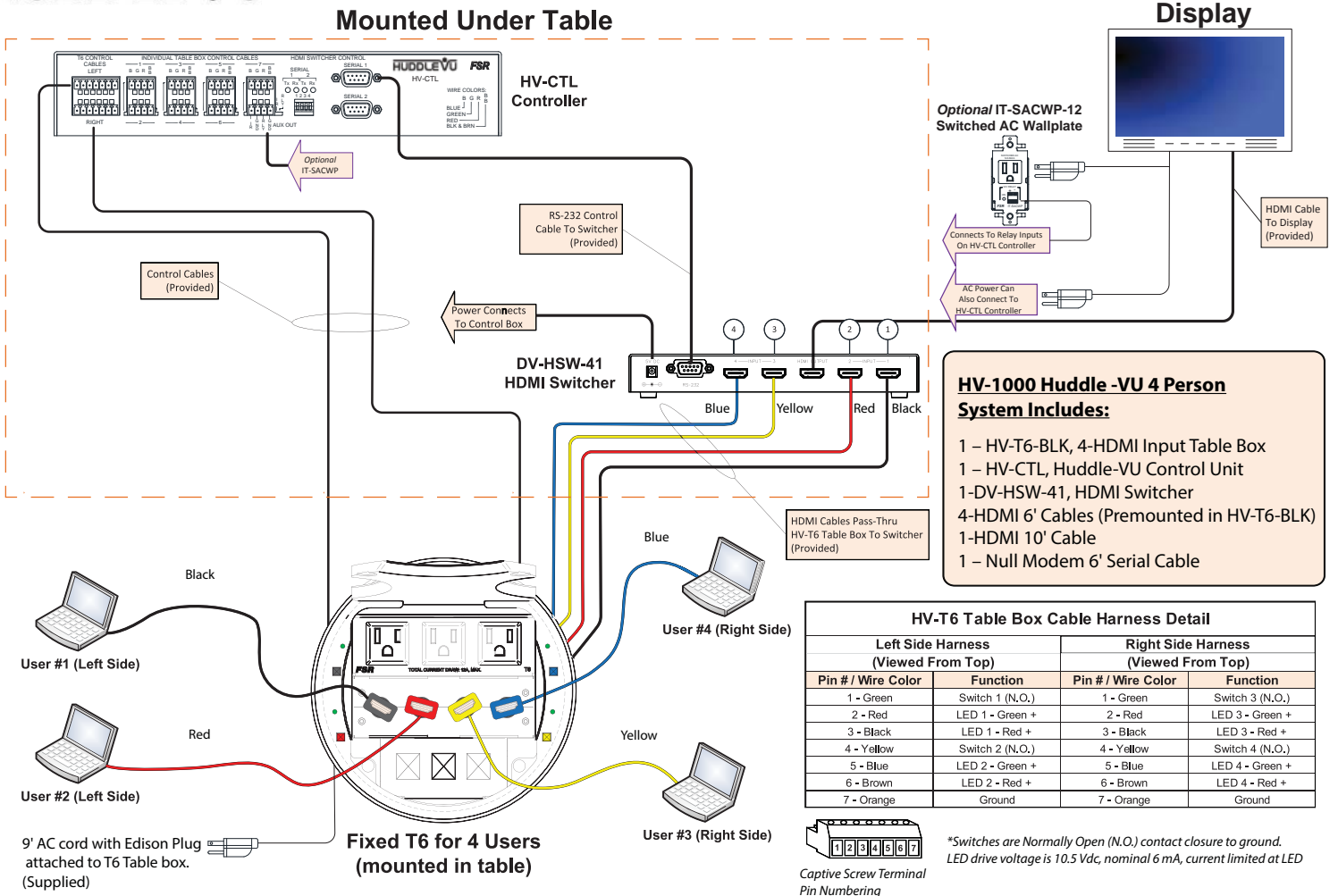

Multi-Person HuddleVU System Includes:

- 1-HV-CTL HuddleVU Control Unit
- 1-Null Modem 6' Serial Cable
- 1-HDMI 10' Cable (To Display)
- 1-DV-HSW-41 HDMI Switcher (Up to 4 Users)
(2nd DV-HSW-41 & Null Modem 6' Serial Cable included with 5+ User Packages)
- 1-HV-T3-BLK Table Box (Per User)
- 1-6' HDMI & Control Cables (Included in HV-T3-BLK)

Huddle -VU Multi-Person Systems:

- HV-300 Huddle-VU (3 Users)
- HV-400 Huddle-VU (4 Users)
- HV-500 Huddle-VU (5 Users)
- HV-600 Huddle-VU (6 Users)
- HV-700 Huddle-VU (7 Users)

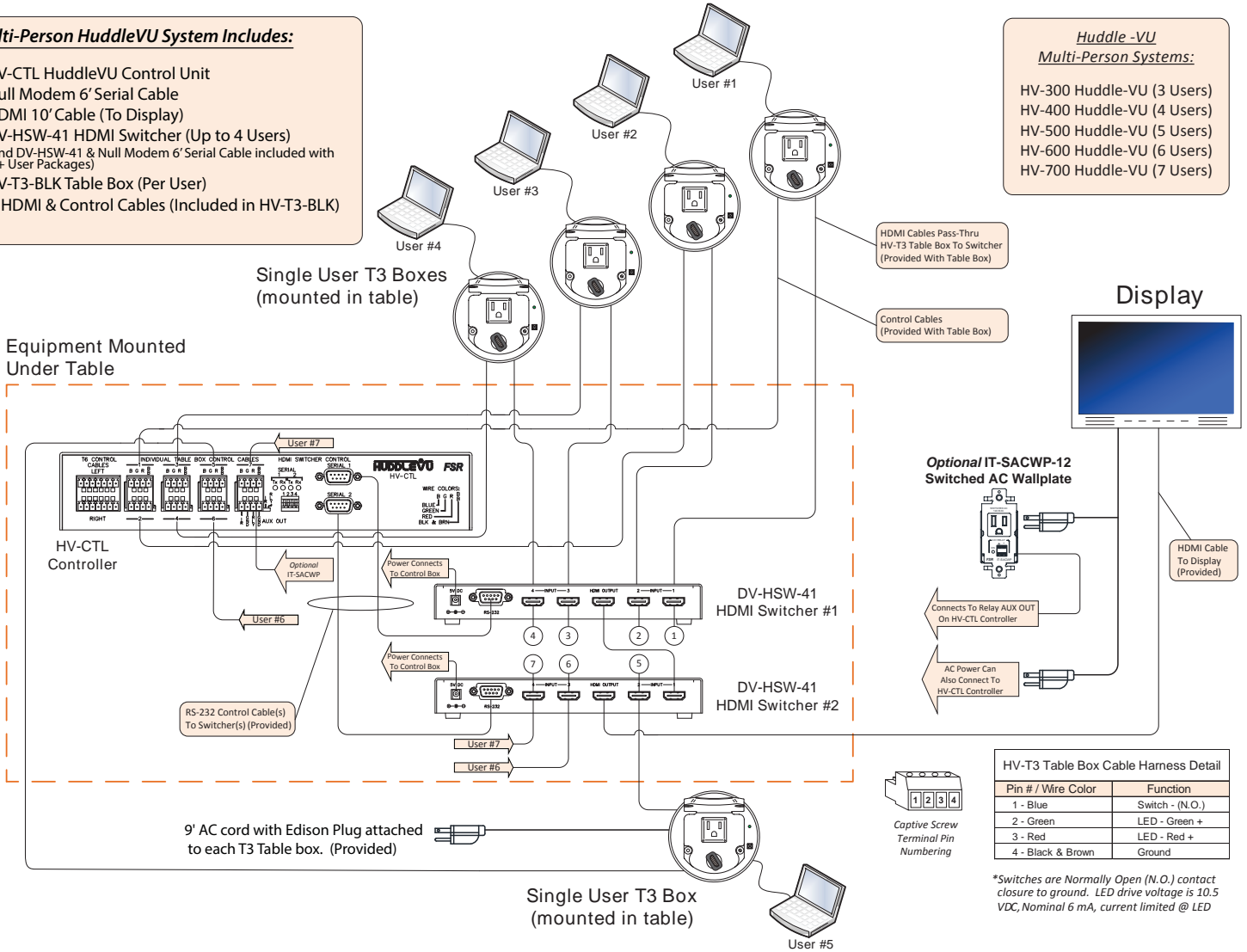

HV-CTL HUDDLEVU CONTROLLER



1. HDMI switcher power outlet
2. HDMI switcher power outlet
3. Monitor power outlet
4. Power switch and circuit breaker
5. Power cord
6. T6 Left control ports
7. T6 Right control ports
8. T3 control ports #1 with status indicator
9. T3 control ports #2 with status indicator
10. T3 control ports #3 with status indicator
11. T3 control ports #4 with status indicator
12. T3 control ports #5 with status indicator
13. T3 control ports #6 with status indicator
14. T3 control ports #7 with status indicator
15. 12Vdc relay drive output, IR output (for future use) and status indicator
16. RS-232 data indicators
17. DIP switch (for future use)
18. HDMI switcher RS-232 port, Male DB-9
19. HDMI switcher RS-232 port, Male DB-9

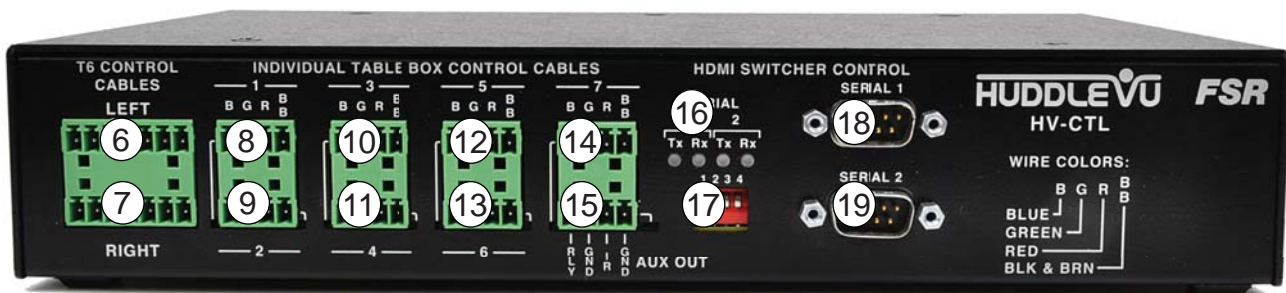

DV-HSW-41 HDMI SWITCHER



- | | |
|-------------------------------------|------------------|
| 1. Serial transmit and receive LEDs | 7. RS-232 port |
| 2. IR sensor | 8. HDMI input 4 |
| 3. HDMI input status LEDs | 9. HDMI input 3 |
| 4. HDMI input selector switch | 10. HDMI output |
| 5. Power LED | 11. HDMI input 2 |
| 6. 5VDC power input | 12. HDMI input 1 |



205 Westwood Ave, Long Branch, NJ 07740
Phone: 866-94 BOARDS (26273) / (732)-222-1511
Fax: (732)-222-7088 | E-mail: sales@touchboards.com

DV-PC2HD ANALOG PC TO HDMI CONVERTER



- 1. Power LED
- 2. 5VDC power input
- 3. HDMI output
- 4. HD-15 VGA input
- 5. Stereo 3.5mm audio input

The DV-PC2HD converts a variety of VGA signals and stereo audio to HDMI. The signal resolution at the HDMI output is dependent on the VGA input resolution as shown in the table below. The unit is easy to install and operate and does not require any adjustments.

Video Resolutions supported by the DV-PC2HD @ 60 Hz		
1920 x 1080	1680 x 1050	1600 x 1200
1600 x 1024	1600 x 900	1440 x 900
1360 x 1024	1366 x 768	1360 x 768
1280 x 1024	1280 x 960	1280 x 900
1280 x 800	1280 x 768	1280 x 720
1152 x 864	1024 x 768	800 x 600
	640 x 480	

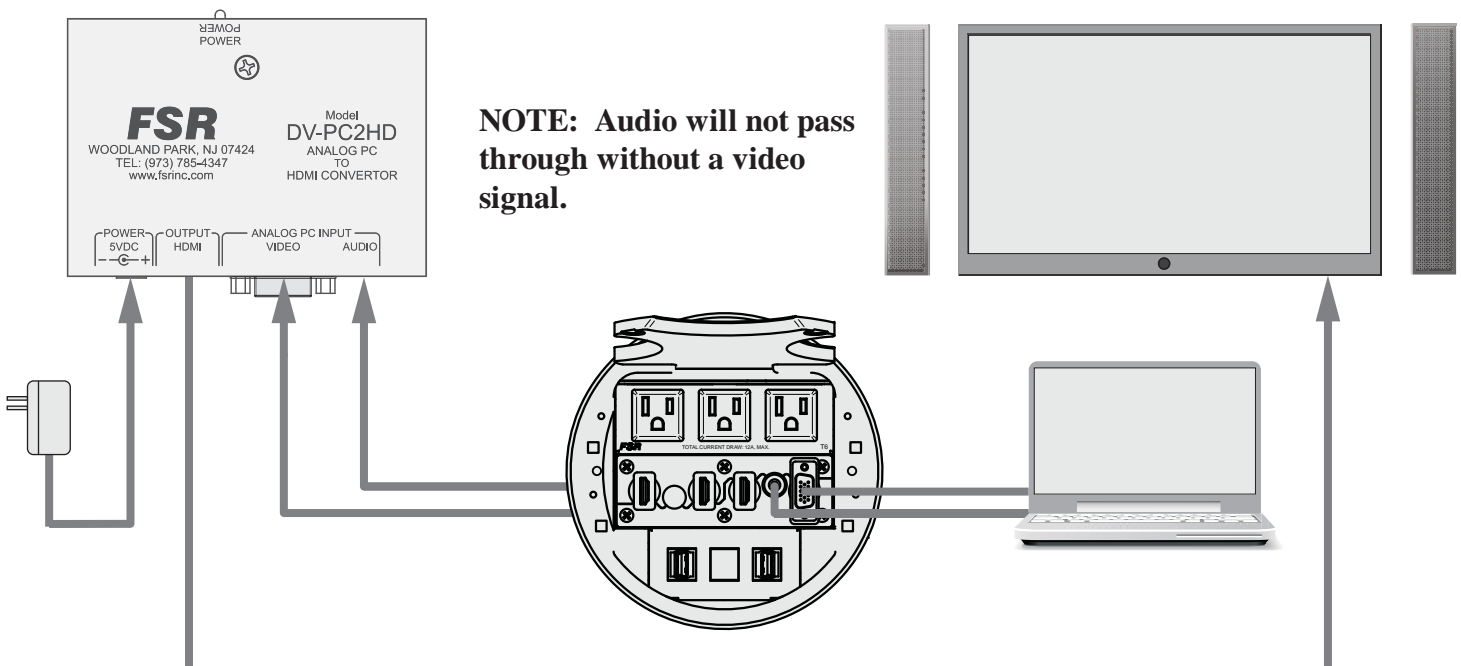

IT-SACWP SWITCHED WALL PLATE



The IT-SACWP wall plate provides convenient, remotely switched AC to power projectors, displays and other AC powered devices via a low voltage hard wired control input. A great accessory to use with the HuddleVU system.

The single gang, Decora style, 12 amp rated, switched AC outlet wires directly to a 15 amp branch circuit via the input harness at the back of the unit. Connections to the branch circuit are made using the included wire nuts.

The switching technology is relay based for reliable operation and minimal heat dissipation. Control is accomplished via the fixed 2 position screw terminal connector. A green LED is provided for visual indication of the relay state. The unit requires a 12VDC @ 88mA input to operate the relay.

The unit includes 14 AWG solid wire 6" free length, (L, N, G) for AC input, wire nuts, white wall plate with black AC outlet, LED relay state indicator and screw terminals for quick and easy control input wiring.

TYPICAL APPLICATION OF POWER TO A VIDEO DISPLAY CONTROLLED BY AN IT-SACWP SWITCHED AC WALLPLATE

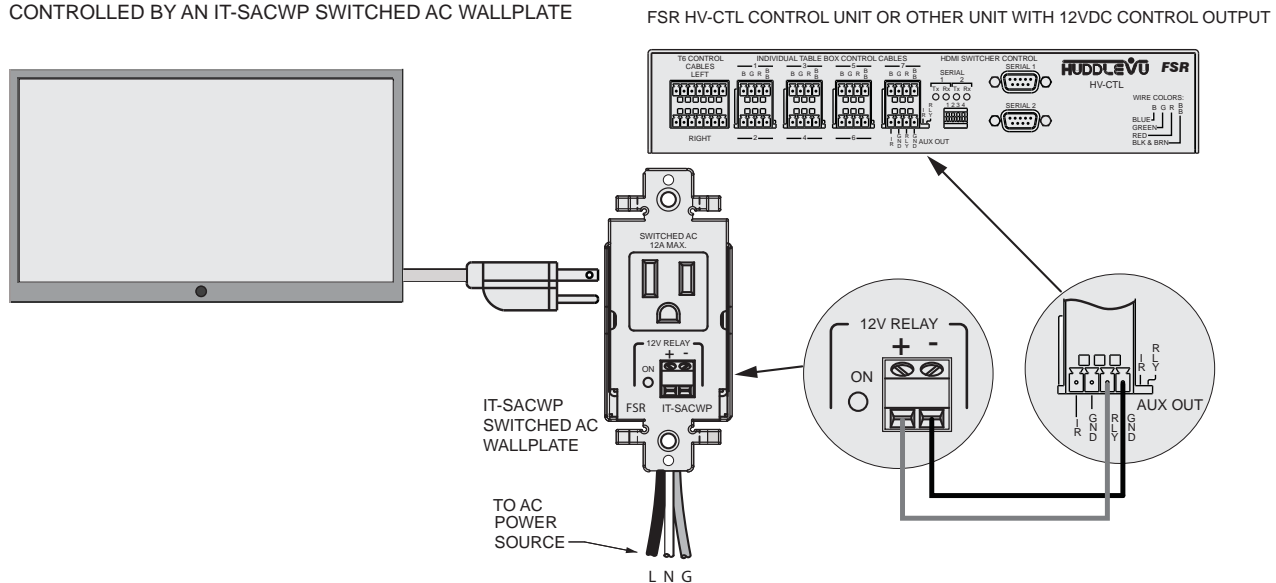

RS-232 PROTOCOL

HUDDLEVU BEHAVIOR

Power up the system via the power switch located on the AC side of the HV-CTL Control Unit. The Green LEDs on the Table Boxes (referred to as "TB" from this point on) will flash for approximately 3 seconds and then turn off. The system is now in the IDLE state and is ready to accept switch inputs/presses from the table boxes. Note that the monitor and HDMI switchers are not yet turned on and no switch inputs are honored while the LEDs are flashing.

From the IDLE state, press any one of the available switches on any of the TB's to activate the system. The monitor and HDMI Switcher(s) will be immediately powered ON and all TB Green LEDs will flash for a short time to indicate the system is powering up. Upon release of the selected switch, the selected switch's corresponding Green LED will flash at a fast rate for a short duration before turning steady green (to indicate that particular selection was recognized). All other TB LEDs remain Red and the HDMI source from that input is selected and is routed to the monitor. While the green LEDs of the selected input switch are flashing, no other switch selections are honored. The unit is now in the ON state and is ready to accept additional switch presses allowing the users to switch their source's program material to the monitor. (There is no unconnected state for the HDMI switchers.)

Subsequent switch presses on any of the TB switches for less than 3 seconds will select that TB's source and display it on the monitor. The Green LED will flash at a fast rate for a short duration to indicate the selection was recognized, all other TB LEDs will go Red upon release of the switch. While the green LEDs of the selected input switch are flashing, no other switch selections are honored. The unit remains in the ON state.

To return the system to the IDLE state: Press and hold any switch for a duration of greater than 3 seconds. The monitor and HDMI switcher(s) will be switched OFF at the 3 second mark, all TB Red LEDs will flash Red for a short time (approximately 3 seconds) and then all TB LEDs will be turned off indicating a return to the IDLE state.

LOCKING/UNLOCKING SWITCH INPUTS

The user may wish to lock a specified switch input(s) from recognition. This may only be done via the appropriate LOCK command issued via the serial interface available through User Serial Port 2. (See command description below.)

Once a switch input is locked, the corresponding LED of locked input will flash RED for a short duration and then go out signifying the switch input will no longer respond to presses. Any other switch inputs also locked will also flash their corresponding LED RED in unison.

In the event the switch input that is locked is also the currently selected source input then the LED will flash RED for a short duration as above but then return to the GREEN status, indicating the source remains selected.

The user may restore switch input recognition of any locked input by issuing the UNLOCK command for the specified input. Any switch inputs remaining locked will flash RED for a short duration and the specified unlocked input's LED will return to its lit status of RED, if not the currently selected input, or will remain GREEN, indicating it remains as the currently selected source input.

The user may also LOCK or UNLOCK ALL inputs simultaneously.

POWERING THE MONITOR ON/OFF SERIALLY

The HV-CTL also allows the user to power the monitor ON/OFF via the serial interface (see command description below).

The user may power the monitor ON via the serial PWR ON command. The behavior of the LEDs when the monitor is powered ON or OFF is the same as that when it is powered on via the appropriate switch input previously described. That is, when powered OFF, the HV-CTL LEDs will all flash RED for a short duration and then all LEDs will be unlit, thereby indicating the monitor is powered OFF. When powered ON, the HV-CTL LEDs will all flash GREEN for a short duration and then return to the status indicating the current source input lit GREEN with all other inputs either RED or unlit (indicating the switch input is locked).

HUDDLE VU SERIAL COMMANDS

The HV-CTL supports a serial command interface that allows the user to configure the HV-CTL and to query current status via User Serial Port 2. Some of the commands duplicate the functionality available via the switch inputs, allowing the user to set the current source input and power the monitor ON or OFF. (See below for a complete description of the available commands.)

HV-CTL REQUEST LIST QUICK REFERENCE

REQUEST	DESCRIPTION
CON	Connect specified input to HDMI output.
HLP	Provides help information for HV-CTL command set.
LOCK	Lock a specified input from switch recognition.
PWR	Controls the state of the HV-CTL switched AC receptacles and AUX relay output.
RLY	Controls the state of the HV-CTL switched AC receptacles and AUX relay output.
RSP	Enable/Disable a response from HV-CTL to a command.
SBR	Configure serial bit rate of serial ports 1 or 2.
STA	Request status of currently connected input and power.
UNLOCK	Unlock a specified input for switch recognition.
VER	Request current part # and version number.
VRB	Turns on/off verbose command error reporting.

REQUEST/RESPONSE FORMAT

All requests and responses are entirely in ASCII. The requests can be in either upper or lower case.

All requests/responses have a type field followed by the data required for that specific request/response. All requests are terminated with a carriage return (0Dh), which is referred to in this document as `<cr>` or with a semi-colon character (;). The semi-colon permits the user to enter multiple commands in a single line of ASCII text. All responses are terminated with a carriage return `<cr>` and a line feed (0Ah) which will be referred to as `<lf>`.

Field Separators

Fields are separated by *white* space, that is, any number of spaces or tabs as long as the entire command is less than 256 characters. A `<cr>` terminates the command. Below is an example describing a command.

EX 05 `<cr>`

So the actual message would look like this:

EX 05`<cr>`

COMMAND REQUEST SYNTAX:

This document uses the following notation when describing the syntax of a command request:

BOLD – identifies the command

lower case – identifies data to be entered which is described in the text following the syntax description

" " - entry defined within double quotes is to be entered exactly as shown

< > - entry defined within these brackets is required

[] - entry defined within these brackets is optional

{ } - entry defined within curly brackets must be entered at least once

| - a vertical bar denotes a logical choice of entry

* - an asterisk following either [] brackets or curly brackets { } above denotes that data within either brackets or curly brackets may be entered multiple times.

COMMAND REQUEST COMMENT FIELDS

The ASCII syntax of the request protocol accommodates the ability to optionally insert comments into the Command Request. Comments must be enclosed within the # character. The comments are ignored by the Huddle-VU.

Example:

Below is an example of uncommented connection commands.

CON 1`<cr>`

LOCK 4`<cr>`

The above could have comments added as follows:

CON 1 # Laptop 1# `<cr>`

LOCK 4 #Limited access# `<cr>`

ACKNOWLEDGING RECEIPT OF COMMANDS

Each request sent to the HV-CTL have by default two possible responses, an acknowledgement of a correct request or an error response. The acknowledge response will be:

Ok<cr><lf>.

The HV-CTL may also be configured via command (see below) to suppress all responses. The user should exercise care when configuring no response as the user will obviously have no feedback as to the success of the command.

ERROR RESPONSE

In the event an invalid *command* is sent to the HV-CTL, it will respond with the message "**ERR: unknown command**". If an invalid parameter is sent to the HV-CTL, the unit will respond with the message "**ERR:** " followed by the valid syntax for the errored entry.

Example:

A connect request with an incorrect input number:

CON 8<cr>

The error response would be:

ERR: CON <"1"|"2"|"3"|"4"|"5"|"6"|"7">|<"?"><cr>

Note that the returned error response may be expanded to a more detailed version by entering *verbose mode*. This mode may be turned on by issuing a VRB Y command. The expected syntax for the command will be returned, as above, and a description of each parameter.

For example, if verbose mode were turned on and the above command issued, the response would be:

ERR: CON <"1"|"2"|"3"|"4"|"5"|"6"|"7">|<"?"><cr>

Connect specified program input

"1"|"2"|"3"|"4"|"5"|"6"|"7" Input to connect

"?" ? for inquiring currently configured source.

CONNECTION REQUEST

The **CON** request is used to connect an input to the monitor. Only one input can be connected at any one time. The specified input causes the HV-CTL to configure the 4x1 HDMI switchers appropriately.

CON	<i><input_to_connect></i> <i><"?"></i>	<i><cr></i>
------------	--	-------------------

Syntax:

CON *<input_to_connect >* | *<"?">**<cr>*

Where:

CON Connection request header

input_to_connect = 1,2,3,4,5,6 or 7.

"?" to query the current input setting.

Example:

To connect input 2 to the monitor:

CON 2*<cr>*

To query the currently connected input:

CON ?*<cr>*

HELP REQUEST

The user will be able to request a list of the valid commands with descriptions and formats. The format for this request is as follows:

HLP	[cmd]	<cr>
------------	-------	------

HLP [cmd] <cr>

Syntax: HLP [cmd]<cr>

Where:

HLP Help Request header

cmd optional command identifier

If the optional *cmd* is omitted, the HV-CTL will respond with the following text message:

CON	Connect specified input.
HLP	Provides help information for HV-CTL command set.
LOCK	Lock a specified input from switch recognition.
PWR	Controls the state of the HV-CTL switched AC receptacles and AUX relay output
RLY	Controls the state of the HV-CTL switched AC receptacles and AUX relay output
RSP	Request or decline a response.
SBR	Configure serial bit rate of serial port 1 or 2.
STA	Request status of currently connected input.
UNLOCK	Unlock a specified input for switch recognition.
VER	Request current part # and version number.
VRB	Turns on or off verbose command error reporting.

Entering **HLP** <cmd><cr>, where cmd is any valid HV-CTL command in the above list, will return specific help syntax for the command requested. If the user would like more detailed help for a specific command then it is necessary to turn on *verbose mode* using the **VRB Y** command syntax. This will enable returning a description of the parameters of any specific command. The user may return to *non-verbose mode* by issuing the **VRB N** command.

Specific command help is listed below.

```
CON <"1"|"2"|"3"|"4"|"5"|"6"|"7"> |<"?"><cr>
    Connect specified program input
    "1"|"2"|"3"|"4"|"5"|"6"|"7" Input to connect
    "?"          ? for inquiring currently configured source.
```

```
HLP[ cmd]<cr>
    Provides help information for the HV-CTL command set.
    cmd optional command identifier
```

```
LOCK <"1"|"2"|"3"|"4"|"5"|"6"|"7">|<"ALL"> |<"?"><cr>
    Lock a specified switch input from recognition.
    1-7 = Switch input to be ignored.
    "ALL" = Lock all switch inputs.
    "?" = Request current lock status.
```

PWR <"ON"|"OFF"><cr>

Controls the state of the HV-CTL switched AC receptacles and AUX relay output

RLY <"ON"|"OFF"><cr>

Controls the state of the HV-CTL switched AC receptacles and AUX relay output

RSP <"Y"|"N"><cr>

Turns on or off a response from HV-CTL.

"Y"|"N" "Y" enables a response, "N" disables.

SBR <"S1"|"S2"> <"1"|"2"|"3"|"4"|"5"|"6"> | <"?">

Configure the serial bit rate of serial ports 1 or 2.

S1 = Serial Port 1, S2 = Serial Port 2.

1=2400, 2=4800, 3=9600, 4=19200, 5=38400, 6=57600, ? = inquiry.

STA<cr>

Status request returns the currently connected input and monitor status:

STA CON = <Number> PWR <ON|OFF>

Number Input (1-7) that is currently connected

ON|OFF Current monitor status

UNLOCK <"1"|"2"|"3"|"4"|"5"|"6"|"7">|<"ALL">|<"?"><cr>

Unlock a specified switch input.

1-7 = Switch input to be unlock.

"ALL" = Unlock all switch inputs

"?" = Request current unlock status

VER<cr>

Version request returns the following:

VER <Part#> <Revision#><cr>

Part# "HV-CTL"

Revision# XX.xx, XX=Major revision number, xx=Minor revision number

VRB <"Y"|"N"><cr>

Turns on or off verbose error message reporting.

"Y"|"N" "Y" turns verbose on, "N" turns verbose off.

LOCK REQUEST

The **LOCK** request is used to prevent the specified switch input(s) from being recognized.

LOCK <i><input_to_lock></i> <i><"ALL"></i> <i><"?"></i> <i><cr></i>
--

Syntax:

LOCK *<input_to_lock>* | *<"ALL">* *<"?">**<cr>*

Where:

LOCK request header

input_to_lock = 1,2,3,4,5,6 or 7.

"ALL" = Lock all switch inputs

"?" to query the currently locked switch inputs.

Example:

To LOCK input 2 from being recognized:

```
LOCK 2<cr>
```

To LOCK all switch inputs from being recognized:

```
LOCK ALL<cr>
```

To query the currently locked switch inputs:

```
LOCK ?<cr>
```

POWER REQUEST

The **PWR** request allows the user to turn the monitor on or off.

PWR	<"ON" "OFF">	<cr>
------------	--------------	------

Syntax:

PWR <"ON"|"OFF"><cr>

Where:

PWR request header

"ON" = Turns AC receptacles and AUX relay output on.

"OFF" = Turns AC receptacles and AUX relay output off.

Example:

PWR ON<cr>

RELAY REQUEST

The **RLY** request allows the user to turn the relay on or off. This is functionally equivalent to the PWR request.

RLY	<"ON" "OFF">	<cr>
------------	---------------------------	-------------------

Syntax:

RLY <"ON"|"OFF"><cr>

Where:

RLY request header

"ON" = Turns AC receptacles and AUX relay output on.

"OFF" = Turns AC receptacles and AUX relay output off.

Example:

RLY ON<cr>

RESPONSE REQUEST

The **RSP** request allows the user to turn on/off responses to commands to the HV-CTL should they so desire. The default configuration on a power cycle is to send responses.

RSP	<"Y" "N">	<cr>
------------	-----------	------

Syntax:

RSP <"Y"|"N"><cr>

Where:

RSP request header

"Y" = Send responses to commands.

"N" = Don't send responses to commands.

Example:

RSP Y<cr>

SERIAL BIT RATE REQUEST

The **SBR** request allows the user to configure the bit rates of User Serial Ports 1 and 2 connected to the HDMI 4x1 switchers. The default rate is 38400 bps for each and is not expected to change, but this command allows for possible future changes, if necessary.

SBR	<<"S1" "S2"><"1" "2" "3" "4" "5" "6">> <"?">	<cr>
------------	--	------

Syntax:

SBR <<"S1"|"S2"><"1"|"2"|"3"|"4"|"5"|"6">> | <"?"><cr>

Where:

SBR request header

"S1"|"S2" = Specifies User Serial Port 1 or 2.

"1"|"2"|"3"|"4"|"5"|"6" 1=2400, 2=4800, 3=9600, 4=19200, 5=38400, 6=57600

"?" ? = Inquiry of current rates on each port.

Example:

To configure serial port 1 to 38400 bps:

```
SBR S1 5<cr>
```

To configure serial port 2 to 2400 bps:

```
SBR S2 1<cr>
```

To query the current settings:

```
SBR ?<cr>
```

The unit responds with:

```
S1 = 5 = 38400 bps
```

```
S2 = 1 = 2400 bps
```

NOTE: The responses occur at the original baud rate before the change takes effect.

STATUS REQUEST

The **STA** request returns the current source input and monitor status.

STA	<i><cr></i>
------------	-------------------

Syntax:

STA*<cr>*

Where:

STA request header

Response: STA CON = *<source_input>* PWR *<monitor_status>*

Where:

source_input = currently connected source input, 1-7.

monitor_status = current monitor status, ON or OFF.

Example:

STA*<cr>*

To which the HV-CTL will respond if current source input is 5 and power is on:

STA CON = 5 PWR ON HV-CTL 01.02

UNLOCK REQUEST

The **UNLOCK** request re-enables recognition of the specified switch input(s).

UNLOCK <i><input_to_unlock></i> "ALL" "<?>" <i><cr></i>
--

Syntax:

UNLOCK *<input_to_unlock>* | "<ALL"> "<?>"<cr>

Where:

UNLOCK request header

input_to_unlock = 1,2,3,4,5,6 or 7.

"ALL" = Unlock all switch inputs

"?" to query the currently unlocked switch inputs.

Example:

To UNLOCK input 2, allowing it to be recognized:

UNLOCK 2<cr>

To UNLOCK all switch inputs:

UNLOCK ALL<cr>

To query the currently unlocked switch inputs:

UNLOCK ?<cr>

VERSION REQUEST

The user may request a description of the part number and the current firmware version number by making this **VER** request. The format for the request will be as follows:

VER	<cr>
------------	-------------------

Syntax:

VER<cr>

Where:

VER request header

Response: **VER** <Part#> <Revision#>

Where:

Part# = HV-CTL

Revision# = XX.xx, XX = Major version number, xx = Minor version number.

Example:

VER<cr>

To which the HV-CTL will respond:

VER HV-CTL 01.02

VERBOSE REQUEST

The user can, during debugging, turn on verbose mode to expand the standard error message describing the syntax to include a description of the command parameters. Verbose mode is off by default.

VRB	<"Y" "N">	<cr>
------------	-----------	------

Syntax:

VRB <"Y"|"N"><cr>

Where:

VRB request header

"Y" = Turns verbose mode on.

"N" = Turns verbose mode off.

Example:

VRB Y<cr>

If the user tries to connect an invalid input, the standard error message would look something like this:

ERR: CON <"1"|"2"|"3"|"4"|"5"|"6"|"7"> | <"?"><cr>

If the user enabled verbose mode then the response would be as follows:

ERR: CON <"1"|"2"|"3"|"4"|"5"|"6"|"7"> | <"?"><cr>

Connect specified program input

"1"|"2"|"3"|"4"|"5"|"6"|"7" Input to connect

"?" ? for inquiring currently configured source

DV-HSW-41 PINOUTS AND CABLING

DB-9 CONNECTION

Please see the HuddleVU serial protocol manuals included with the product for serial commands and other details on RS-232 control. Use a null modem cable for controlling.

RS-232 HARDWARE CONFIGURATION	
BAUD RATE	38400
DATA BITS	8
STOP BITS	1
PARITY	NONE
FLOW CONTROL	NONE

PORT 2 RS-232 / DB-9 socket

- 1.N/C
- 2.RX (Receive data) (Input)
- 3.TX (Transmit data) (Output)
- 4.N/C
- 5.GND (Signal return)
- 6.N/C
- 7.CTS (Clear to send) N/C
- 8.RTS (Request to send) N/C
- 9.N/C

NOTE:

The HuddleVU serial ports are configured as "DTE" and connect to the HDMI switchers with a null modem cable, since the switchers are also configured as "DTE".

If connecting to a control system or computer serial port that is also DTE, you will need to use a null modem cable.

SPECIFICATIONS

HV-CTL

120Vac 12A, 60Hz
3 switched AC receptacles, combined 12A max
12Vdc relay drive output
Video select indicators
Power switch and circuit breaker
Plug and play installation
Supports up to 7 sources
ETL approved

DV-HSW-41

HDMI 1.3
HDCP 2.1
2.25 Gbps (Single Link)
Up to 1080p (1920 X 1080, 60Hz)
Up to UXGA (1600 X 1200, 75Hz)
Video select Indicator
RS-232 data indicators
Power ON Indicator
Video input: 4 Female Type A HDMI
Video output: 1 Female Type A HDMI
RS-232: 2 Female DB-9
5Vdc 2A

DV-PC2HD

Supported resolutions

Video Resolutions supported by the DV-PC2HD @ 60 Hz		
1920 x 1080	1680 x 1050	1600 x 1200
1600 x 1024	1600 x 900	1440 x 900
1360 x 1024	1366 x 768	1360 x 768
1280 x 1024	1280 x 960	1280 x 900
1280 x 800	1280 x 768	1280 x 720
1152 x 864	1024 x 768	800 x 600
	640 x 480	

HDMI 1.3
HDCP 1.2
Video input: Female HD-15
Analog audio input: 3.5mm jack
Video output: Female Type A HDMI
Power ON Indicator
5Vdc 1A
Note: Audio will not pass-through without a video signal.

IT-SACWP

Device rated current: 12A (switches standard 15 amp circuit subject to a 20% UL derating)

Operate time: 15ms max

Coil rating: 12VDC @ 90mA

Minimum operating voltage: 10VDC

Contact rating: 30A @ 120VAC (100,000 cycles)

1 HP motor load (1,000 cycles)

6A ballast load (100,000 cycles)

5A Tungsten load (6,000 cycles)



205 Westwood Ave, Long Branch, NJ 07740

Phone: 866-94 BOARDS (26273) / (732)-222-1511

Fax: (732)-222-7088 | E-mail: sales@touchboards.com

WARRANTY AND RETURN INFO

WARRANTY POLICY

This product is warranted against failures due to defective parts or faulty workmanship for a period of one year after delivery to the original owner. During this period, FSR will make any necessary repairs or replace the unit without charge for parts or labor. Shipping charges to the factory or repair station must be prepaid by the owner, return-shipping charges, via UPS / FedEx ground, will be paid by FSR.

This warranty applies only to the original owner and is not transferable. In addition, it does not apply to repairs done by other than the FSR factory or Authorized Repair Stations.

This warranty shall be cancelable by FSR at its sole discretion if the unit has been subjected to physical abuse or has been modified in any way without written authorization from FSR. FSR's liability under this warranty is limited to repair or replacement of the defective unit.

FSR will not be responsible for incidental or consequential damages resulting from the use or misuse of its products. Some states do not allow the exclusion of incidental or consequential damages, so the above limitations may not apply to you. This warranty gives you specific legal rights, and you may also have other rights which vary from state to state.

Warranty claims should be accompanied by a copy of the original purchase invoice showing the purchase date (if a Warranty Registration Card was mailed in at the time of purchase, this is not necessary). Before returning any equipment for repair, please read the important information on service below.

SERVICE AND RETURN AUTHORIZATION

Before returning any equipment for repair, please be sure that it is adequately packed and cushioned against damage in shipment, and that it is insured. We suggest that you save the original packaging and use it to ship the product for servicing. Also, please enclose a note giving your name, address, phone number and a description of the problem.

NOTE: All equipment being returned for repair must have a Return Authorization (RMA) Number. To get a RMA Number, please call FSR Service Department (973-785-4347).

Please display your RMA Number prominently on the front of all packages.

CONTACT INFORMATION

FSR Inc.
244 Bergen Boulevard,
Woodland Park, NJ 07424

Tel: 1-800-332-FSR1 973-785-4347 Fax: (973) 785-4207

E-Mail: sales@fsrinc.com · Web: <http://www.fsrinc.com>