

FSR

Touchboards

205 Westwood Ave, Long Branch, NJ 07740
Phone: 866-94 BOARDS (26273) / (732)-222-1511
Fax: (732)-222-7088 | E-mail: sales@touchboards.com

ML-116

ROOM COMBINING SYSTEM

INSTALLATION MANUAL

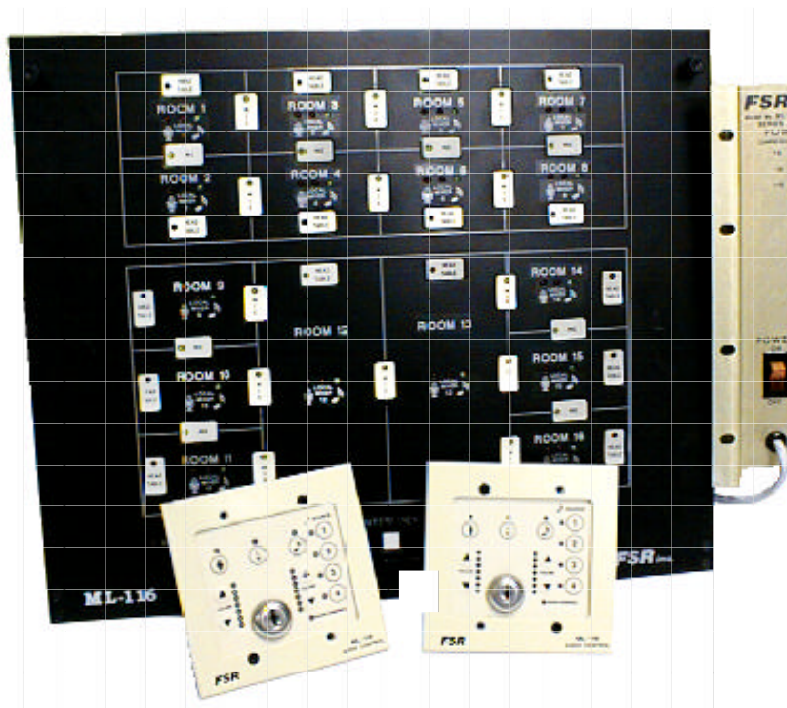

244 Bergen Boulevard, West Paterson, NJ 07424 Tel 973-785-4347 Fax 973-785-3318
E-Mail sales@fsrinc.com Web www.fsrinc.com

ML-116 INSTALLERS MANUAL

CONTENTS

Introduction.....	5
Unpacking.....	6
Photograph of System Components.....	7
Equipment Placement.....	8
Grounding.....	8
System Block Diagram.....	9
Overall View of the System Components.....	11
• Wallplate	
• ACU	
• Monitor/VU Panel / Monitor/VU Hookup	
System Specifications.....	16
Audio Connector Wiring.....	19
Cabling.....	20
• Audio	
• Control	
• Wallplates	
System Configuration.....	22
Dip Switch / Jumper Settings.....	23
• ACU	
CPU Card	
RA2 Cards	
• Wallplates	
• Map Panel	
Adjustments.....	30
Paging System Operation.....	32
Head Table Operation.....	33
Facility Manager Panel Operation.....	34
Multiple ACU's.....	37
Remote Map and Monitor Panels.....	40
Audio / Lighting Systems Intergration.....	41
Map Panel Status Interface.....	42

INTRODUCTION

The design of the ML-116 system takes advantage of current technology to provide a blend of reliability, ease of use, flexibility, and reasonable cost. Designed for Hotels and Conference Centers with divisible, multi-use meeting rooms, the ML-116 unifies the audio system of each room being joined together with the touch of a button. Each control panel, speaker, amp, etc. will automatically operate as one sound system. Any number of rooms (up to 16 per system) can be combined in any number of groups. Provided custom software allows the system to be tailored to specific system requirements.

The ML-116 eliminates the need for skilled operators and can be used by staff members with minimum instruction. The combining can be controlled from multiple locations depending on the system options, and specific functions can be controlled from each room. The quality of the sound system is not compromised by this system. Built-in safeguards prevent system failure due to misuse or failure of one component.

The entire ML-116 system includes:

- o **ACU** Audio Control Unit (base ML-116 chassis)
- o **PSA** Power Supply
- o **Wallplates** One per room
- o **MLH-8/16/24/32** Head Table Speaker Controls (optional)
- o **MAP** Graphic Map Panel (optional)
- o **MON** Monitor/VU Panel (optional)
- o **FMP** Facility Manager Panel Interface (optional)
- o **AUD** Remote Audio Monitoring (optional)
- o **RMAP** Remote Map Panel (optional)
- o **RMON** Remote Monitor Panel (optional)
- o **TC** Remote Map and Monitor LCD Touch Panel (optional)
- o **CNTL** Control System Interface (optional)
- o **INT** Map Panel Status Interface (optional)
- o **LU** Lutron® Lighting Interface (optional)
- o **IM / UM** Installation Manual / User Manual

In each room a wallplate controls music and local input functions (local input on/off, room mixer enable, music select, and volume up/down switches for local input and music.) A bar graph display is provided for local input and music.

The security key switch prevents unauthorized control of the system. Dip switches inside the Audio Control Unit determine whether the key switch interlocks all the wallplate functions, microphone functions only, or no wallplate functions.

The system is shipped in a default setting which will permit instant operation of the system in its usual configuration. Please refer to the Dip switch/Jumper settings for pertinent details on the switch functions.

UNPACKING

Your ML-116 system should contain the following components;

- ACU (audio control unit) This is the large unit and may have the map panel, if ordered, on the front.
- ML-PSA (large power supply)
- Wall Plates Room control panels, one for each room in the system. Depending on the order either 2 or 3 gang wallplates will be shipped. On some installations two wallplates may be required per room.
- If head tables were ordered you should have an HTBC card, 1-4 HT-8 cards, power supply, and one or two 19 inch TRAC-BRACs depending on the number of HT-8 cards. Each HT-8 card will handle up to 8 Head Table locations.
- If the Monitor/VU panel was ordered you should have the Monitor Panel and ribbon connecting cable along with the Monitor Relay Card mounted on a 19 inch TRAC-BRAC.
- If the Facility Manager Panel was ordered you should have an FM-INT Interface Unit, the RS-232 interconnect cable, a 3.5" diskette, and a power supply. (*)
- If the Remote Audio feed was ordered you should have an enclosed audio speaker along with special relay cards (116-MNRL and 116-MNP) mounted on a 19 inch TRAC-BRAC. (*)
- If the Remote Map Panel was ordered you should have the R-MAP Panel with its power supply.
- If the Remote Monitor Panel was ordered you should have the R-MON Panel which will mount on top of the R-MAP Panel.
- If the Lutron lighting interface was ordered then you should have the ML-116-INT & power supply unit.
- An installation Manual.
- A users Manual.

(*) With multiple ML-116 systems with the FMP or AUX option(s) some duplicate components are not provided

ML-116 COMPONENTS

AUDIO CONTROL UNIT (GENERIC LAYOUT SHOWING 16 ROOMS)



OPTIONAL SUBSYSTEMS OF THE ML-116 SYSTEM



EQUIPMENT PLACEMENT

The ACU is mounted first. It should go in the audio rack at eye level usually 55 inches from the finished floor. The MONITOR VU panel is mounted next and it usually goes immediately above the ACU.

The ML-PSA is mounted in the same rack as the ACU. It mounts in the rear of the rack usually at waist level.

The Monitor Relay card, already mounted on the TRAC-BRAC is mounted directly behind the power amps on the rear rack rails.

If head tables were ordered then the HTBC and HT-8 cards, mounted on a TRAC-BRAC are located at the rear of the rack behind the power amplifiers.

When the Facility Managers software, with audio monitoring (ML-116-AUD), is ordered then another TRAC-BRAC with a ML-116-MNRL & MNP is also installed at the rear of the rack close to the Monitor Relay Card. This completes the rack mounting of the ML-116 components.

The wallplates are mounted next. At least one wallplate is mounted in each room. In larger rooms two wallplates may be required. They mount in a standard 2 gang electrical box (min. depth 3 inches) and are connected to the cable already pulled. Refer to the section on wallplates to determine proper hook-up.

If the Facility Managers software with audio monitoring (ML-116-AUD) was ordered then the enclosed audio speaker, as well as the FM-INT small desk top mounted box, are located in the Managers Office.

If the Remote Map and/or Monitor Panel was ordered then this unit will be mounted, most likely, in a service corridor and will be wired back to the rack mounted ACU.

If the lighting interface was ordered then the ML-116-INT) unit would be mounted in the lighting dimmer rack location

GROUNDING

It is strongly recommended that in any rack setup to ensure appropriate power application as well as superior power surge protection that the FSR Power Conditioning and Sequencing (SPC) System be utilized.

The ML-116 System, along with the associated mixers, equalizers, and power amplifiers, is a high gain audio system of some complexity and requires a proper grounding procedure be followed.

The ML-116 equipment has separate audio, digital, and chassis grounds. In some cases you may need to connect the two grounds. The digital and audio grounds come together on the regulator card located inside the audio control unit on the left side of the chassis. There is a ground terminal and when it is connected to a banana jack on this same card the digital and audio grounds will be tied to the chassis ground.

WALLPLATE GROUNDING CONSIDERATIONS

In order to prevent damage to the ML-116 system from ESD (Electro-Static Discharge), it is incumbent upon the installer to carefully consider the grounding of the system. Since the ML-116 is a digital/audio hybrid, proper ground is essential to maintaining audio quality while preventing damage the electronic circuitry.

The metal faceplate of the ML-116 wallplates must be grounded to prevent damage due to ESD events. The best way to guard against ESD damage in any system is to return the charge to ground by the shortest path possible. A direct connection between the faceplate and conduit ground is the most desirable method. At the same time, the DC ground of the system must be kept isolated from conduit ground, or ground loop noise will result.

The ML-116 wallplates are provided with either a ground wire or a ground jumper to allow for grounding of the metal faceplate. If the electrical mounting boxes are already grounded, the ground wire must be insulated or the jumper disconnected to prevent a ground loop. If the electrical box is not grounded, connect the ground wire to the SHIELD terminal of wallplates so equipped. On wallplates that have a ground jumper, ensure that the jumper is installed. In systems that do not have grounded electrical boxes, the ESD ground path is through the shield conductor of the recommended cable, through the ML-116's CPU card, and to the chassis of ML-116 rack unit.

ML-116 SYSTEM BLOCK DIAGRAM

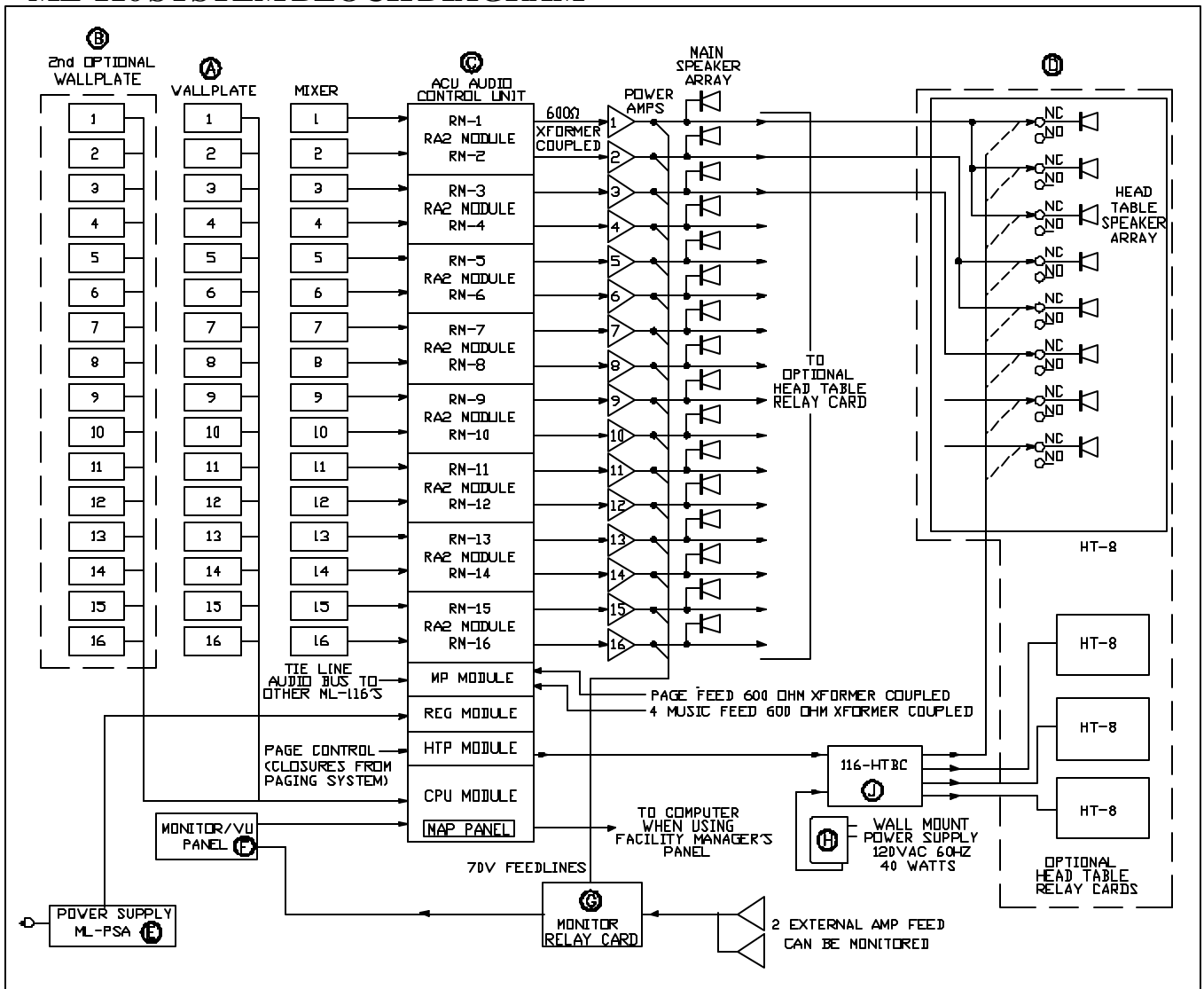

- A.....** There will be two types of wallplates available for use in the ML-116 system; membrane and LCD. Both control all wallplate functions. These functions include Music Selection, Room Mixer Enable, Music Enable and Volume, and Local Input On/Off and Volume.
- B.....** Each room in the system can have two wallplates if desired.
- C.....** The ACU (audio control unit) is the main unit of the system. It routes the selected music, adjusts levels, combines rooms, handles communications (between wallplates, map, and monitor panels), and can talk to other ML-116s. It also controls the paging function.
- D.....** The HT-8 is a PC board assembly with 8 relays to control the speaker feeds to the head table locations. These cards are driven by the HTBC board.
- E.....** The PSA is the Power Supply for the ML-116 system.
- F.....** The Monitor/VU Panel permits an operator to monitor the audio from any selected room. It also permits the operation of any wallplate function from this same panel.
- G.....** The Monitor Relay Card is a PC board assembly of relays that mounts close to the power amps and provides the audio feed for the monitor panel.
- H.....** This wall plug-in transformer powers the HTBC and HT-8 cards.
- J.....** The HTBC Board is essentially a breakout that accepts power and signal input and drives the HT-8 cards.

These three remaining items are described and shown further on in this document.

- K.....** This is the R-MAP unit that repeats the data on the rack map panel (see page 40)
- L.....** This is the R-MON unit that repeats the data on the rack monitor panel (see page 40)
- M.....** This is the ML-116-INT unit to handle the lighting interface (see page 42)

OVERALL VIEW OF SYSTEM COMPONENTS

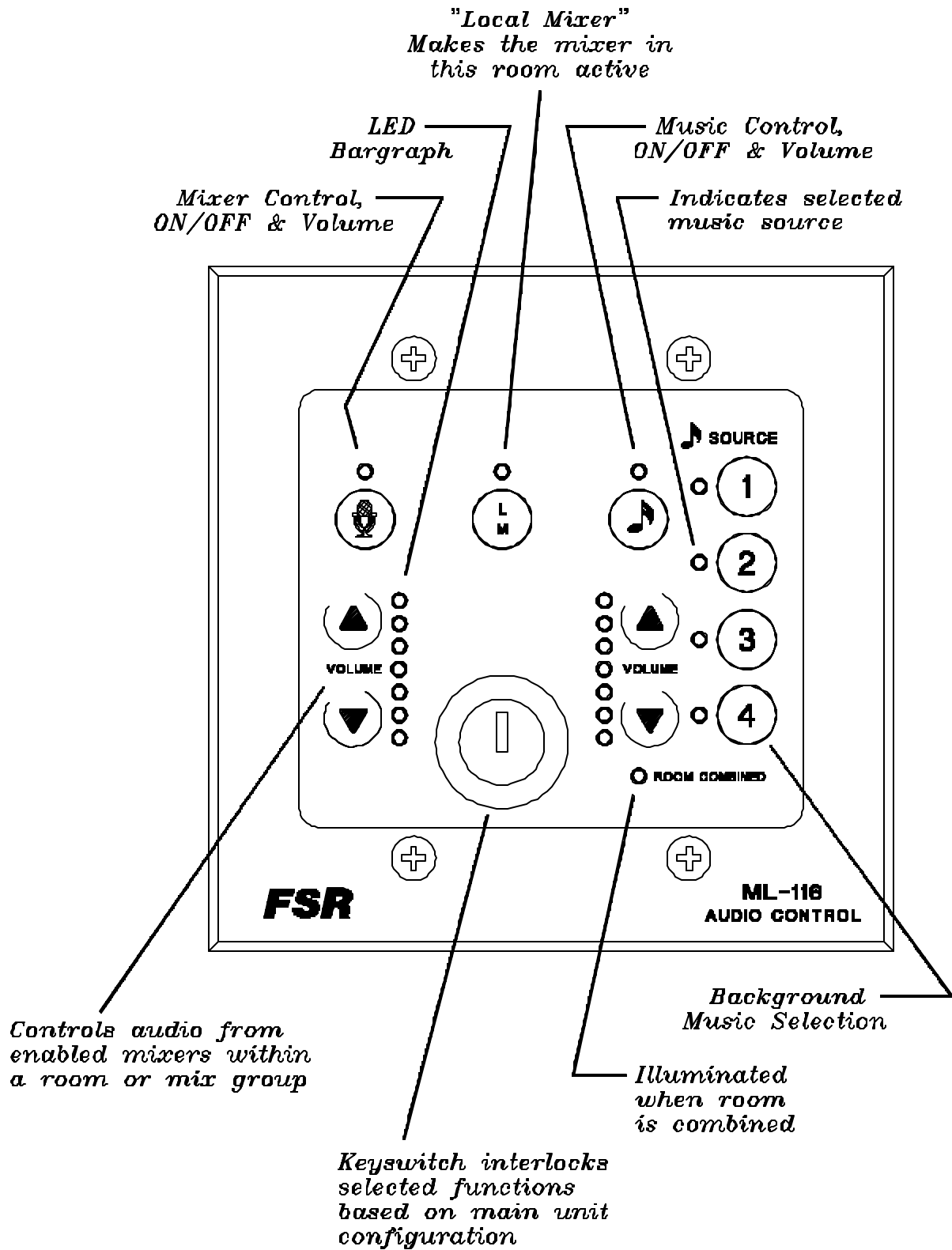

ML-116 WALLPLATE 2 Gang

MEMBRANE TYPE

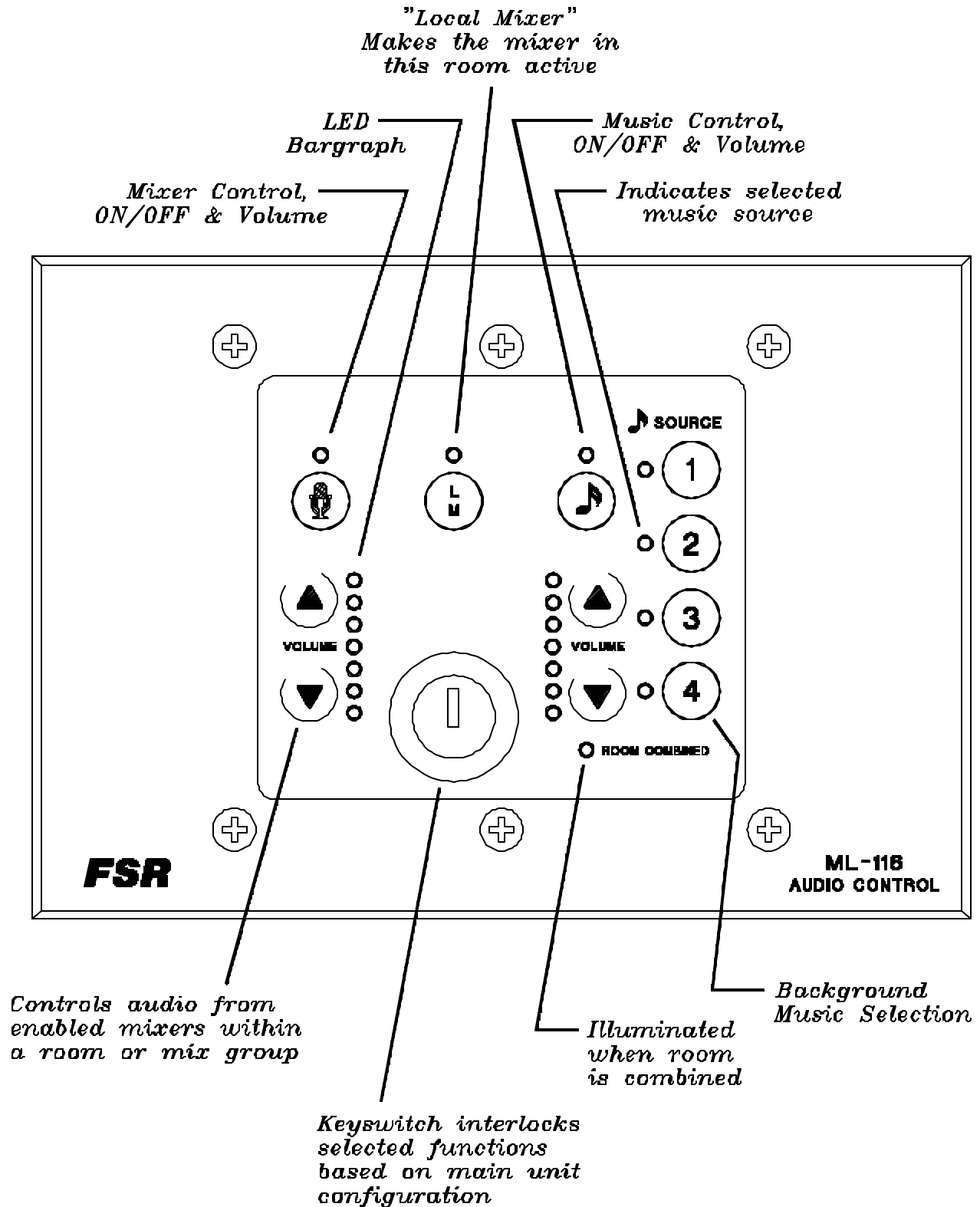

ML-116 WALLPLATE 3 Gang MEMBRANE TYPE

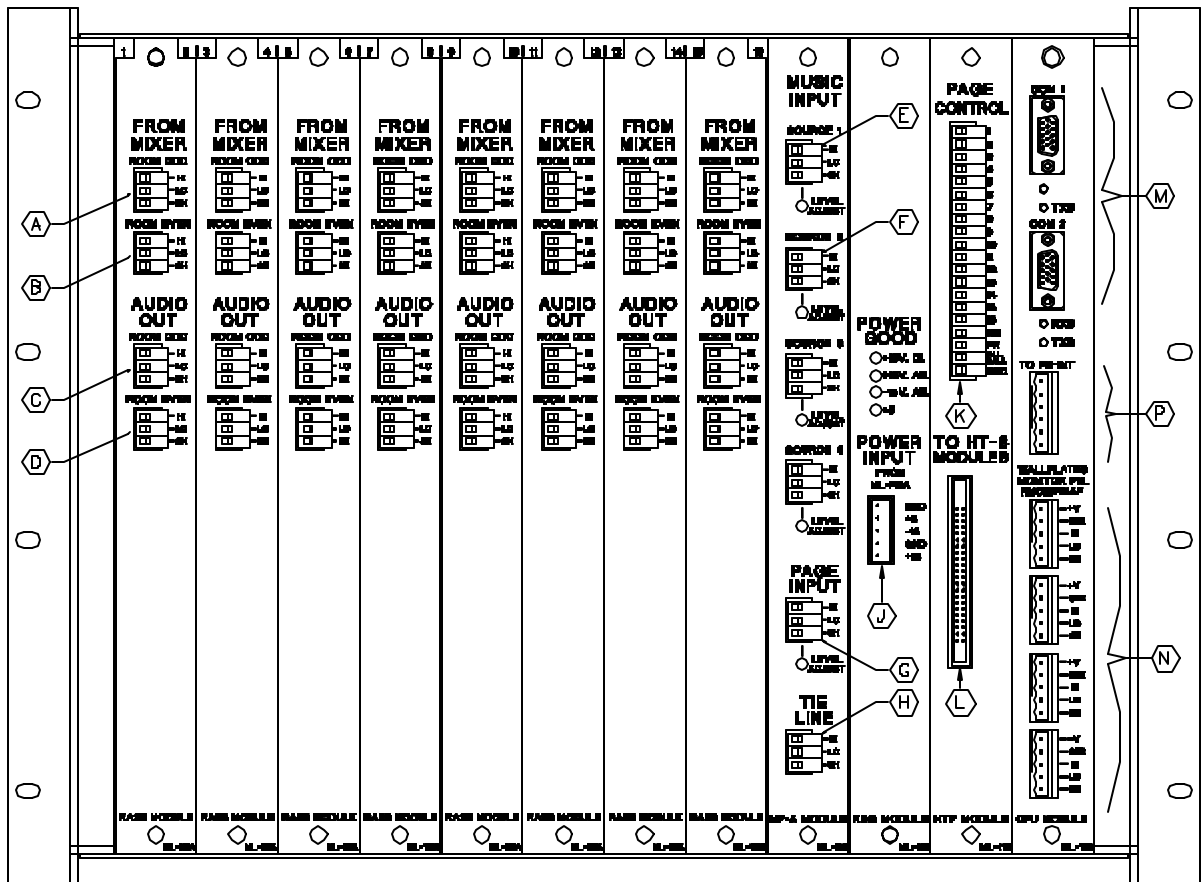

ACU Description

The Audio Control Unit is the main unit of the system. It routes the selected music, adjusts levels, combines rooms, handles communication (between wallplates, map, and monitor panels), and can route audio to other ML-116s. It also controls the paging function.

Refer to Figure 1 for the following discussion.

The ACU RA2 module provides the audio interface for two rooms. All RA2 modules are fully interchangeable. The module identifies the two rooms by an ODD and EVEN nomenclature. The numbers that appear on the top of the ACU module slot refer to the room's number in the system. These numbers also correspond to the numbers in each room drawn on the map panel.

A...This 3 pin connector receives the audio signal from the ODD room's mixer.

B...This 3 pin connector receives the audio signal from the EVEN room's mixer.

C...This 3 pin connector provides the audio output to the ODD room's amplifier or EQ.

D...This 3 pin connector provides the audio output to the EVEN room's amplifier or EQ.

E...These four 3 pin connectors receive the background music signals from the facility supplied sources. The source number over each connector corresponds to the identification called out on the room wallplates.

F...This trim control provides limited volume adjustment for each background music source.

G...This 3 pin connector accepts the page audio signal from the facilities page audio feed. A level adjust is provided for this input.

H...This 3 pin connector may be used to provide limited combining capability among multiple ML-116 systems.

J...The ML-116 regulator module accepts unregulated DC voltages from the ML-116 PSA, power supply. A plugable connection is provided to connect to the power supply. LED indicators are provided to monitor the power within the unit.

K - L...The HTP module provides control interface to support paging capabilities. It also provides the control interface for the head table speaker switching. Refer to sections titled Paging and Head Table operation for additional details

M...Com 1 and Com2 update serial ports (DB-9 x

2 male)

N...Wallplate/monitor interface connectors. These four points are where all room wallplates are connected. The monitor panel, the remote map/monitor and the ML-116-INT interface unit are connected to one of these points. Four points are provided to ease system installation.

P...Facility managers panel interface connector. Refer to section on this topic for additional details.

MONITOR/VU PANEL

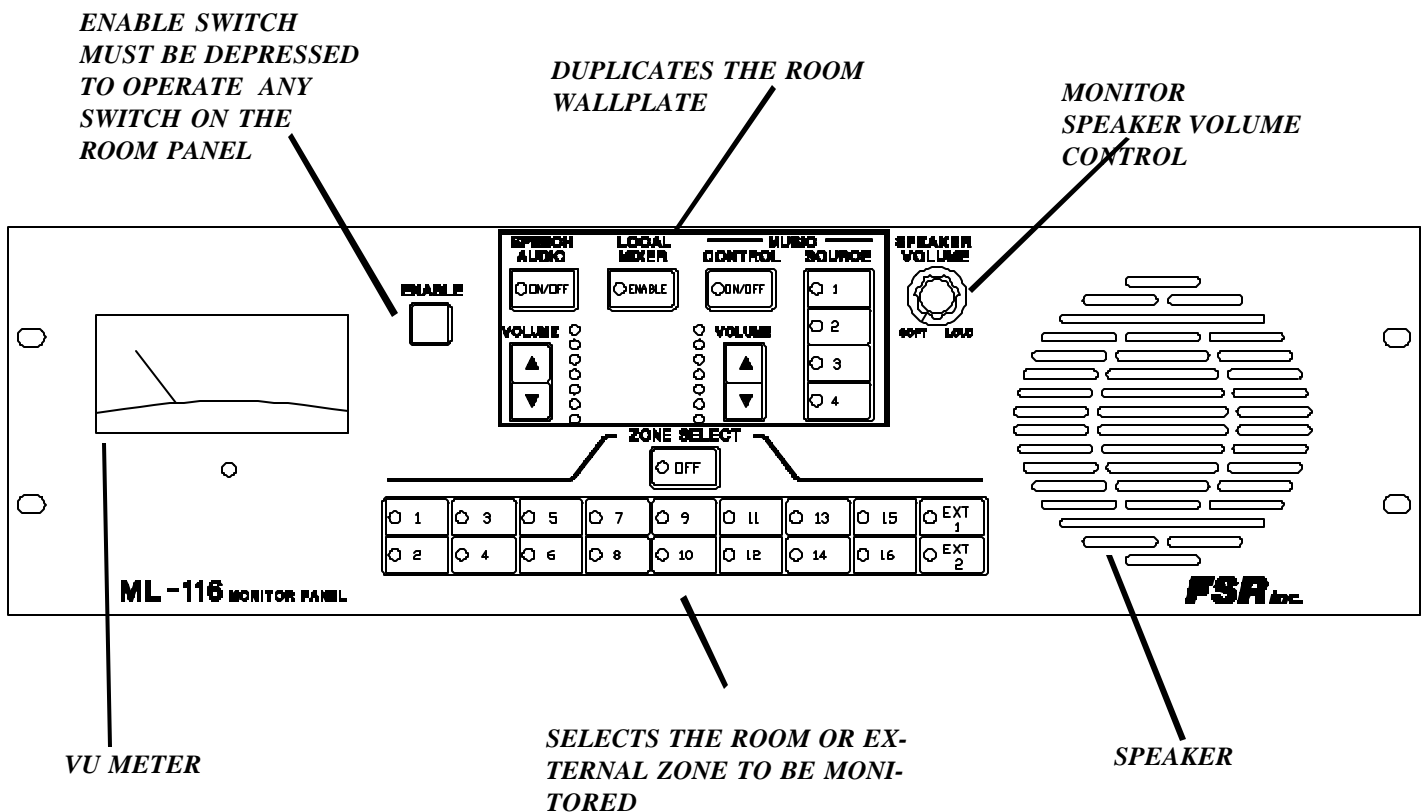

Monitor/VU Panel Installation

While the Monitor/VU panel is optional, it is recommended for all systems comprising more than six rooms. The installation of this feature requires the Monitor Relay Card in addition to the above panel. This relay card is supplied mounted in an FSR TRAC-BRAC simplifying the rear rack mounting of this card.

The interconnect cable from the ML-116 ACU to the Monitor panel is the same wire used to connect the wallplates. The cable from the Monitor panel to the Monitor relay card is supplied with the system.

Monitor/VU hookup diagram

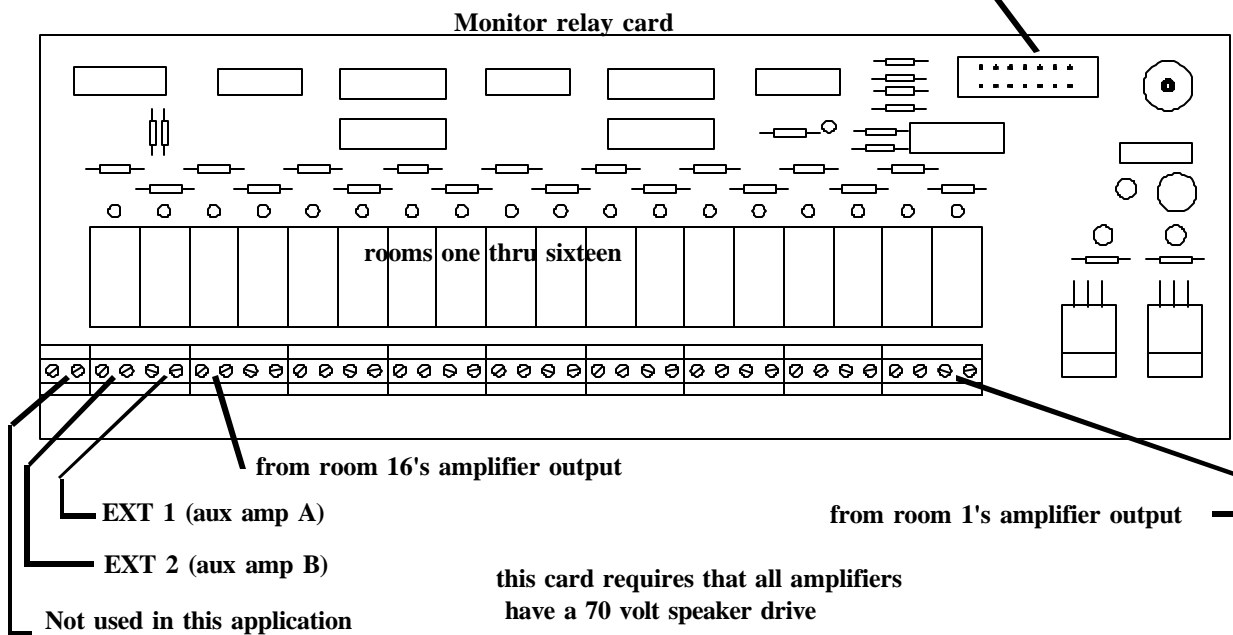
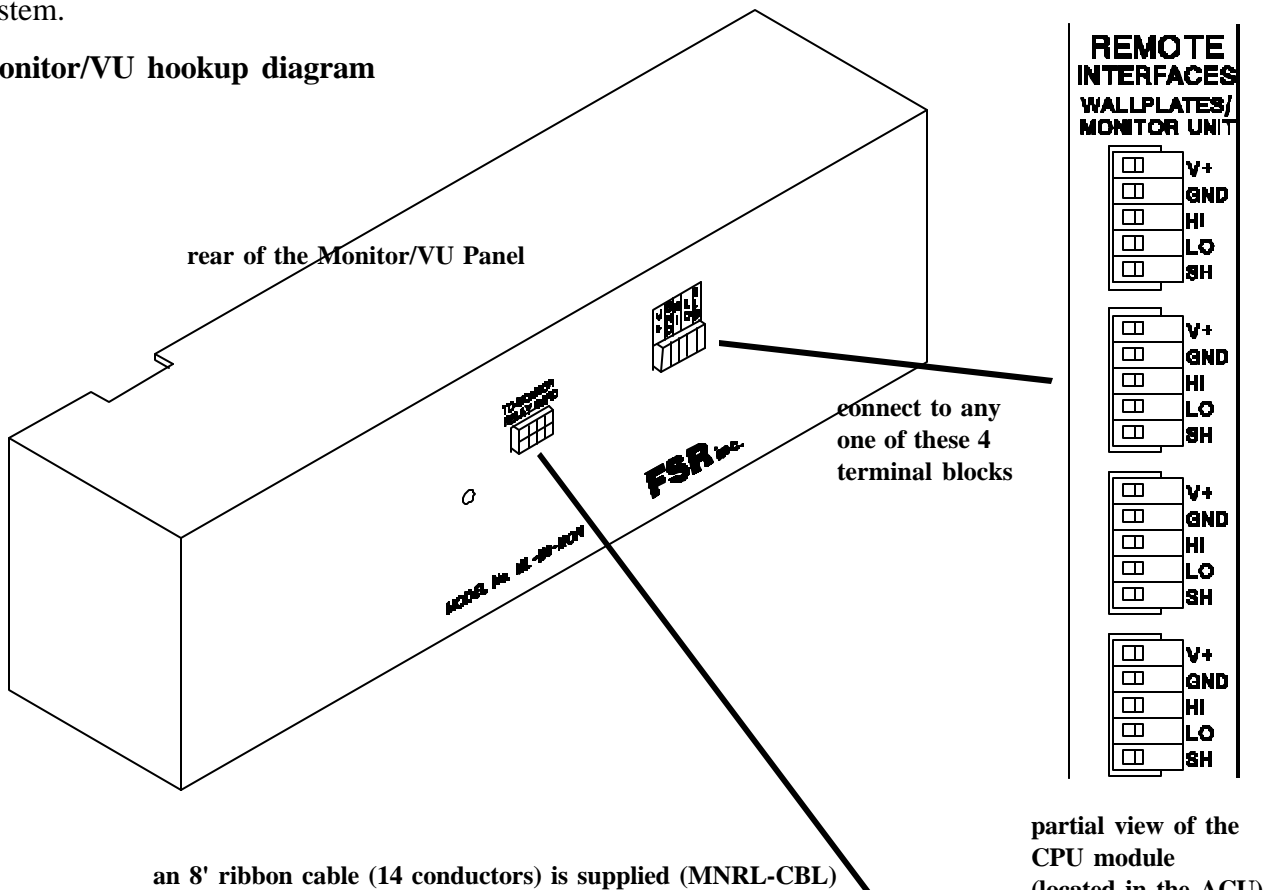

SYSTEM SPECIFICATIONS

Audio Control Unit (ACU)

Audio Connections: RA2 Module (one per two rooms)

Inputs: electronically balanced 20K Impedance (unbalanced 10K), 3 pin screw terminals

Outputs: 600 ohm transformer coupled (balanced) 3 pin screw terminals

Audio Connections: MP Module (music/page module)

Inputs: 600 ohm transformer coupled (balanced) 3 pin screw terminals

System Level adjust range: +7 dB to -20 dB

Input TrimLevel Adjust Range: (Page and Music input level adjust trim pots) +2.5 to -7.5 dB.

Tie line output: 600 ohm transformer coupled (balanced) 3 pin screw terminals

Audio Gain:

Music (with respect to input level)

Volume Reset: 0 dB +/- 1dB

Full Down: -18 dB +/- 1 dB

Full Up: +4 dB +/- 0.5 dB

Local Input (with respect to input level)

Volume Reset: 0 dB +/- 1dB

Full Down: -18 db +/- 1 db

Full Up: +4 db +/- 0.5 db

Page Input: 0 db +/- 1 db

Maximum Output Level: +20 dBm

Noise Floor: -75 dBm typical. Conditions: Full mix, Mixer Enables on, Local Inputs off, input open, outputs 600 ohm terminated

-70 dBm typical. Conditions: Full mix, Mixer Enables on, Local Inputs on, Volume set to 0 dB. inputs open, outputs 600 ohm terminated

Crosstalk: -85 dB typical. Conditions: No mix, Mixer Enables on, Local Inputs on,

Volume set to 0 dB. +10 dBm 1KHz. signal into any input, measure any output

-80 dB typical. Conditions: Full mix, Mixer Enables on, Local Inputs on, Volume set to 0 dB. +10 dBm 1KHz. signal into any music or page input.

Size: 19 inches wide, 14 inches high (8RU), 13 inches deep

Mounting: Standard rack mounting, usually located 55 inches above finished floor.

Wall Plates

Size: 6 1/4 inches wide by 4 1/2 inches high, approximately 2.5 inches deep
Mounting: fits standard 2 or 3 gang electrical wall box with four or 6 screws
Switches: membrane
Connector: 5 pin connector
Cable: West Penn #3651 or 3751 (see page 13 for details)

Power Supply (PSA)

Size: 3 1/2 inch high, 6 inches deep, 10 inches long (approximately)
Mounting: rear rack rail
Input power: 105 to 132 VAC, 50/60 Hz, 100 watts
Output: +15 volts, +25 volts, -25 volts nominal
Fuse: 2 amp
Switch: power on/off (lighted rocker switch)
Interconnect: 8 foot cable supplied, 5 conductor stranded
Indicators: three LED indicators, one for each of the unregulated voltages

MON Monitor/VU Panel Assembly (optional)

Monitor/VU Panel

Input: 70Volt speaker level
Size: 19 inches wide, 5 1/4 inches high(3RU), 4 1/2 inches deep overall
Mounting: standard rack rails

Monitor Relay Card (supplied with the Monitor/VU card)

Size: 3 1/4 inches wide, 9 1/2 inches long, 1 inch high, comes already mounted in a 19 inch FSR TRAC-BRAC
Mounting: rear rack rails

MLH Head Table Speaker Assembly (optional)

Head Table Breakout Card (HTBC)

Size: 3 1/4 inches wide, 2 3/4 inches long, 1/2 inch high
Power: HT-PS supply provided

Head Table Relay Card (HT-8)

Size: 3 1/4 inches wide, 7 1/4 inches long, 1 inch high, can have up to four of these cards per system
Mounting: rear rack rails, both the HTBC and the HT card come already mounted in a 19 inch FSR TRAC-BRAC

FM Facility Manager Control (optional)

Facility Managers Panel (FM-INT)

Size: an enclosed box 3 1/2 inches wide, 5 inches long, 1 1/2 inches high
Mounting: sits on the managers desk
Power: a wall mounted power supply

AUD Audio Monitor Add-on (optional)

Size: processor card(MNP); 3 1/4 inches wide, 7 inches long, 1 1/2 inches high
speaker switching card (MNRL); 3 1/4 inches wide, 9 1/2 inches long, 1 1/2 inches high

Mounting: both the MNP and the MNRL cards come already mounted in a 19 inch FSR TRAC-BRAC

Speaker: enclosed in an attractive baffle 7 inches high, 6 1/2 inches wide, 5 inches deep

R-MAP Remote Map Panel (optional)

Size: 20" wide, 14" high, 2 1/8" deep

Mounting: standard rack rails

Power: 120 VAC, via knockouts in case

R-MON Remote Monitor Panel (optional)

Size: 20" wide, 5 1/4" high, 2 1/8" deep

Mounting: standard rack rails

Power: 120 VAC, via knockouts in case

CTRL Control System Interface (optional)

Size: 8 1/2", 1 1/2" high, 4 3/4" deep

Mounting: use supplied rack mounting bracket

Power: wall wart 9 VAC

INT Map Panel Status Interface (optional) & LU Lighting Interface (optional)

Size: 7 1/2" wide, 7 1/2" high, 2 1/2" deep

Mounting: panel mount

Power: wall wart 9 VAC

AUDIO CONNECTOR WIRING

In any professional sound system with many inputs and outputs it is strongly recommended that all audio wiring be balanced. All the audio inputs and outputs on the ML-116 system are balanced.

In a balanced configuration the connectors are wired as follows:

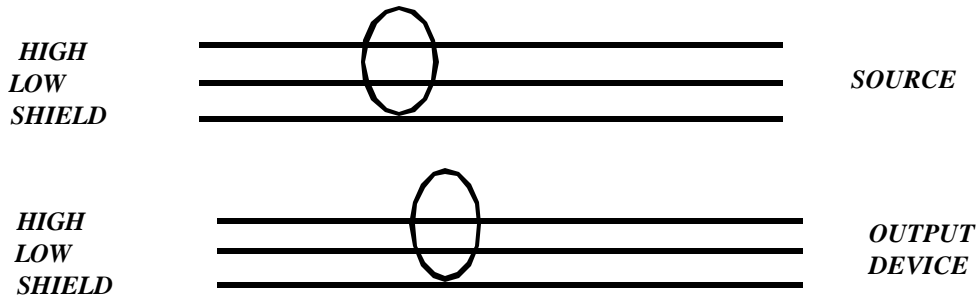

If due to some equipment limitations unbalanced wiring must be used then the proper way to wire the audio connectors follows:

Input Wiring (single wire with overal shield)

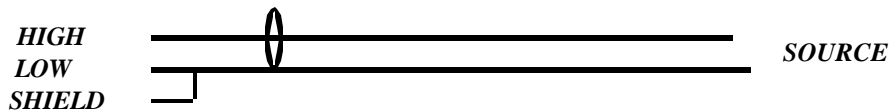

Input Wiring (two conductor overal shield)

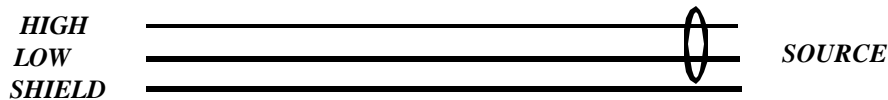

Output Wiring (single wire with overal shield)

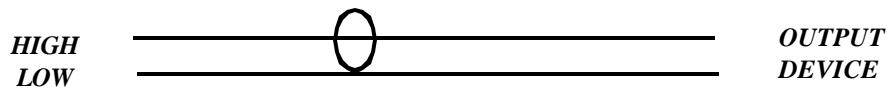

Output Wiring (two conductor with overal shield)

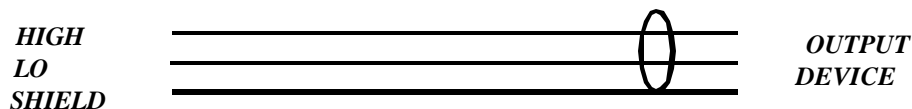

CABLING

AUDIO

All audio connections to the ACU are 3 pin connectors with pin 1 ground, pin 2 High, and pin 3 Low.

Head table speaker operation is optional and is contained on a PC board. This board mounts on a TRAC-BRAC, usually adjacent to the audio power amplifiers. There are two terminals for each speaker output and two terminals for the amplifier input. However, only one side of the line is switched. The other set of terminals are for convenience. The plug-in wall transformer powers the HTBC (head table break out card), which in turn powers the HT-8 relay cards. Up to four HT-8 cards can be implemented per system.

The monitor relay card is associated with the Monitor VU panel and provides the actual speaker switching. Both sides of the speaker line is switched. A plug-in wall transformer powers the card.

CONTROL WIRING

The following diagram illustrates the control wiring for the ML-116 system. Refer to following sections for details on head table, page, and facility manager operational hookup diagrams.

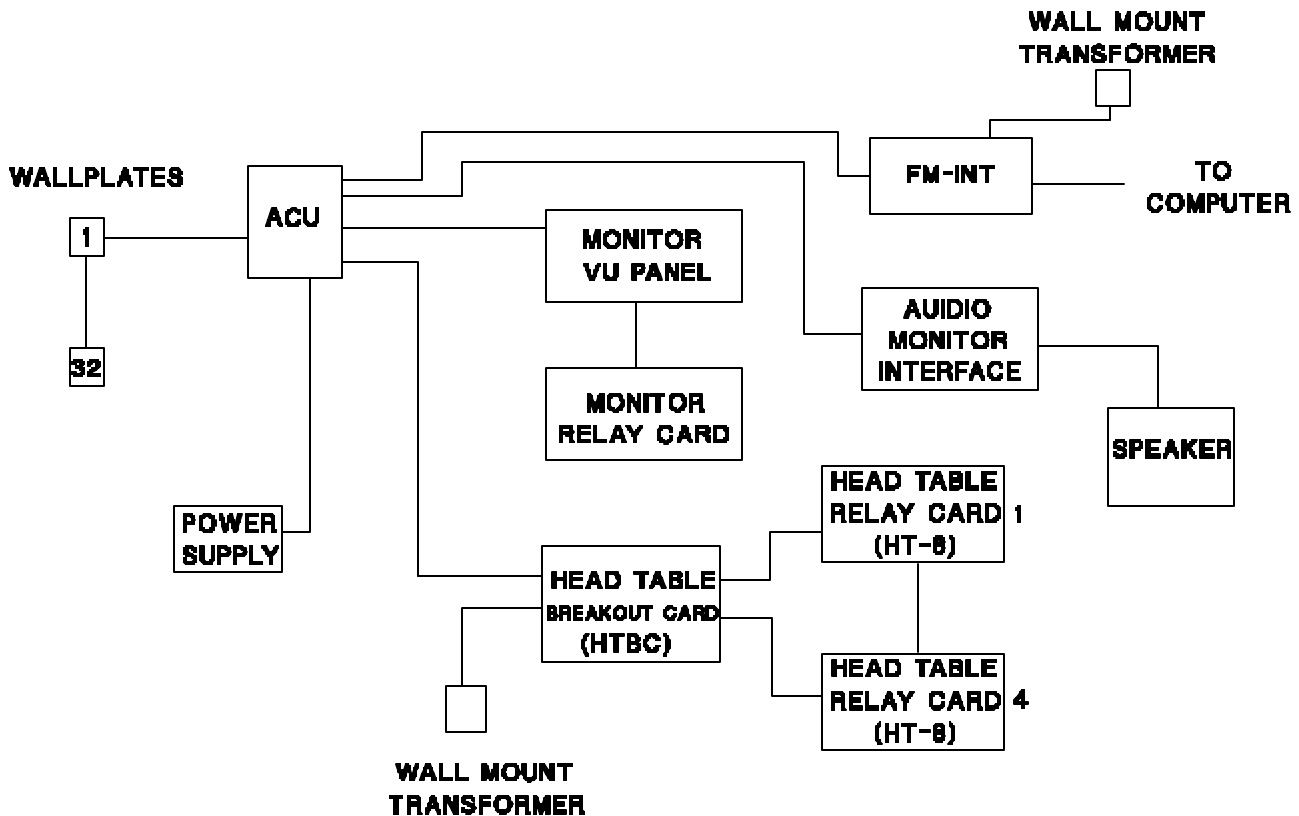

WALLPLATES

The wallplates can be wired in either a home run (star) or modified daisy chain configuration.

Use two twisted pair 22 AWG stranded, with an overall shield (West Penn # 3651) if the home run configuration is employed for each wallplate and total distance to any wallplate does not exceed 1000 feet.

Use two twisted pair 18 AWG stranded, with an overall shield (West Penn #3751) if the wallplates are daisy chained together (it is recommended to only daisy chain 6 wallplates per home run) with no more than 1000' total wire length.

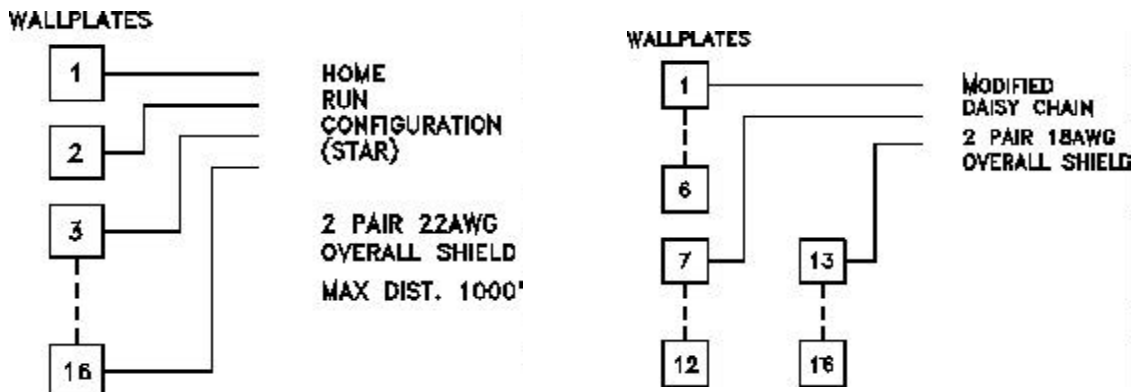

Refer to the figure for terminal identification. Four screw terminals are provided on the rear of the wallplate for cable hook-up.

REAR OF WALLPLATE

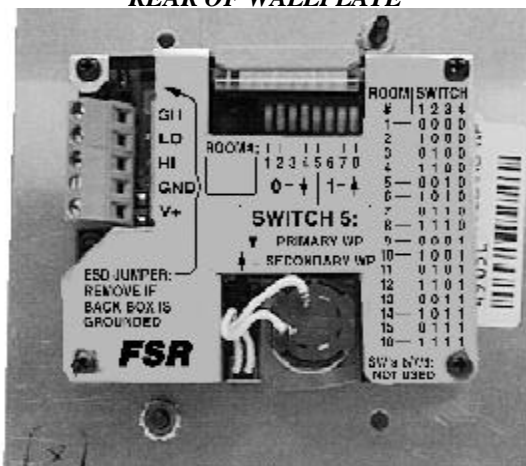

Note: it is essential that in any case the voltage on pin 1 on the wallplate connector be in excess of 8 volts DC..

TERMINAL POSTION

- 1 POWER +
- 2 POWER GROUND
- THIS IS ONE PAIR**
- 3 DATA HIGH
- 4 DATA LOW
- THIS IS ONE PAIR**
- 5 SHIELD IF USED

One is installed in each room and is wired to the ACU. The wallplates mount in a standard 2 or 3 gang electrical box. An eight position dip switch on the rear of the wallplate is used to assign the wallplate's room address. This switch is preset at the factory to the area identified on the front of the wallplate itself, but should be checked prior to installation.

The system is shipped in a default setting for all dip switches which will permit instant operation of the system in its usual configuration. Please refer to the DIP SWITCH section for details on all the dip switch functions.

SYSTEM CONFIGURATION

The ML-116 system allows the user greater flexibility than any other room combining system made today! No other system allows the user the choice of 4 music input selections, or provides the local mixer enable that greatly reduces distortion when combining rooms. The rack mounted Audio Control Unit (ACU) unit can handle up to 16 rooms and was designed to be linked together with other ACU's to control the audio in up to 128 rooms.

The basic system configuration consists of an ACU, Map Panel, Monitor Panel, Wallplates and an optional Facility Manager's Panel. Each unit of the ML-116 has its own unique responsibility and processing is distributed throughout the entire system. The responsibilities of each unit is described below:

ACU UNIT

The ACU is the rack mounted brain of the system. It contains the CPU module, one RA2 (room audio) module per 2 rooms, a Regulator module, a MP (music page input) module, and an HTP (head table and page control) module.

The CPU module is the central controller of the system. It is responsible for controlling the other modules and receives data on what to do from the Wallplates, Monitor Panel, and Map Panel and/or FM Panel. It uses dip switches (discussed in the Dip switch/Jumper section) to determine settings and operating modes.

WALLPLATES

The wallplates are microprocessor controlled modules that are used for room audio control. They are responsible for setting Local Input on/off, Music on/off, Music Selection, Local Input Volume, Music Volume, and Local Mixer Enable on/off. The Section on Dip Switches describes the settings used on the wallplates and those on the CPU module that set modes on the wallplates.

MAP PANEL & REMOTE MAP PANEL

The Map Panel is responsible for controlling the system setup by mixing rooms together and selecting head table locations. It is microcontroller based and communicates to the CPU module. The map panel is fabricated at the factory and is not configurable on site.

MONITOR PANEL & REMOTE MONITOR PANEL

The monitor panel is also a microprocessor controlled module placed near the ACU unit which allows the user to 'monitor' the settings in a room. The user can adjust those settings by using the monitor panel's built in 'wallplate'.

FACILITY MANAGER'S SOFTWARE PANEL, including the FM-INT Unit

This is a software program that runs on a PC and controls the system by imitating the Map Panel and has the ability to combine rooms without mix switches. It is customized and is not configurable. It communicates over two twisted pairs to the ACU using a multidrop proprietary protocol. The FM-INT Unit interfaces this line to the computer. An enclosed audio speaker would also be used if the audio feed was implemented.

DIP SWITCH / JUMPER SETTINGS

ACU Audio Control Unit, CPU Module

The CPU Module contains sixteen (16) dip switches which will allow users to customize the system to a large degree. These switches in addition to two jumpers on each room audio (RA) module, allow the user to select such options as simultaneous microphone and music operation, key switch interlock functions, ramp speed, etc. The definition of the switches are as follows:

Dip switch	Factory Setting	Explanation
1	open	Memory Volume
2	open	Preset Volume
3	open	Reserved
4	open	Enable Mode
5	open	[Wall Plate
6	open	Interlock Mode]
7	open	Reserved
8	closed	Cold Start Select
9	open	Select multiple Systems
10	open	Select multiple Systems
11	open	Select multiple Systems
12	open	Select multiple Systems
13	open	Reserved
14	open	If Monitor Panel Present
15	open	If FMP present
16	open	If Map Panel Present

Dip switch 1 - Initial Volume Memory Option - closed the volume is determined by the dipswitch 2 setting, if open the volume is restored to level that was last set.

Dip switch 2 - Preset Volume - Setting determines the power up default volume level, if closed the volume initializes to -12 db, if open it initializes to 0 db.

Dip switch 3 - Reserved

Dip switch 4 - This dip switch allows simultaneous operation of voice and music. If the dip switch is open then the system is in normal mode, the voice and music are exclusive. This is commonly referred to as the pre-enable mode. If the dip switch is closed, both voice and music can be operated at the same time (simultaneous mode). The system is shipped with this dip switch in the open position.

Dip switch 5 and 6 - Wallplate Interlock Mode.

If Switch 5 is closed, the wallplate keyswitch has no effect on the operation of the wallplate. The local input and music sections of the wallplate are always active. In this position Switch 6 is not used.

If Switch 5 is open and Switch 6 is open, the 'partial interlock' mode is selected. This is the default mode for the ML-116. In this mode, the keyswitch interlocks only the microphone section of the wallplate.

If Switch 5 is open and Switch 6 is closed, the 'full interlock' mode is selected. In this mode, the wallplate cannot be operated without the keyswitch.

Dip switch 7 - Reserved

Dip switch 8 - System Clear When system power is removed the ML-116 has the capability to save the state of the system including the combining status of all the rooms and the state of each room's local input and music selectors and volume. If open, the ML-116 saves its states, if closed it initializes to a "clear" state.

Dip switches 9 to 12 are used to address multiple ACU's. The coding is as follows:

<u>12 11 10 9</u>		<u>12 11 10 9</u>	
O O O O	-	C O O O	ACU 1
O O O C	-	C O O C	ACU 9
O O C O	-	C O C O	ACU 10
O O C C	-	C O C C	ACU 11
O C O O	-	C C O O	ACU 12
O C O C	-	C C O C	ACU 13
O C C O	-	C C C O	ACU 14
O C C C	-	C C C C	ACU 15
			ACU 16

Note: C=dip switch is closed, O= dip switch is open

These switches would only be used with a Facility Managers Panel and multiple ML-116 systems.

Dip Switch 13 - Reserved

Dip Switch 14 - Monitor Panel Present (switch open)

Dip Switch 15 - Facility Manager's Panel Present (switch open)

Dip Switch 16 - Map Panel Present (switch open)

Room Audio (RA2) Card Jumper Settings

The ML-116 RA2 cards contain two jumper fields to allow page mode configuration. The jumpers determine whether or not "Normal Paging" occurs during Mic or Music functions. A four position jumper field is provided for each room. Each bank of jumpers is clearly labeled as either "Low Room" or "High Room". Within a bank of jumpers, one pair is labeled "Page Thru Music" and the other pair "Page Thru Mic". Within a pair of jumpers, one jumper is labeled "Y" for yes, and the other "N" for no.

The system is factory configured to allow Normal Mode Paging during music but not while mics are enabled (Page Thru Mic = Y; Page Thru Music = N). You may reconfigure the system to operate as required on a room by room basis. For example, to allow Normal Mode Paging to occur during Mic and Music, set both the Page Thru Mic and the Page Thru Music jumpers to Y. In most cases, all rooms within a system should be configured with the same jumper settings to ensure consistent page operation.

In certain cases, it may be desirable to set the page jumpers differently for different rooms. An example of this would be when a single ML-116 system is used to control two different ballrooms or a single ballroom with a surrounding corridor.

WALLPLATES

The wallplates used in the ML-116 system are membrane. They control all wallplate functions. These functions include Music Selection, Local Mixer, Music Enable and Volume, and Microphone Enable and Volume.

When the wallplates sense a key press it waits for a poll from the ACU then it sends a message to the ACU which will return an update message. The wallplates will then check for another keypress and repeat. Internal flags will prevent the wallplates from acting on the same keypress until the update message is returned. This whole process occurs within a fraction of a second.

The wallplates communicate with the ACU over a RS-422 line and are addressable. This address is a 5 bit address (0-31) allowing the use of up to two (2) wallplates per room.

Membrane Wallplate Dip Switch Settings

The ML-116 allows for up to 32 wallplates: 2 per room up to 16 rooms. The wallplates must be individually addressed. The addresses are set by setting the dip switches on the back of the wallplate. The address is a binary code representing the room number minus one, given on switches 1 through 4 with a closure representing a 1.

SWITCH	1	2	3	4	SWITCH	1	2	3	4
ROOM 1	0	0	0	0	ROOM 9	0	0	0	1
ROOM 2	1	0	0	0	ROOM 10	1	0	0	1
ROOM 3	0	1	0	0	ROOM 11	0	1	0	1
ROOM 4	1	1	0	0	ROOM 12	1	1	0	1
ROOM 5	0	0	1	0	ROOM 13	0	0	1	1
ROOM 6	1	0	1	0	ROOM 14	1	0	1	1
ROOM 7	0	1	1	0	ROOM 15	0	1	1	1
ROOM 8	1	1	1	0	ROOM 16	1	1	1	1

*Note: 0= switch open
1= switch closed*

Switch 5 is used for rooms with two wallplates. In a two wallplate room, one and only one of the wallplates (it does not matter which one) should have switch five closed.

Switches 6 through 8 are used for factory self tests and should be open for normal use.

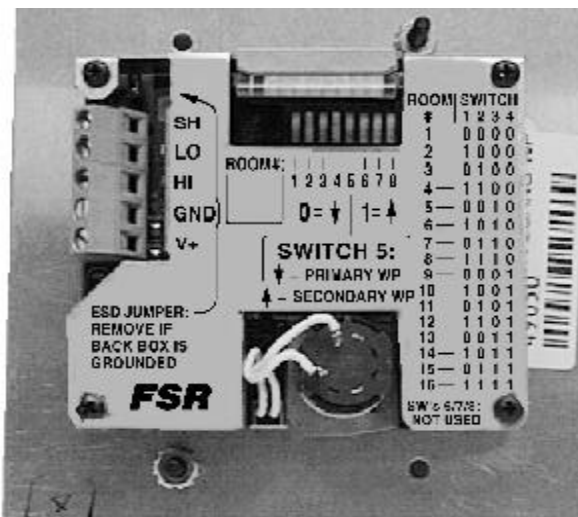

SWITCH POSITIONS

*1-5 ADDRESS
6-8 FACTORY USE ONLY*

Picture of rear of wallplate

Wall Plate Functions

All wallplates will handle these functions in the same way.

Speech/Audio

Alternating action switch that enables/disables audio from any selected mixers within a mixed group. “Pre-selects” audio from any selected mixers in a mixed group when music is playing.

Local Mixer

Alternating action switch that enables/disables audio from the mixer associated with a given area to be heard in the entire mixed group. The switch remains independent of the corresponding switch on other panels within a mixed group. This switch tracks with local input in a single room and will automatically turn on in the first room in a mixed group to enable local input.

Music

Alternating action switch that activates selected music source within each room or a mixed group of rooms.

Music Select 1-4

Selects the music source within each room or a mixed group of rooms.

Up/Down Volume (Speech)

Ramps volume up/down within each room or a mixed group of rooms. Associated bar graph indicates level and is active only when local input is audible. All bar graphs within a mixed group will track together.

Up/Down Volume (Music)

Ramps volume up/down within each room or a mixed group of rooms. Associated bar graph indicates level and is active only when Music is enabled. All bar graphs within a mixed group track together.

Keyswitch

Interlocks (disables) certain groups of switches on the wall plate as determined by the selected option jumpers.

MAP PANEL

The ACU may have a Map Panel that will control the combining of rooms. Every system has a unique panel layout reflecting the actual layout of the rooms. The Interlock button on the Map Panel is used to enable all switches on the map panel, while preventing accidental mixing or unmixing. The ACU will take the rooms that are combined and form a group entry for those rooms. This means that all the wallplates in those grouped rooms will act identically and all the group's mix LED's will be on.

The normal operation of the Map Panel is to combine rooms that are adjacent to one another or have a common wall. On special order, the Map Panel can be set up to mix one room to a non adjacent group but needs to be defined prior to design. The user would have to know that they wanted that capability and make that known to FSR when the Map Panel is submitted for sign off.

LEDs are used to indicate Speech or Music, Head Table Switch enabled, and which rooms are combined. The LEDs used for combining will automatically be lit if the combining of rooms included on the switch is included in a group.

Sample layout of map panel

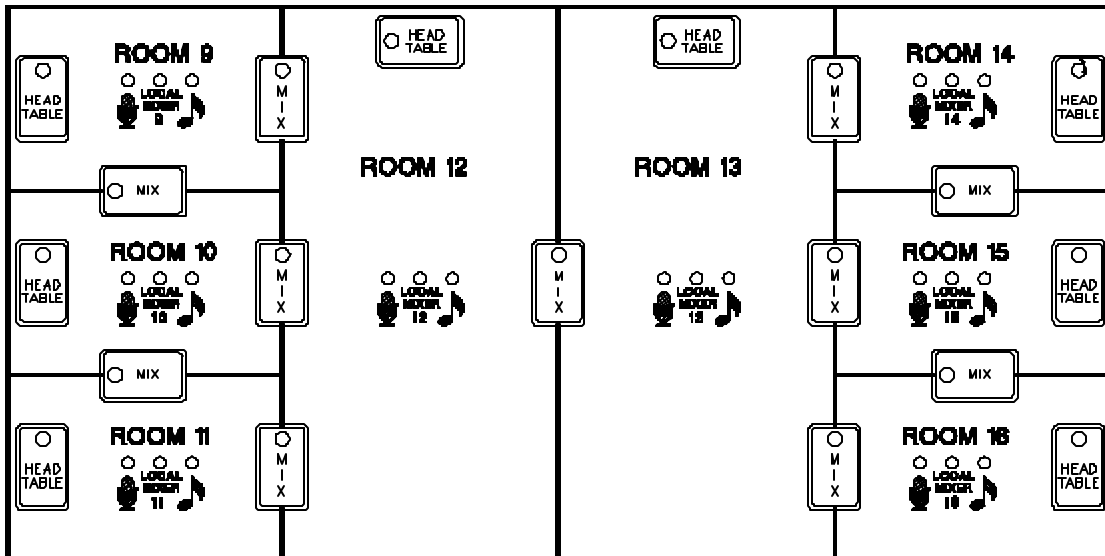
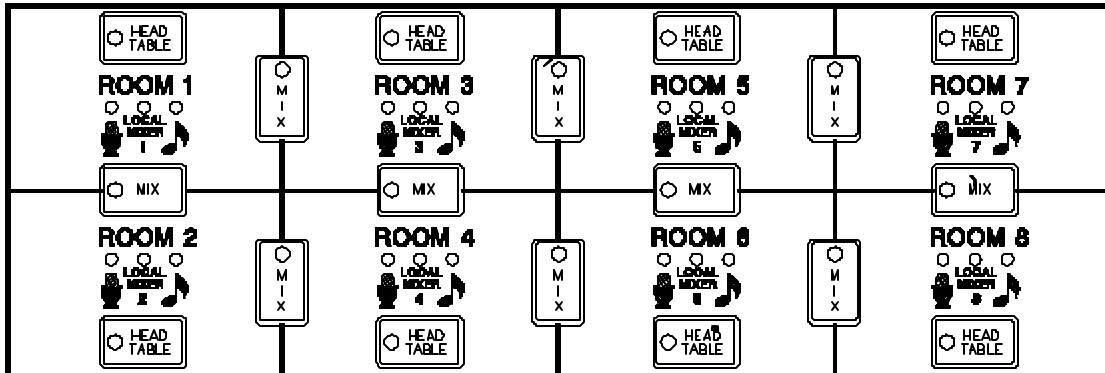

○ MAP PANEL LOCKOUT



MAP PANEL (continued)

Explanation of MAP switch controls:

INTERLOCK SWITCH

This switch must be depressed (operated) in order to operate any switch on the MAP panel. It prevents accidental operation.

MIX SWITCH

When any MIX switch is operated the associated LED illuminates indicating that those two areas (rooms) are joined. In joining many rooms into one setup just keep operating the appropriate MIX switches until the group is complete. To break apart a group of rooms just operate any of that groups' MIX switches and the whole group will disband.

HEAD TABLE SWITCH

This switch, when operated, will cutout the speakers over that location whenever the mic's are active and will reinstate those same speakers whenever the mic is preselected or off. This the same as saying that the speakers are active when music is playing but shift to inactive when the mic is active. This switch cannot be deactivated when the microphones are on.

Explanation of MAP LED operation:

MIX SWITCH LED's

These amber LED's illuminate when the two adjacent areas (rooms) are mixed.

HEAD TABLE LED's

These red LED's illuminate to indicate that the head table in that area(s) has been selected.

MICROPHONE LED's

These red LED's illuminate whenever a microphone (mixer) is either selected or is active.

LM (local mixer) LED's

These green LED's illuminate whenever the LM is selected or, in the case when the room is unmixed it will automatically be illuminated since that mixer will be active.

MUSIC LED's

These green LED's illuminate whenever the music input is active (music is playing in the room).

MAP PANEL LOCKOUT LED

When this red LED illuminates it locks out the map panel. This will only happen if the Facility Manager option is in place and it commanded a non-adjacent room be added to a group.

ADJUSTMENTS

As with any high performance audio system, proper adjustment is key to achieving optimum S/N (signal to noise) ratio and performance characteristics.

Once the system is fully assembled including the mixers, amplifiers and other audio processing equipment, you may begin.

In order to properly calibrate the system, you will need a signal source capable of providing a mic and line level signal. You will also need a VTVM or other instrument that can measure voltages, preferably with a dBm scale.

Begin by injecting a 1 Khz. typical mic level signal into a mic input of the Room One mixer. Monitor the output of the mixer using the VTVM while adjusting the mixer channel and main out controls to achieve a 0 dBm level. The mixer controls should not be set to their extreme settings for best performance. Mark the settings so that users may re-establish them after changes are made. Continue by moving the input signal to each of the mixers mic input channels, and calibrating them in turn.

CAUTION: At no time in the following procedure should you change levels by adjusting the volume up down switches at the Wallplates or ML-116 Monitor Panel. Doing so will invalidate your calibrations resulting in a lot of wasted time.

If you should accidentally alter the volume settings, reset the system to a known state by turning the power off and on, and reselecting the desired settings.

Next , using the ML116 Monitor Panel or Room Control Panel, set Room One to Local Mixer on, Mics On. The Mic volume bar graph should illuminate the third led from the top. If not, consult the dip switch setting section of this manual to reset the factory settings. Check the output level of Room One's audio card to confirm unity gain through the ML-116 system. Proceed to the output of each successive audio component in Room One's audio chain, adjusting as necessary to achieve 0 dBm. Stop at the power amplifier input.

Move the signal source to the first mic input of the next mixer, and repeat the procedure for Room Two. Continue in this manner until all rooms are complete.

Continue by setting Room One's wallplate to Music On, Mic and Local Mixer Off. Select music source one. The Music volume bar graph should illuminate the third led from the top. Inject the anticipated nominal music level into Music Input Source 1. Adjust the associated gain trim pot (just below the input connector) to yield 0 dBm at the output of the ML-116 audio card. Select the next music source and repeat this procedure until all four busses are calibrated.

If the paging feature of the system is to be used, inject the anticipated level page signal into the page input connector. Ground the Priority Page and All Call terminals of the page control terminal block. Adjust the page gain trim pot to obtain 0 dBm at the output of the ML-116 audio card.

At this point, the entire system is calibrated, with the exception of the power amplifier gain setting. To set the power amplifier gain, you will require some equipment to measure SPL in the room area. Begin by mixing all room areas together, and opening all divisible meeting areas. If your system consists of several nonmixable subsections, mix all rooms that are possible.

Set all area wallplates to Music On, Mic Off. Inject the anticipated level signal into the Music Source One input bus. Using the SPL measuring instrument, monitor each room and adjust each power amplifier as necessary to achieve a uniform level throughout all areas.

Keep in mind that the ML-116 system will allow volume adjustment of +4 to -18 dB with respect to unity, so you will want to adjust the amps close to the maximum desired level during this procedure.

The adjustment procedure is now complete.

PAGING SYSTEM OPERATION

The ML-116 system supports the integration of a new or existing paging system. A Page Audio input, Page Control Room Selects, and Normal/Priority mode page selects are provided for interface to the system. Option jumpers on each audio card determine under what conditions normal mode page audio will be heard in the rooms.

The actual paging operation of a particular system will depend upon how paging was implemented by the audio system design engineer/installing contractor.

The system supports two primary paging modes; Normal Paging and Priority Paging. During a Priority mode page, the room audio will be muted and the page audio will be unconditionally switched into the selected rooms, regardless of room wallplate settings. The page audio level is controlled only by the pre-configured amplifier gain settings, and page input level adjust control on the ML-116 ACU. Any selected audio (Mics and/or Music playing in the selected rooms) will be disabled for the duration of the page. **Caution should be used when selecting Priority mode paging to guard against interrupting any meetings in progress.**

During a Normal mode page, page audio will be switched into the selected rooms based on the current wallplate settings in conjunction with the page configuration jumper settings. As shipped from the factory, Normal paging will occur during music operation, but will be automatically disabled if Mic audio is enabled in the selected room. During a Normal page, page audio will be mixed with any selected audio in the room (Music only, based on factory settings). The page audio level is controlled only by the pre-configured amplifier gain settings, and page input level adjust control on the ML-116 ACU. As with the Priority mode paging, page volume level does not depend upon wallplate volume settings.

Users are encouraged to consult with their installing contractor to configure the ML-116 system paging options so as to optimize the operation of a particular installation.

To initiate paging, select the desired rooms to be paged. Select the desired page mode, Normal or Priority, and speak into the microphone. Page audio does not go through until both room and page mode selections are made. To end paging, deselect page mode first, and then deselect rooms.

Typical Hookup Diagram

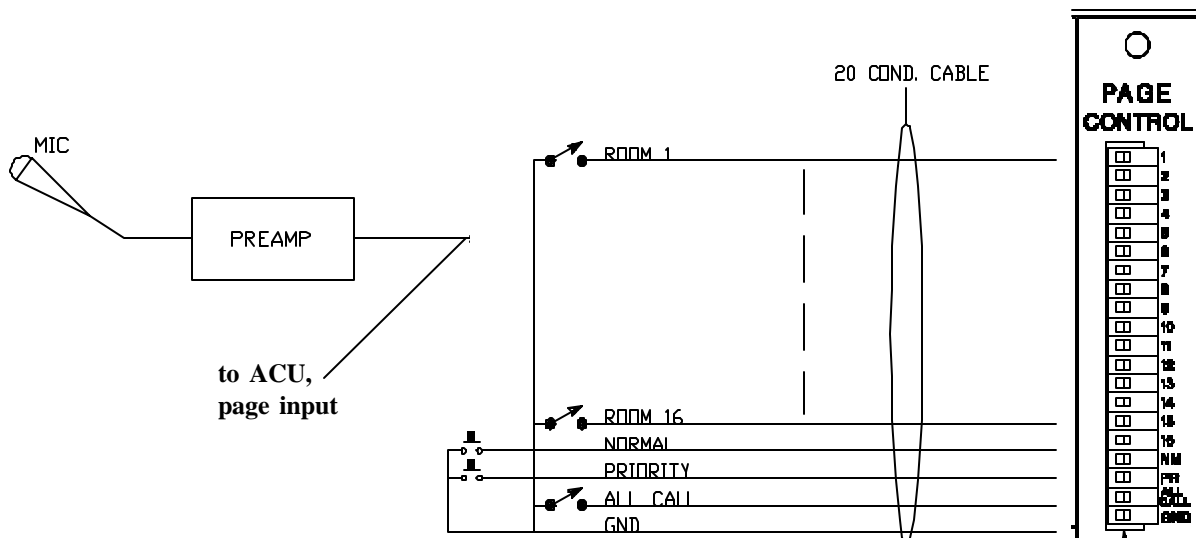

partial view of the HTP module in the ACU

USING PRIORITY PAGE AS AN “ALL MUTE” FUNCTION:

Create a short from the “ALL CALL” and “PRIORITY” terminals to the “GND” on the HTP card through the relay **maintained** NO contacts on the external control system. system.

Without page audio input present on the MP card input terminals, the mike and music audio will be muted for the duration of the relay closure.

HEAD TABLE OPERATION

The head table switches on the MAP panel control relays that switch speakers located over a head table location, on or off. When the head table switch is activated those aforementioned speakers are disconnected whenever the microphone is in use, to eliminate audio feedback, and are connected in all other modes of operation.

The installation of the head table controls requires the HTBC card along with the associated HT-8 cards be located in the rear of the rack housing the power amplifiers. Each HT-8 module contains relays for eight head table locations. The ML-116 system has provisions to handle up to 32 head table positions meaning an installation could have up to 4 HT-8 modules. All these modules come mounted in an FSR TRAC-BRAC which facilitates rear rack mounting.

All the interconnect cables from the ML-116 ACU to the HTBC and from the HTBC to the HT-8 cards are supplied with the system.

Head Table Hookup Diagram (only one HT-8 is shown, there could be a total of 4)

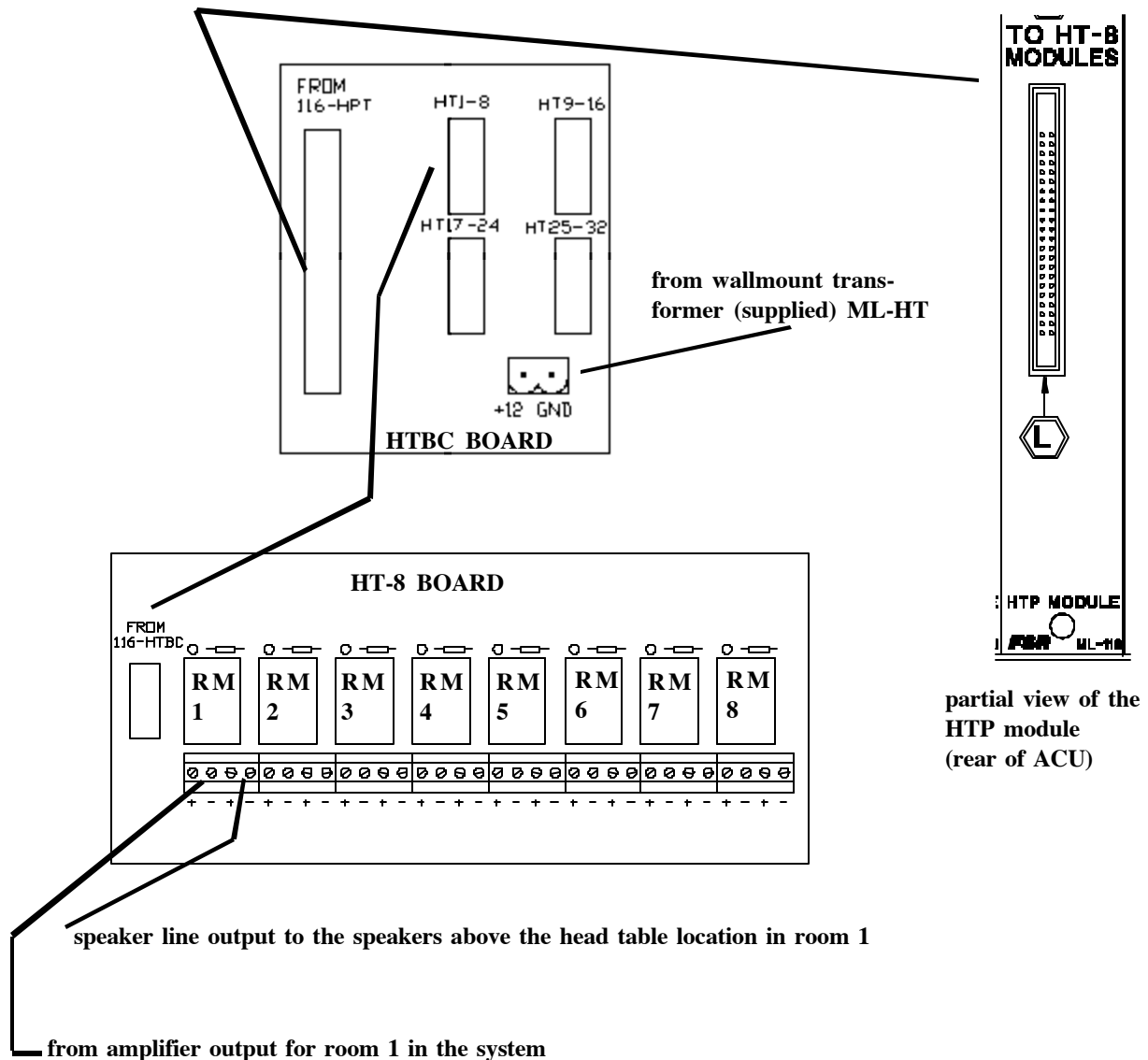

FACILITY MANAGERS PANEL

The Facility Managers Panel (FMP) is a Windows based program that performs all the same functions as the Map Panel and adds additional capability. **The most important of which is the ability to mix nonadjacent rooms.** The display of the FMP is a bit mapped image of what the Map Panel looks (or would look) like. It can take the place of the Map Panel and can perform the functions of the wallplates.

When the FMP starts it requests status from the ACU. The ACU responds with group information if any. The ACU will update the group information if a Map Panel is present and has defined a group. The FMP uses the group information to update the Windows display to reflect those rooms that have been selected into groups.

FMP Installation

To install the FMP a cable is run from the ML-116 ACU to the manager's office. This cable is two twisted pairs with an overall shield and they connect to the CPU module at the ACU. In the managers office the cable terminates in the FM-INT unit which in turn plugs into com port 1 or 2. If the audio option was ordered then another cable, specifically a standard audio line (one twisted pair with an overall shield) would also be run. It connects from the left-most terminals on the Monitor Relay Card and terminates in the speaker enclosure mounted in the manager's office.

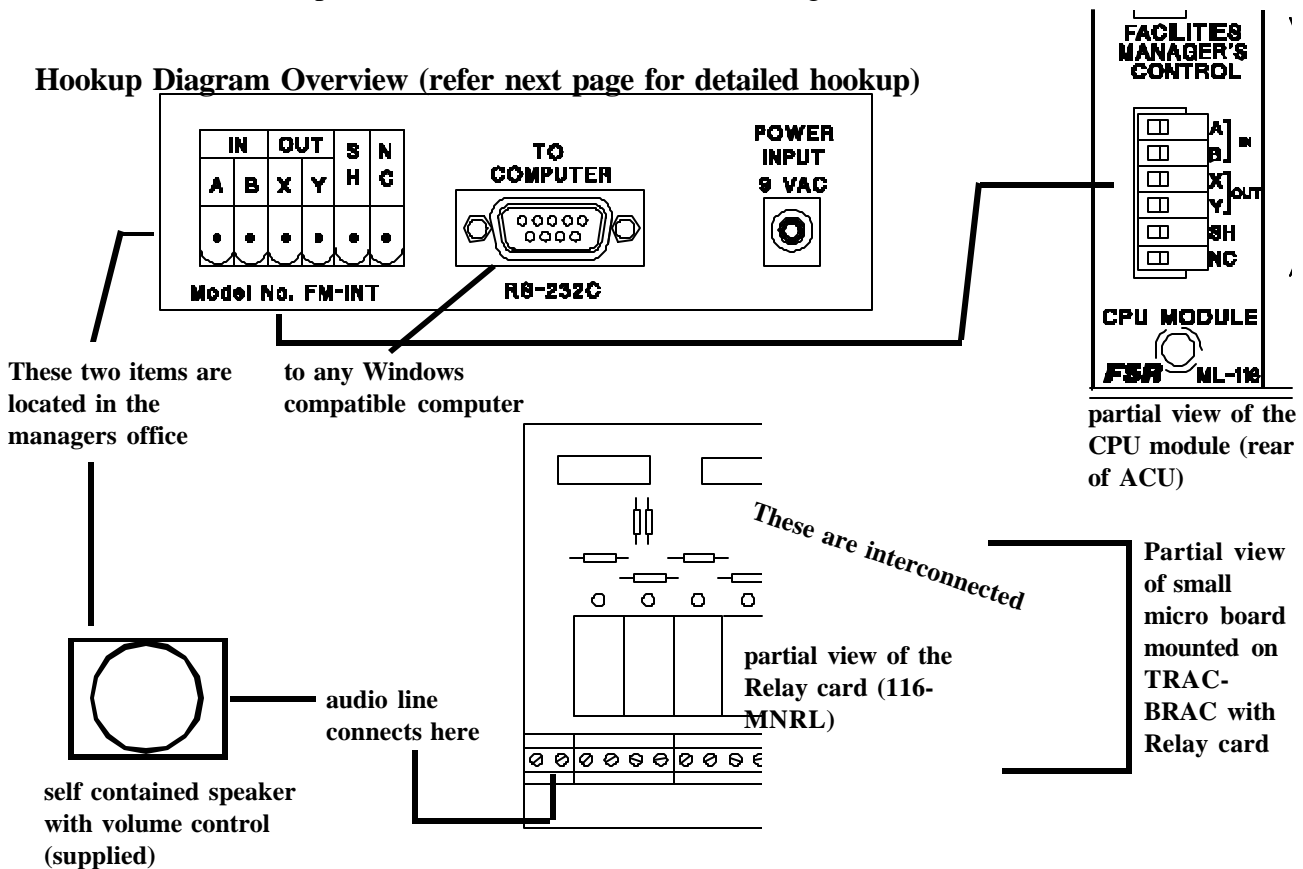

Facility Managers Panel Hookup Diagram (including the optional audio feed)

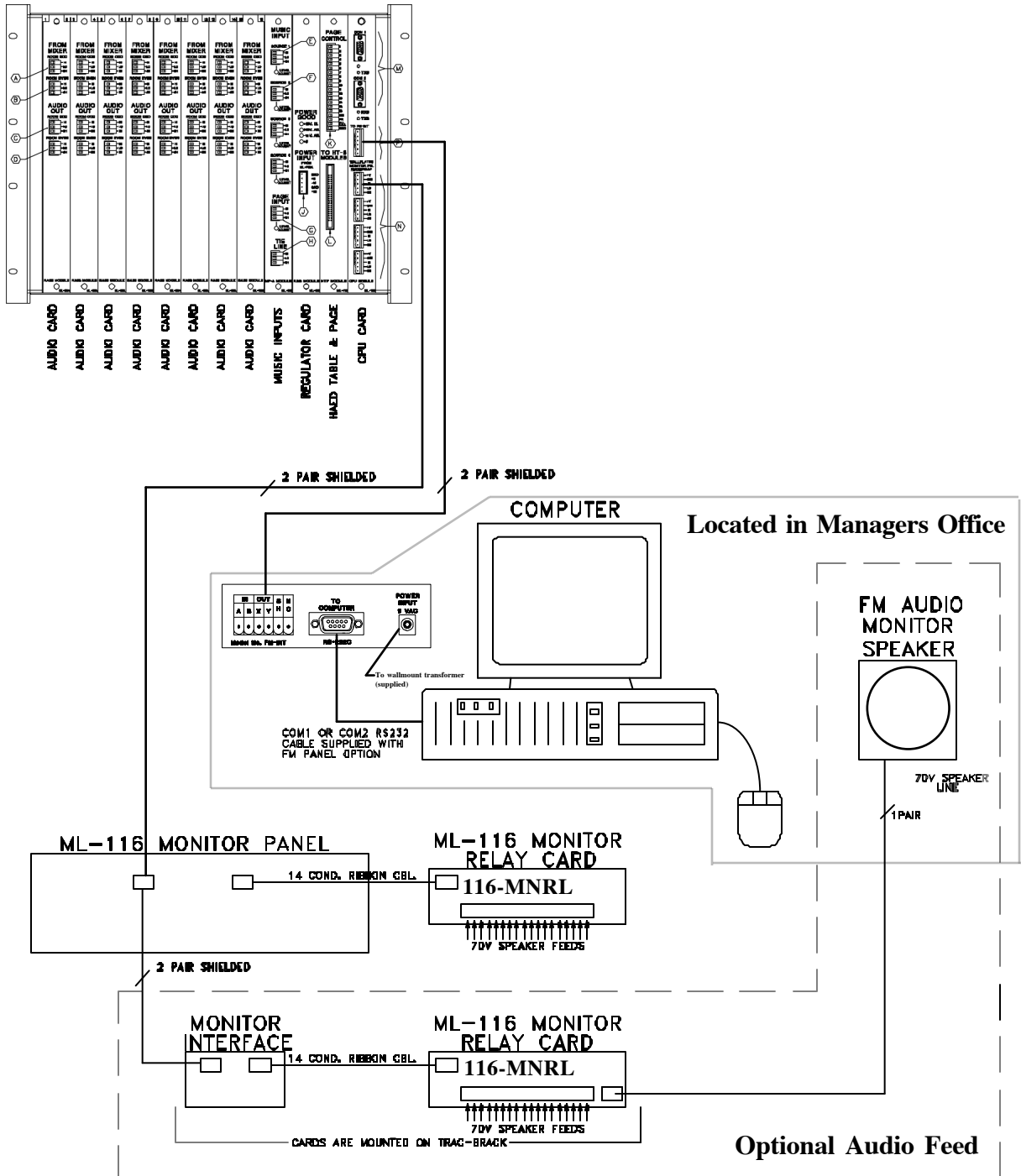

Group Functions

The FMP group functions include defining groups, adding rooms to groups, and removing groups. These functions are similar to the Map Panel except that instead of using the Interlock switch and push button the user uses a mouse.

Groups are defined as rooms that are combined to become a larger room. The rooms in the group share the same levels, music selection, and other settings. A significant advantage when using the FMP is the ability to combine nonadjacent rooms.

Rules applicable to the combining of rooms

The default wallplate settings for all the rooms in a group follow four levels of precedence:

1. If a microphone is active (local input on) that has highest priority.
2. If a microphone is selected but not yet active (local input selected) that is the next priority.
3. If music is active that is the next lower priority.
4. If nothing is selected that is the lowest priority.

Combining rooms rely on a set of possibilities and priorities. The possible combinations are combining a single room to a single room, adding a single room to a group, and combining two groups. The priorities in descending order are **Local Input On, Pre-enable On, Music On, and Nothing On**. When combining two single rooms the settings in each room is checked against the priorities and the room with a lower priority setting takes on the settings of the other room. When combining two groups the group with the lower priority takes on the settings of the group with the higher priority. When combining rooms or groups of equal priority, the room volume is reset to the default level as determined by dipswitch 2.

Some other rules applicable to the grouping of rooms are:

- Any group that cannot be directly represented on the Map panel cannot be affected (mixed or unmixed) by the Map panel.
- In a TieLine group the Head Table and Local Mixer switches are operable in the rooms on the originator unit only.
- Wallplate volume level changes affect only the rooms in the group on that ACU.
- All Local Mixer and Head Table switched on the non-originator units will be locked off.

Wallplate Status

The user has the ability to review the settings of a wallplate in any room. The user will double click on the room which causes the FMP to request the data from the ACU. The user will then be able to view and hear (if remote audio monitor was ordered) the selections on the wallplate.

MULTIPLE ACUs

In order to control more than 16 rooms the ML-116 has the ability to create groups that overlap ACUs. The ACU has a TieLine Bus which will, depending on switch settings, allow the unit to send to, or receive output from a room not present on that unit. This feature is an option and available only on systems with a FMP (Facility Managers Panel).

The user who wishes to combine multiple ML-116 Systems would have to assign the groups on each ACU (Audio Control Unit). The user selects the room to be used as the source, then the room on the other unit to be considered the destination. The output from the source will be sent via the TieLine to the destination room. The FMP will send update messages to both ACUs and will automatically configure the wallplates effected by the TieLine. Wallplates on the destination room will be set to mics on, music off to enable the use of the TieLine.

The example illustrated on the next page shows the FMP connected to 2 ACUs. The object is to define a group containing ACU#1 Rooms 1 and 2 plus ACU#2 Rooms 1 and 2. The FMP would send a Group message to both ACUs listing ACU#1 Room 1 first making it the source room, then ACU#1 Room 2, then ACU#2 Room 1 making it the destination room, and finally ACU#2 Room 2.

The source room is the room that feeds the TieLine. The destination room uses the TieLine for input. There can be only one source which means that if there was an ACU#3 added to this group ACU#2 would use Room 1 as the source for ACU#3 and so on. The first Room listed on ACU#3 would become the destination as well as the source if an ACU#4 were added.

Diagram illustrating multiple ACUs

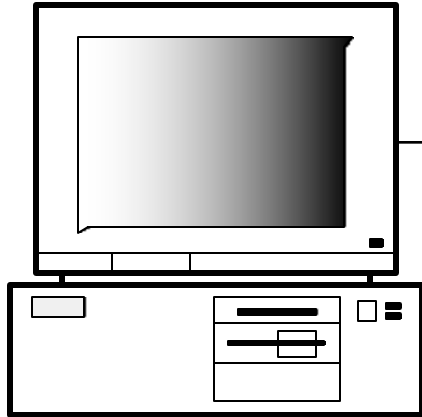

ML-116 ACU #1

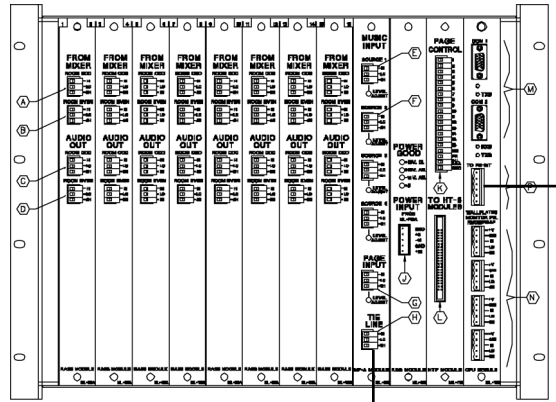

ML-116 ACU #2

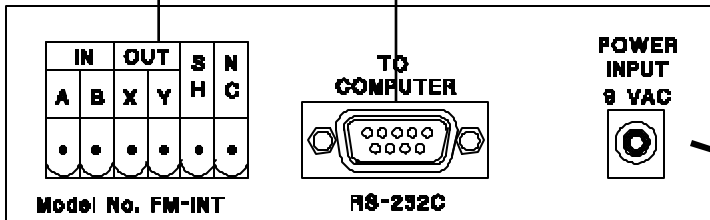
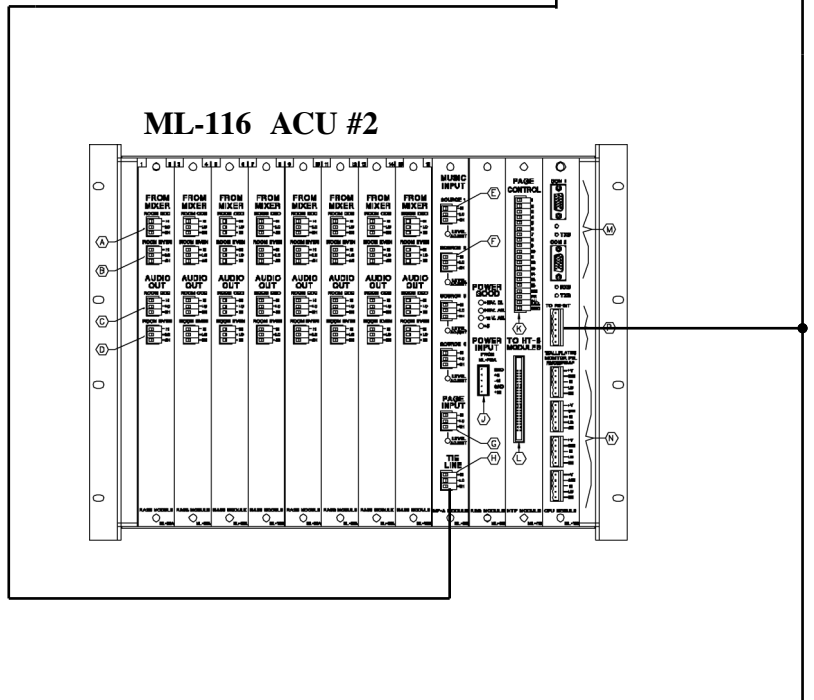

To wallmount transformer (supplied)

Hookup Diagram for Multiple ML-116 systems (includes optional Monitor/VU Panel and remote audio feed)

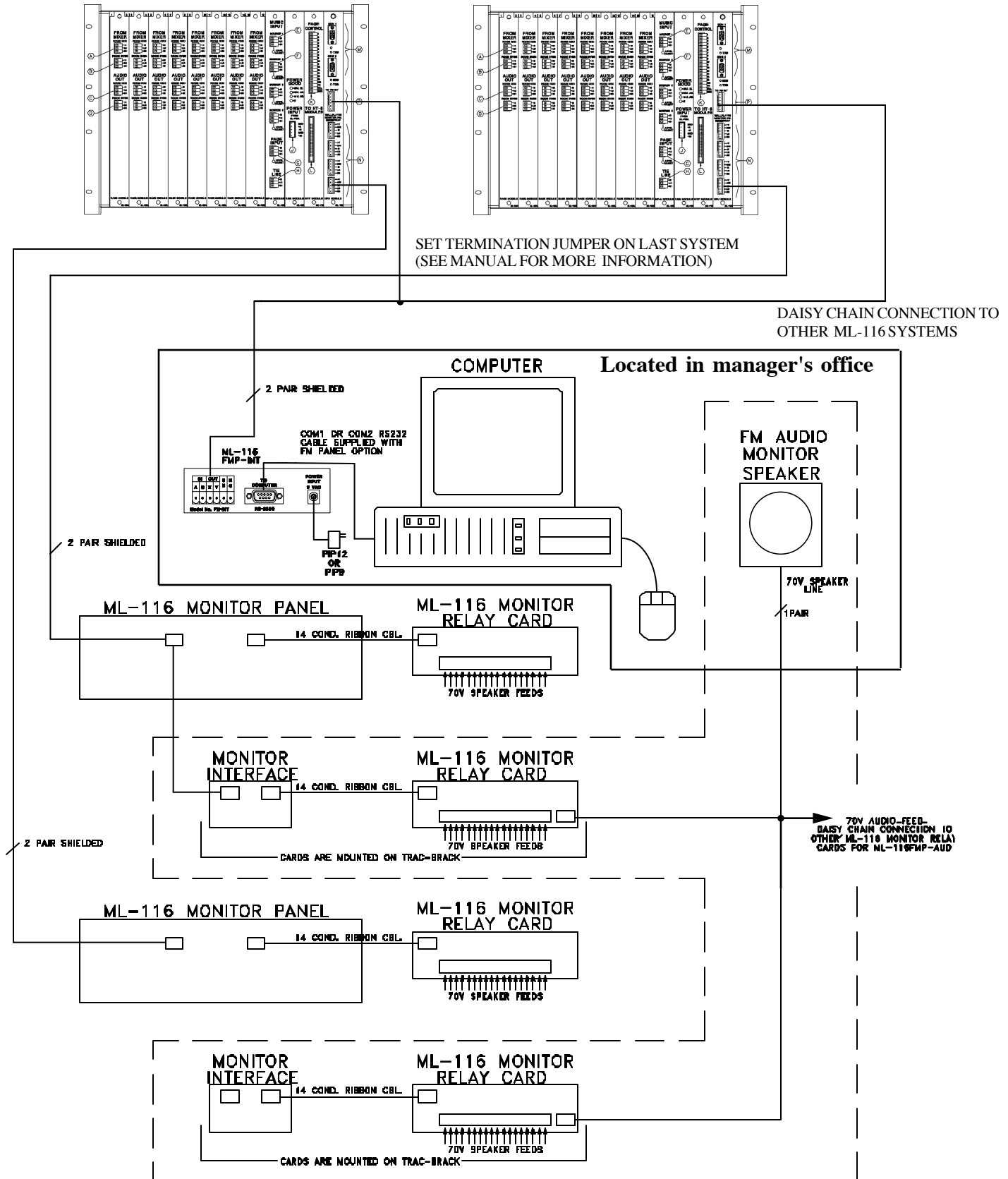

REMOTE MAP AND MONITOR PANELS

R-MAP and R-MONITOR

This accessory permits full operation of the ML-116 system from a location other than the rack area. Typically it would be mounted in a service corridor near the rooms of interest. Usually both the map and monitor panel are used however the unit will operate without the monitor panel if cost is a major consideration.

Following below is the installation information for these panels.

REMOTE MAP/MONITOR TO ML-116A SYSTEM HOOK UP

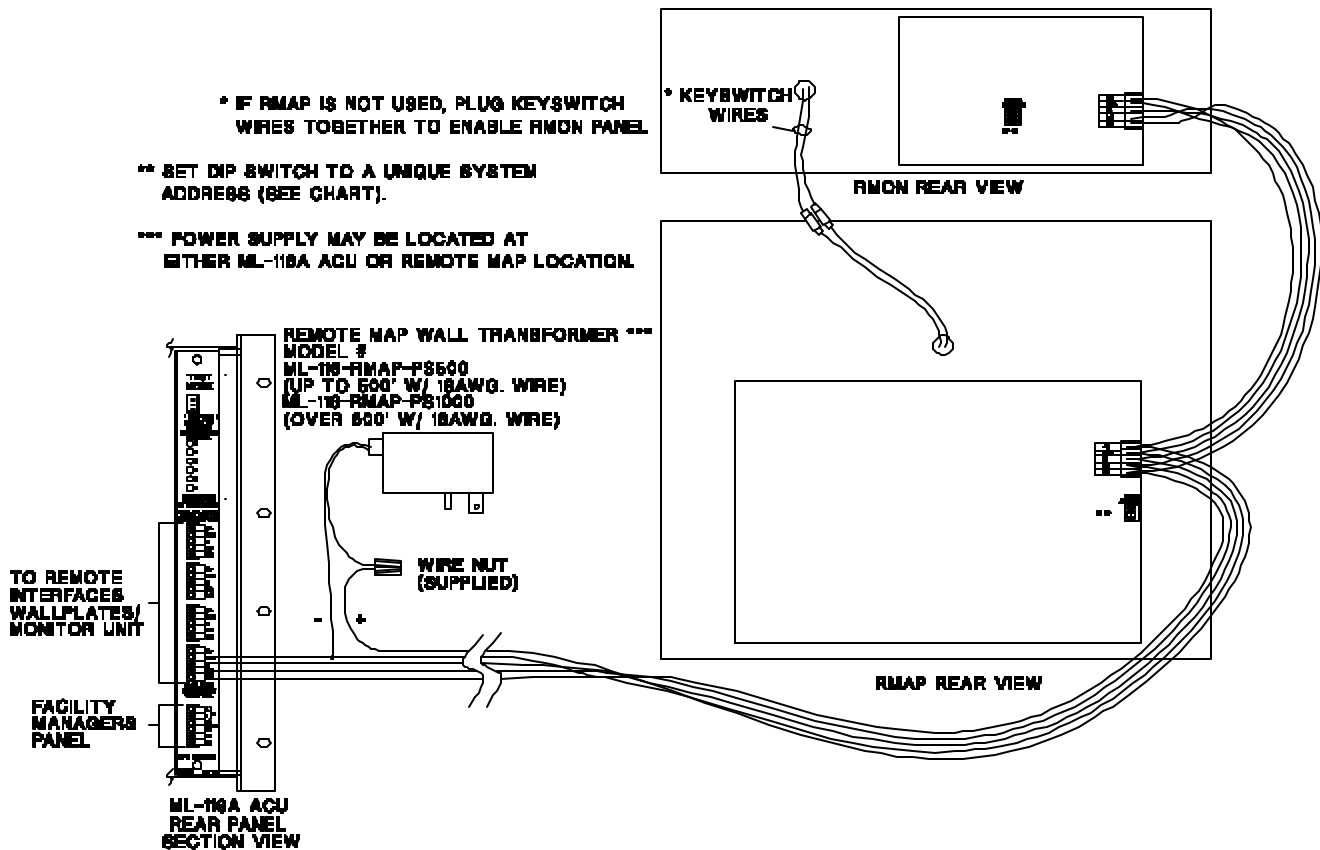

Sound system/Lighting control system integration

Now it is possible to have the lighting follow the audio output Mix and Head Table Lamp Status from the ML-116 room combining system. The addition of the ML-116-LU option interfaces LUTRON® lighting to the ML-116 room combining system permitting lighting to follow audio using one integrated wallplate.

The ML-116-LU option for the ML-116 system consists of a ML-116-INT unit and a special wallplate designed to fit in a four gang plastic trim kit provided by LUTRON®. This four gang kit mounts 1 LUTRON® controller and 1 FSR wallplate. The ML-116-INT unit receives RS-485 serial data from the ML-116 system,

processes it and opto-couples electronic closures to properly operate the LUTRON® lighting system. The data transmitted consists of mix switch status and head table status.

INSTALLATION

Equipment Areas

The sound system and lighting control system for the meeting rooms/ballroom shall be coordinated at the wallstation and via the sound system's room combining control.

The integration of the lighting control system to the sound system combining panel, FSR model number 'ACU', shall be via contact closures. The integration shall allow the lighting controls to be combined/separated based on the status of the partitions on the 'ACU' panel, which is providing the same function for the audio controls.

The electrical contractor shall be responsible for the mounting of the ML-116-INT interface unit and wiring to the lighting control system. The sound contractor shall be responsible for the wiring between the ML-116-INT, and the 'ACU' panel as well as the system setup to ensure proper operation. Usually there will be a LUTRON® representative present to review the entire lighting system and will also check on this phase of the installation.

Room Wallplates

Each room in the ballroom area has a control panel that fits in a standard 4 gang electrical box. The wallstation model number shall be ML-116/LU4S. The control is comprised of three components:

1. The 'ML-116-LUWP' control plate provided by FSR.
2. The '-4S' lighting control provided by Lutron.
3. The 'ML116/4S-FP' screwless faceplate provided by Lutron.

Equipment - Room Combining Control Interface

The integration of the lighting control system to the sound system combining panel, FSR model number 'ACU', shall be via contact closures, Lutron model number 'GRX-AV' or 'FSR-CIP' as the project requires. The integration shall allow the lighting controls to be combined/separated based on the status of the partitions on the 'ACU' panel, which is providing the same function for the audio controls.

The electrical contractor shall be responsible for the mounting of the 'GRX-AV' or 'FSR-CIP' interface and wiring to the lighting control system. The sound contractor shall be responsible for the wiring between the Lutron interface, the ML-116-INT, and the 'ACU' panel as well as the system setup to ensure proper operation.

MAP PANEL STATUS INTERFACE ML-116-INT

An ML-116-INT unit can output 32 mix switch or head table switch outputs. If both mix and head table information is required then then additional units can be added. The serial data from the ML-116 system would just loop thru each unit.

The ML-116-INT unit has an indicator LED for each corresponding wire terminal. These terminals denote either room combinations or head table positions. The inclusion of a LED for each terminal provides a rapid and accurate way to determine the operational status of both the ML-116 and the LUTRON lighting equipment.

A drawing of the ballrooms/meeting rooms is provided with each system. This drawing indicates the room mix switches and head table locations (via a numbering system) as they correspond to the appropriate terminal positions on the ML-116-INT. If multiple ML-116-INT units are required for either the mix or head table functions then the map drawing would indicate that and provide for it in the numbering system.

The actual unit is 7.5" long by 6" wide by 2" high, excluding the mounting ears each of the four of which are 1.5" wide by 0.5" long. The unit weighs approximately 3 lbs. It is located in the lighting equipment bay, not in the audio equipment area.

The ML-116-INT is supplied with a UL listed wall mounted transformer to power the unit.

It does not matter if the ML-116-INT is powered before or after the ML-116 Audio Control Unit. The ACU periodically scans for all line devices.

