

PWB-270/273

Project Wall Box for Crestron Devices

FSR

Metal Products Group

PWB-270

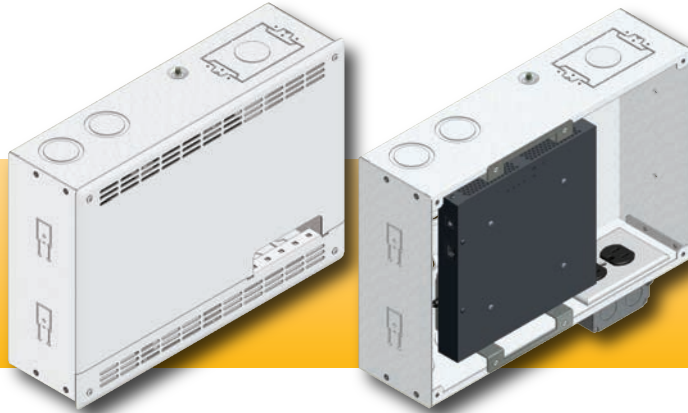

Intertek

CONFORMS TO UL STD 60950-1
CERTIFIED TO CSA STD C22.2 NO. 60950-1

DESCRIPTION

The PWB-270 housing is specifically designed to quickly and easily house a variety of Crestron model DM-RMC series devices behind a wall mounted display or a projector. The devices are mounted to a removable universal bracket which is in turn mounted to the PWB-270 back box. It is also available as a PWB-273 3" deep unit.

The back box is typically installed flush with the wall's surface, between either wood or steel studs. The appropriate mounting screws are included. A duplex box is also included for convenience and can be mounted at either the top or bottom duplex knockout areas on the back box. There are two 1" and 1.25" concentric knockouts on the top and bottom for cable/conduit entry and cable tie slots for cable management. Cable ties are included.

There is a two part vented cover, available in black or white, that provides convection cooling for the internal components. A slot on the cover facilitates passing cables through for external devices such as projectors and is designed to strain relief the cables as they exit.

FEATURES

- Rugged 16 gauge steel back box
- Black or white 1/16" painted two part cover
- Simple installation
- Hardware included
- Connections and cables are hidden behind cover for a neat install
- Multiple knockouts in a variety of sizes

OTHER PWB SERIES MODELS

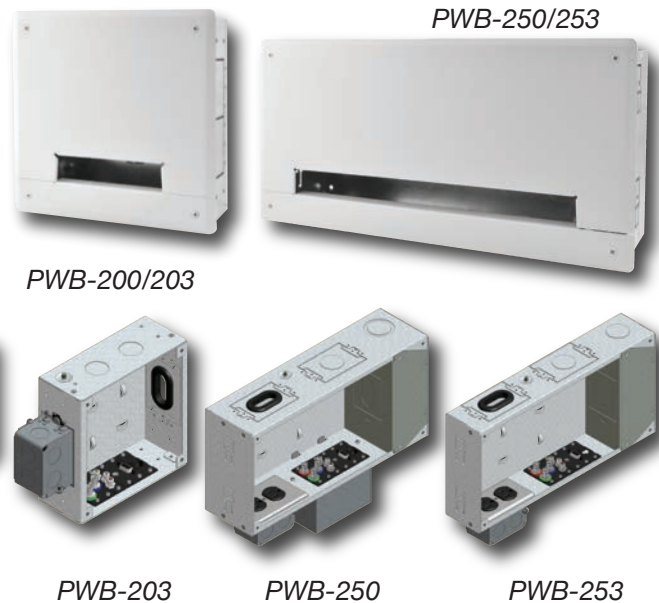

PWB-200

PWB-203

PWB-250

PWB-253

See LIT1352A for more details and ordering info

Touchboards

205 Westwood Ave, Long Branch, NJ 07740
Phone: 866-94 BOARDS (26273) / (732)-222-1511
Fax: (732)-222-7088 | E-mail: sales@touchboards.com

FSR Inc.

244 Bergen Boulevard, Woodland Park, NJ 07424
Phone: 973.785.4347 · Fax: 973.785.4207
Web: www.fsrinc.com · E-mail: sales@fsrinc.com
Order Desk: 1-800-332-FSR1 LIT1432A

PWB-270 DIMENSIONS



205 Westwood Ave, Long Branch, NJ 07740
 Phone: 866-94 BOARDS (26273) / (732)-222-1511
 Fax: (732)-222-7088 | E-mail: sales@touchboards.com

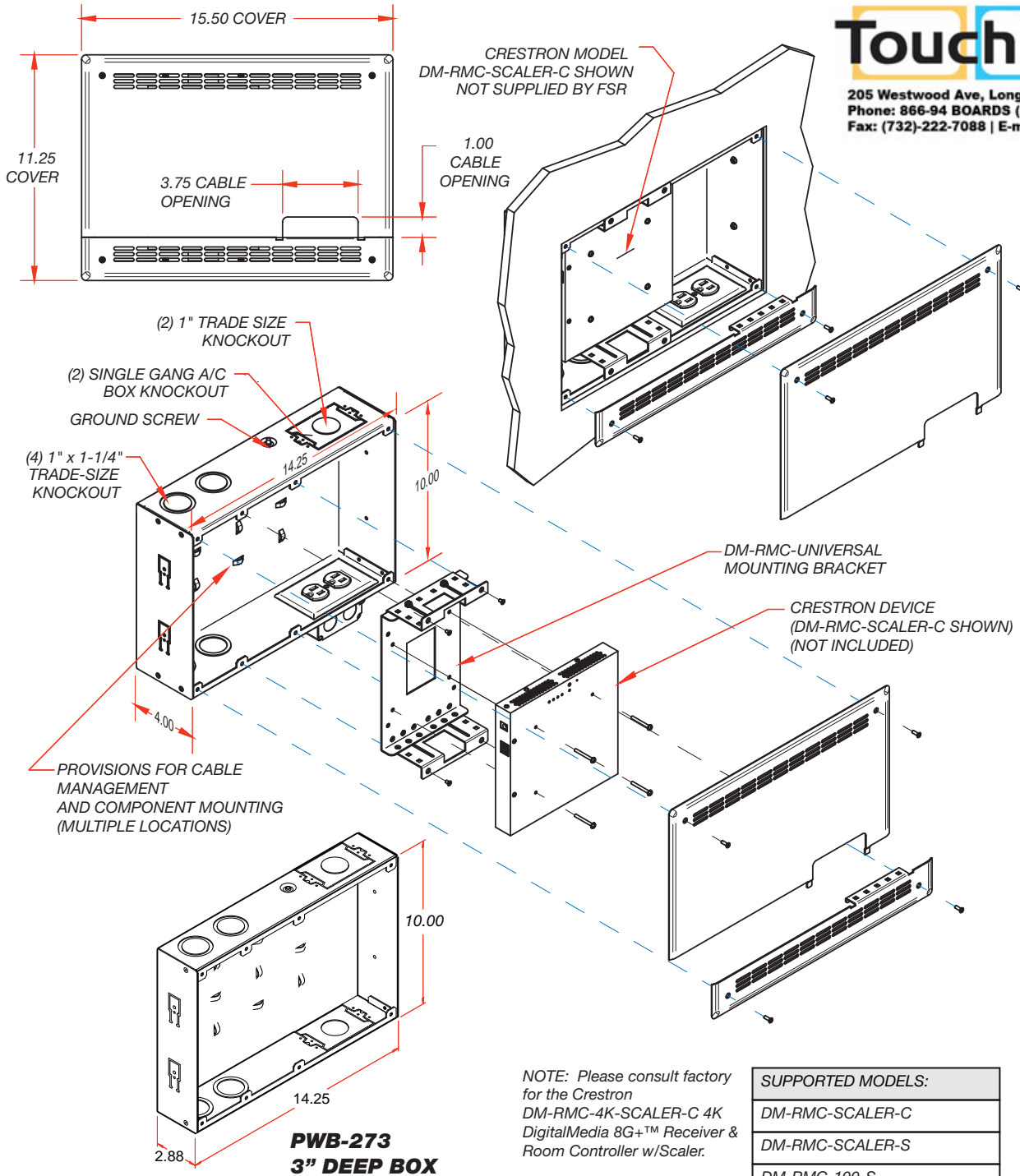

NOTE: Please consult factory for the Crestron DM-RMC-4K-SCALER-C 4K DigitalMedia 8G+™ Receiver & Room Controller w/Scaler.

SUPPORTED MODELS:	
DM-RMC-SCALER-C	
DM-RMC-SCALER-S	
DM-RMC-100-S	
DM-RMC-200-C	
DM-RMC-200-S	
DM-RMC-200-S2	
DM-RMC-4k-100-C	

NOTES:

1. WALL BOX MATERIAL IS 16 GA GALVENIZED STEEL.
2. COVER MATERIAL .062-THK ALUMINUM, PAINTED.
3. STANDARD EQUIPMENT INCLUDED: MOUNTING HARDWARE FOR WOOD AND STEEL STUDS, JUNCTION BOX AND BRACKET FOR MOUNTING CRESTRON DM SCALER.

Specifications are subject to change without notice.



244 Bergen Boulevard, Woodland Park, NJ 07424
 Phone: 973.785.4347 · Fax: 973.785.4207
 Web: www.fsrinc.com · E-mail: sales@fsrinc.com