

PWB-450

Large Project Wall Box

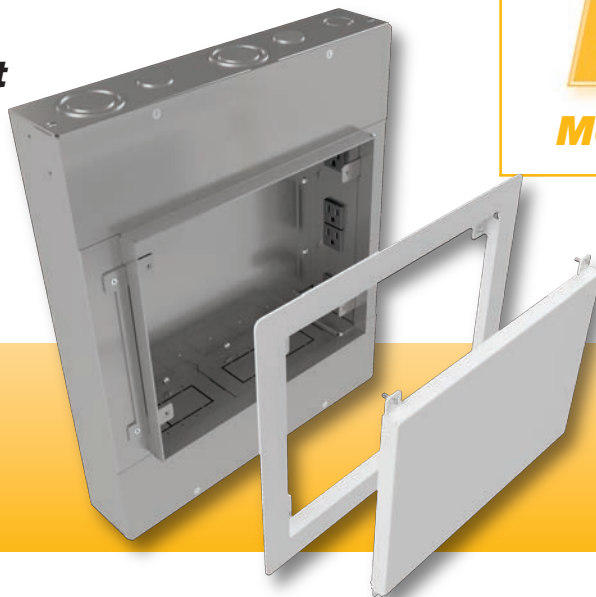

FSR

Metal Products Group

Touchboards

205 Westwood Ave, Long Branch, NJ 07740
Phone: 866-94 BOARDS (26273) / (732)-222-1511
Fax: (732)-222-7088 | E-mail: sales@touchboards.com



PWB-450

DESCRIPTION

The standard PWB-450 is the largest of our PWB series. Two mounting brackets are available for mounting the Crestron DM-RMC-4K-SCALER-C receiver/room controller or other digital media interfaces and devices.

The PWB-450 mounts in a typical 4" deep wall between the studs in a standard 16" stud bay. It provides connectivity, internal device mounting and power in a secure and invisible manner. The cover is flush to the wall allowing the display to be mounted as close as its mount will allow. The cover is ventilated top and bottom to provide convection cooling as well as a cable exit slot to pass cables from the box to the display.

Inside the PWB-450 are four (4) pre-wired AC outlets along one vertical side of the box which are isolated from the four (4) accessory plate mounting brackets to allow AC and low-voltage connections within the same box. There is a 1/2" - 3/4" concentric KO on the top and bottom of the box for the AC conduit connections. 1" KO's in the divider plates allow the use of one or more accessory plates for AC connections.

Three of the accessory plate brackets are punched for a single gang Decora opening while the fourth bracket is punched for FSR's IPS Connector Plates. Behind each bracket is a 3/4" and a 1"-1 1/2" concentric KO providing ample wiring flexibility and easy installation. Any or all of the accessory plate mounting brackets can be removed to provide space to mount larger devices. When using the optional PWB-450-DM4k bracket for the Crestron DM-RMC-4K-SCALER-C two (2) of the accessory plate brackets will be removed from the box.

FEATURES

- Rugged 14 Gauge Steel
- Black or White cover options
- 4 pre-wired AC outlets (1 rotated)
- Simple installation
- Removable Internal Brackets to accommodate larger devices
- Mounting Hardware Included
- Optional PWB-450-DM4k Bracket accommodates Crestron DM-RMC-4K-SCALER-C
- Optional PWB-450-MMS Bracket accommodates other digital media interfaces/devices

APPLICATIONS

- Digital Signage
- Huddle Areas
- Hospitals
- Conference Centers
- Schools
- Airports
- Command Centers
- Electronic Billboards
- Museums
- Arenas

**FIRE RATED
VERSION AVAILABLE
FEB. 1, 2016**

PART NUMBER
PWB-FR-450

FSR Inc.

244 Bergen Boulevard, Woodland Park, NJ 07424
Phone: 973.785.4347 · Fax: 973.785.4207
Web: www.fsrinc.com · E-mail: sales@fsrinc.com
Order Desk: 1-800-332-FSR1

LIT1562A

PWB-450 DIMENSIONS

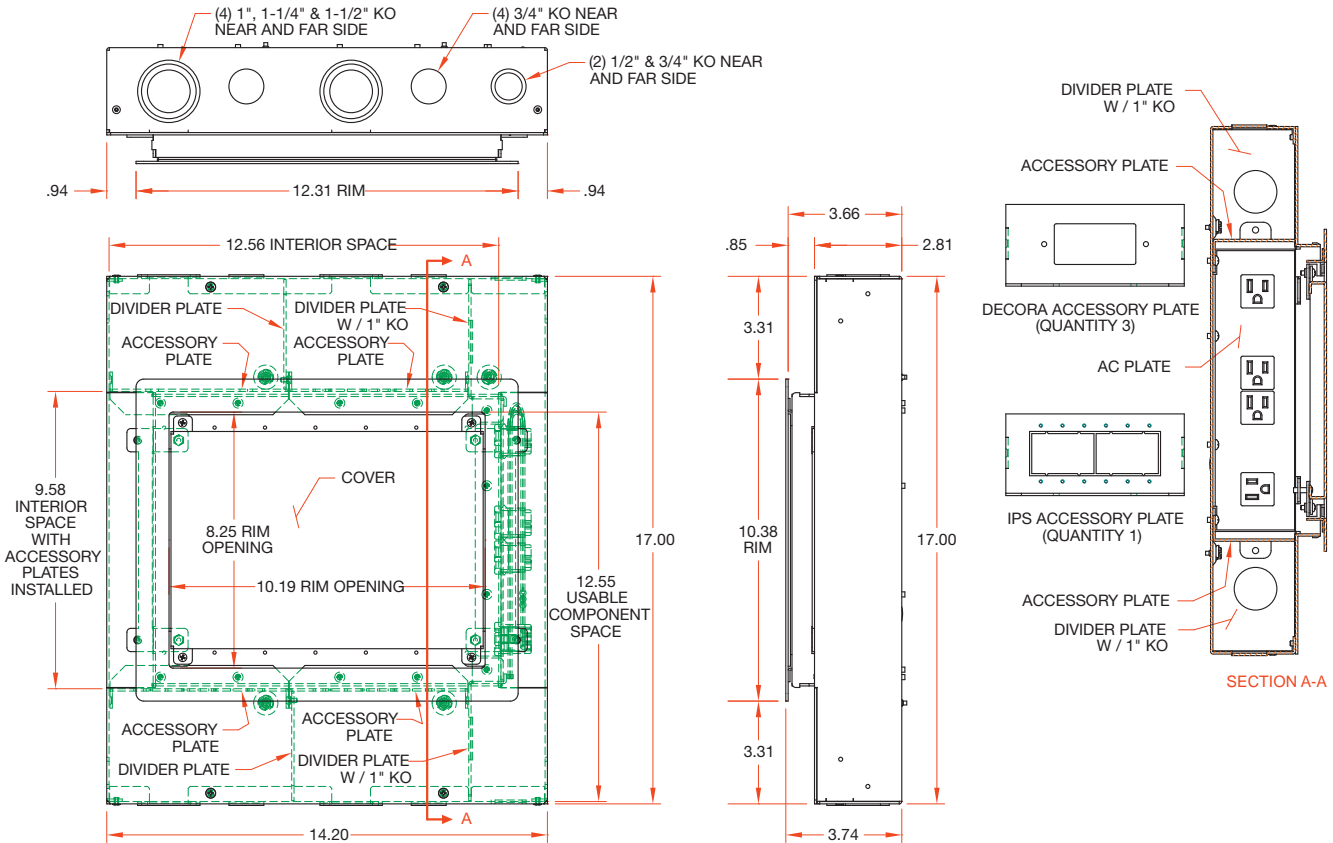

PWB-450 BRACKETS

Optional PWB-450-DM4k Bracket for Crestron DM-RMC-4K-SCALER-C

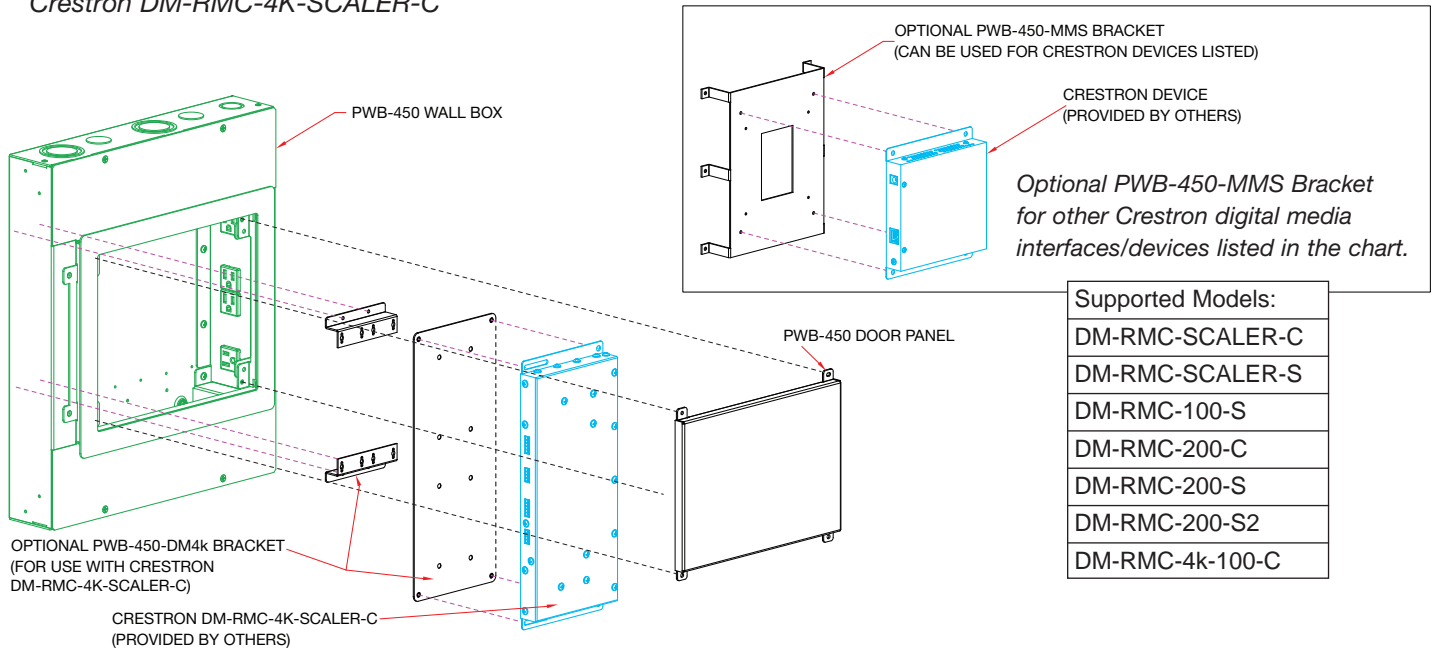

Specifications are subject to change without notice.



244 Bergen Boulevard, Woodland Park, NJ 07424
 Phone: 973.785.4347 · Fax: 973.785.4207
 Web: www.fsrinc.com · E-mail: sales@fsrinc.com