

Technical Specifications



Touchboards

205 Westwood Ave, Long Branch, NJ 07740
Phone: 866-94 BOARDS (26273) / (732)-222-1511
Fax: (732)-222-7088 | E-mail: sales@touchboards.com

38955	36" single desk
38957	72" double desk
38956	42" single desk w/ ADA clearance

38958	36" single desk w/ lock
38960	72" double desk w/ lock
38959	42" single desk w/ ADA clearance & lock

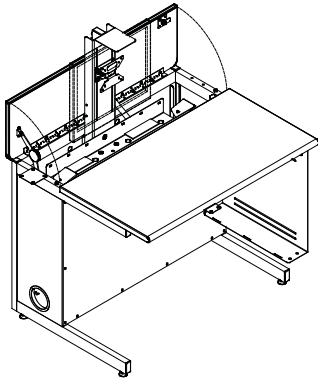

36" single desk

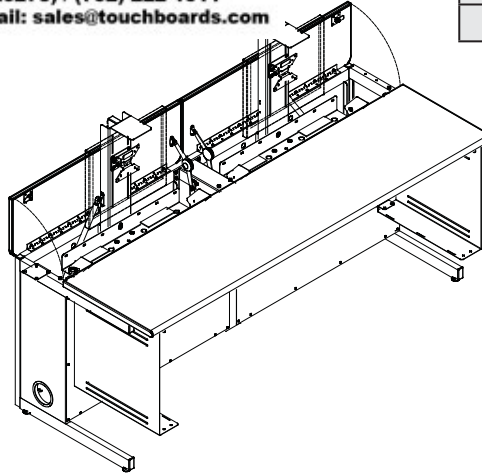

72" double desk

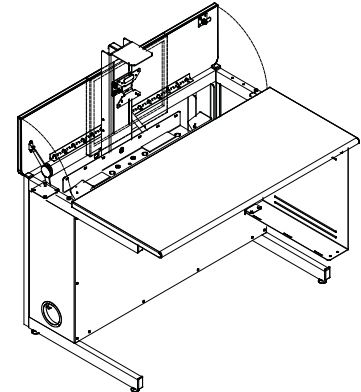

42" single desk w/ ADA clearance

The Flex Insight Computer Desk was designed to maximize classroom space and functionality. The desk allows a lecture room to be converted to a computer lab and back in a matter of seconds by bringing a recessable computer monitor to the user with manual lift. The monitor can be lowered just as quickly when not needed. Available in single (36") double (72") and ADA (42") versions.

Features and Benefits

- Desk allows any classroom to be reconfigured from a lecture hall to a computer training lab
- Manually-actuated monitor column with pneumatic cylinder assist allows the monitor, keyboard, and mouse to be moved up when needed, and retracted with the lid closed to convert the desk to a conventional student desk
- Vertical lift of monitor to eye level above desk provides ergonomic viewing angle to prevent user fatigue
- Proven triple ball bearing rail lift column design provides smooth operation, reliability, and long life
- Monitor compartment lids protect and secure the flat panel monitor, keyboard, and mouse, provides 19" of free workspace in front of lid (one lid on 36" & 42", two on 72")
- Friction dampener on monitor lid provides support and dampening, and slows the lowering of the lid, keeping hands and fingers safe
- Unique adjustable height, pivoting VESA mounting system included provides up/down, and left/right adjustability, and works with a wide array of flat panel monitors
- Cord channel conveniently keeps computer wires and cables out of the way, and is wide enough to accept most power strips
- Large, 4" side-panel cord management grommets create a continuous cord channel when desks are placed side-by-side
- Adjustable CPU sling with heavy-duty adjustable straps for CPU storage will fit 4" to 8" wide computer towers up to 18" high x 18" deep
- Wire loom protects wires and cables between CPU and monitor
- Removable rear security panel provides security and easy-access to cables and equipment (secured with 4mm JC Bolts and hex wrench)
- Scratch and impact-resistant, high-pressure laminate worksurfaces (1¹/₁₆" worksurface, 1³/₁₆" monitor lid)
- Ergonomic, Evolution style rolled front edge is easy on wrists
- Quick-connect unit-to-unit brackets allow tables to be connected together, preventing cord pinching
- Lift mechanism allows a nominal 16" of lift above the table worksurface, supporting select 16:9 monitors up to 24" diagonal, weighing between 7-14 lbs
- All wires are protected from student-access by an enclosed metal compartment to prevent tampering-insuring valuable classroom instruction time
- Tie downs in wiring tray secure power cables and wires
- Warranted to be free of all defects in materials and workmanship with a 10-year warranty. (1-year on pneumatic lift cylinder)

Options & Accessories
Page 7

Color Options

Standard laminate / color combinations

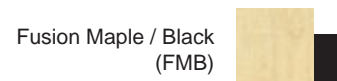
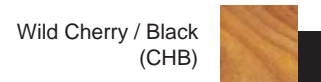

Standard color combination refers to the quickest deliverable product color combination. Custom laminates and color combinations are available-additional lead-times and up-charges may apply. Call 1-800-235-1262 for further information.

Construction

- The top worksurface is constructed from 1¹/₁₆" thick NAUF (No Added Urea Formaldehyde) composite board with .030 high-pressure laminate, and a balancing phenolic backer on the bottom side. The left, right, and rear edges are finished with 3mm vinyl edge-band.
- The monitor compartment lid worksurface is constructed from 3/4" thick industrial-grade composite board with .030 high-pressure laminate on both sides-all edges are finished with 3mm vinyl edge-band
- CPU sling has two deluxe 1" nylon straps with a locking buckle to secure CPU
- Welded, 16-gauge 1" x 2" rectangular steel tube legs
- Upper leg panel, 14 gauge
- Worksurface edges are covered with 3mm vinyl
- All metal components are finished with a scratch-resistant powder coat epoxy paint
- Each Flex Insight Desk is factory-assembled, packaged and shipped on its own skid

Capacity

Lift mechanism	manually-actuated with pneumatic and spring-assist
Lift capacity	7-14 lbs (factory preset)
Maximum monitor size	24"W x 16"H x 5 ¹ / ₂ "D
CPU Sling(s)	4"-8"W x up to 18"D x up to 18"H One on single desks, two on double desks
Wiring Tray(s)	32"W x 9 ³ / ₄ "D x 3 ³ / ₄ "H - 36" single 64"W x 9 ³ / ₄ "D x 3 ³ / ₄ "H - 72" double 37 ⁵ / ₁₆ "W x 9 ³ / ₄ "D x 3 ³ / ₄ "H - 42" ADA
Lower wiring tray power cutouts	5"W x 3 ¹ / ₈ "D (two per tray)
ADA-compliant knee space (ADA version only)	33 ⁵ / ₈ "W x 19"D x 28"H 
Unit weight (nominal)	107 lbs - 36" single 206 lbs - 72" double 120 lbs - 42" ADA
Shipping weight (nominal)	144 lbs - 36" single 266 lbs - 72" double 157 lbs - 42" ADA
Meets or exceeds all ANSI-BIFMA test standards	

Specifications subject to change without notice

Included with Desk:

- (1) CPU sling-single desk, (2) CPU slings-double desk (each sling includes two heavy-duty 1" nylon straps)
- Swivel VESA mount with mounting screws
- Deluxe internal heavy-duty metal keyboard / mouse tray
- (10) zip ties
- 4mm hex wrench for instructor-access
- Two keys are included with each lock (locking desks only)
- Wire loom for keyboard, mouse, and monitor cables protect cables from pinching
- Rubber keyboard tray pads (protect keyboard)
- One unit-to-unit bracket (desks must be same height to connect)

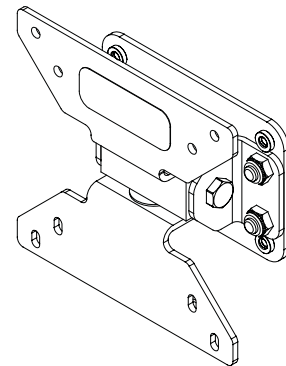

Standard Swivel VESA Monitor Mount w/ internal travel stops
provides 4-direction tilt (4° left, 4° right, 16° up, and 6° down.) Works with 75mm and 100mm VESA monitor mounts (includes mounting screws)

Note: Specific monitor size, shape, & mounting location will determine exact angles of tilt.

36" Flex Insight desk w/ locking lid

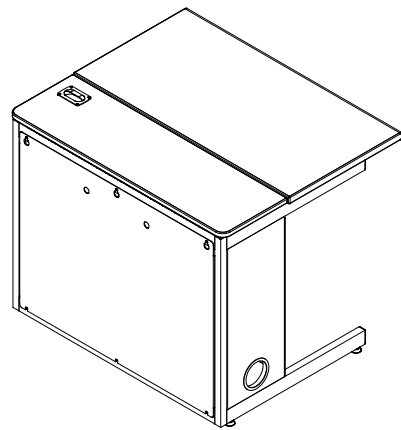
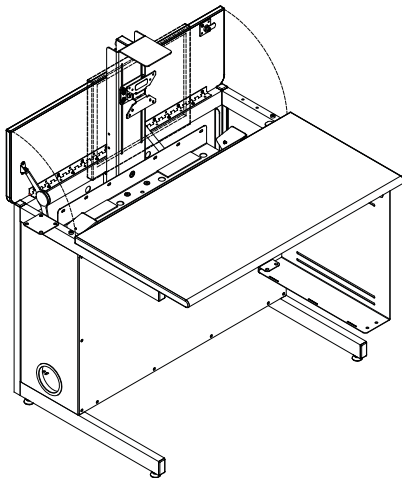
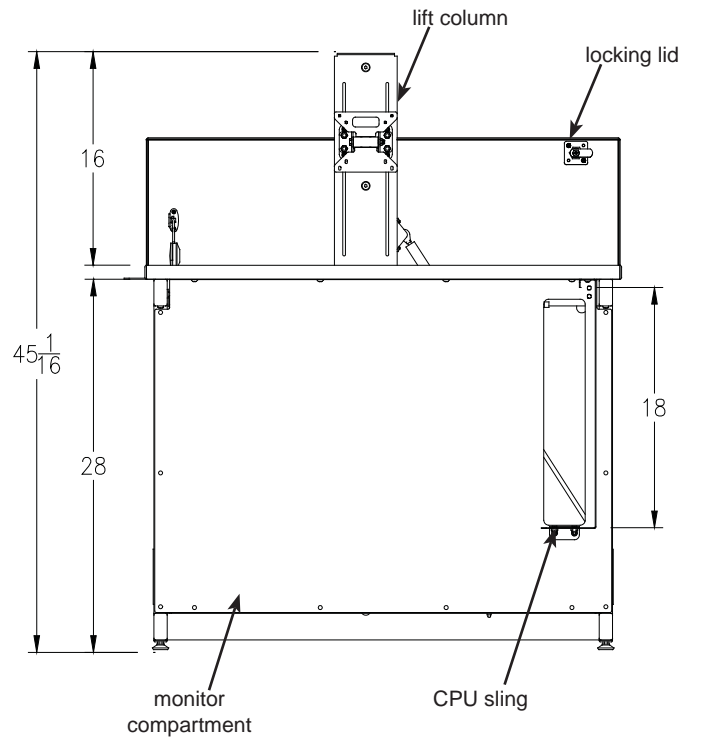
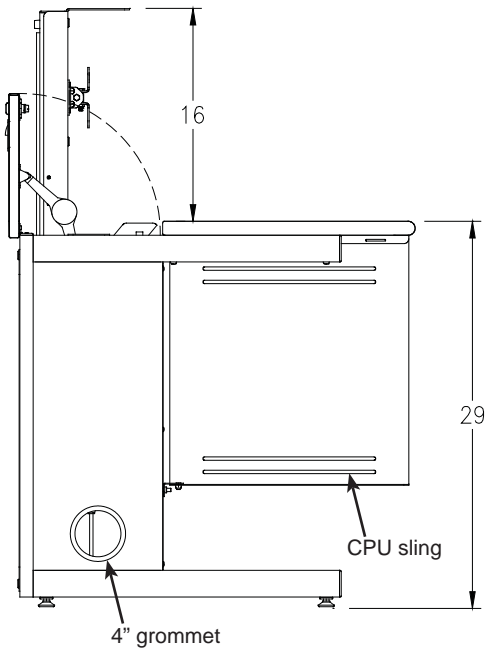
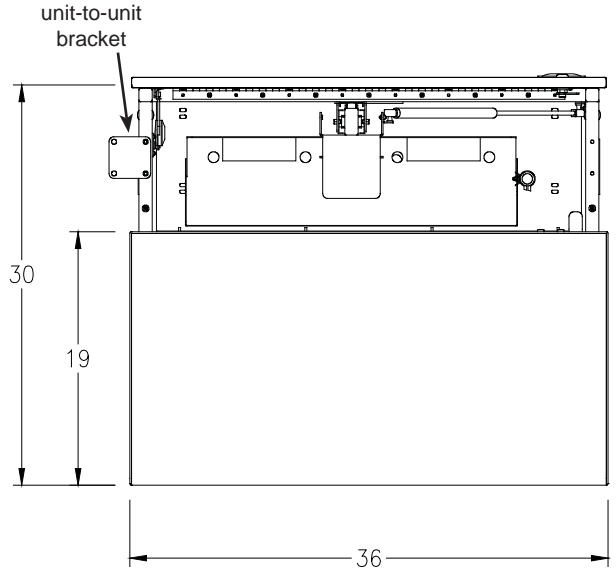

72" Flex Insight double desk
w/ locking lid

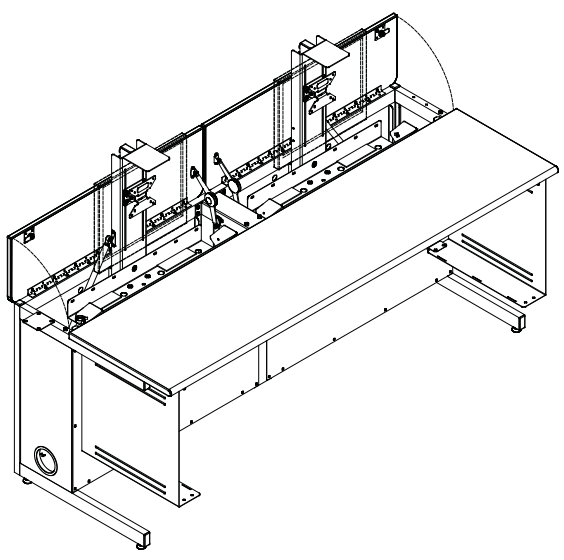
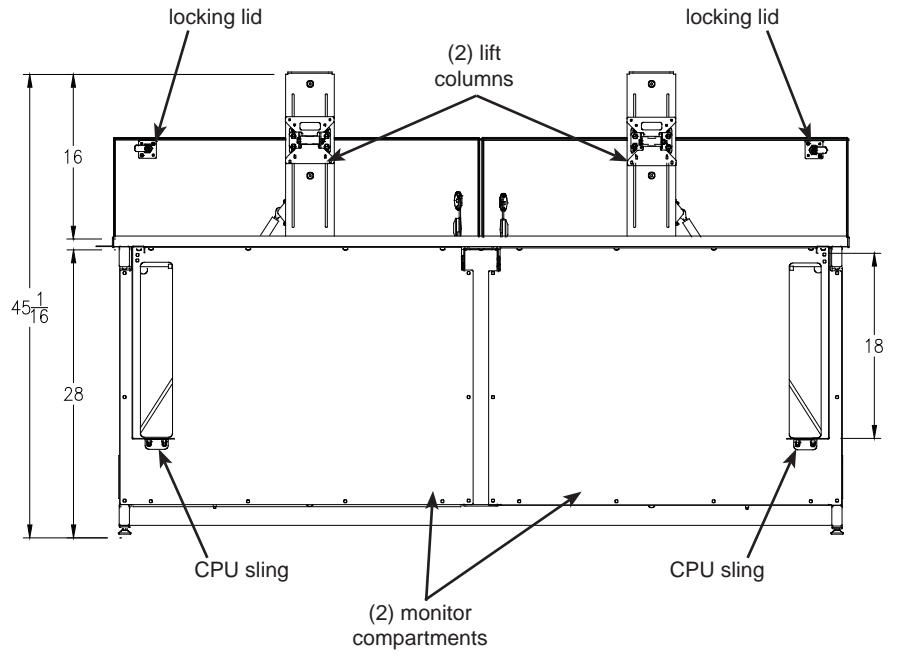
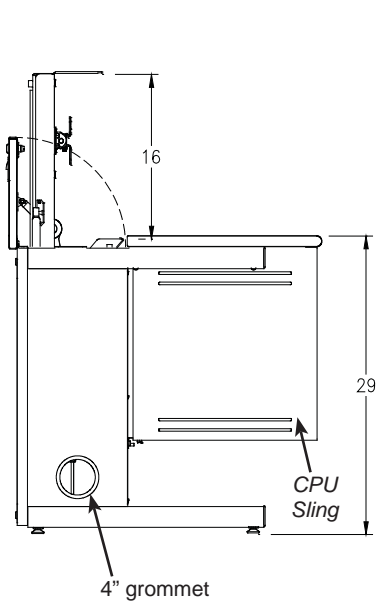
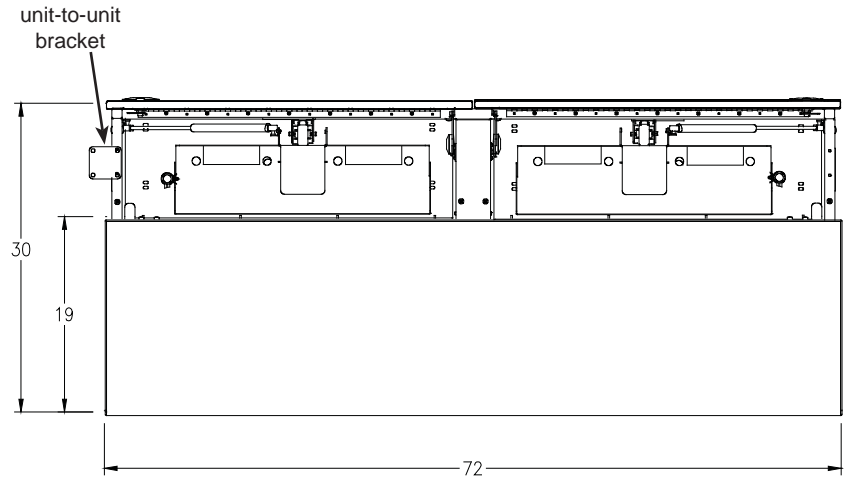

42" Flex Insight ADA desk
w/ locking lid

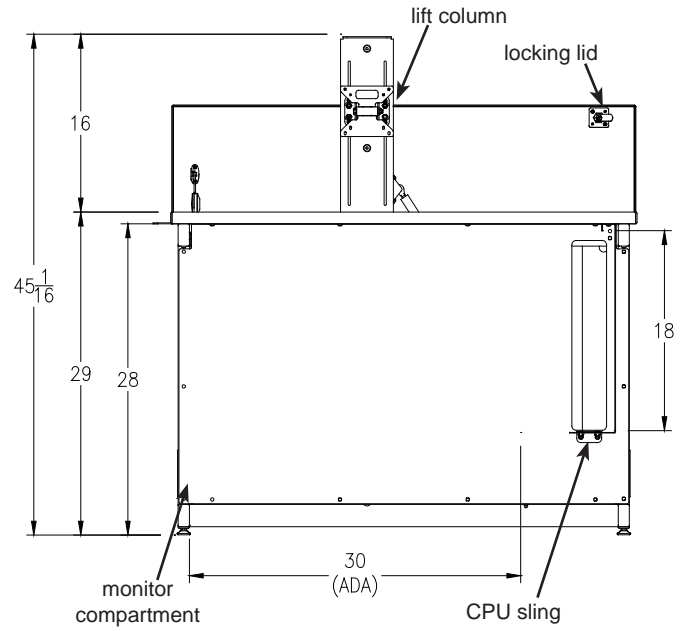
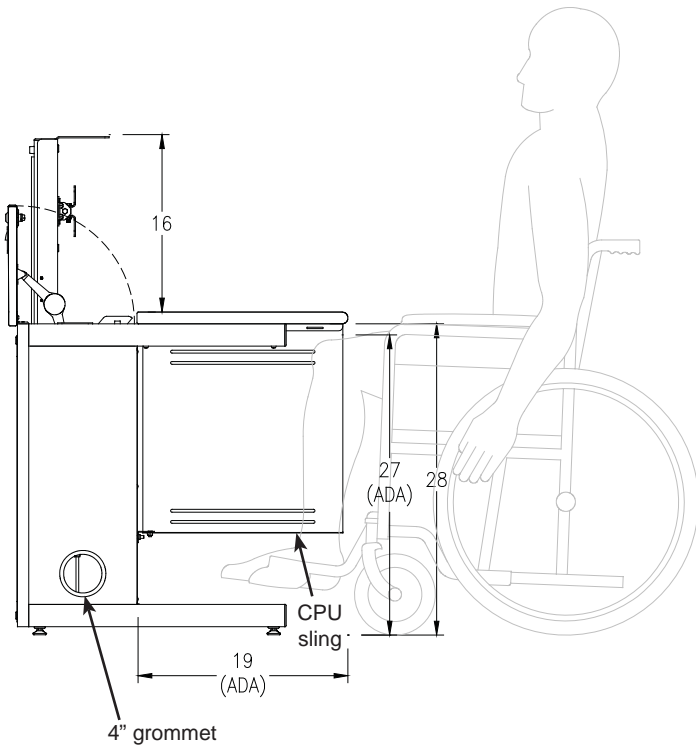
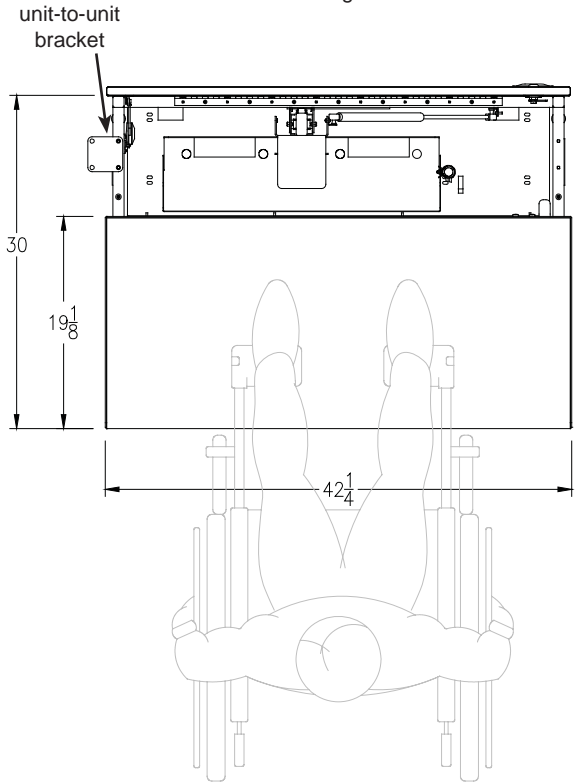
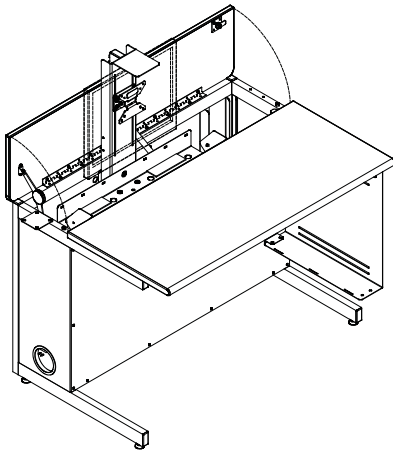

Note: Minimum ADA guidelines for knee clearances are 30"W x 19"D x 27"H.

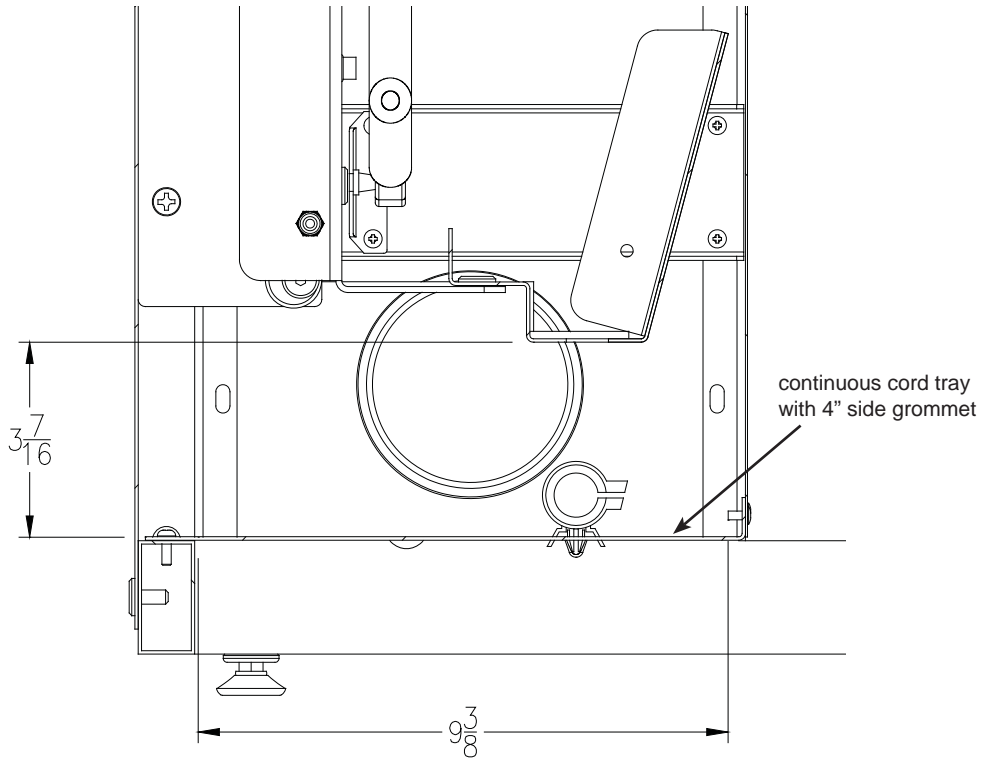

wiring tray
section view

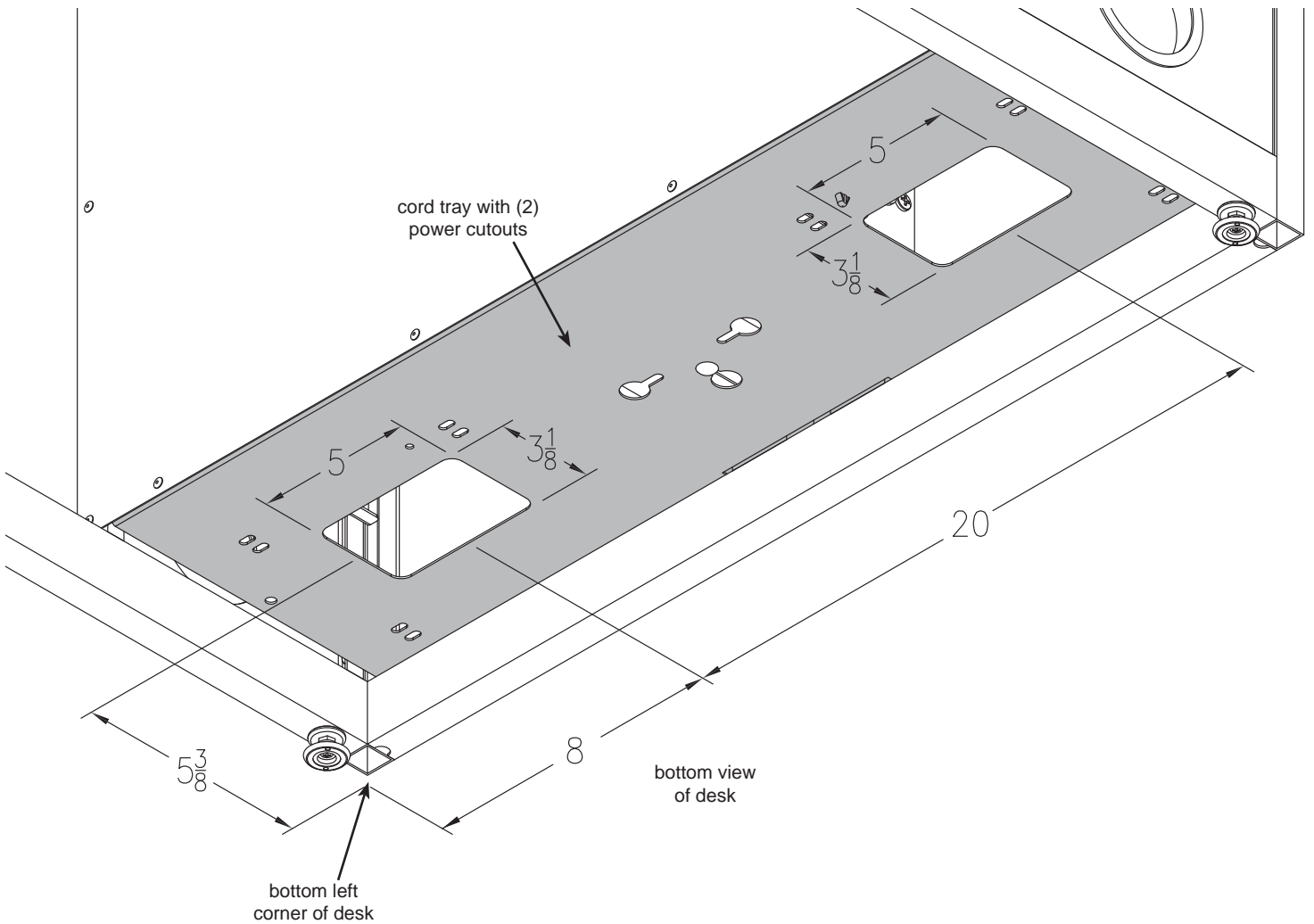

Options

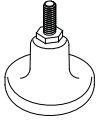

1" Bell Glide Riser Kit
 raises worksurface height from
 29" to 30" (set of 4)
 98513

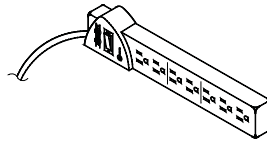

7-Outlet Power Strip, insured
 w/ surge protector, bracket, and 12' cord
 99024

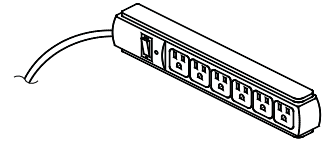

6-Outlet Power Strip
 w/ 12' cord
 99023

EP8 Kits & Accessories

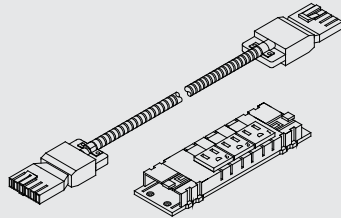

EP8 Kit for 30" Desk - 99014
36" Desk - 99008
44" Desk - 99009
48" Desk - 99018
60" Desk - 99010
72" Desk - 99011
Corner Printer - 99012
Center Printer - 99013

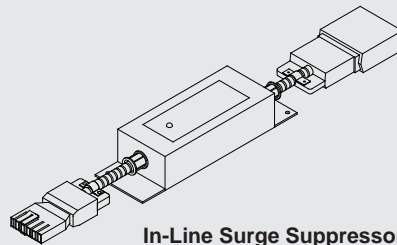

In-Line Surge Suppressor
 99016

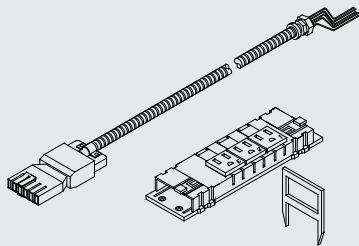

Base Power Feed
 w/ 36" flexible cord
 99022

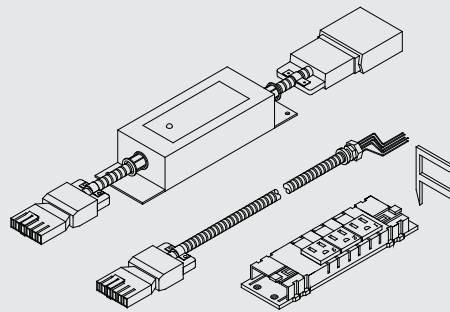

Starter Surge Suppressor
 w/ 12' pigtail cable
 99017

Warranty

WE WILL MAKE IT RIGHT FOR YOU!

Spectrum is committed to provide complete customer satisfaction. Each of our products are manufactured from the best materials available and each product is stringently monitored throughout the production process through our P.A.C.E. program (Product Assurance to meet Customer Expectations). Our Customer Service Help Line 1-800-235-1262 is ready to provide immediate attention to any questions, comments or concerns. We are available to answer your calls Monday through Friday from 7 am to 5 pm CST, excluding observed holidays. In addition your product comments or concerns are welcome via e-mail at: spectrum@spectrumfurniture.com.

Warranty Statement

We guarantee all Spectrum products to be free of all defects in materials and workmanship, for the original owner, for a period of ten years. Any item deemed defective by Spectrum or the original manufacturer, under normal use conditions, will be repaired or replaced at Spectrum's discretion. This warranty applies to all products manufactured and distributed by Spectrum except the products listed below.

Items that have a varying warranty include, but are not limited to, the following:

- Adjustable Crank/Electric Desk Legs (1 yr)
- Flat Panel Desk Gas Cylinders (1 yr)
- Upholstered Soft-Goods (5 yrs)
- Adjustable Height & Stacking Chair Parts – including frames, gas cylinders, wood and plastic parts, and control handles (7 yrs)
- Adjustable Height & Stacking Chair Casters (2 yrs)
- Chair Upholstery & Textiles (2 yrs of normal use of Soft Goods, Adjustable Height, Stacking, Wood and Metal Chairs)
- Chair Upholstery - Graded-In Fabrics and C.O.M (no warranty)
- Height Adjustable Columns and Lifts (1 yr)
- General Use Casters (1 yr)
- Electrical – Electri-Pak, Power Communication Modules, and special order ECA electrical items (1 yr)
- Electrical - Power Strips & Electrical Timers (1 yr)
- Electrical Surge Suppressors (lifetime)
- Electrical - Retractable Power Cords (1 yr)
- Keyboard/Mouse Trays (1 yr)
- Flat Panel Monitor Arm – General Parts (5 yrs)
- Flat Panel Monitor Arm – Gas Cylinders (2 yrs)
- CRT Monitor Arm (1 yr)

Warranty is void if product is not used for its intended purpose or subjected to an unusual application, multiple-shift use, alteration, accident, abuse or abnormal wear and tear. Representations of colors on-line and in printed materials are meant to be a close reference to the actual colors but not an exact match. Slight variations in color and texture of wood stains, powder coating, laminates, fabrics and other materials are normal in different manufacturing lots; as such these variations are not considered defects.

DESIGNED FOR INDOOR USE ONLY – Unless specifically stated in the product specifications, Spectrum's products have been designed and constructed for indoor use only. Moving or using outdoors, or on excessively rough surfaces, may cause damage to the products and will void the warranty. If an outdoor application is desired please contact us to discuss potential custom design solutions.

The warranty, as stated above, supersedes any previous warranties and is effective as of 9/1/2010



Touchboards

205 Westwood Ave, Long Branch, NJ 07740
Phone: 866-94 BOARDS (26273) / (732)-222-1511
Fax: (732)-222-7088 | E-mail: sales@touchboards.com

