

# Owner's Manual

## Flex Insight Computer Desk

#38955 36" Single  
#38957 72" Double  
#38956 42" Single w/ ADA clearance

#38958 36" Single w/ lock  
#38960 72" Double w/ lock  
#38959 42" Single w/ ADA clearance & lock

# Touchboards

205 Westwood Ave, Long Branch, NJ 07740  
Phone: 866-94 BOARDS (26273) / (732)-222-1511  
Fax: (732)-222-7088 | E-mail: sales@touchboards.com

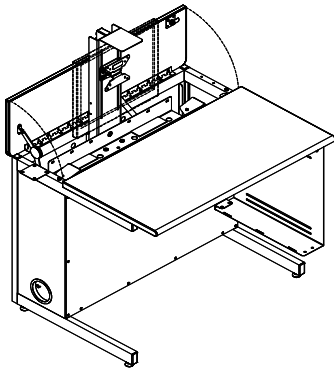

36" Single Desk

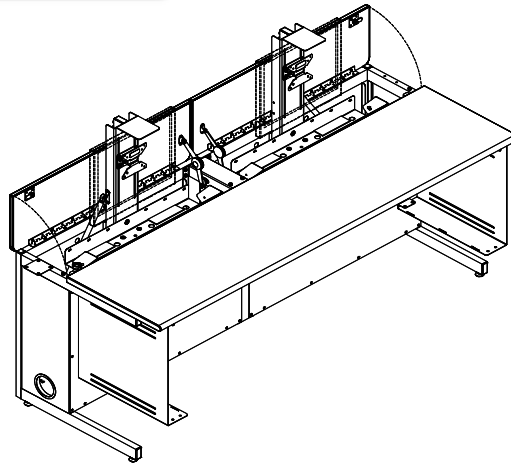

72" Double Desk

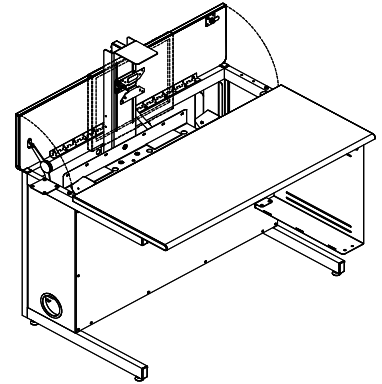

42" Single Desk w/ ADA clearance

### **CAUTION:**

Before using this product, read this manual and follow all safety and operating instructions.

### **IMPORTANT:**

Before you begin, please make sure all parts and proper quantities are included. Any parts damaged during shipment must be reported within 15 days of receipt. To report information regarding damages or if you have any questions, please call 1-800-235-1262.

To purchase parts or accessories, please contact us at  
[www.spectrumfurniture.com](http://www.spectrumfurniture.com)  
1-800-235-1262

Thank you for choosing Spectrum products!





## Safety



- Read this owners manual before assembling or operating this desk.
- Keep fingers and hands away from the edges of monitor compartment lid and clear of the lift mechanism when raising or lowering to prevent pinching.
- Do not sit or allow students to sit on top of desk or monitor compartment lid.
- Do not exceed the maximum monitor weight rating of 14lbs.

## Hardware package contents

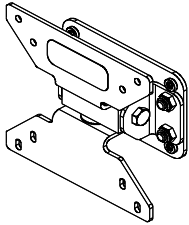

**Standard Swivel VESA Monitor Mount w/ internal travel stops**  
provides 4-direction tilt, and works with 75mm and 100mm VESA monitor mounts (includes mounting screws)

(1) 0107624 w/ single desks  
(2) 0107624 w/ double desks

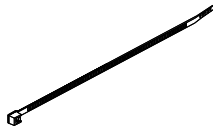

**11" Zip Ties**  
(10) 0102376 w/ single desks  
(15) 0102376 w/ double desks

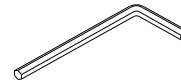

**4mm Hex Wrench**  
(1) 025039

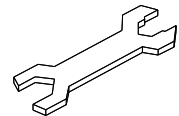

**Glide Wrench**  
(1) 025069

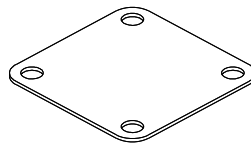

**Unit-to-unit bracket**  
(1) 0107574



**1/4-20 x15mm JC Bolts**  
(4) 052605

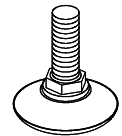

**5/16-18 Glides**  
(4) 025068

## Assembly / Setup

Tools Required:



**Phillips and Flat Head Screwdrivers**

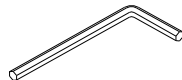

**4mm Hex Wrench (included)**

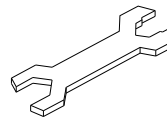

**Glide Wrench (included)**

### **Unlock monitor column first**

**Note:** Every Flex Insight desk ships with one or two carriage bolts with wing nuts locked in a keyhole slot under the bottom of the keyboard tray. These fasteners prevent monitor column movement during shipping, and will need to be removed to get the monitor column to function. A picture of the bolt and wing nut is shown here from the back side of the desk. To remove, unscrew the wing nut by hand, and slip the bolt out of the keyhole slot. The fasteners should be retained for reuse if you will be transporting the desk.

If you transport the desk (in a trailer or truck) it is recommended to replace the carriage bolt and wing nut. To replace, start the wing nut on the end of the bolt and push the monitor column down into the lowered position. Wiggle the head of the bolt into the slot from the large side of the keyhole. Let the monitor column rise slightly to put tension on the wing nut. Tighten down until monitor column does not move and is secure.

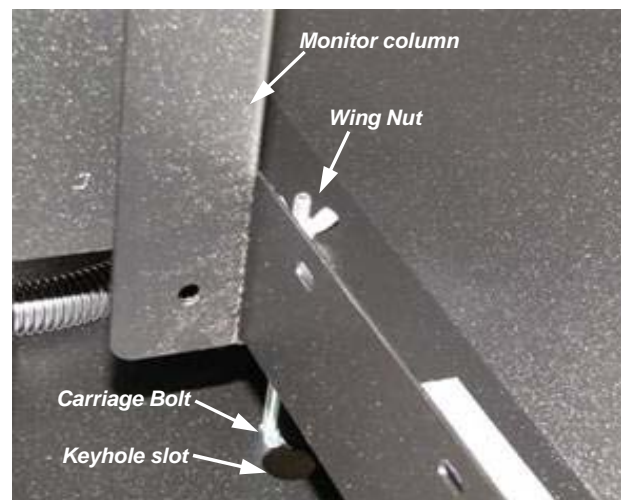

## 1. Installing Glides

- A. Carefully lift one side of the desk and place a short wooden 4x4 or 2x4 block (or equivalent support) under the leg. This may require two people. **Figure 1.**
- B. Thread the two glides into the leg, tighten securely, and remove block.
- C. Repeat this procedure on the other side of the desk.
- D. The glides can be adjusted with the included glide wrench to level the desk if necessary.

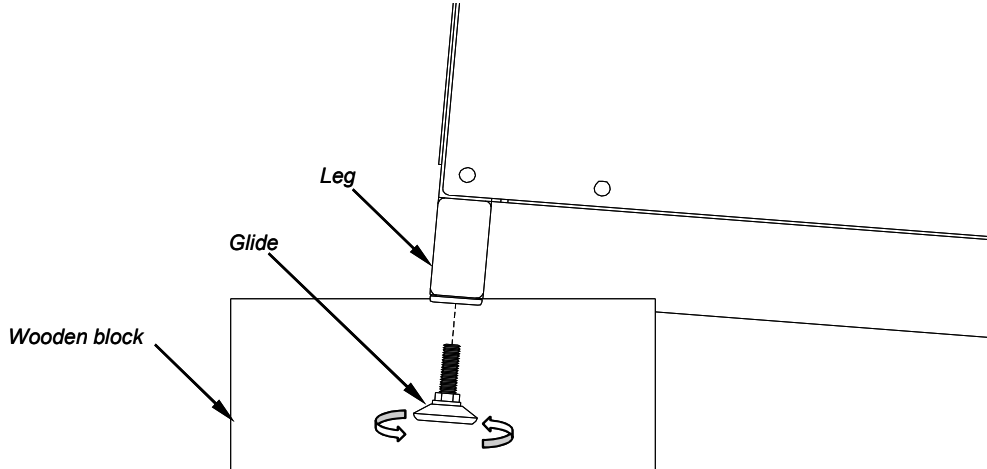

## 2. Connecting Desks Together

- A. Desks of equal height can be connected together with the included unit-to-unit bracket. **Figure 2.**
- B. Align desks next to each other in their final location and raise monitor compartment lids.
- C. Attach desks together with a unit-to-unit bracket and (4) 1/4-20 x 15mm JC bolts. Tighten bolts securely.
- D. Disconnect brackets to move/relocate desks.

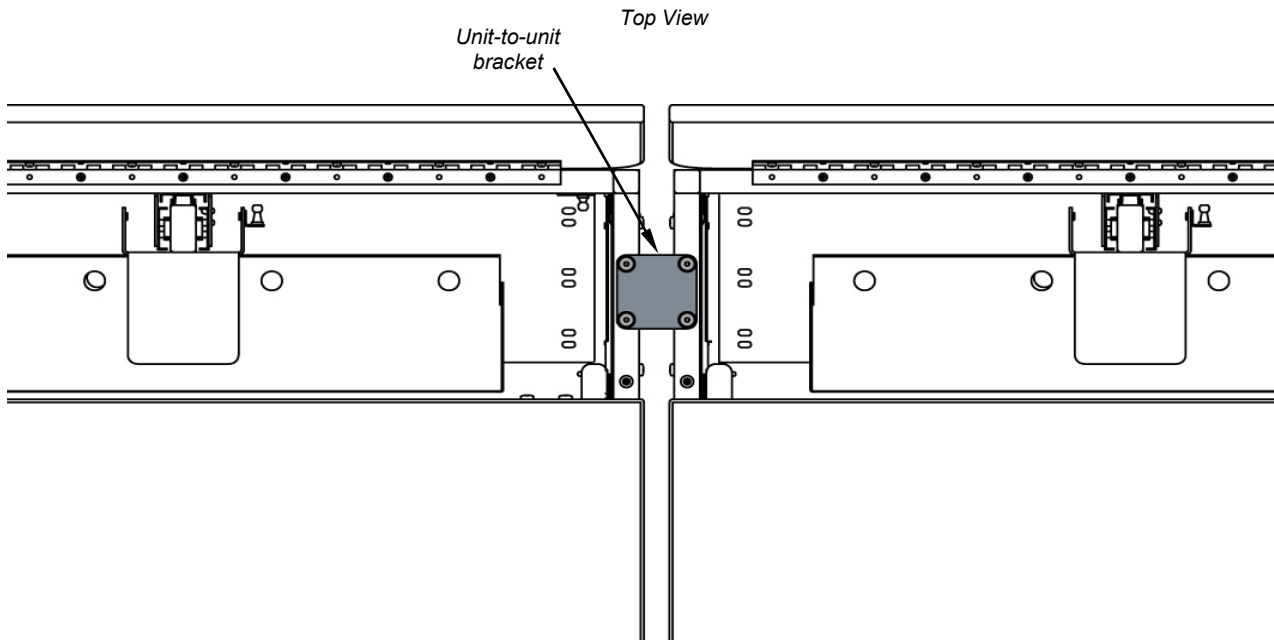

Figure 2

### 3. Installing Flat Panel Monitor

- A. Loosen the back panel JC bolts slightly with a 4mm hex wrench, lift off the back panel, and open the monitor compartment lid
- B. Attach the Swivel VESA mount to your flat panel monitor with (4) 4mm PHMS screws. **Figure 3A.**  
**Note: On most flat panel monitors, it will be necessary to remove the standard base that comes with the monitor to use the VESA mounting option.**
- C. Position your monitor with the lift column and align the VESA mounting holes with the lift column slots. Leave a small gap between the top of the monitor and lift bracket to provide clearance for the monitor to fully tilt.
- D. Attach the swivel VESA mount and monitor to the lift column with (4) 10-24 x 1/2" screws as shown in **Figure 3B.**  
Tighten screws securely.

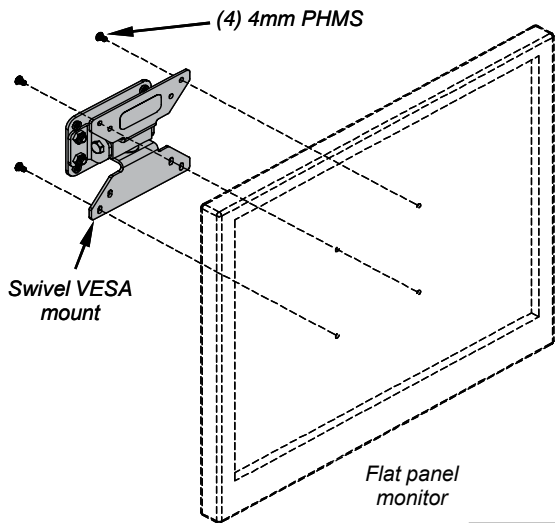

Figure 3A

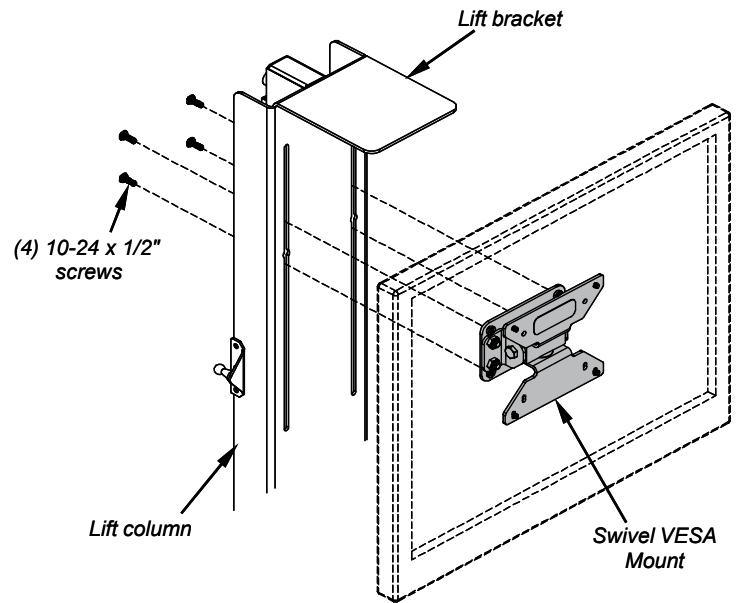

Figure 3B

### 4. Installing CPU

- A. Set the CPU unit into the CPU sling.
- B. Make sure the CPU will be supported by both straps. Tighten the straps around the CPU while keeping the buckles positioned as high as possible to avoid interference. **Figure 4A.**

**Note:** The center slot can be used for better support of smaller profile CPU's. If the center slot is necessary, take the rear strap out of the rear slot and thread into the center slot shown in **Figure 4A.** Thread the strap as shown in **Figure 4B.**

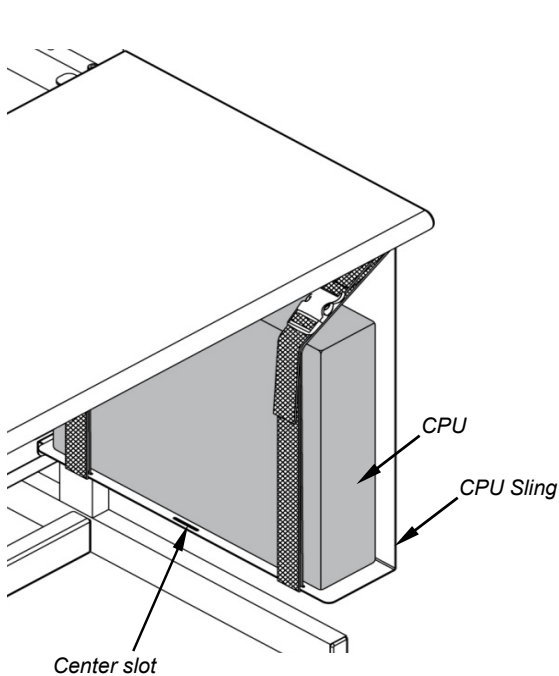

Figure 4A

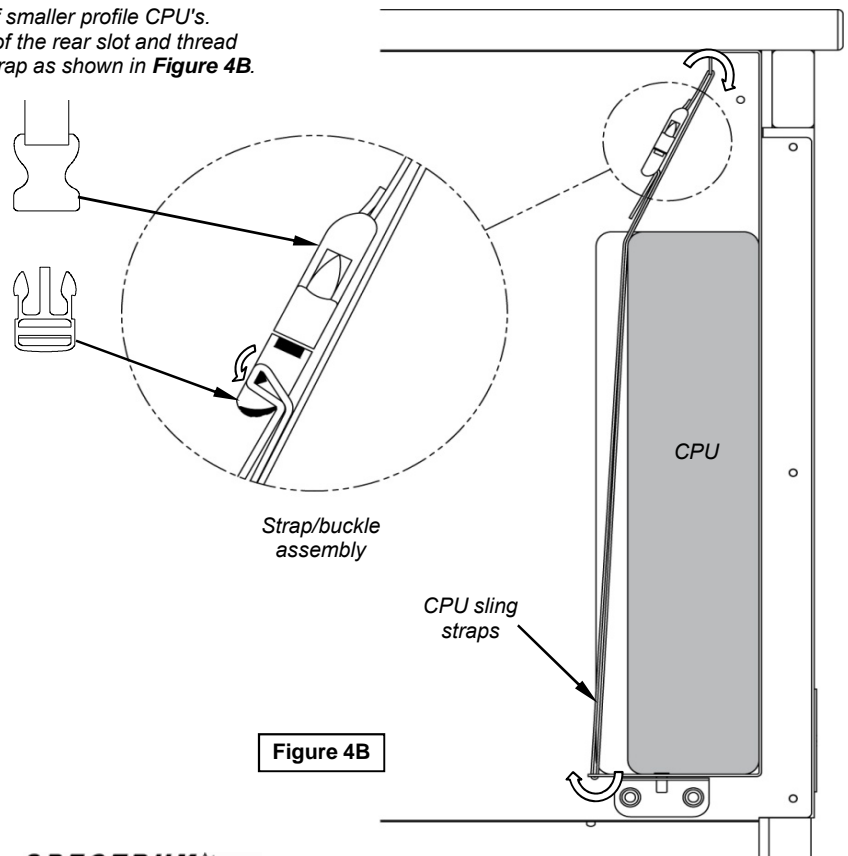

Figure 4B

## 5. Cord Management

- A. With the back panel removed, connect the necessary monitor, keyboard, and mouse cords above the work surface.
- B. Position the keyboard as shown approximately 6" from the front edge of the work surface with the mouse on the opposite side of the CPU as shown. **Figure 5A**. This will provide enough slack in the cords during normal use and provide for left and right mouse locations. With a zip tie, secure cords to the back of the keyboard tray as shown.
- C. The wire loom keeps monitor and keyboard cords together and routes them while the monitor is being raised and lowered. Using a flat head screwdriver, pry open each loom clip to release the wire loom. **Figure 5B & 5C**.

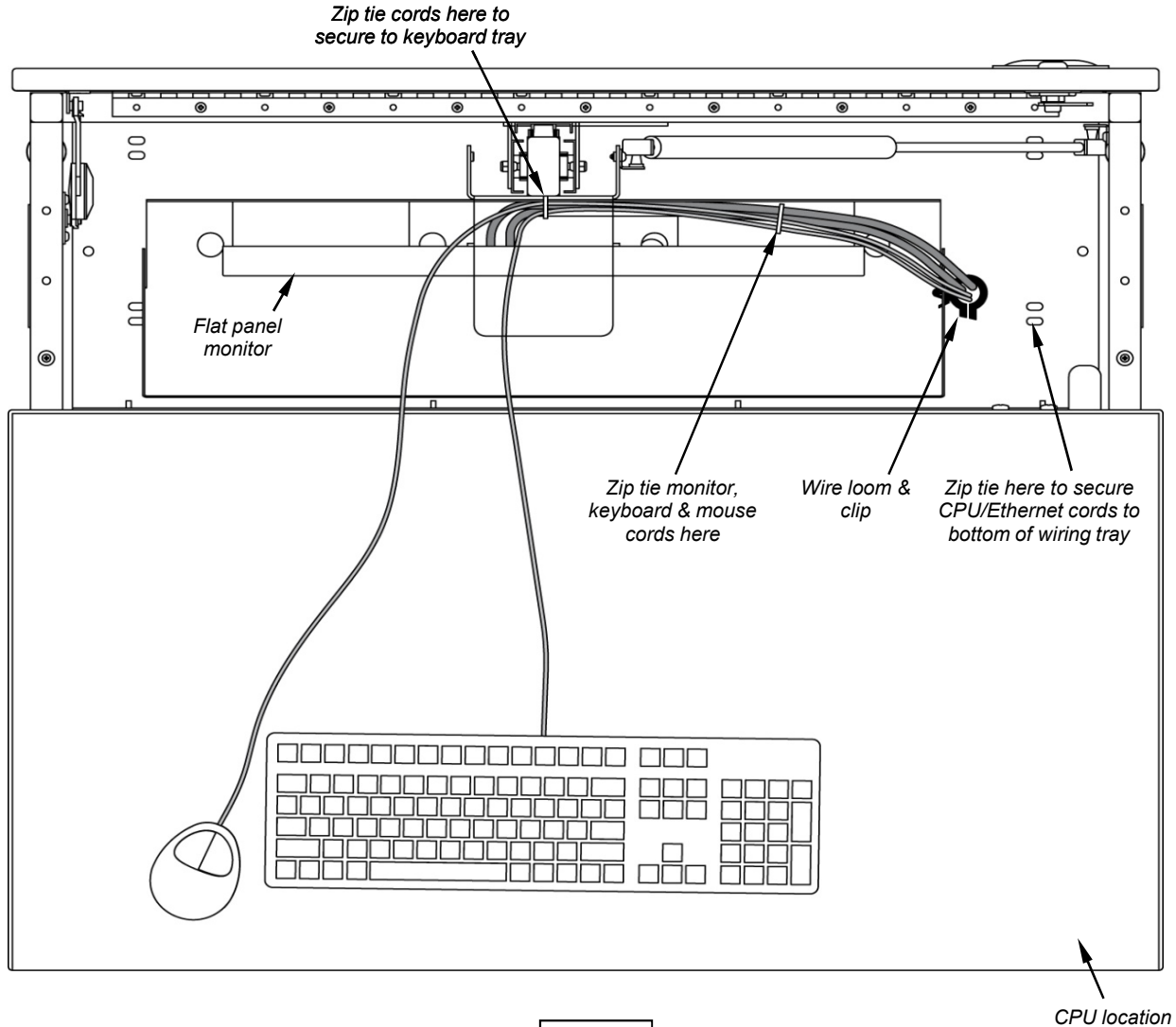

Figure 5A



Figure 5B



Figure 5C

- E. With the loom removed, feed the monitor, keyboard, and mouse cords through the sliced opening of the loom to the bottom of the desk as shown. **Figure 5D.**
- F. Split the CPU wires out of loom approximately 3/4 of the way down the loom and plug into CPU.
- G. Reattach the loom with the clips while providing enough slack in the loom to allow the monitor column to fully extend and retract.
- H. Secure the CPU cords to the bottom of the loom by attaching a zip tie around the loom directly above where the CPU cords exit the loom. This will prevent the cords from backing out of the loom. **Figure 5D.**
- I. Secure the CPU/Ethernet cords to the bottom of the wiring tray with a zip tie.
- J. Use additional zip ties to secure other cords as needed.

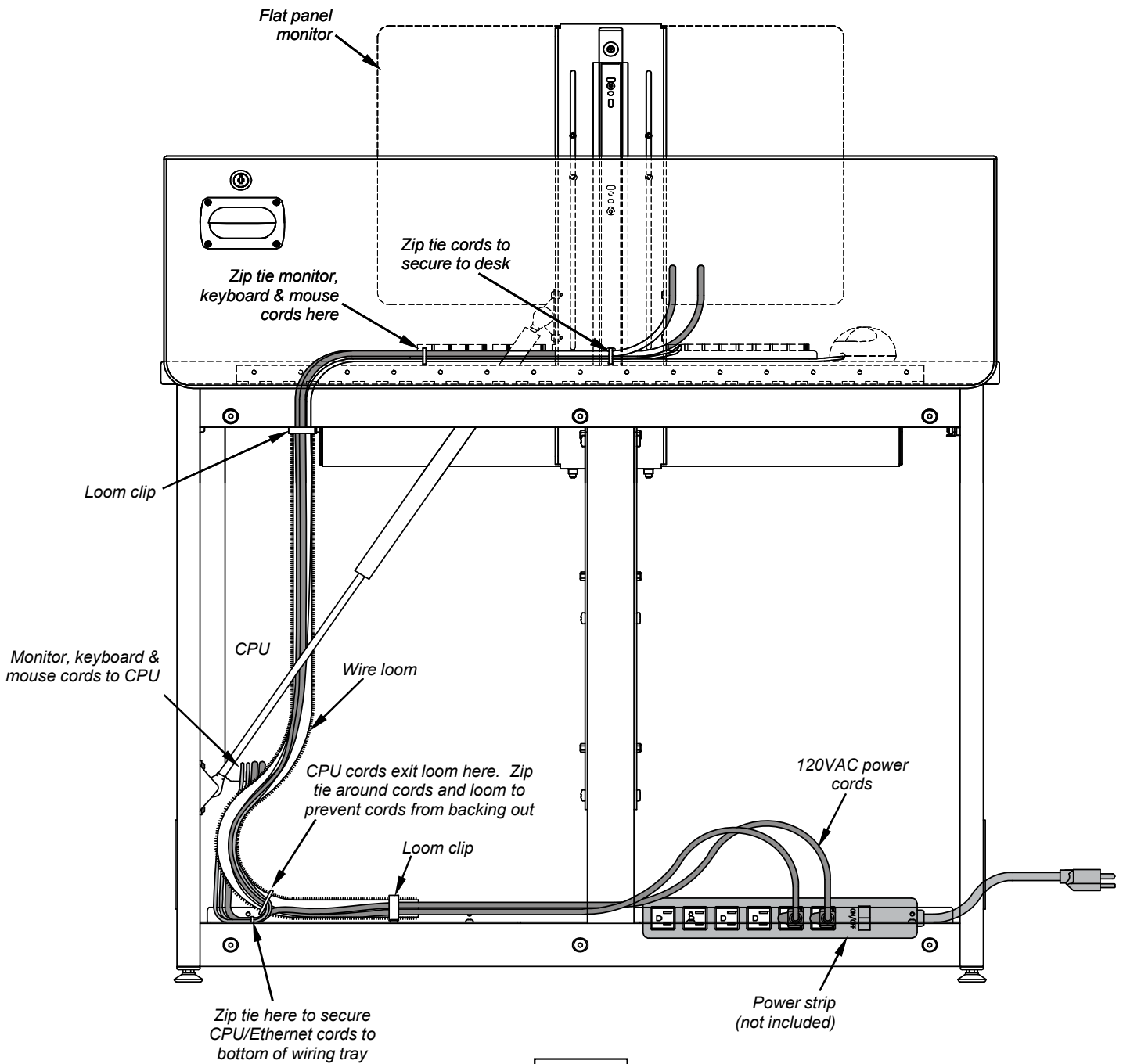

Figure 5D



## Operation

### **For computer use:**

Open the monitor compartment lid. Raise the monitor by pulling up on the lift bracket until fully extended. Take out the keyboard and mouse and set on the work surface.



### **For classroom (work surface) use:**

Place the keyboard and mouse in the compartment tray under the monitor. Lower the monitor by pushing down on the lift bracket until the column is fully retracted, then close the monitor compartment lid.

**Note:** Lockable desks can be locked at this point for security.

## Maintenance

- After approximately 300 cycles of opening and closing, the friction dampener on the work surface lid should be retightened to 13 in-lbs using a torque wrench with a 4mm hex driver. If a torque wrench is unavailable, tighten the friction damper with a 4mm hex wrench 1/8 turn at a time and test. The correct adjustment is when the lid slows down between 2-4" from closure. **Figure 6.**

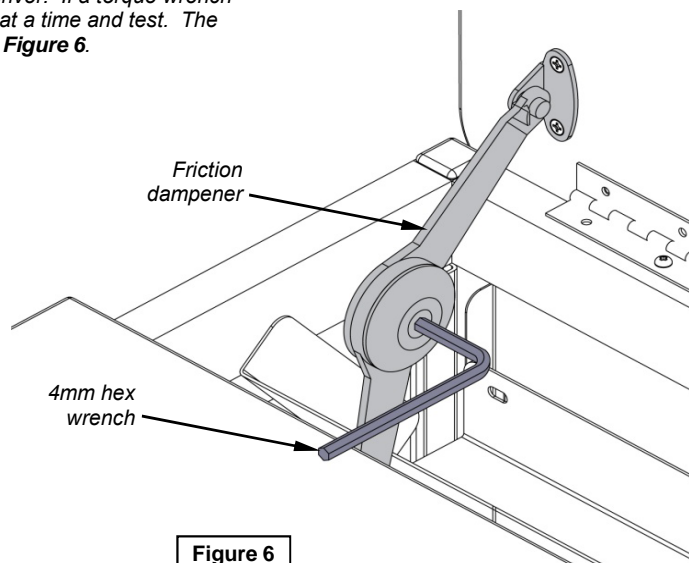

Figure 6

# Technical Specs

## Construction

- The top work surface is constructed from  $1\frac{1}{16}$ " thick industrial-grade composite board with .030 high-pressure laminate, and a balancing phenolic backer on the bottom side. The left, right, and rear edges are finished with 3mm vinyl edge-band.
- The monitor compartment lid work surface is constructed from  $\frac{3}{4}$ " thick industrial-grade composite board with .030 high-pressure laminate on both sides-all edges are finished with 3mm vinyl edge-band
- Heavy-duty metal components ranging from 12-20 gauge steel
- CPU sling has two deluxe 1" nylon straps with a locking buckle to secure CPU
- Welded, 16-gauge 1" x 2" rectangular steel tube legs
- Upper leg panel, 14 gauge
- Work surface edges are covered with 3mm vinyl
- All metal components are finished with a scratch-resistant powder coat epoxy paint
- Each Flex Insight Desk is factory-assembled, packaged and shipped on its own skid

## Capacity

- Overall dimensions:
  - Single: 36"W x 30"D x 29"H
  - Double: 72"W x 30"D x 29"H
  - Single ADA: 42"W x 30"D x 29"H
- Lift mechanism is manually actuated with pneumatic and spring-assist
- Lift capacity: factory preset for monitors weighing 7-14 lbs
- Maximum monitor size: 24"W x 16"H x 5-1/2"D
- CPU sling accommodates CPU's from 4"-8"W x up to 18"D x up to 18"H
- Wiring tray dimensions for power cords and power strips:
  - 36" single: 32"W x 9-3/4"D x 3-3/4"H
  - 72" double: 64"W x 9-3/4"D x 3-3/4"H
  - 42" ADA: 37-5/16"W x 9-3/4"D x 3-3/4"H
- Meets or exceeds all ANSI-BIFMA test standards
- Features and specifications subject to change without notice

### Unit weights (nominal):

- 36" single - 107 lbs
- 72" double - 194 lbs
- 42" ADA - 120 lbs

### Shipping weights (nominal):

- 36" single: 144 lbs
- 72" double: 266 lbs
- 42" ADA: 157 lbs

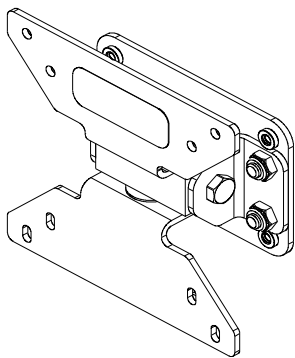

### Standard Swivel VESA Monitor Mount w/ internal travel stops

provides 4-direction tilt (4 left, 4 right, 16 up, and 6 down.) Works with 75mm and 100mm VESA monitor mounts (includes mounting screws)

**Note:** Specific monitor size, shape, & mounting location will determine exact angles of tilt.

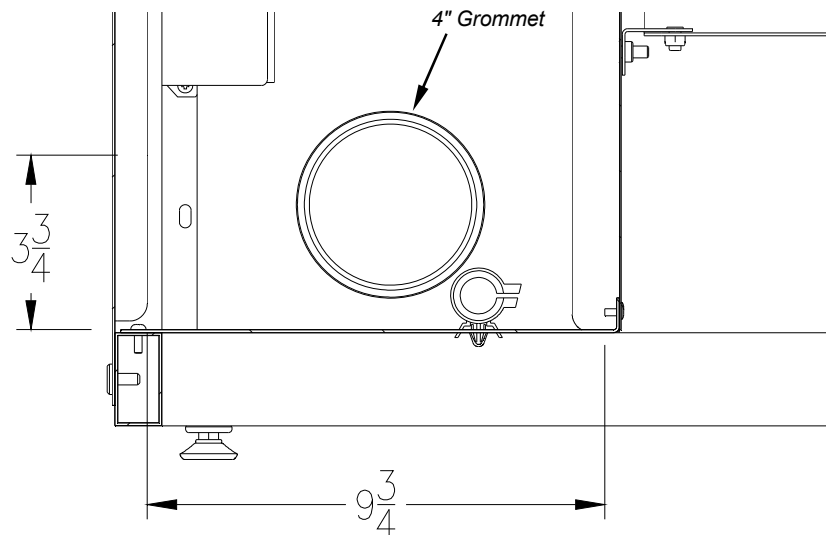

Wiring Tray  
Section View



**38958**  
**36" Single Desk w/ locking lid**

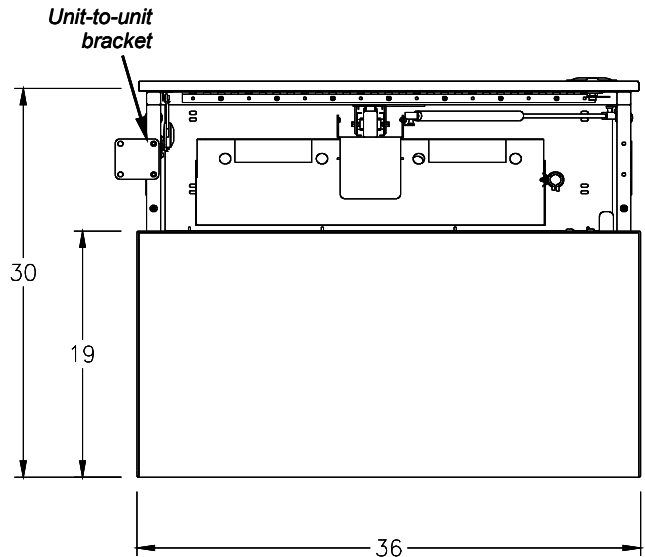
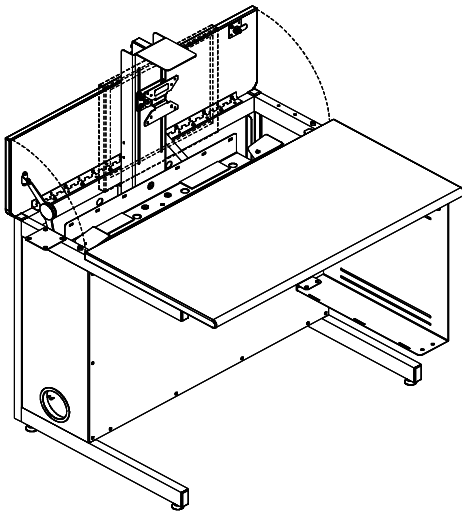

*Top View*

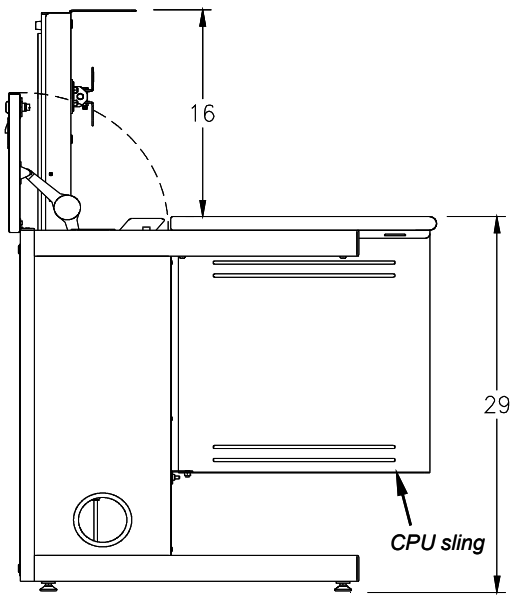

*Left-Side View*

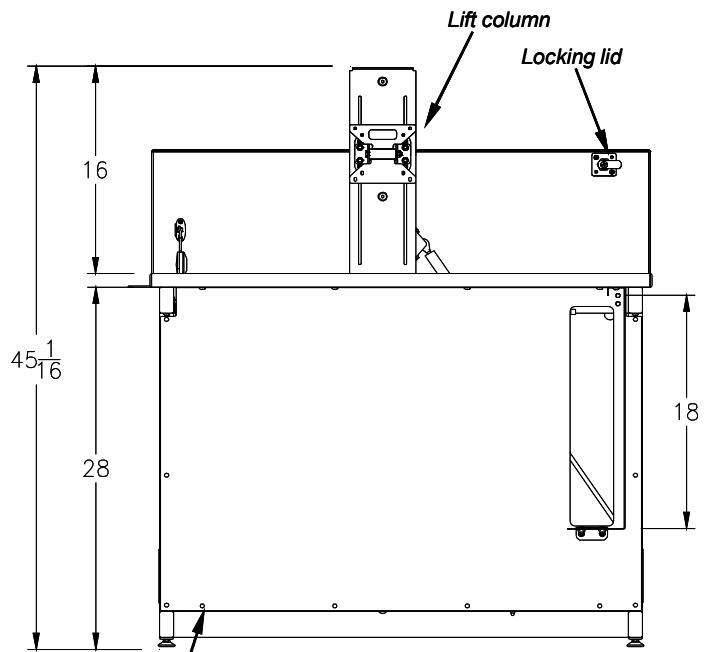

*Monitor compartment*

*Student-Side View*

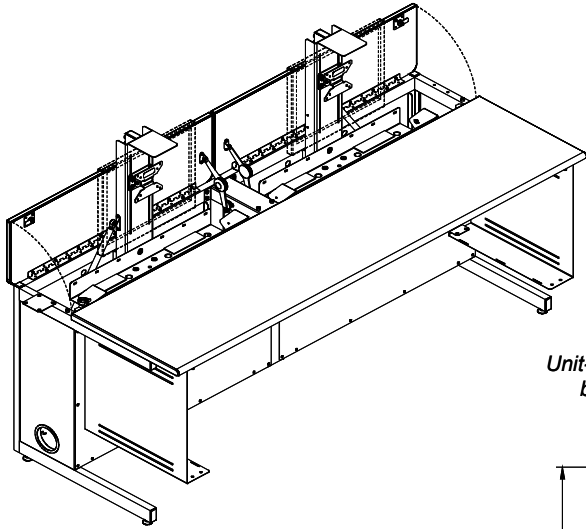

**38960**  
**72" Double Desk w/ locking lid**

Unit-to-unit  
bracket

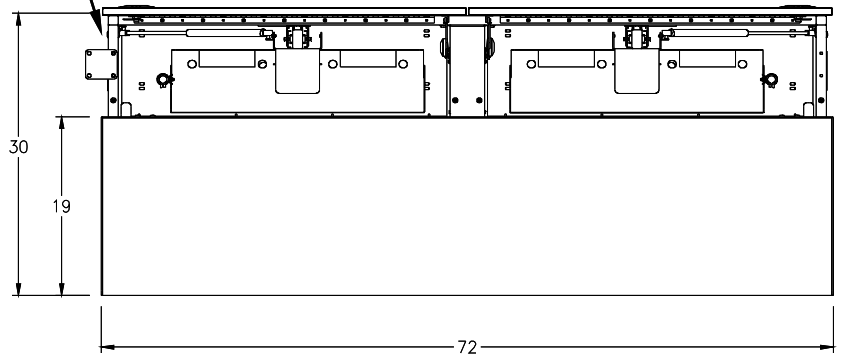

Top View

Locking Lid

Lift columns

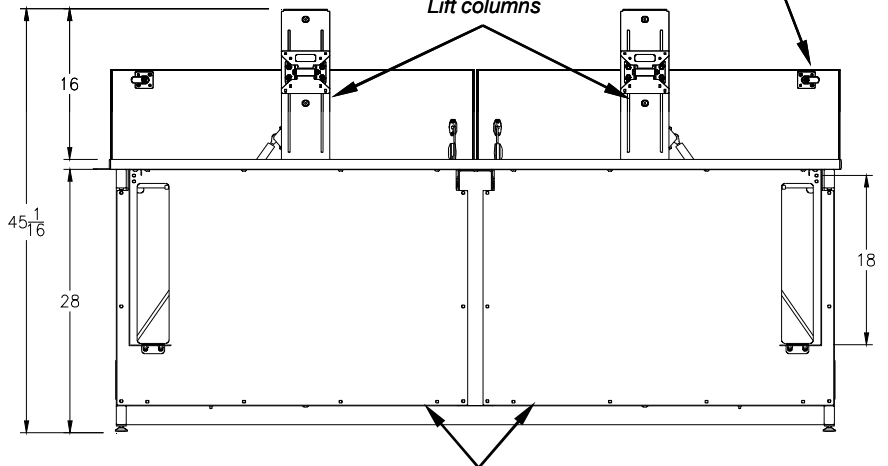

Monitor  
compartments

Student-Side View

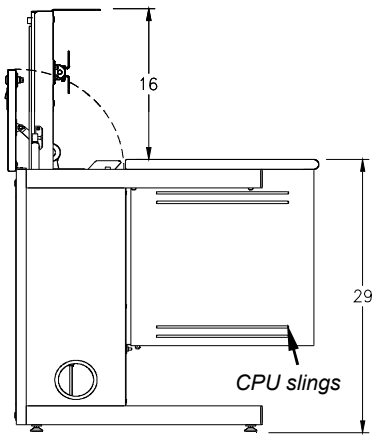

CPU slings

Left-Side View

**38959**  
**42" Single ADA Desk w/ locking lid**

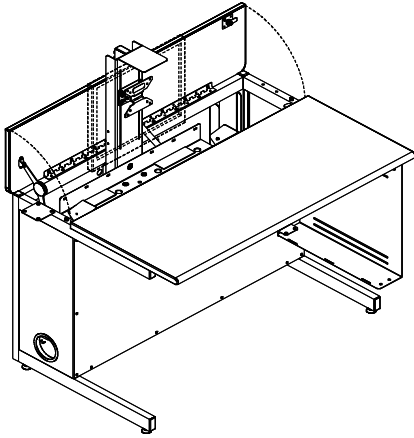

**Note:** The 42" Single ADA desk provides over 30" of leg width, 19" of leg depth, and over 27" of leg height to meet/exceed ADA requirements.

Unit-to-unit bracket

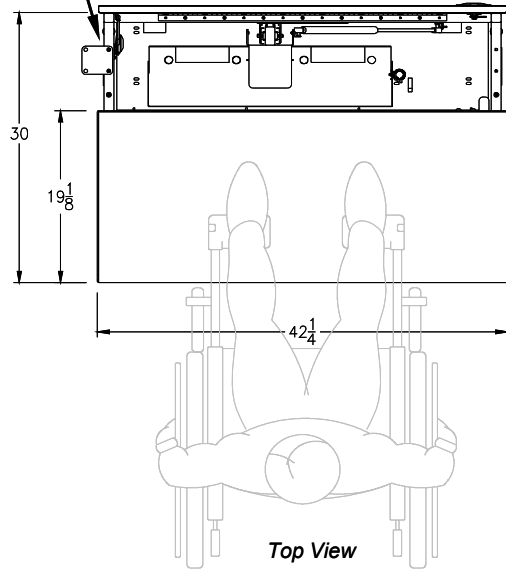

Top View

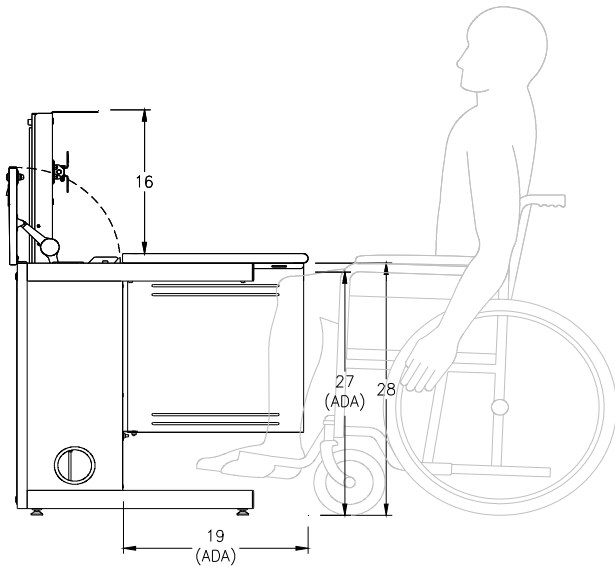

Left-Side View

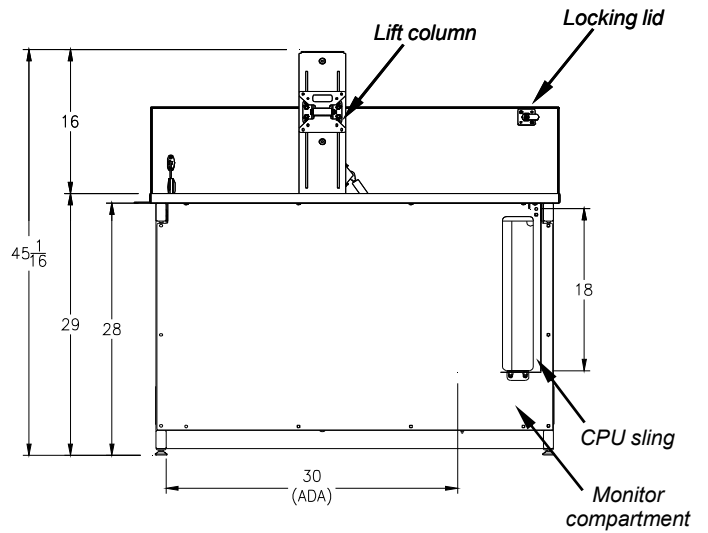

Student-Side View

**Flex Insight Desk Options**

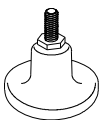

**1" Bell Glide Riser Kit**  
 raises work surface height from  
 29" to 30" (set of 4)  
 98513

## Warranty

### **WE WILL MAKE IT RIGHT FOR YOU!**

We guarantee all Spectrum products to be free of all defects in materials and workmanship, for the original owner, for a period of **ten years**. Any item deemed defective by Spectrum or the original manufacturer, under normal use conditions, will be repaired or replaced at Spectrum's discretion. This warranty applies to all products manufactured and distributed by Spectrum except the products listed below.

**DESIGNED FOR INDOOR USE ONLY** - Spectrum's products have been designed and constructed for indoor use only. Moving or using outdoors, or on excessively rough surfaces, may cause damage to the products and may void the warranty. If an outdoor application is desired please contact us to discuss potential custom design solutions.

Spectrum is committed to provide complete customer satisfaction. Each of our products are manufactured from the best materials available and each product is stringently monitored throughout the production process through our P.A.C.E. program (Product Assurance to meet Customer Expectations).

Our Customer Service Help Line 1-800-235-1262 is ready to provide immediate attention to any questions, comments or concerns. We are available to answer your calls Monday through Friday from 7 am to 5 pm CST. In addition your product comments or concerns are welcome via e-mail at: [spectrum@spectrumfurniture.com](mailto:spectrum@spectrumfurniture.com).

Items that have a varying warranty include, but are not limited to, the following:

- Adjustable Crank/Electric Desk Legs (1 yr)
- Flat Panel Desk Gas Cylinders (1 yr)
- Adjustable Height Chair Parts – including frames, gas cylinders, wood and plastic parts, and control handles (7 yrs)
- Adjustable Height Chair Parts Casters (2 yrs)
- Adjustable Height Chair Upholstery - In-Stock Upholstery (2 yrs)
- Adjustable Height Chair Upholstery - Graded-In Fabrics and C.O.M (no warranty)
- Height Adjustable Columns and Lifts (1 yr)
- General Use Casters (1 yr)
- Electrical – ECA (1 yr)
- Electrical - Power Strips (1 yr)
- Electrical Surge Suppressors (lifetime)
- Electrical - Retractable Power Cords (1 yr)
- Keyboard/Mouse Trays (1 yr)
- Flat Panel Monitor Arm – General Parts (5 yrs)
- Flat Panel Monitor Arm – Gas Cylinders (2 yrs)
- CRT Monitor Arm (1 yr)

The warranty, as stated above, is effective as of 05/28/2009



SCIENTIFIC CERTIFICATION SYSTEMS  
SCS-IAQ-02353

# Touchboards

205 Westwood Ave, Long Branch, NJ 07740  
Phone: 866-94 BOARDS (26273) / (732)-222-1511  
Fax: (732)-222-7088 | E-mail: [sales@touchboards.com](mailto:sales@touchboards.com)



**SPECTRUM**  
INDUSTRIES INC.

925 First Avenue, PO Box 400, Chippewa Falls, WI 54729 Ph: 1-800-235-1262 Fax: 1-800-335-0473

E-mail: [spectrum@spectrumfurniture.com](mailto:spectrum@spectrumfurniture.com) web: [www.spectrumfurniture.com](http://www.spectrumfurniture.com)