

Technical Specifications

See table matrix on p.3 for product numbers, shapes, and configurations

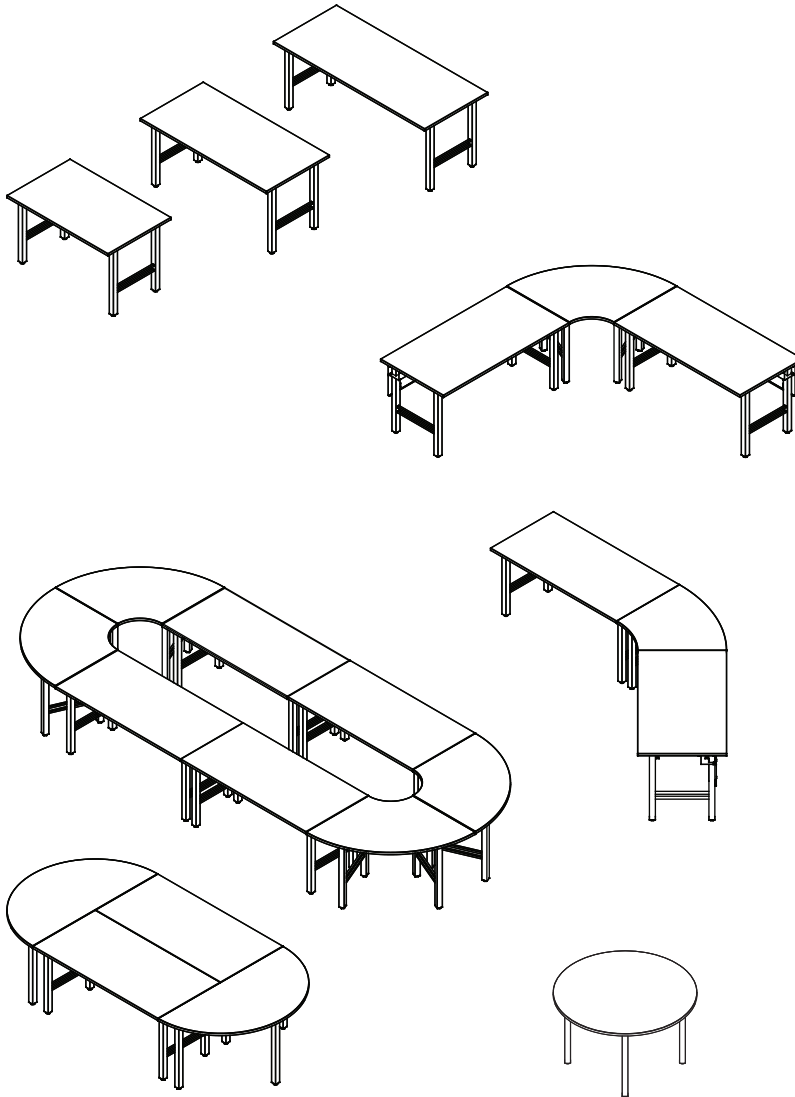

205 Westwood Ave, Long Branch, NJ 07740
Phone: 866-94 BOARDS (26273) / (732)-222-1511
Fax: (732)-222-7088 | E-mail: sales@touchboards.com

Size Options

- 72", 60", 48"W
- 30", 24"D

Leg Options

- 4 glides
- 2 glides / 2 casters
- 4 casters

Options & Accessories

Page 10

Color Options

Standard laminate / color combinations

Wild Cherry / Black
(CHB)



Indigo Organix / Black
(IB)



Indigo Organix / Dark Gray
(ID)



Indigo Organix / Silver Sparkle
(IS)



Bannister Oak / Putty
(KP)



Fusion Maple / Black
(FMB)



Fusion Maple / Silver Sparkle
(FMS)



Spectrum's Flex Training Table System is the best value in modular table systems. These durable, all-purpose collaborative/training tables are designed for use in a wide variety of applications such as training/conference rooms, mailrooms, classrooms, and computer labs. With the wide variety of available table shapes and sizes, layout possibilities are endless.

Features and Benefits

- Available in a wide variety of sizes and depths
- Durable powder coated steel legs
- Scratch and impact-resistant 1 $\frac{1}{8}$ " high-pressure laminate worksurface
- Durable 3mm black edge band protects worksurface edges
- Worksurface brace incorporated into all tables to minimize flexing
- Leveling glides keep desk level on uneven surfaces
- Mobile versions with two or four casters make it a breeze to rearrange rooms
- Unit-to-unit brackets included to attach tables together if necessary (set of two included with each table)
- Wide variety of standard color combinations available to match existing desks
- Optional cord channel manages cables and wires when tables are used with laptops
- Optional modesty panel can be used with or without cord channel
- Warranted to be free of all defects in materials and workmanship with a 10-year warranty

Standard color combination refers to the quickest deliverable product color combination. Custom laminates and color combinations are available-additional lead-times and up-charges may apply. Call 1-800-235-1262 for further information.

Construction

- The worksurface is constructed from 1/16" thick NAUF (no added urea formaldehyde) composite board with .030 high-pressure laminate on one face, and a balancing phenolic backer on the opposing face
- Worksurface edges are covered with 3mm vinyl
- The welded legs are 16-gauge, 2" and 3/4" rectangular steel tubing with reinforcing 7-gauge steel plate
- The formed worksurface brace is 14-gauge steel
- The optional cord channel and modesty panel are 20-gauge steel
- All metal components are finished with a scratch-resistant powder coat epoxy
- All tables are shipped knocked-down (KD) and require assembly



Note: Minimum ADA guidelines for knee clearances are 30"W x 19"D x 27"H.

Specifications

Widths available	72"W, 60"W, 48"W	
Depths available	24"D or 30"D	
Standard height	29"H	
2 3/8" casters	weight capacity 100 lbs each	
Seating	48"W - 1 person 60"W - 2 people 72"W - 2 people	1/8 round - 1 person 1/4 round - 1 person 1/2 round - 2 people
Optional cord channel	2 1/2"D x 3 1/2"H (available in all three widths)	
Optional modesty panel	9"H (available in all three widths)	
Shipping weights (nominal)	see table matrix	
Meets or exceeds applicable ANSI-BIFMA test standards		

Note: Optional cord channels & modesty panels fit straight tables only.

Specifications subject to change without notice

Leg Options

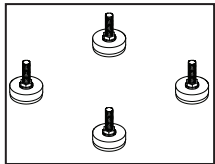

4 glides

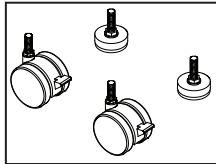

2 glides / 2 casters

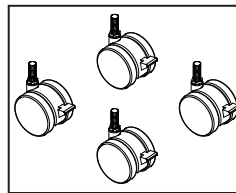

4 casters

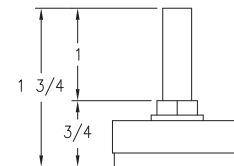
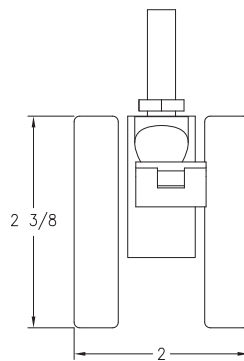
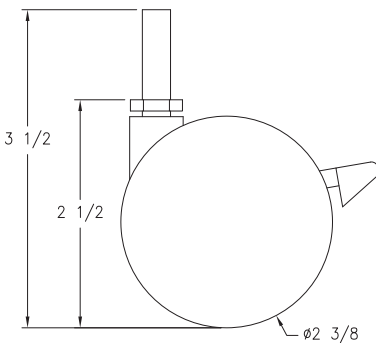

Note: Casters are made of "soft rubberized" plastic and are only used with shorter legs designed specifically for casters. They cannot be used with the taller "glide-only" leg style.

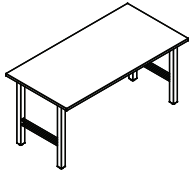



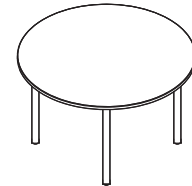
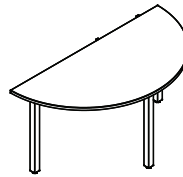
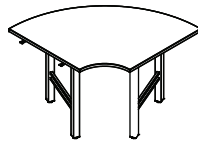

Flex Training Table Matrix

Product #	Shipping weight (lbs)	Worksurface					Leg options		
		Width			Depth		glides	2 glides / 2 casters	casters
		48"	60"	72"	24"	30"			
37259	77	✓			✓		✓		
37260	88		✓		✓		✓		
37261	99			✓	✓		✓		
37265	77	✓			✓			✓	
37266	88		✓		✓			✓	
37267	99			✓	✓			✓	
37271	77	✓			✓				✓
37272	88		✓		✓				✓
37273	99			✓	✓				✓
37262	88	✓				✓	✓		
37263	99		✓			✓	✓		
37264	110			✓		✓	✓		
37268	88	✓				✓		✓	
37269	99		✓			✓		✓	
37270	110			✓		✓		✓	
37274	88	✓				✓			✓
37275	99		✓			✓			✓
37276	110			✓		✓			✓



Additional Table Shapes

Product #	Shipping weight (lbs)	Worksurface				Depth		Leg options
		 1/8	 1/4	 1/2		Depth		glides
						24"	30"	
37295	61	✓				✓		✓
37296	64		✓			✓		✓
37297	67	✓					✓	✓
37298	74		✓				✓	✓
37251	62			✓		✓		✓
37252	74			✓			✓	✓
37250	85				✓	48" Dia		✓

30"D rectangular Training Table
(shown with optional cord channel & modesty panel)

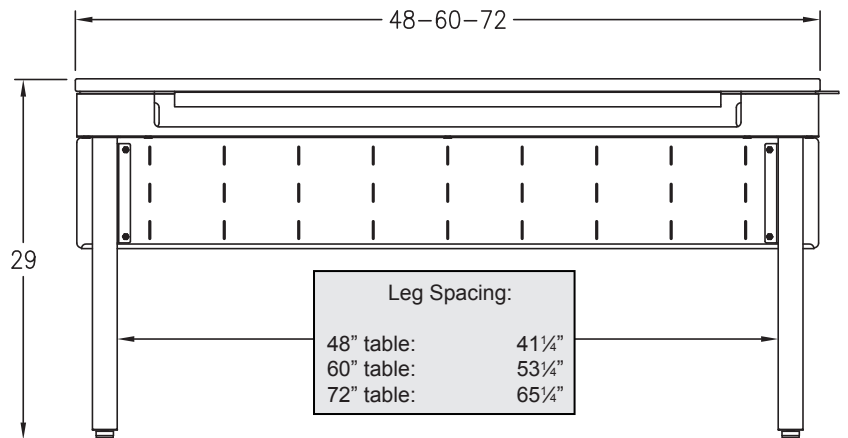
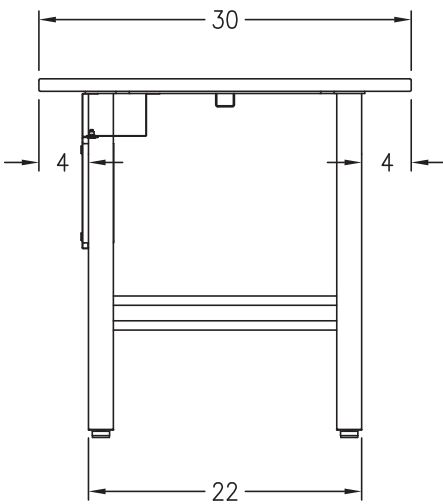
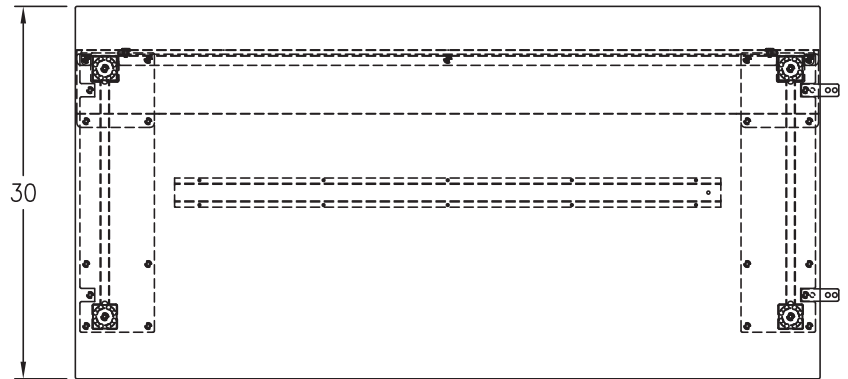
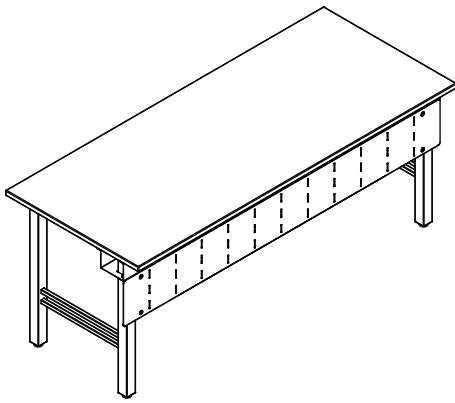

Note: 48"W tables are not wide enough for two people in most situations. Spectrum recommends at least a 60"W table when accommodating two people.

24"D rectangular Training Table
 (shown with optional cord channel & modesty panel)

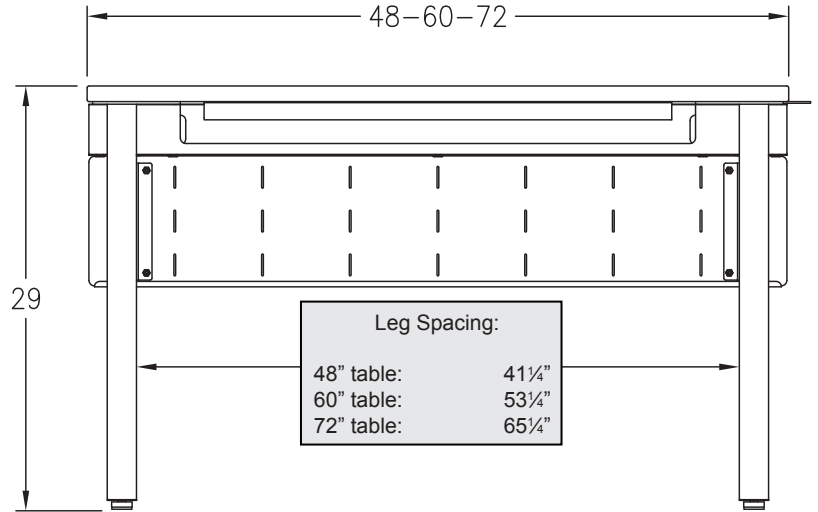
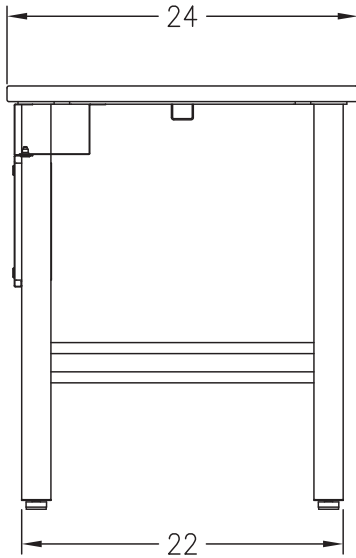
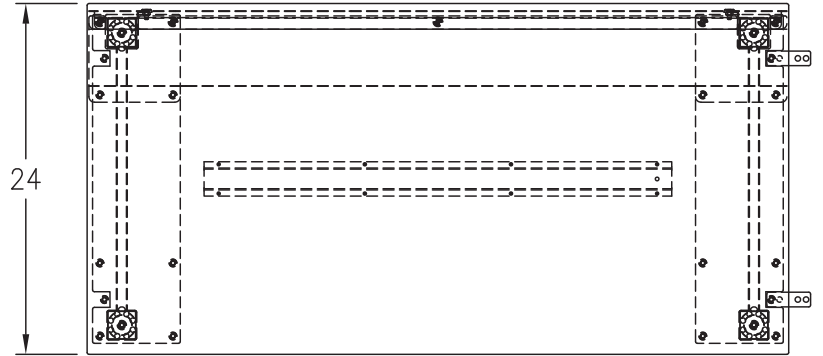
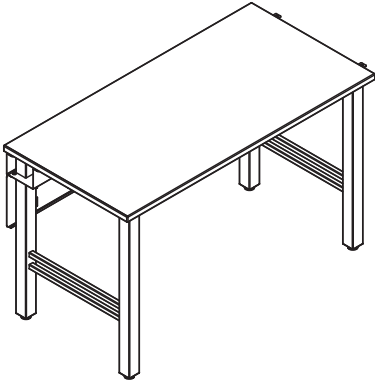

Note: 48"W tables are not wide enough for two people in most situations. Spectrum recommends at least a 60"W table when accommodating two people.

1/2 round Training Table - 60" dia
 37252
 (use with 30"D tables)

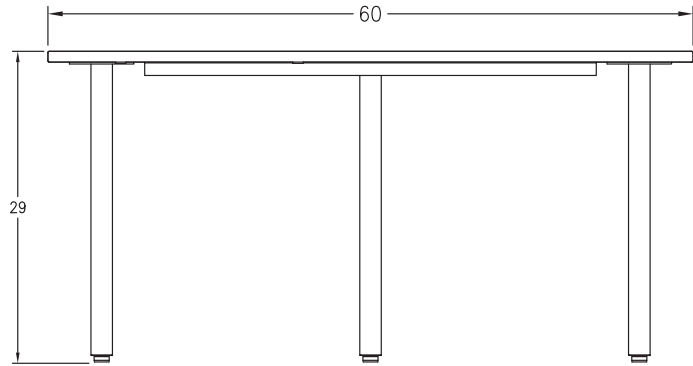
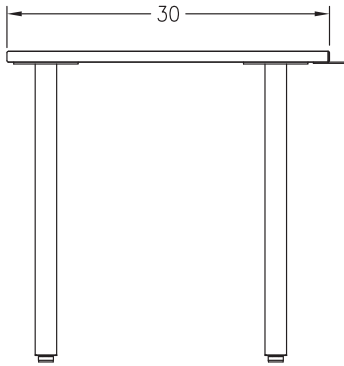
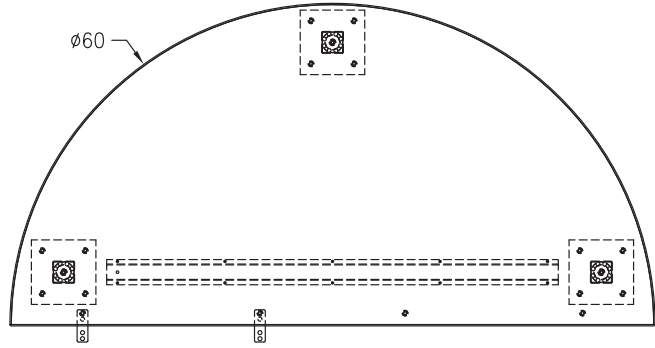
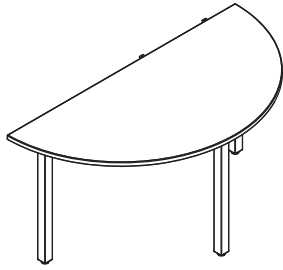

1/2 round Training Table - 48" dia
 37251
 (use with 24"D tables)

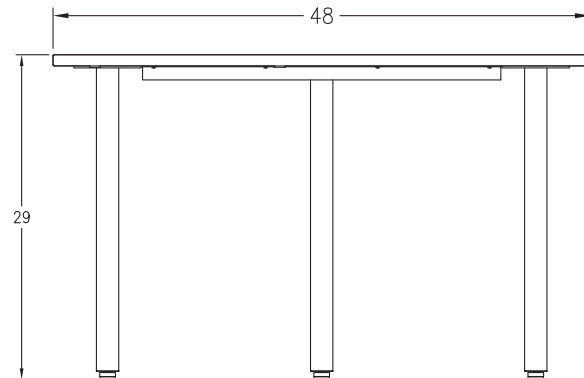
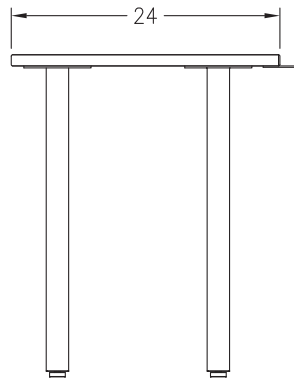
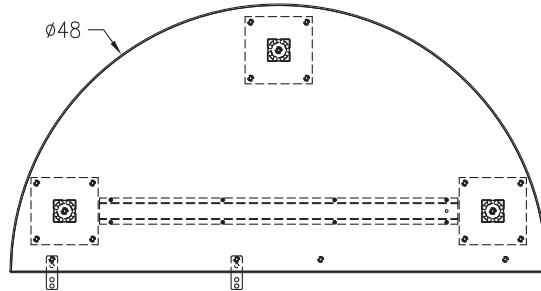
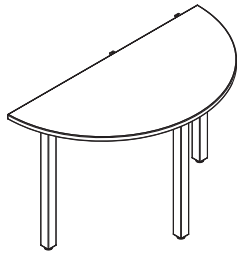

1/4 round Training Table (30"D)
37298

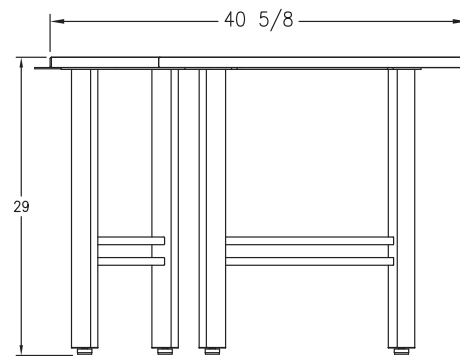
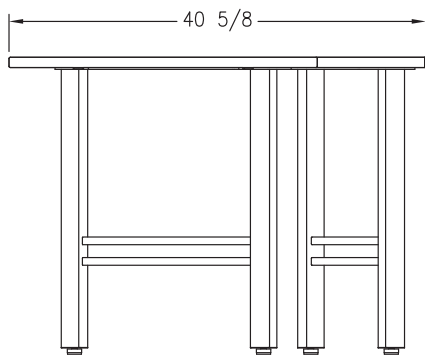
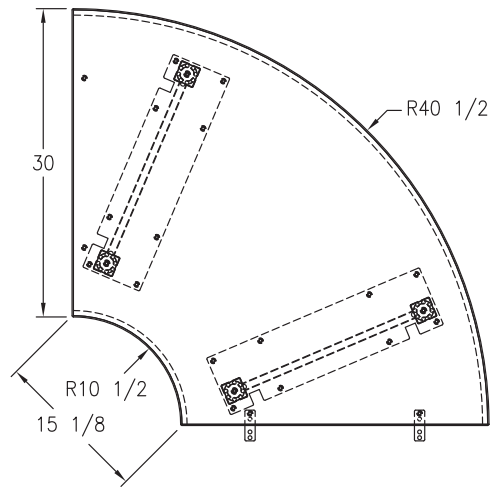
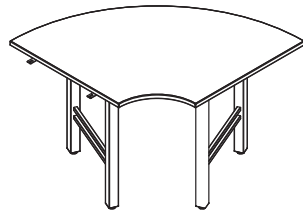

1/4 round Training Table (24"D)
37296

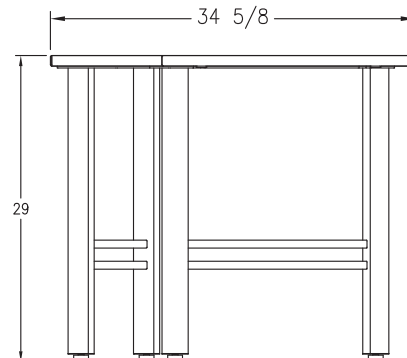
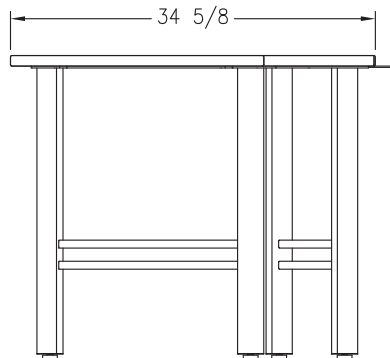
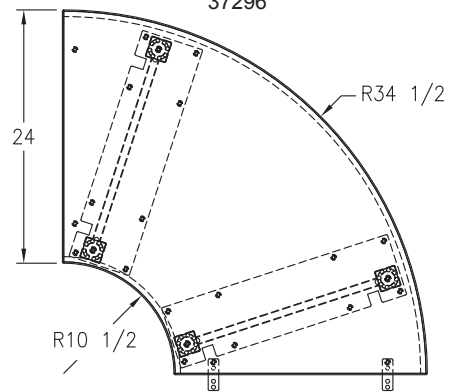
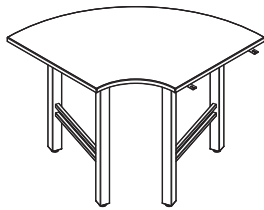

1/8 round Training Table (30"D)
37297

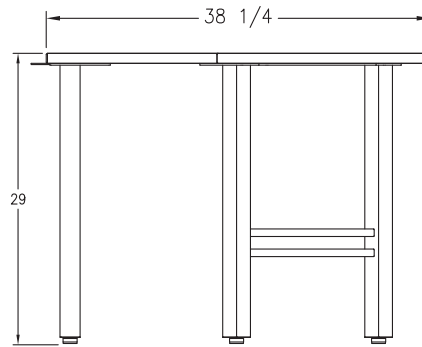
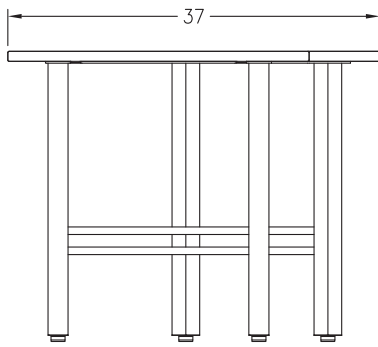
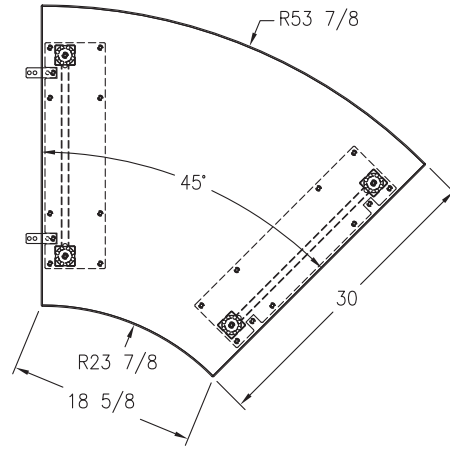
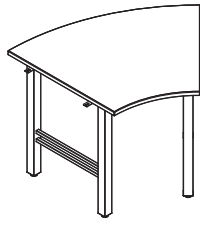

1/8 round Training Table (24"D)
37295

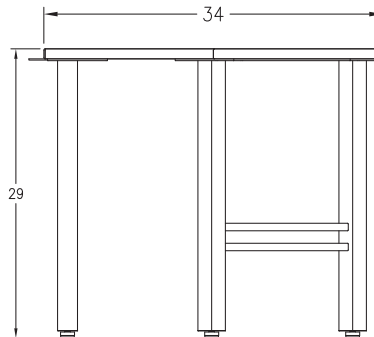
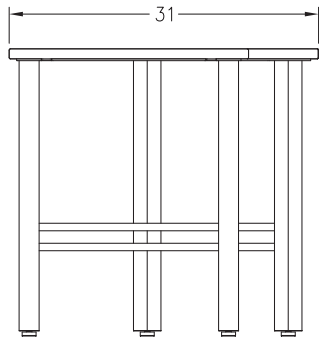
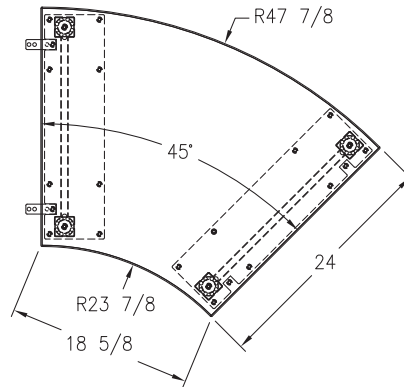
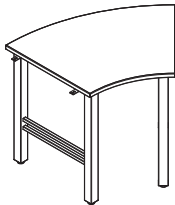

Round Training Table (48" Dia)
37250

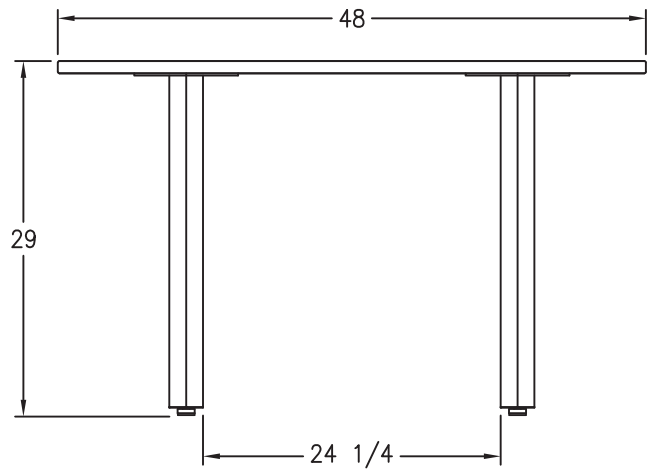
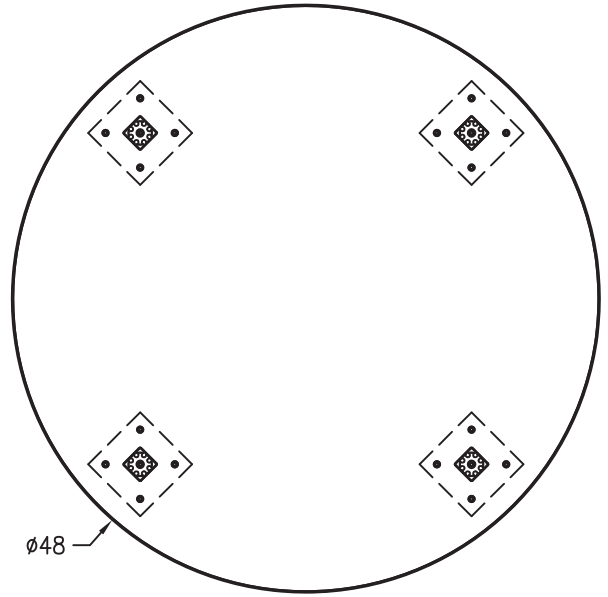
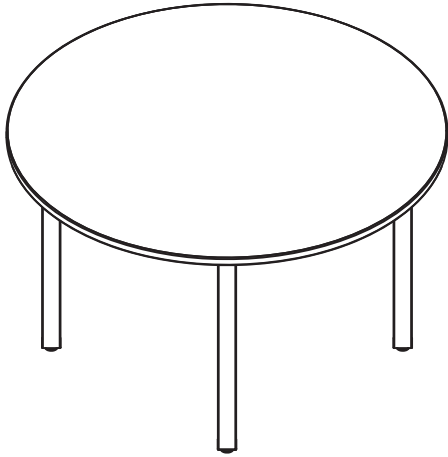

Options

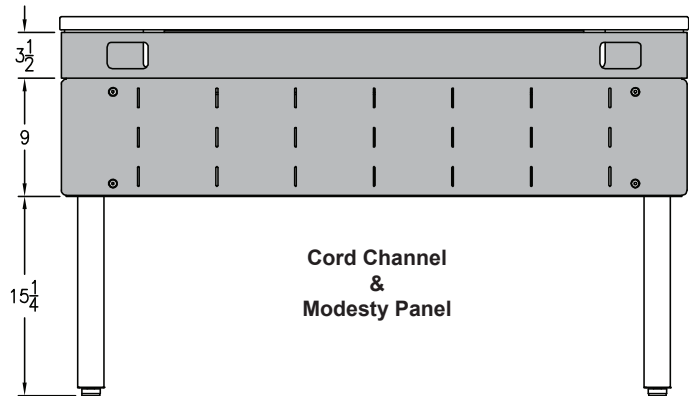
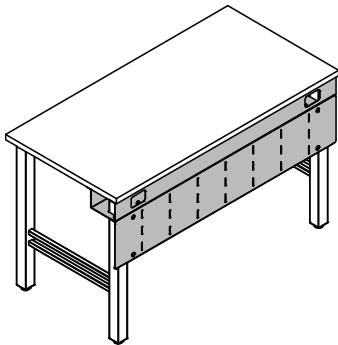
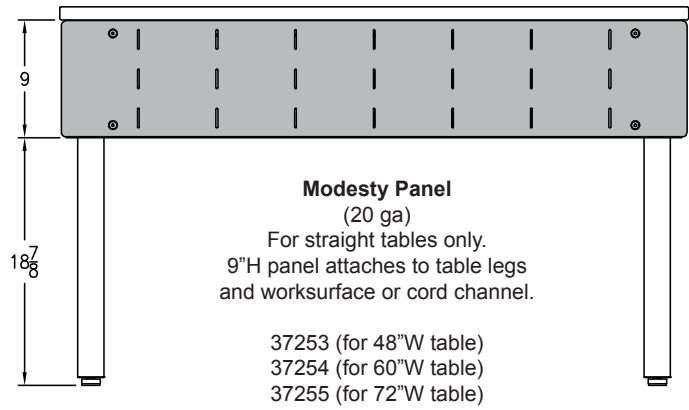
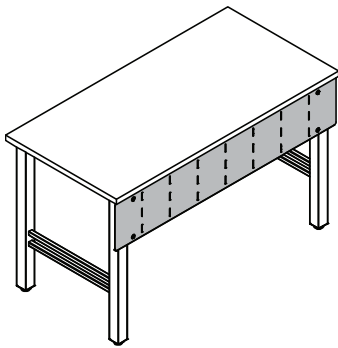
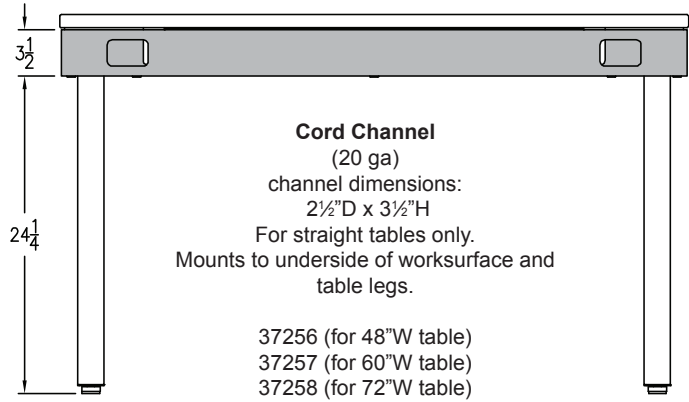
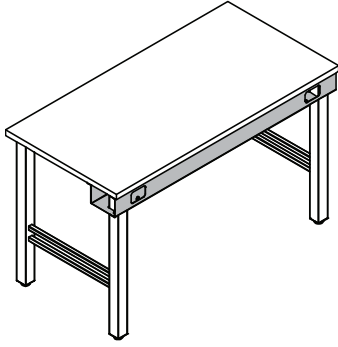

Warranty

WE WILL MAKE IT RIGHT FOR YOU!

Spectrum is committed to provide complete customer satisfaction. Each of our products are manufactured from the best materials available and each product is stringently monitored throughout the production process through our P.A.C.E. program (Product Assurance to meet Customer Expectations). Our Customer Service Help Line 1-800-235-1262 is ready to provide immediate attention to any questions, comments or concerns. We are available to answer your calls Monday through Friday from 7 am to 5 pm CST, excluding observed holidays. In addition your product comments or concerns are welcome via e-mail at: spectrum@spectrumfurniture.com.

Warranty Statement

We guarantee all Spectrum products to be free of all defects in materials and workmanship, for the original owner, for a period of ten years. Any item deemed defective by Spectrum or the original manufacturer, under normal use conditions, will be repaired or replaced at Spectrum's discretion. This warranty applies to all products manufactured and distributed by Spectrum except the products listed below.

Items that have a varying warranty include, but are not limited to, the following:

- Adjustable Crank/Electric Desk Legs (1 yr)
- Flat Panel Desk Gas Cylinders (1 yr)
- Upholstered Soft-Goods (5 yrs)
- Adjustable Height & Stacking Chair Parts – including frames, gas cylinders, wood and plastic parts, and control handles (7 yrs)
- Adjustable Height & Stacking Chair Casters (2 yrs)
- Chair Upholstery & Textiles (2 yrs of normal use of Soft Goods, Adjustable Height, Stacking, Wood and Metal Chairs)
- Chair Upholstery - Graded-In Fabrics and C.O.M (no warranty)
- Height Adjustable Columns and Lifts (1 yr)
- General Use Casters (1 yr)
- Electrical – Electri-Pak, Power Communication Modules, and special order ECA electrical items (1 yr)
- Electrical - Power Strips & Electrical Timers (1 yr)
- Electrical Surge Suppressors (lifetime)
- Electrical - Retractable Power Cords (1 yr)
- Keyboard/Mouse Trays (1 yr)
- Flat Panel Monitor Arm – General Parts (5 yrs)
- Flat Panel Monitor Arm – Gas Cylinders (2 yrs)
- CRT Monitor Arm (1 yr)

Warranty is void if product is not used for its intended purpose or subjected to an unusual application, multiple-shift use, alteration, accident, abuse or abnormal wear and tear. Representations of colors on-line and in printed materials are meant to be a close reference to the actual colors but not an exact match. Slight variations in color and texture of wood stains, powder coating, laminates, fabrics and other materials are normal in different manufacturing lots; as such these variations are not considered defects.

DESIGNED FOR INDOOR USE ONLY – Unless specifically stated in the product specifications, Spectrum's products have been designed and constructed for indoor use only. Moving or using outdoors, or on excessively rough surfaces, may cause damage to the products and will void the warranty. If an outdoor application is desired please contact us to discuss potential custom design solutions.

The warranty, as stated above, supersedes any previous warranties and is effective as of 9/1/2010

Touchboards

205 Westwood Ave, Long Branch, NJ 07740
Phone: 866-94 BOARDS (26273) / (732)-222-1511
Fax: (732)-222-7088 | E-mail: sales@touchboards.com

