

# Assembly Instructions:

To purchase parts or accessories, please contact us at  
[www.spectrumfurniture.com](http://www.spectrumfurniture.com)  
 1-800-235-1262  
 Thank you for choosing Spectrum products!

037779 0101909  
 5/16-18 Glide 5/16-18 Caster

**Note:** Flex Training Tables come with glides and/or casters in any of these combinations

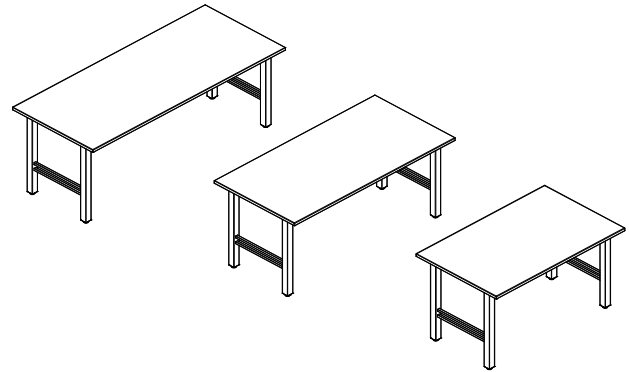
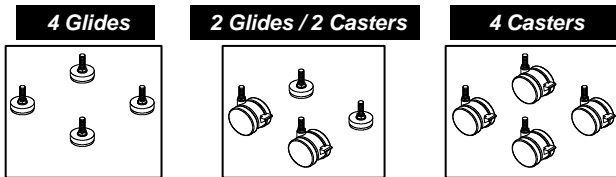

## Flex Training Tables (24" and 30" deep) 372XX

(20) 026064 1/4-20 x 5/8" PHMS  
 (4) 0103920 1/4-20 x 1/2" Thumbscrews  
 (2) 037749 Unit-to-unit brackets  
 (1) 025069 Caster/Glide wrench

**Tools Required:**  
 Phillips screwdriver  
 Caster / Glide wrench (included)

Before you begin, please make sure all parts and proper quantities are included. Any parts damaged during shipment must be reported within 15 days of receipt. To report information regarding damages or if you have any questions, please call 1-800-235-1262.



## 1. Table Assembly

- Place work surface face-down onto a non-abrasive surface.
- Attach the legs to the work surface using 1/4-20 x 5/8" PHM screws and tighten securely. **Figure 1.**
- Attach the casters and/or glides to the legs. Glides attach to the longer 28" tall legs, and casters will attach to the shorter 27" tall legs. Tighten securely with caster/glide wrench.
- If tables are to be connected together, attach the unit-to-unit brackets as shown in **Figure 1A.**
- Carefully flip the table upright-this may require two people.

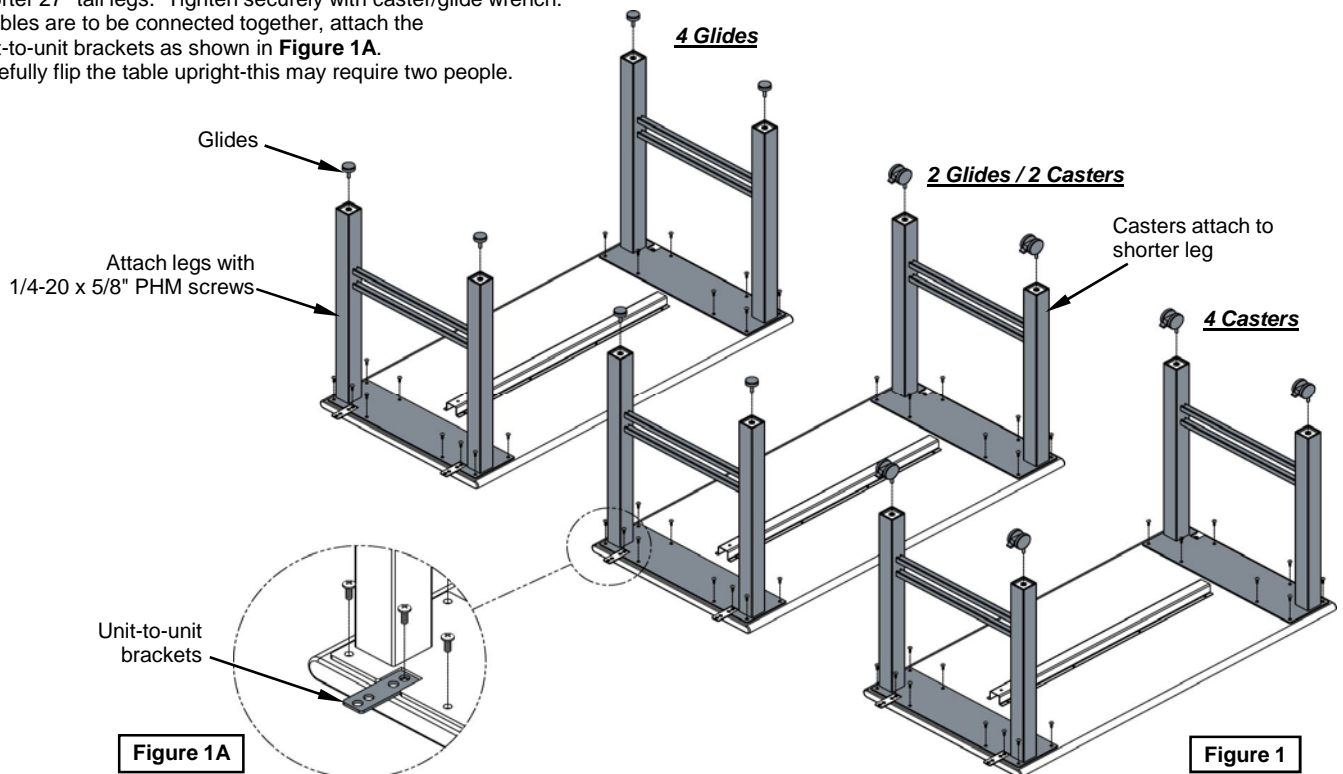

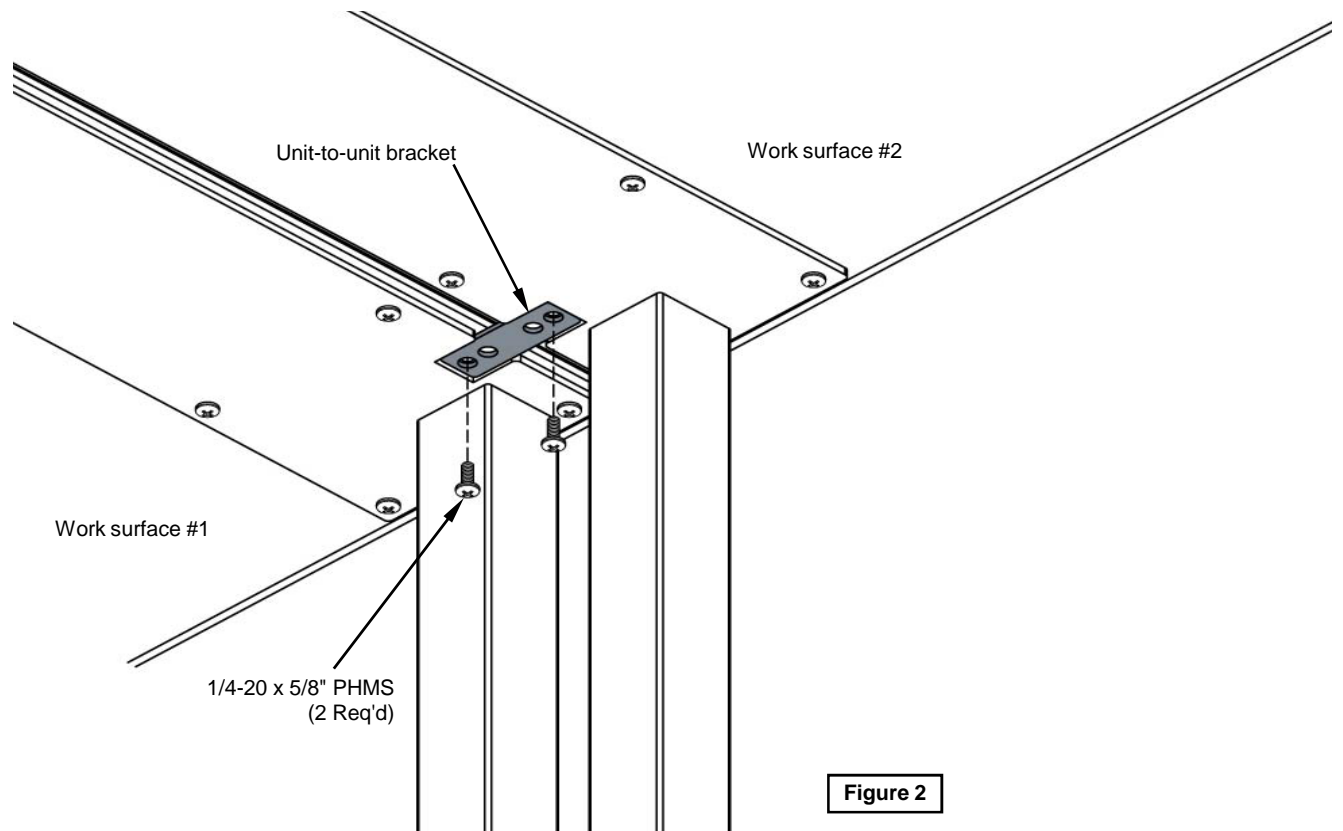

Figure 2

## 2. Connecting tables together (optional)

- A. Arrange the tables side-to-side in the preferred location.
- B. Attach the unit-to-unit brackets to both table work surfaces as shown with 1/4-20 x 5/8" PHM screws and tighten securely. **Figure 2.**

**Note:** If a more temporary arrangement is preferred, the easily removable 1/4-20 thumbscrews can be used on the unit-to-unit brackets instead of Phillips Screws.

## 3. Moving tables

- A. If moving a table with the glide/caster combination, unlock the casters, and pick the table up from the glide-side and move.
- B. Be sure to lock all casters after moving.

# Touchboards

205 Westwood Ave, Long Branch, NJ 07740  
 Phone: 866-94 BOARDS (26273) / (732)-222-1511  
 Fax: (732)-222-7088 | E-mail: sales@touchboards.com

**SPECTRUM**  
 INDUSTRIES INC.

925 First Avenue, PO Box 400, Chippewa Falls, WI 54729 Ph: 1-800-235-1262 Fax: 1-800-335-0473  
 E-mail: spectrum@spectrumfurniture.com web: www.spectrumfurniture.com