

1750

Power Recorder

Calibration Manual

November 2007 Rev. 1, 12/08

© 2007-2008 Fuke Corporation, All rights reserved. Product specifications are subject to change without notice.
All product names are trademarks of their respective companies.

LIMITED WARRANTY AND LIMITATION OF LIABILITY

Each Fluke product is warranted to be free from defects in material and workmanship under normal use and service. The warranty period is one year and begins on the date of shipment. Parts, product repairs, and services are warranted for 90 days. This warranty extends only to the original buyer or end-user customer of a Fluke authorized reseller, and does not apply to fuses, disposable batteries, or to any product which, in Fluke's opinion, has been misused, altered, neglected, contaminated, or damaged by accident or abnormal conditions of operation or handling. Fluke warrants that software will operate substantially in accordance with its functional specifications for 90 days and that it has been properly recorded on non-defective media. Fluke does not warrant that software will be error free or operate without interruption.

Fluke authorized resellers shall extend this warranty on new and unused products to end-user customers only but have no authority to extend a greater or different warranty on behalf of Fluke. Warranty support is available only if product is purchased through a Fluke authorized sales outlet or Buyer has paid the applicable international price. Fluke reserves the right to invoice Buyer for importation costs of repair/replacement parts when product purchased in one country is submitted for repair in another country.

Fluke's warranty obligation is limited, at Fluke's option, to refund of the purchase price, free of charge repair, or replacement of a defective product which is returned to a Fluke authorized service center within the warranty period.

To obtain warranty service, contact your nearest Fluke authorized service center to obtain return authorization information, then send the product to that service center, with a description of the difficulty, postage and insurance prepaid (FOB Destination). Fluke assumes no risk for damage in transit. Following warranty repair, the product will be returned to Buyer, transportation prepaid (FOB Destination). If Fluke determines that failure was caused by neglect, misuse, contamination, alteration, accident, or abnormal condition of operation or handling, including overvoltage failures caused by use outside the product's specified rating, or normal wear and tear of mechanical components, Fluke will provide an estimate of repair costs and obtain authorization before commencing the work. Following repair, the product will be returned to the Buyer transportation prepaid and the Buyer will be billed for the repair and return transportation charges (FOB Shipping Point).

THIS WARRANTY IS BUYER'S SOLE AND EXCLUSIVE REMEDY AND IS IN LIEU OF ALL OTHER WARRANTIES, EXPRESS OR IMPLIED, INCLUDING BUT NOT LIMITED TO ANY IMPLIED WARRANTY OF MERCHANTABILITY OR FITNESS FOR A PARTICULAR PURPOSE. FLUKE SHALL NOT BE LIABLE FOR ANY SPECIAL, INDIRECT, INCIDENTAL, OR CONSEQUENTIAL DAMAGES OR LOSSES, INCLUDING LOSS OF DATA, ARISING FROM ANY CAUSE OR THEORY.

Since some countries or states do not allow limitation of the term of an implied warranty, or exclusion or limitation of incidental or consequential damages, the limitations and exclusions of this warranty may not apply to every buyer. If any provision of this Warranty is held invalid or unenforceable by a court or other decision-maker of competent jurisdiction, such holding will not affect the validity or enforceability of any other provision.

Fluke Corporation
P.O. Box 9090
Everett, WA 98206-9090
U.S.A.

Fluke Europe B.V.
P.O. Box 1186
5602 BD Eindhoven
The Netherlands

11/99

To register your product online, visit <http://register.fluke.com>

Table of Contents

Title	Page
Introduction.....	1
Contacting Fluke.....	1
Safety Information	2
Symbols	3
Specifications for the System: Recorder and Power Analyze Software	3
General Specifications.....	3
Input Specifications.....	3
Synchronization and Sampling.....	4
Voltage and Current Measurements	4
Voltage and Current Measurement Accuracy	4
Transient Voltage (Impulse).....	4
Dip (Sag) and Swell Measurements	4
Power and PF Measurement.....	5
External Interface Specifications.....	5
Environmental and Safety Specifications.....	6
Cleaning and Maintenance.....	6
Required Equipment	6
Verification Tests.....	8
AC Voltage Accuracy Verification	8
Neutral Voltage Verification	10
Rogowski Current Verification	10
CT Current Verification	11
Watt Verification.....	12
Impulse Verification.....	12
Calibration	14
Required Equipment.....	14
Calibration Adjustment	14
Test Cables.....	16

List of Tables

Table	Title	Page
1.	Symbols.....	3
2.	Required Equipment.....	6
3.	Required Cables	7
4.	AC Voltage Accuracy Verification	9
5.	Neutral (AC) Voltage Accuracy Check	10
6.	Rogowski Current Accuracy Check	11
7.	CT Current Accuracy Check	11
8.	Impulse Verification Inputs.....	14

List of Figures

Figure	Title	Page
1.	Power View Software Live View.....	9
2.	Ground Calibration Cable	16
3.	Rogowski Calibration Cable	17
4.	Rogowski Resistor Measurement Cable	18
5.	Voltage Calibration Cable.....	19
6.	Current Calibration Cable	20

1750 Power Recorder

Introduction

Warning

To avoid electric shock or personal injury, do not perform the calibration verification tests or calibration procedures described in this manual unless you are qualified to do so. The information provided in this manual is for the use of qualified personnel only.

The *1750 Calibration Manual* provides the following information:

- Precautions and safety information
- Specifications
- Basic maintenance
- Calibration procedures
- Verification procedures
- Replaceable parts and accessories

For complete operating instructions and calibration software, refer to the *1750 Users Manual CD*.

Contacting Fluke

To contact Fluke, call:

1-888-993-5853 in USA
1-800-363-5853 in Canada
+31-402-675-200 in Europe
+81-3-3434-0181 in Japan
+65-738-5655 in Singapore
+1-425-446-5500 from anywhere in the world

Or, visit Fluke's Web site at www.fluke.com

To register your product, visit <http://register.fluke.com>

To contact Technical Support:

fpqsupport@fluke.com

or 888-257-9897 (US only)

Safety Information

The 1750 Power Recorder (hereafter referred to as the Recorder) complies with EN 61010-1 600 V CAT IV, 1000 V CAT III overvoltage rating. See Specifications for a full agency compliance list.

⚠️⚠️ Warning







To avoid electrical shock, personal injury, or fire:

- **Review the entire manual before using the Recorder and its accessories and observe all warnings and cautions.**
- **Do not perform the calibration verification tests or calibration procedures described in this manual unless you are qualified to do so.**
- **Avoid working alone.**
- **Do not operate the Recorder around explosive gas or vapor.**
- **Use only insulated current probes, test leads, and adapters as supplied with the Recorder, or indicated as suitable for the Recorder.**
- **Before use, inspect the Recorder, voltage probes, current probes, leads, and accessories for mechanical damage, and replace when damaged. Look for cracks or missing plastic. Pay special attention to the insulation surrounding the connectors.**
- **Remove all probes, test leads, and accessories that are not in use.**
- **Make sure the Recorder is properly connected through the power cord to protective earth ground.**
- **Do not apply input voltages above the rating of the Recorder as shown on the input panel.**
- **Do not apply voltages in excess of the marked ratings of the voltage probes and current probes.**
- **Use caution if exposed metal BNC or banana plug connectors are used for calibration. Avoid applying voltage to the shell of the BNC during calibration.**
- **Do not insert metal objects into connectors.**
- **Never open the Recorder's enclosure, dangerous voltages are present. There are no user-replaceable parts in the Recorder. Refer servicing of internal parts to qualified service personnel.**
- **Use the Recorder only as specified in this manual, or the protection provided by the Recorder may be impaired.**

Symbols

Symbols used in this manual and on the Recorder are listed in Table 1.

Table 1. Symbols

	Hazardous voltage. Risk of electrical shock.		Risk of danger. Important information. See manual.
	Conforms to requirements of European Union and European Free Trade Association (EFTA).		Do not dispose of this product as unsorted municipal waste. Go to Fluke's web site for recycling information.
	Canadian Standards Association. [Note: Canadian and US.]		Protective conductor terminal.
CAT III	CAT III equipment is designed to protect against transients in equipment in fixed-equipment installations, such as distribution panels, feeders and short branch circuits, and lighting systems in large buildings.	CAT IV	CAT IV equipment is designed to protect against transients from the primary supply level, such as an electricity meter or an overhead or underground utility service.

Specifications for the System: Recorder and Power Analyze Software

General Specifications

Power Quality Measurement Standards

Conformance IEC 61999-1-4 Class 1, IEC 61000-4-30 Class A or B depending on measurement function, IEEE519, IEEE1159, IEEE1459

Clock/Calendar Leap years, 24-hour clock

Real-time Clock Accuracy Not more than ± 1 s/day

Internal Memory Capacity for Data At least 1 GB

Maximum Recording Period At least 31 days

Measurement Time Control Automatic

Maximum Number of Events Limited only by the size of the internal memory.

Power Requirements 100 to 240 V rms ± 10 %, 47-63 Hz, 40 W

Operating Time During Interruptions

(internal UPS operation) 5 minutes per interruption, 60 minutes total operating time without recharging

Dimensions 215 x 310 x 35 mm (8.5 x 12.2 x 3.5 inch)

Mass (Weight) 6.3 kg (14 lbs)

Input Specifications

Measurement Types One Phase Plus Neutral, One Phase IT No Neutral, One Phase Split Phase, Three Phase Wye, Three Phase Delta, Three Phase IT, Three Phase High Leg, Three Phase Open Leg, 2 Element Delta, 2 1/2 Element Wye

Input Channels Voltage: 5 channels, AC/DC
Current: 5 channels

Voltage Channels Input resistance: 2 M Ω
Input capacitance: <20 pF

Current Channels 1 M Ω . Self-identifying probes
Types available: current clamps, Flexi-CTs

Measuring Method Simultaneous digital sampling of voltage and current. Digital PLL synchronized sampling, internal frequency reference used during voltage drops.

Synchronization and Sampling

PLL-Synchronization Source.....	The PLL synchronizes to the A-N voltage for wye power types, and to the A-B voltage for delta power types. All listed power types can be characterized as either wye or delta.
PLL Lock Range.....	42.5 to 69 Hz
Sampling Frequency	Voltage and current: 256 samples/cycle Inter-harmonics per IEC61000-4-7: 2560 samples / 10 cycles (50 Hz), 3072 samples/12 cycles (60 Hz) Transient Voltage: 5 MHz
A/D Resolution	Voltage and current: 24 bits Transient voltage: 14 bits

Voltage and Current Measurements

Voltage Measurement Range.....	AC voltage: 1000 V rms \pm 10 % Overrange DC voltage: \pm 1000 V + 10 % Overrange
Voltage Crest Factor.....	3 or less
Voltage Input Impedance	2 M Ω
Current Measurement Range.....	Depends on current probe used
Current Crest Factor.....	4 or less
Current Input Characteristics	2 V rms = full scale, 1 M Ω Input Impedance for ferro CTs, low impedance for Flexi-CTs

Voltage and Current Measurement Accuracy

RMS Voltage

Measurement Type.....	True rms calculated continuously: every cycle, every 1/2 cycle, and every 10 or 12 cycles at 50 or 60 Hz respectively, as required by IEC 61000-4-30.
Measurement Uncertainty.....	AC: \pm 0.2 % reading \pm 0.1 % full scale above 50 V rms DC: \pm 0.5 % reading \pm 0.2 % full scale above 50 V dc If the ac component of a dc signal is below 40 V rms, the dc uncertainty specification may have an offset.

RMS Current

Measurement Type.....	True rms calculated continuously: every cycle, every 1/2 cycle, and every 10 or 12 cycles at 50 or 60 Hz respectively, as required by standards
Measurement Uncertainty.....	\pm (0.1 % full scale + 0.5 % reading + current sensor accuracy, valid for 5 % to 100 % of current sensor range
Current Accuracy	Ferromagnetic Clamps \pm (0.1 % full scale + 0.2 % reading + current sensor accuracy), valid for 5 % to 100 % of current sensor range Flexible Current Probes \pm (0.1 % full scale + 0.5 % reading + current sensor accuracy), valid for 5 % to 100 % of current sensor range

Transient Voltage (Impulse)

Measurement Type.....	Waveshape sampling, not peak detect
Full Scale	8000 V pk
Sample Resolution.....	200 nS
Measurement Uncertainty.....	\pm 5 % reading \pm 20 V (test parameters: 1000 V dc, 1000 V rms, 100 kHz)

Dip (Sag) and Swell Measurements

Voltage Swell (rms swell)

Measurement Type.....	True rms (one cycle calculation by overlapping each half cycle) (voltage between lines is measured for 3P3W lines and phase voltage is measured for 3P4W lines)
Displayed Data	Amplitude and duration of swell

Measurement Accuracy	Same as rms voltage
Voltage Dip (RMS sag)	
Measurement Type	True rms (one cycle calculation by overlapping each half cycle) (voltage between lines is measured for 3P3W lines and phase voltage is measured for 3P4W lines)
Displayed Data	Amplitude and duration of dip or interruption
Measurement Accuracy	Same as rms voltage
Voltage Dropout (Interruption)	
Measurement Type	Same as Voltage Dip

Power and PF Measurement

Power

Measurement Method	Calculated per IEEE1459 for best performance when distortions exist
Measurement Type	True rms calculated continuously: every cycle, and every 10 or 12 cycles at 50 or 60 Hz respectively, as required by standards
Measurement Accuracy	± 0.2 % reading ± 0.1 % full scale + current sensor accuracy

Frequency

Measurement Range	42.5 to 69 Hz
Measurement Source	Same as PLL synchronization source
Measurement Accuracy	± 10 mHz (10 to 110 % of range, with sine wave)

Reactive Power

Accuracy	± 0.2 % reading ± 0.1 % full scale + current sensor accuracy
----------------	--

Power Factor

Measurement Range	-1.000 (leading) to 0.000 to +1.000 (lagging)
Measurement Accuracy	± 1 digit from the calculation of each measured value (± 3 digits for total)

Displacement Power Factor

Measurement Method	Calculated from the phase difference between voltage fundamental and current fundamental
Measurement Range	- 1.000 (leading) to 0.000 to + 1.000 (lagging)
Measurement Accuracy	± 0.5 % reading ± 2 % full scale ± 1 digit

Voltage Unbalance and Phase Sequence

Measurement Method	Positive sequence voltage divided by negative sequence voltage, per IEC 61000-4-30
--------------------------	---

Harmonic Voltage and Current

Analysis Window	rectangular
Analysis Order	1st to 50th order
Measurement Accuracy	Voltage / Current: 1st to 20th orders: ± 0.5 % reading ± 0.2 % full scale 21st to 50th orders: ± 1 % reading ± 0.3 % full scale (current sensor accuracy must be included for current and power)
Measurement Method	IEC 61000-4-7

Inter-harmonic Voltage and Current (Intermediate Harmonics)

Analysis Window	rectangular
Analysis Orders	0.5 to 49.5th order
Measurement Method	IEC 61000-4-7

External Interface Specifications

LAN Interface

Connector	RJ-45
Speed and Type	10/100 Base-T, auto MDIX
Communications Protocol	TCP/IP over Ethernet
Wireless Controller Interface	
Connection	wireless (2.4 GHz radio)
Speed	up to 700 kbit/second
Communications Protocol	Bluetooth SPP

Environmental and Safety Specifications

Operating Environment	indoors or in covered area outdoors, up to 2000 m altitude
Storage Temperature and Humidity.....	-20 °C to 50 °C, 80 % rh max, non-condensing
Operating Temperature and Humidity	0 °C to 40 °C, 80 % rh max, non-condensing
Maximum Rated Working Voltage	
Voltage Terminals	1100 V rms
Voltage Durability.....	5550 V rms ac for 1 minute, between voltage input terminals, voltage input terminals and current probes, and voltage input terminals and case (50/60 Hz, 1 mA sense current)
Enclosure Protection.....	IP30 (per EN 60529)
Standards Conformance	
EMC	EN 61326-1:2000 Class A EN 61000-3-2:1995+A1:1998+A2:1998 EN 61000-3-3:1995
Safety.....	EN 61010-1:2 nd Edition Voltage input unit: Contamination Level 2 Measurement Category 1000 V CAT III, 600 V CAT IV (transient: 8 kV)

Cleaning and Maintenance

Caution

To avoid damage to the Recorder, do not apply abrasives or solvents to the housing.

The Recorder contains no user serviceable parts. Contact an authorized Fluke service center for repair. See Contacting Fluke.

Periodically wipe the case with a damp cloth and mild detergent.

Required Equipment

For a list of required equipment for the verification tests and calibration adjustment, see Tables 2 and 3.

Table 2. Required Equipment

Equipment	Required Characteristics	Recommended Model
Calibrator	AC Voltage Range: 0 - 1000 V ac Accuracy: ± 0.03 % Frequency Range: 50 - 10000 Hz DC Voltage Range: 0 - 1000 V dc Accuracy: ± 0.03 %	Fluke 5520A Multi-Product Calibrator or equivalent
Multimeter with 4-wire Ohms	Ohms Range: 100 K Ω Accuracy: ± 0.011 %	Fluke 8846A Precision Multimeter or equivalent
Personal Computer (PC) (Windows XP)	1750 Cal Wizard and Fluke Power Analyze software installed	

The cables listed in Table 3 are necessary for verification and calibration adjustment. To assemble the cables, see cable assembly figures in the Test Cables section.

Table 3. Required Cables

Cable	Required Characteristics	Notes
Ethernet cable	CAT 5 with RJ-45 connectors	Supplied with the Recorder
Voltage calibration cable with BNC-banana adapter	Double banana to safety banana and spade lug	See Figure 5
Four jumper cables, safety-banana type		
Current calibration cable	Shielded cable with double banana to CT pins in Redel connector with 100 A CT ID resistor	See Figure 6
Rogowski resistor measurement cable	Safety banana to Redel	See Figure 4
Rogowski calibration cable	Shielded cable with double banana to Rogowski pins in Redel connector with 100 A Rogowski ID resistor	See Figure 3
Ground calibration cable	Lug to banana	See Figure 2
Fluke recommends the use of Pomona brand cables and banana plugs when building these cables.		

Verification Tests

⚠⚠ Warning

To avoid electrical shock, personal injury, or fire:

- Do not perform the calibration procedures or calibration verification tests described in this manual unless you are qualified to do so.
- Repairs or servicing should be performed only by qualified personnel.

The following tests are used to verify the functions of the Recorder. If the Recorder fails any of the verification tests, calibration or repair may be needed. For service, see Contacting Fluke.

Note

Power Analyze can be set to display the channels as L1, L2, and L3 instead of A, B, and C. The channels on the Recorder could also be labeled A, B, and C, or L1, L2, and L3, depending on which decal was applied to the Recorder front panel. For this manual A, B, and C are used.

AC Voltage Accuracy Verification

1. Connect an Ethernet cable to the Recorder.
2. Apply power to the Recorder. During power up, indicators near all jacks should flash.
3. Launch Power Analyze software on a personal computer (PC).
4. Select the Recorder to be tested in the drop down box next to the **Scope** button.
5. Select **1750 Live**, then **Scope**.
6. Check all the voltage display check boxes to the right of the scope display. Make sure the correct items are checked.

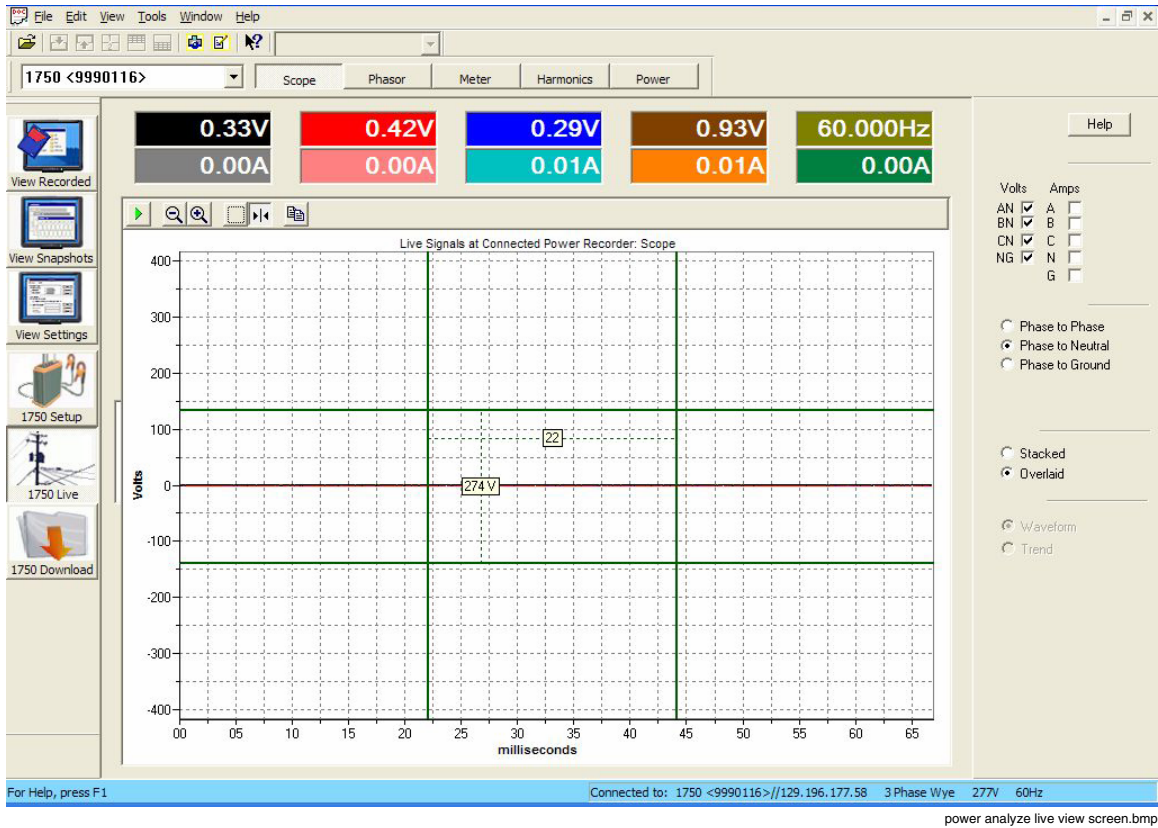

Figure 1. Power View Software Live View

7. Connect the calibrator **NORMAL HI** to inputs **A, B, C**, and \perp of the Recorder.
8. Connect the **NORMAL LO** to input **N** and the protective conductor terminal \oplus of the Recorder.
9. Apply the voltages from Table 4 and list the Recorder readings for channels **AN, BN, CN**, and **NG** in the appropriate areas. Sine waves will be displayed for **AN, BN** and **CN**, all at the same amplitude and phase shift. **NG** will be inverted.

Note

*If the voltage goes over scale, right click on the voltage scale on the left margin of the graphical display, then click on the **Zoom to Fit** box to resize.*

Table 4. AC Voltage Accuracy Verification

Applied	AN Reading	BN Reading	CN Reading	NG Reading	Limits
60 Vrms @ Local Hz					± 1.12 V
240 Vrms @ Local Hz					± 1.48 V
600 Vrms @ Local Hz					± 2.20 V

10. Verify that **A, B, C**, and \perp LEDs are on. **N** should be off.
11. Set the calibrator to **STBY**.
12. Verify that **A, B, C**, and \perp LEDs are off.

Neutral Voltage Verification

1. Connect **NORMAL LO** to **A, B, C, \perp** , and \oplus .
2. Connect the calibrator **NORMAL HI** to **N** on the Recorder.
3. Apply the voltages from Table 5, listing the Recorder readings for the appropriate model.

Table 5. Neutral (AC) Voltage Accuracy Check

Applied	NG Reading	Limits
60 V @ Local Hz		± 1.12 V
100 V @ Local Hz		± 1.20 V

4. Verify that the **N** LED is on.
5. Set the calibrator to **STBY**, verify that the LED for **N** turns off.
6. Disconnect the test leads from the Recorder.

Rogowski Current Verification

1. Verify the resistor in the Rogowski calibration cable is within 0.1 % of 100 k Ω .
2. Connect the calibrator **NORMAL HI** to **Voltage A, B, and C** on the Recorder.
3. Connect the calibrator **NORMAL LO** to **N** and **Voltage \perp** on the Recorder.
4. Connect the calibrator **AUX HI** and **LO** to current input **A** using the Rogowski calibration cable. See Figure 3.
5. Set the calibrator output to 120.0 V @ 55 Hz on the **NORMAL** output and the values from Table 6 the **AUX** output.
6. Press the **WAVE MENU** softkey and ensure the phase angle is -90 °.
7. Press the **HARMONIC MENU** softkey; ensure the **HARMONIC** selection is set to 1 and the **FUNDMTL** selection is set to **aux**.
8. Press **OPR**.
9. Set the calibrator to voltages from Table 6 and list the Recorder readings for channel **A**.
10. Move cable to next channel and repeat step 9 for channels **B, C, N,** and \perp .

Table 6. Rogowski Current Accuracy Check

Applied Voltage	Expected Current	Expected Reading	A Reading	B Reading	C Reading	N Reading	G Reading	Limits
0.649 V	6.49 μ A	20 A						± 0.20 A
1.6225 V	6.225 μ A	50 A						± 0.35 A
3.245 V	32.45 μ A	100 A						± 0.60 A

CT Current Verification

1. Connect the calibrator **NORMAL HI** to Voltage **A**, **B**, and **C** on the Recorder.
2. Connect the calibrator **NORMAL LO** to Voltage **N** and \perp on the Recorder.
3. Connect the calibrator **AUX HI** and **LO** to current input **A** using the current test cable. See Figure 6. The current test calibration cable connects the voltage to all current sense inputs and indicates that a 100 A current transformer is attached.
4. Set the calibrator output to 120.0 V @ 50 or 60 Hz on the **NORMAL** output and the values from Table 7 on the **AUX** output.
5. Press the **WAVE MENUS** softkey and ensure the phase angle is 0.0 $^{\circ}$.
6. Press the **HARMONIC MENU** softkey; ensure the **HARMONIC** selection is set to 1 and the **FUNDMTL** selection is set to **aux**.
7. Press **OPR**.
8. Set the calibrator to voltages from Table 7 and list the Recorder readings for that channel.

Table 7. CT Current Accuracy Check

Applied Voltage	Expected Reading	A Reading	B Reading	C Reading	N Reading	G Reading	Limits
0.4 V	20 A						± 0.20 A
1.0 V	50 A						± 0.35 A
2.0 V	100 A						± 0.60 A

9. Verify that the current LED is on.
10. Move cable to next channel and repeat steps 8 and 9 for channels **B**, **C**, **N**, and \perp .
11. Set the calibrator to **STBY**. Verify that the current LEDs turn off.

Watt Verification

1. Use the same connections as the CT current verification and apply 440 V and local line frequency out of the **NORMAL** output and 1.9 V on the **AUX** output.
2. Click on the power button in Power Analyze. The **A**, **B** and **C** should be 41.8 kW \pm 0.3 kW.
3. On the calibrator press the blue button for **Phase** and **Ref Menu**.
4. Press the blue button for **AUX Phase NRM**.
5. Enter 90 with the numerical keypad and press **Enter**. The power should be 0 \pm 0.1 kW.

Impulse Verification

Initialize the UUT

⚠⚠ Warning

The impulse verification steps instruct the user to apply working voltages in excess of 700 V, so extreme caution must be applied. To avoid electrical shock or personal injury, DO NOT use connectors having exposed metal.

1. Power down the UUT until Power LED turns off, approximately five minutes.
2. Power up the UUT and wait for start up, and connect with Power Analyze.
3. Select **Tools>Erase 1750 Memory** to empty the UUT data.

Normalize Thresholds

4. Connect the calibrator **NORMAL LO** to the UUT \ominus terminal.
5. Connect the voltage test cable to the calibrator **NORMAL HI** jack, leaving the safety-connector end free.
6. Set the calibrator to 750 V 10 kHz.
7. Press **OPR** on the calibrator.
8. Connect the voltage test cable to UUT voltage input \perp for approximately 15 seconds, and then disconnect.

Apply Stepped Verification Voltages to Voltage Inputs A, B, C, N, and \perp

9. Set the calibrator to 800 V 10 kHz.
10. Connect the voltage test cable to UUT voltage input **A** for approximately 15 seconds, and then disconnect.
11. Set the calibrator to 850 V 10 kHz.
12. Connect the voltage test cable to UUT voltage input **B** for approximately 15 seconds, and then disconnect.
13. Set the calibrator to 900 V 10 kHz.
14. Connect the voltage test cable to UUT voltage input **C** for approximately 15 seconds, and then disconnect.
15. Set the calibrator to 950 V 10 kHz.
16. Connect the voltage test cable to UUT voltage input **N** for approximately 15 seconds, then disconnect.

17. Set the calibrator to 1000 V 10 kHz.
18. Connect the voltage test cable to UUT voltage input \perp for approximately 15 seconds, then disconnect. Note, this signal is designated **G** in Power Analyze.
19. Press **STBY** on the calibrator.
20. Set the calibrator to 0 V 0 Hz.

To Use Power Analyze to Verify the Amplitude Accuracy of Recorded Impulse Events

21. Wait two minutes for the UUT to compile event information.
22. Click on **1750 Download**, and then **Save**.
23. Click on **View Recorded**, and then **Events**.
24. On the right side, verify that all four **Volts** selections are checked and all five **Amps** selections are unchecked in **Phase Selection**, and **Phase to Neutral** is selected in **Voltage Reference**.
25. Click on **Event Detector**.
26. Select **all channels the same** and set both **AN** and the **NG** thresholds to 50 %.
27. Click **Done**.
28. Click on **View > Table View > Top Table View**. This changes the Event Summary data at the top of the screen from graph-view to table-view.
29. Click on **View > Screen View > Top Full Screen**. This provides a full screen view of the Event Summary table.
30. The following steps concern the two right-hand columns in the Event Summary table, the Absolute and Triggered Phase columns.
31. Starting from Event 1, scroll down the table through the NG Triggered Phase data until the AN Triggered Phase data is reached. This group of NG Triggered Phase data is from the Normalize Thresholds section of this check. It is not used for verification.
32. Scroll down through the AN Triggered Phase data until the BN Triggered Phase data is reached. Record the sixth-to-last AN Triggered Phase Absolute value in Table 8.
33. Scroll down through the BN Triggered Phase data until CN is reached.
34. Record the sixth-to-last BN Triggered Phase Absolute value in Table 8.
35. Scroll down through the CN Triggered Phase data until N-triggered data is reached. Because voltage events on N cause triggers on **AN**, **BN**, **CN**, and **NG**, (resulting in any one of these labels) this can be most easily distinguished by the change in the Absolute values from the CN Triggered Phase data. Record the sixth-to-last CN Triggered Phase Absolute value in Table 8.
36. Scroll down through the N-triggered data until G-triggered data is reached. As with the previous step this can be most easily distinguished by the change in the Absolute values from the Triggered Phase data.
37. Record the sixth-to-last N-triggered Phase Absolute value in Table 8.
38. Scroll to the bottom of the Event Table until the end of the G-triggered data is reached. These will all show up as NG for Triggered Phase.
39. Record the sixth-to-last N-triggered Phase Absolute value in Table 8.

Table 8. Impulse Verification Inputs

Applied Voltage [Vrms]	Expected Reading [Vpk]	Channel	Measured Magnitude [Vpk]	Limits [Vpk]
800	1131	AN (A)		± 77
850	1202	BN (B)		± 80
900	1273	CN (C)		± 84
950	1344	NG (N)		± 87
1000	1414	NG (G)		± 91

Calibration

Required Equipment

The required equipment and cables for calibrating the Recorder are listed in Tables 2 and 3.

Warning

To avoid electrical shock, personal injury, or fire:

- Do not perform the calibration procedures or calibration verification tests described in this manual unless you are qualified to do so.
- Repairs or servicing should be performed only by qualified personnel.

Calibration Adjustment

The Recorder features closed-case calibration adjustment using known reference sources. During calibration, the Recorder measures the applied reference source, calculates correction factors, and stores the correction factors in nonvolatile memory.

Perform calibration adjustment if the Recorder fails any performance test in the verification procedure.

Note

Calibration should be performed under ambient temperature conditions between 20 °C and 30 °C.

Calibration consists of four parts: I-Wave, I-Rogowski, V-Wave, and V-Impulse. Each part calibrates one measurement system in the Recorder. For each part, the calibration values are checked to be sure the Recorder is working correctly and calibration results are valid. All of the calibration steps for each of the four measurement systems must be completed before the calibration values can be written to the Recorder's nonvolatile memory.

I-Wave, I-Rogowski, and V-Wave channels are calibrated using 55 Hz sine wave signals to minimize 50 Hz or 60 Hz power line interference with the calibration measurements.

V-Impulse channels are calibrated using dc voltages, averaging calibration measurements to suppress power line interference.

Calibration is controlled by 1750 Cal Wizard Software (Cal Wizard), which communicates with the Recorder over Ethernet. Cal Wizard steps through the calibration procedure, with instructions for making cable connections, setting the correct sources, and finalizing the calibration.

The following steps detail the calibration adjustment procedure:

1. Connect the Recorder and the PC to the network with an Ethernet cable. This can either be by direct connection or via a hub on an Ethernet network.
2. Connect ac power to the Recorder. Make sure the Recorder, calibrator, and PC running Cal Wizard software are all properly connected to safety ground.
3. Allow the calibrator and Recorder to warm up (30 minutes for the Recorder). If necessary, run Ohms-Cal or Zero-Cal on the calibrator.
4. Reset the calibrator. Confirm the following calibrator state: 0 V, Standby (OPR LED off), EARTH Off (LED off), and EXGRD Off (LED off).
5. Start Cal Wizard.
6. With Cal Wizard, select the Recorder to be calibrated, and then click **Connect**.

Note

If the Recorder is password protected, the correct password must be supplied to continue.

7. Click **Next**.
8. Follow the on-screen instructions to perform each of the four calibration types. If any of these procedures report a failure, the Recorder must be returned for inspection and service. See Contacting Fluke.
9. If all calibrations are successful, click **Apply** to store the correction values in the Recorder memory. This will take up to a minute to complete.
10. Click **Finish**. The Recorder will shut down and restart using the new calibration values. This may take several minutes.

This concludes Recorder calibration.

Test Cables

The following figures detail the assembly of cables used for calibrating the Recorder.

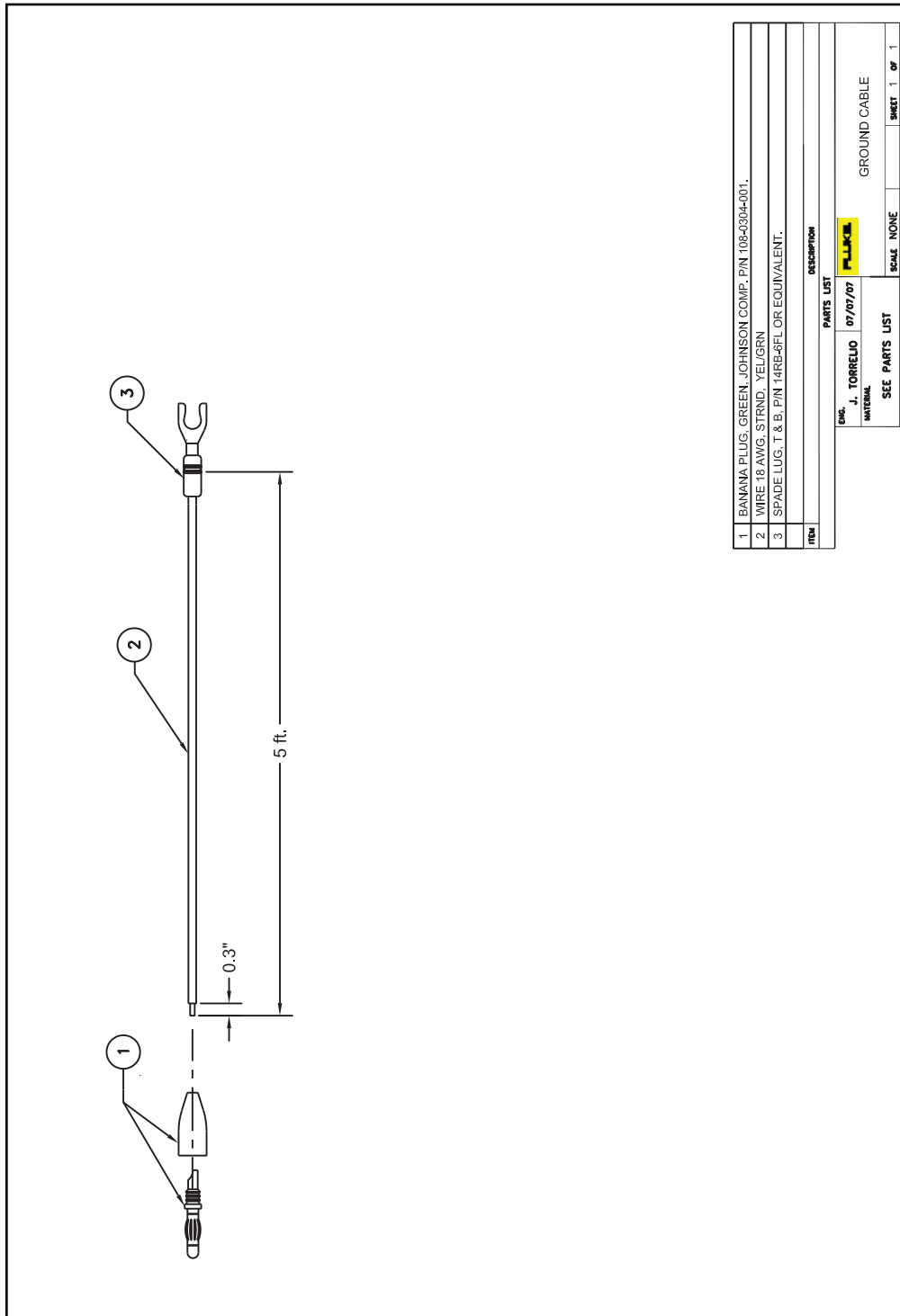

Figure 2. Ground Calibration Cable

fdo02.eps

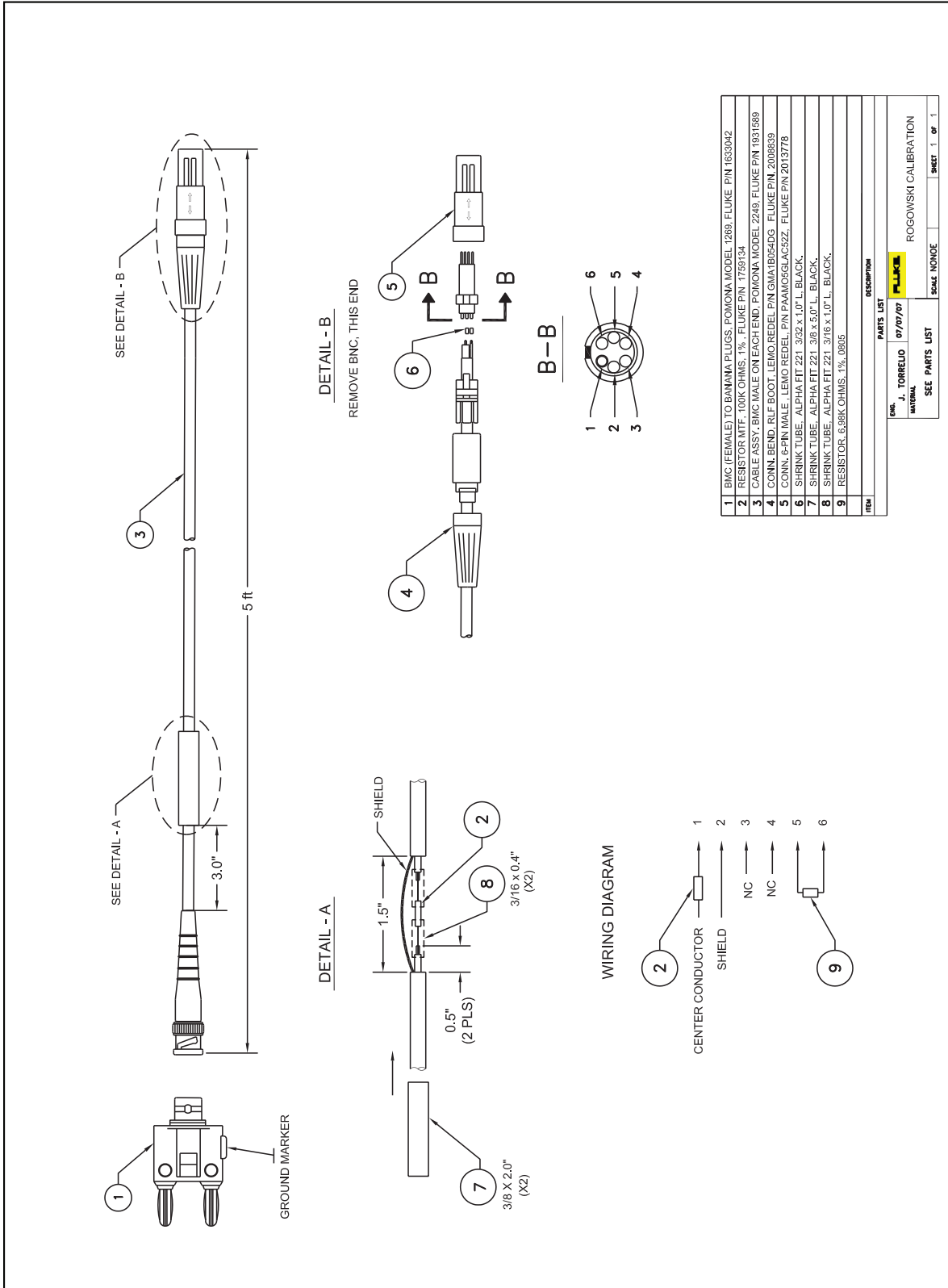

Figure 3. Rogowski Calibration Cable

fdo01.eps

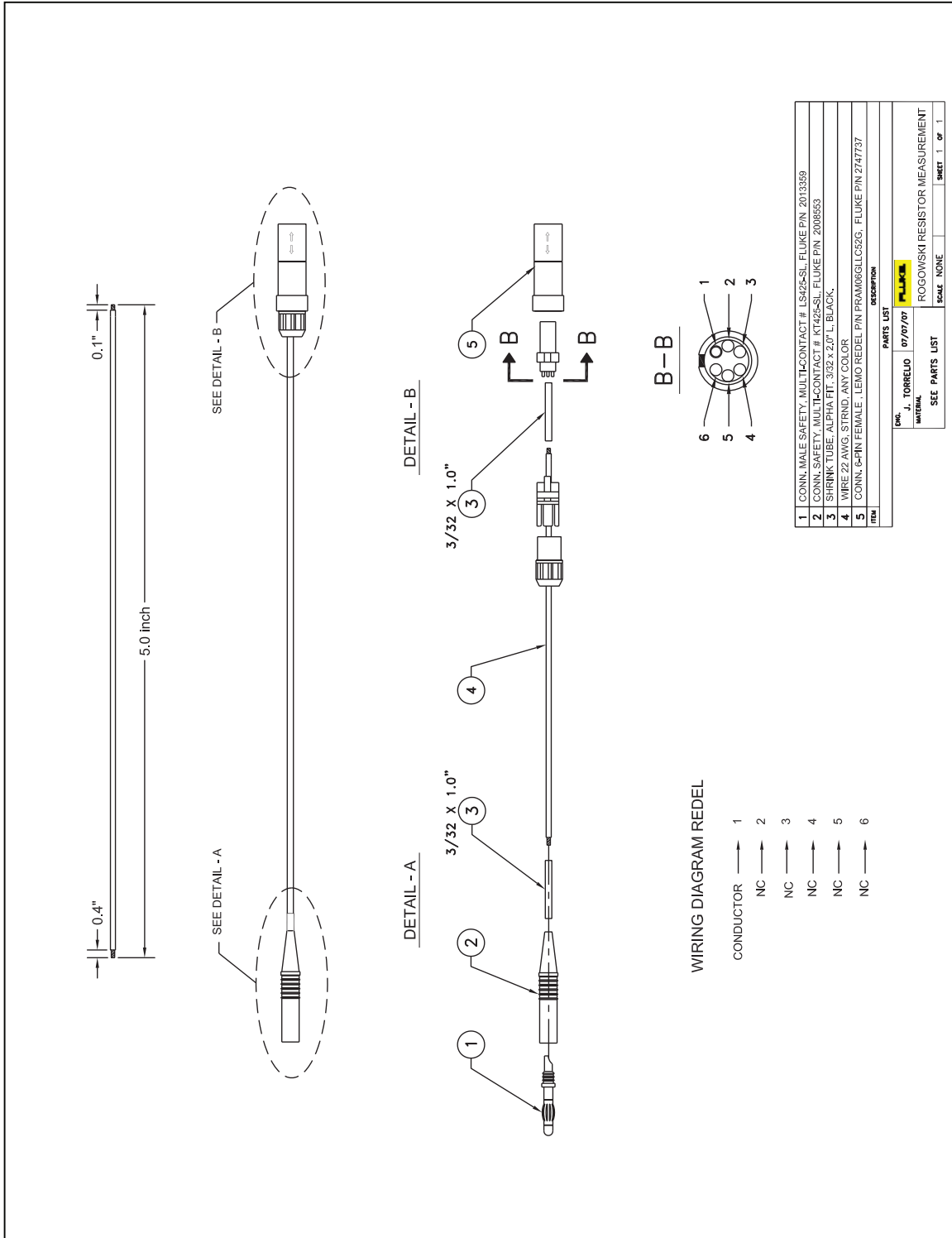

Figure 4. Rogowski Resistor Measurement Cable

fdo05.eps

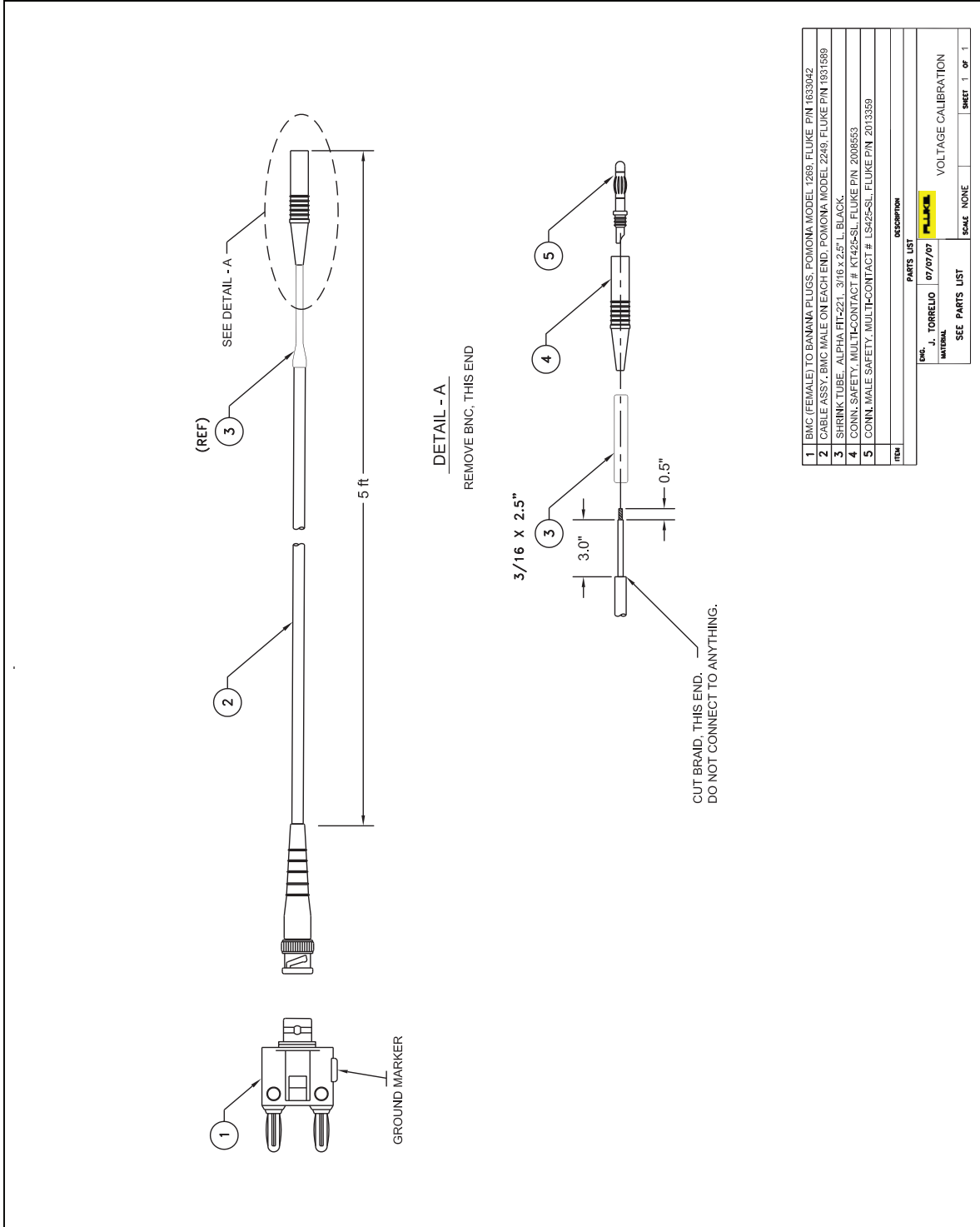

Figure 5. Voltage Calibration Cable

fdo03.eps

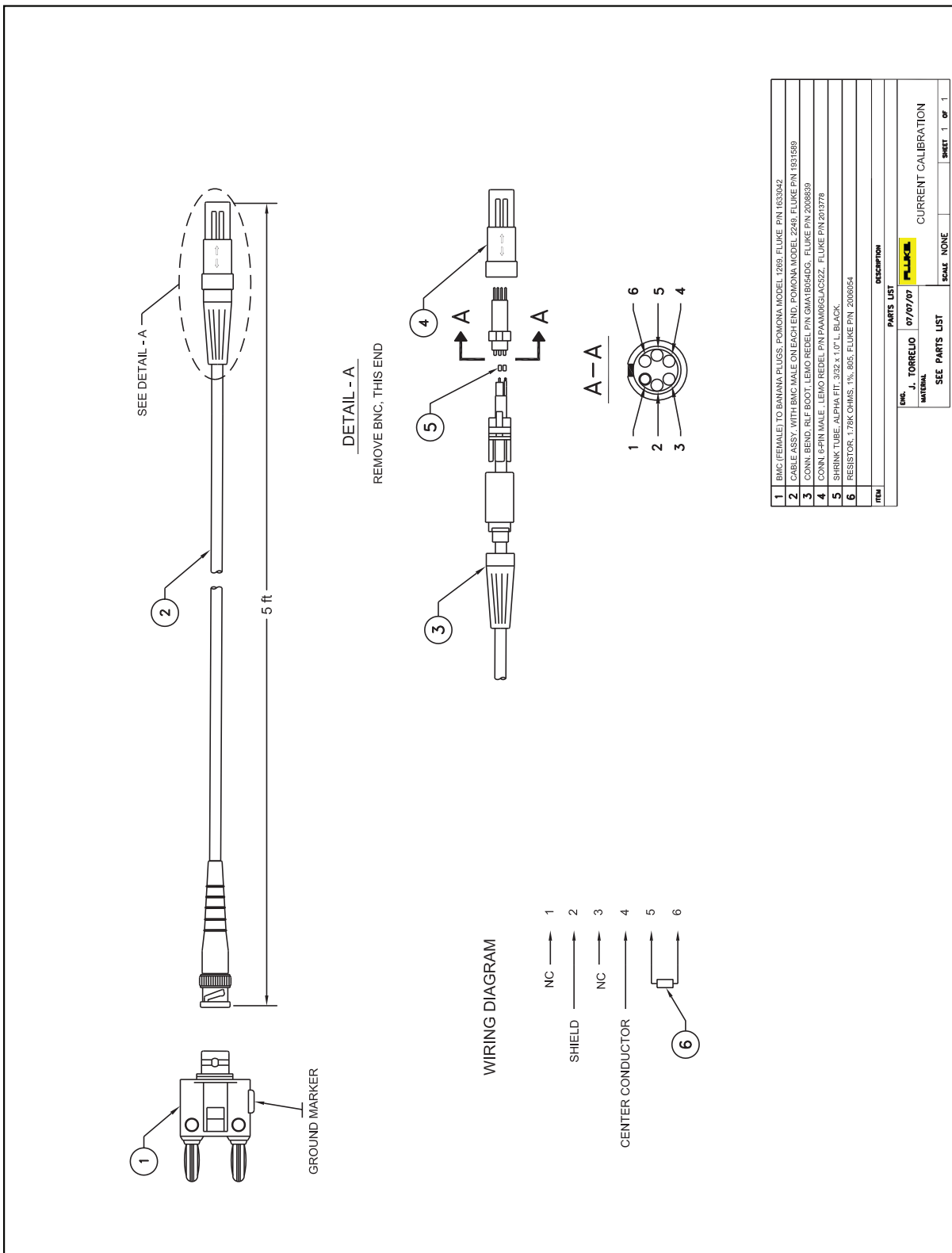

Figure 6. Current Calibration Cable

fdo04.eps