

FLUKE®

i410/i1010

AC/DC Current Clamp

Instruction Sheet

 **Read First: Safety Information**

- Avoid working alone to ensure that assistance can be rendered.
- Do not use the clamp if the clamp or leads appear damaged, or if you suspect that the clamp is not operating properly.
- Use extreme caution when working around bare conductors or bus bars. Accidental contact with the conductor could result in electric shock.
- Use caution when working with voltages above 30V rms or 60V dc. Such voltages pose a shock hazard.
- Never use the clamp on a circuit with a voltage higher than 600V (CAT. III) or a frequency higher than 400 Hz (i410) or 2 kHz (i1010.) The clamp may be damaged if these limits are exceeded.
- Use the clamp only as specified in this instruction sheet; otherwise, the protection provided by the clamp may be impaired.
- Read the operating instructions before use and follow all safety information.
- CAT. III - Industrial Locations (IEC 1010-1).

Features and Connections

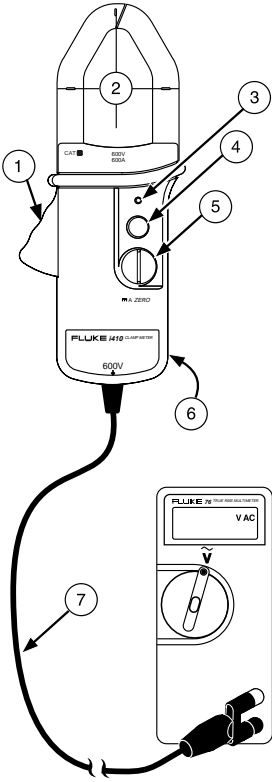

- ① Jaw Lever
- ② Jaw Centering Marks
- ③ ON Indicator
- ④ ON/OFF Switch
- ⑤ Zero Adjust
- ⑥ Battery Access
- ⑦ Output Cable

Minimum voltmeter requirements:

- Accepts safety-shrouded banana plugs.
- Can display 1 mV (0.1 mV preferred)
- Accuracy $\geq 0.75\%$
- Input impedance $\geq 1 \text{ M}\Omega$, $\leq 100 \text{ pF}$.

Measuring DC Current

Maximum: 400A dc (i410) or 1000A dc (i1010)

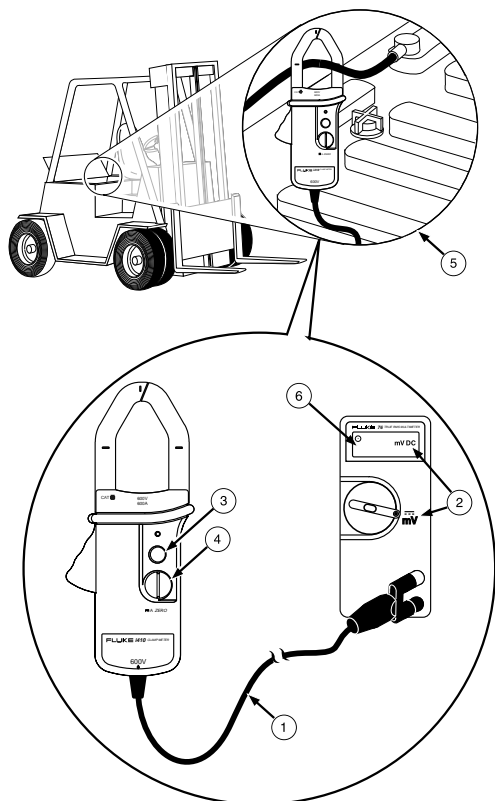

ar002i.eps

- ① Connect to voltmeter.
- ② Select mV dc.
- ③ Set ON.
- ④ Adjust ZERO (jaws empty.)

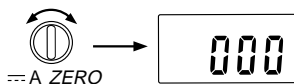

ar006i.eps

- ⑤ Clamp and center around conductor.
- ⑥ Read voltmeter (1 mV = 1A.)

Measuring AC Current

Maximum: 400A ac rms (i410) or 600A ac rms (i1010)

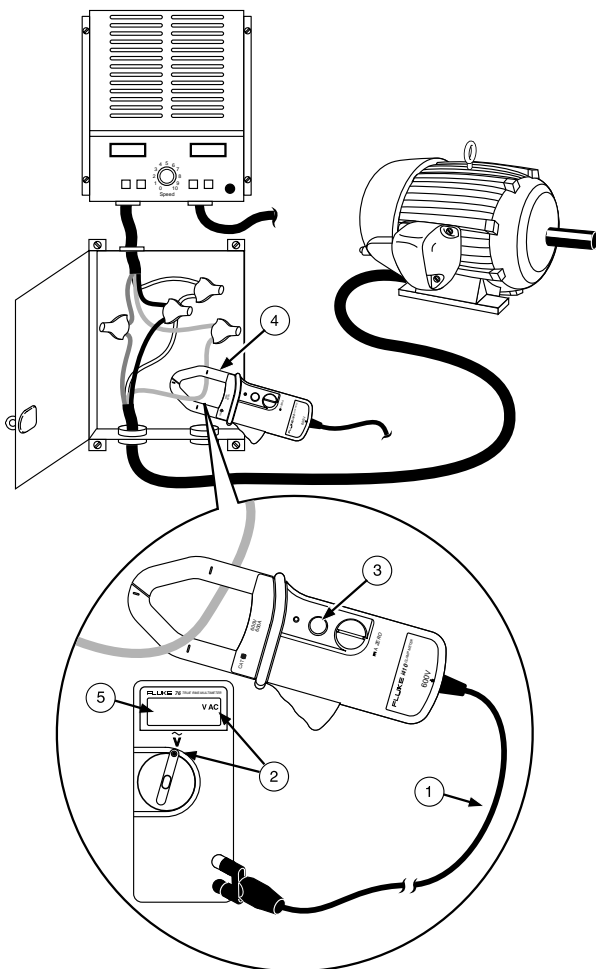

ar003i.eps

- ① Connect to voltmeter.
- ② Select mV ac (or V ac, but resolution may be limited to 1A.)
- ③ Set ON.
- ④ Clamp and center around conductor.
- ⑤ Read voltmeter (1 mV = 1A.)

Testing the Battery

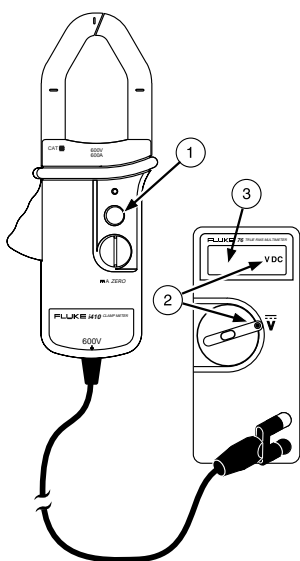

ar004i.eps

- ① Set OFF.
- ② Select V dc.
- ③ $\leq 7.0V$ dc = replace battery.

(Voltmeter input impedance $\geq 1 M\Omega$)

Replacing the Battery

For specified battery life, use an alkaline battery.

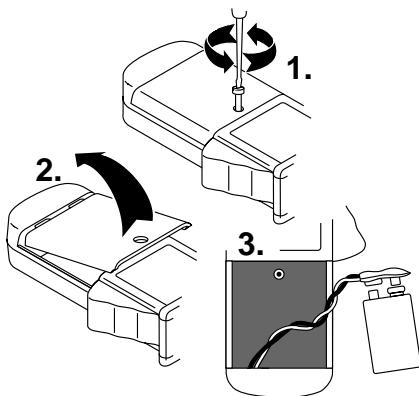

ar005i.eps

If the Current Clamp Does Not Work

Check	Correct
Battery = OK?	Refer to "Testing the Battery."
Voltmeter connections?	Red to + or $V\Omega$ \rightarrow Black to COM
Voltmeter function/range?	mV dc mV ac (or V ac)

Storage

During longer periods of non-use (> 60 days), remove and store the battery separately.

Cleaning

Periodically wipe the case with a damp cloth and mild detergent. Do not use abrasives or solvents.

Service and Parts

The Current Clamp should be serviced only by a qualified service technician. For service information, contact your nearest Fluke dealer or service center.

Specifications

Operating Temperature	-10 to 50°C (14 to 122°F)
Storage Temperature	-20 to 60°C (-4 to 140°F)
Relative Humidity	0 to 95% (0 to 30°C) 0 to 75% (30 to 40°C) 0 to 45% (40 to 50°C)
Altitude Operating Non-operating	0 - 2000m 0 - 12000m
Battery Type	9V (alkaline)
Battery Life	60 hrs typical (continuous with alkaline)
Safety	 Double Insulation, 600V rms, CAT. III
Current x Hz Product	$\leq 240,000$
Output Signal	1 mV per amp dc or ac
Working Voltage	600V rms, CAT. III maximum at input
Maximum Conductor Size	1 ea. 30 mm (1.18 in.) diameter 2 ea. 25 mm (0.98 in.) diameter
Load Impedance	$\geq 1 \text{ M}\Omega$, $\leq 100 \text{ pF}$
Temperature Coefficient	+/- (0.05 x accuracy per °C (0 -18°C, 28-50°C)
Size	209 x 78 x 48 mm (3.09 x 8.21 x 1.87 in.)
Weight	0.5 kg (17.6 oz.)

	i410	i1010
Specified Current Range:	1 - 400A ac rms * 1 - 400A dc	1 - 600A ac rms * 1 - 1000A dc
Usable Current Range:	0.5 - 400A	0.5 - 1000A
DC Accuracy (zero adjusted, conductor centered)	3.5% + 0.5A (0 - 400A)	2.0% + 0.5A (0-1000A)
AC Accuracy	3.5% + 0.5A, 45 - 400 Hz, Crest Factor \leq 3. (0 - 400A)	2.0% + 0.5A, 45 - 400 Hz, Crest Factor \leq 3. 3.0% + 0.5A, 400 Hz - 2 kHz sine wave. (0 - 600A)
Bandwidth	3 kHz	10 kHz
* With a true-rms voltmeter, the minimum ac current is limited to the low end of the specified mV ac range.		

LIMITED WARRANTY & LIMITATION OF LIABILITY

Each Fluke product is warranted to be free from defects in material and workmanship under normal use and service. The warranty period is one year and begins on the date of shipment. Parts, product repairs and services are warranted for 90 days. This warranty extends only to the original buyer or end-user customer of a Fluke authorized reseller, and does not apply to fuses, disposable batteries or to any product which, in Fluke's opinion, has been misused, altered, neglected or damaged by accident or abnormal conditions of operation or handling. Fluke warrants that software will operate substantially in accordance with its functional specifications for 90 days and that it has been properly recorded on non-defective media. Fluke does not warrant that software will be error free or operate without interruption.

Fluke authorized resellers shall extend this warranty on new and unused products to end-user customers only but have no authority to extend a greater or different warranty on behalf of Fluke. Warranty support is available if product is purchased through a Fluke authorized sales outlet or Buyer has paid the applicable international price. Fluke reserves the right to invoice Buyer for importation costs of repair/replacement parts when product purchased in one country is submitted for repair in another country.

Fluke's warranty obligation is limited, at Fluke's option, to refund of the purchase price, free of charge repair, or replacement of a defective product which is returned to a Fluke authorized service center within the warranty period.

To obtain warranty service, contact your nearest Fluke authorized service center or send the product, with a description of the difficulty, postage and insurance prepaid (FOB Destination), to the nearest Fluke authorized service center. Fluke assumes no risk for damage in transit. Following warranty repair, the product will be returned to Buyer, transportation prepaid (FOB Destination). If Fluke determines that the failure was caused by misuse, alteration, accident or abnormal condition of operation or handling, Fluke will provide an estimate of repair costs and obtain authorization before commencing the work. Following repair, the product will be returned to the Buyer transportation prepaid and the Buyer will be billed for the repair and return transportation charges (FOB Shipping Point).

THIS WARRANTY IS BUYER'S SOLE AND EXCLUSIVE REMEDY AND IS IN LIEU OF ALL OTHER WARRANTIES, EXPRESS OR IMPLIED, INCLUDING BUT NOT LIMITED TO ANY IMPLIED WARRANTY OF MERCHANTABILITY OR FITNESS FOR A PARTICULAR PURPOSE. FLUKE SHALL NOT BE LIABLE FOR ANY SPECIAL, INDIRECT, INCIDENTAL OR CONSEQUENTIAL DAMAGES OR LOSSES, INCLUDING LOSS OF DATA, WHETHER ARISING FROM BREACH OF WARRANTY OR BASED ON CONTRACT, TORT, RELIANCE OR ANY OTHER THEORY.

Since some countries or states do not allow limitation of the term of an implied warranty, or exclusion or limitation of incidental or consequential damages, the limitations and exclusions of this warranty may not apply to every buyer. If any provision of this Warranty is held invalid or unenforceable by a court of competent jurisdiction, such holding will not affect the validity or enforceability of any other provision.

Fluke Corporation	Fluke Europe B.V.
P.O. Box 9090	P.O. Box 1186
Everett WA	5602 B.D. Eindhoven
98206-9090	The Netherlands