



Franklin Electric
GRID SOLUTIONS

CELLTRON™ ADVANTAGE DIGITAL

USER'S GUIDE

The information in this publication is provided for reference only. While every effort has been made to ensure the reliability and accuracy of the information contained in this manual at the time of printing, we recommend that you refer to the appropriate website for the most current version of this manual. All product specifications, as well as the information contained in this publication, are subject to change without notice. Franklin Electric Co., Inc. does not assume responsibility and expressly disclaims liability for loss, damage, or expense arising out of, or in any way connected with, installation, operation, use, or maintenance by using this manual. Franklin Electric Co., Inc. assumes no responsibility for any infringement of patents or other rights of third parties that may result from use of this manual or the products. We make no warranty of any kind with regard to this material, including, but not limited to, the implied warranties of merchantability and fitness for a particular purpose.

Copyright © 2021 Franklin Electric Co., Inc., Madison, WI 53718. All world rights reserved. No part of this publication may be stored in a retrieval system, transmitted, or reproduced in any way, including, but not limited to, photocopy, photograph, magnetic, or other record, without the prior written permission of Franklin Electric Co., Inc.

For technical assistance, please contact:

franklinfueling.com

3760 Marsh Rd. • Madison, WI 53718 • USA

Tel: USA & Canada +1 800 225 9787 • Fax: +1 608 838 6433

Tel: UK +44 (0) 1473 243300 • Tel: Mex 001 800 738 7610

Tel: DE +49 6571 105 380 • Tel: CH +86 10 8565 4566

CELLTRAQ and CELLTRON are trademarks of Franklin Electric Company, Inc.

167-000450 r7

CONVENTIONS USED IN THIS MANUAL

This manual includes safety precautions and other important information presented in the following format:

NOTE: This provides helpful supplementary information.

IMPORTANT: This provides instructions to avoid damaging hardware or a potential hazard to the environment, for example: fuel leakage from equipment that could harm the environment.

▲ CAUTION: This indicates a potentially hazardous situation that could result in minor or moderate injury if not avoided. This may also be used to alert against unsafe practices.

▲ WARNING: This indicates a potentially hazardous situation that could result in severe injury or death if not avoided.

▲ DANGER: This indicates an imminently hazardous situation that will result in death if not avoided.

OPERATING PRECAUTIONS

▲ WARNING: IMPORTANT SAFETY INSTRUCTIONS. BEFORE INSTALLING ANY FRANKLIN ELECTRIC GRID SOLUTIONS EQUIPMENT, READ THIS GUIDE AND FOLLOW SAFETY AND OPERATING INSTRUCTIONS. SAVE THESE INSTRUCTIONS.

▲ WARNING: Risk of explosive gases: Batteries generate explosive gases during normal operation, and when discharged or charged.

▲ WARNING: To reduce risk of battery explosion, follow these safety instructions and those published by the battery manufacturer and the manufacturer of any equipment you intend to use in the vicinity of a battery. Review cautionary marking on these products and on the battery cabinets, battery racks, battery rooms, and on equipment containing the battery.

▲ WARNING: Do not disassemble any equipment; contact Franklin Electric Grid Solutions when a repair is required. Incorrect reassembly may result in a risk of electric shock or fire.

▲ WARNING: Use Franklin Electric Grid Solutions equipment in a dry, well-ventilated area.

▲ WARNING: Do not expose Franklin Electric Grid Solutions equipment to rain or snow.

▲ WARNING: To avoid electric shock when testing jars, abide by your company's safety practices and the following guidelines:

▲ WARNING: Perform service work only for which you have been trained.

▲ WARNING: Refer to NFPA 70E for electrical safety requirements.

▲ WARNING: Use of Personal Protection Equipment (PPE) and Protective Clothing per NFPA 70E guidelines is required. Some examples of these, but not limited to, are: Electrical-insulating, acid-resistant, and protective gloves and sleeves per ASTM D 120, OSHA 29 CFR 1910.137, and NFPA 70E requirements; Protective footwear; Aprons (acid-resistant); Insulating blankets; On-site spill kits; Protective clothing for voltage levels, level of corrosive protection, and the amount of arc-flash protection provided; Insulated rescue hooks or other means for pulling personnel from live circuits; Eyewash stations or portable eyewash bottles; Class "C" dry chemical re extinguishers instead of water around battery systems.

▲ WARNING: Always have someone within range of your voice, or close enough to come to your aid, when working around lead acid batteries.

▲ WARNING: Have plenty of fresh water and baking soda nearby in case battery acid contacts skin, clothing or eyes.

▲ WARNING: If battery acid contacts skin or clothing, wash immediately with baking soda and water. If acid enters the eye, immediately flush with cold running water for at least 10 – 15 minutes, and seek medical attention.

▲ WARNING: Never smoke or allow a spark or ame in the vicinity of a battery or engine.

▲ WARNING: Be extra cautious to reduce risk of dropping a metal tool onto the battery. It might spark or short circuit the battery or other electrical part that may cause an explosion.

▲ WARNING: Before working with a lead-acid battery, remove personal metal items such as rings, bracelets, necklaces, watches, etc. A lead-acid battery can produce a short circuit current high enough to weld such items causing a severe burn.

▲ WARNING: Always wear safety glasses with side shields in the vicinity of battery work per 29CFR1910.133 (OSHA).

▲ WARNING: Do not disconnect the battery cables from power systems during the test without authorization.

▲ WARNING: Do not place yourself in an electrical circuit.

▲ WARNING: Avoid simultaneous contact with the jar and with the battery cabinet, racks, or hardware that may be grounded.

▲ WARNING: Battery posts, terminals, and related accessories contain lead and lead compounds, chemicals known to cause cancer and birth defects or other reproductive harm. Wash hands after handling.

CONTENTS

INTRODUCTION.....	1
SAFETY	1
GENERAL SAFETY PRECAUTIONS.....	1
PERSONAL PRECAUTIONS.....	2
TESTING PRECAUTIONS	2
ABOUT THE TESTER	3
TEST CAPABILITY	3
MEASUREMENTS	3
TEST RANGE	3
DATA STORAGE.....	3
SPECIFICATIONS	4
PRODUCT MAP	5
NAVIGATION HELP/QUICK NAVIGATION.....	7
HOT KEYS.....	8
MAIN MENU OVERVIEW.....	9
SETUP.....	12
FILE TYPE.....	12
TEMPERATURE	12
DATE/TIME	12
DISPLAY TIME OUT.....	12
UTILITY MENU.....	13
FILE TYPE.....	13
TEMP MODE	13
DATE/TIME	14
DISPLAY	14
BATTERY TESTING – GETTING STARTED.....	15
BATTERY TEST SETUP	15
TEST SETUP	16
TEST/JAR.....	17
REFERENCE	21
TEST TYPE.....	22
SAVE	22
BATTERY TESTING – TAKING MEASUREMENTS	23
TEMPERATURE	23
PROBE PLACEMENT	23
HOW TO MEASURE STRAPS (INTER-CELL CONNECTORS)	25
TEST THE BATTERY/CELL FIRST.....	25
TESTING JARS AND 1 STRAP	25
TESTING JARS AND 2 STRAPS.....	26
TESTING JARS AND 3 STRAPS.....	28
TESTING SEQUENCE.....	31
DETERMINING A REFERENCE VALUE	32
BEFORE YOU TEST A STRING.....	32

OPTIONS IN DETERMINING A REFERENCE VALUE.....	32
TESTING A SAMPLE OF CELLS/BATTERIES	33
DATA MANAGER.....	34
UPDATING THE UNIT.....	34
UPDATING THE FIRMWARE	35

INTRODUCTION



SAFETY

GENERAL SAFETY PRECAUTIONS

1. IMPORTANT SAFETY INSTRUCTIONS:

IMPORTANT: IT IS OF UTMOST IMPORTANCE THAT BEFORE USING YOUR TESTER, YOU READ THIS MANUAL AND FOLLOW THE SAFETY AND OPERATING INSTRUCTIONS EXACTLY.

SAVE THESE INSTRUCTIONS.

RISK OF EXPLOSIVE GASES

Batteries generate explosive gases during normal operation, and when discharged or charged.

- 1.1 To reduce risk of battery explosion, follow these safety instructions and those published by the battery manufacturer and the manufacturer of any equipment you in-tend to use in the vicinity of a battery. Review cautionary marking on these products and on the battery cabinets, battery racks, battery rooms, and on the vehicle or equipment containing the battery.

NOTE: If you are uncertain as to the type of battery you are trying to test, contact the seller or battery manufacturer.

- 1.2 Do not operate the tester if it has received a sharp blow, been dropped or otherwise damaged in any way; contact Franklin Electric customer service.

- 1.3 Do not disassemble tester; contact Franklin Electric customer service when a repair is required. Incorrect reassembly may result in a risk of electric shock or fire.
- 1.4 Test batteries in a dry, well-ventilated area.
- 1.5 Do not expose the tester to rain or snow.

PERSONAL PRECAUTIONS

- 2.1 Always have someone within range of your voice, or close enough to come to your aid, when working around lead acid batteries.
- 2.2 Have plenty of fresh water and baking soda nearby in case battery acid contacts skin, clothing or eyes.
- 2.3 Refer to NFPA 70E for electrical safety PPE requirements.
- 2.4 If battery acid contacts skin or clothing, wash immediately with baking soda and water. If acid enters the eye, immediately flush with cold running water for at least 10 minutes, and seek medical attention.
- 2.5 Never smoke or allow a spark or flame in vicinity of a battery or engine.
- 2.6 Be extra cautious to reduce risk of dropping a metal tool onto the battery. It might spark or short circuit the battery or other electrical part that may cause an explosion.
- 2.7 Before working with a lead-acid battery, remove personal metal items such as rings, bracelets, necklaces, watches, etc. A lead-acid battery can produce a short circuit current high enough to weld such items causing a severe burn.

TESTING PRECAUTIONS

▲ IMPORTANT: READ THIS INSTRUCTION MANUAL BEFORE USING THE TESTER.

▲ WARNING: TO AVOID ELECTRIC SHOCK WHEN TESTING JARS, FOLLOW YOUR COMPANY'S SAFETY PRACTICES AND THESE GUIDELINES:

- Mandatory use of safety glasses with side shields in the vicinity of battery work per 29CFR1910.133 (OSHA).
- Wear protective rubber gloves.
- Wear a protective apron or shop coat.
- Perform service work only for which you have been trained.
- Do not disconnect the battery cables from power systems during the test without authorization.
- Do not place yourself in an electrical circuit.
- Avoid simultaneous contact with the jar and with frame racks or hardware that may be grounded.
- Battery posts, terminals, and related accessories contain lead and lead compounds, chemicals known to cause cancer and birth defects or other reproductive harm.

Wash hands after handling.

- Aprons (acid-resistant).

- Insulating blankets.
- On-site spill kits.
- Protective footwear.
- Clothing (e.g., voltage levels, level of corrosive protection, the amount of arc-flash protection provided).
- Insulated rescue hooks or other means for pulling personnel from live circuits.

ABOUT THE TESTER

The tester performs conductance testing on stationary batteries used in UPS systems, power utility, and telecommunications industries. Its advanced analysis and data management tools are designed for universal use in the following applications regardless of configuration:

- UPS Systems, 120, 220/240, 480, 600 volts
- Power Utility (Switching, SCADA, etc.)
- Telecommunications , – 48/+24 volts
- CATV, 12, 24, 36, 48 volts
- The tester features a backlit graphical LCD, a digital multimeter, and 2MB of memory for data storage and transfer to a PC. The tester software includes an icon-based menu and pre-loaded data on over 250 battery models to expedite testing and record-keeping.

TEST CAPABILITY

The tester tests lead-acid and Ni-Cd batteries and cells with nominal voltages of; 1, 2, 4, 6, 8, 12, 16, and 18 VDC. The tester can test batteries providing power to a load (in service) or not providing power (not in service).

MEASUREMENTS

The tester measures the status of a cell/battery in voltage, conductance, and temperature values. It displays conductance values in Siemens (S). Ampere hours (Ah) are a typical measurement of cell/battery capacity; however, they are difficult to measure without knowing the load to which the cells/batteries supply power. Franklin Electric recommends that you compare test results to a conductance reference value. See section on “Determining a Reference Value” for more information about reference values.

TEST RANGE

The tester has an operating range of 0 to 20,000 S. This range includes cells/batteries that have about 10 to 6000 Ah of reserve capacity.

DATA STORAGE

The tester’s flash memory can store up to 2MB of hierarchy structure and test data.

SPECIFICATIONS

Applications

Tests individual Lead-Acid or Nickel-Cadmium cells or Monoblocs (up to 18V) in any common configuration, approximately 10-6000Ah.

Voltage Range

1.0 – 20.0 VDC

Conductance Range

100 – 19,990 Siemens

Test Data Storage

2MB

Accuracy

+/-2% across test range, Voltage and Conductance

Voltmeter Resolution

5mV

User Programmable Functions

- Preset values for over 250 battery types
- Low voltage alarm setting
- Low conductance warning
- Low conductance alarms
- Test mode (push button/auto start)

Keypad

Alpha-numeric, Stainless-steel dome, Polycarbonate overlay, 1,000,000 actuations

Data Transfer

- USB Flash Drive (Type A)
- USB PC Interface (Type B)
- Infra-red, half-duplex IRDA Protocol for printer
- WiFi

Environmental Operating Temperature Storage Temperature

0 to+40°C, 95% relative humidity, non-condensing
-20 to 82°C

Over Voltage Protection

- Protected up to 600 VDC
- Auto-reset disconnect
- Reverse polarity protected

Calibration

Franklin Electric will work with each customer to establish a regular calibration program if it is required by their quality or other management system.

Cable Options

- Dual contact clamps
- Dual contact probes

Power Requirements

7.2V, 2500mAh, NiMH Internal exchangeable battery & charger

Display

LCD- FST 2.97 in x 2.81 in (75.4 mm x 71.3mm), 128 x 128 pixels, 40 degree viewing angle, contrast ratio8, LED backlight

Tester Dimensions

11in x 4in x 3in
(280mm x 105mm x 80mm)

Tester Weight

1 Kg/2.6 lbs.

PRODUCT MAP

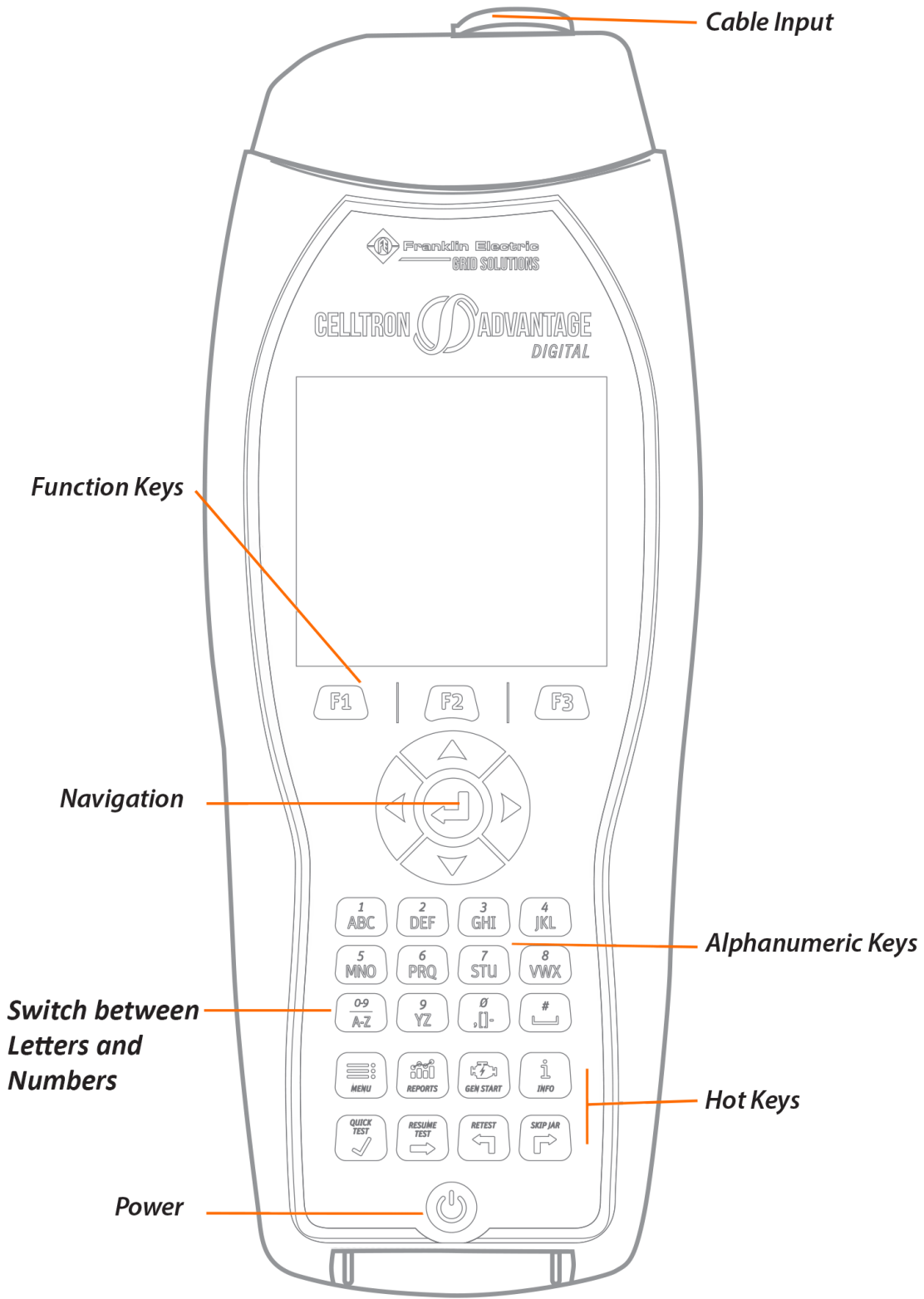

TOP

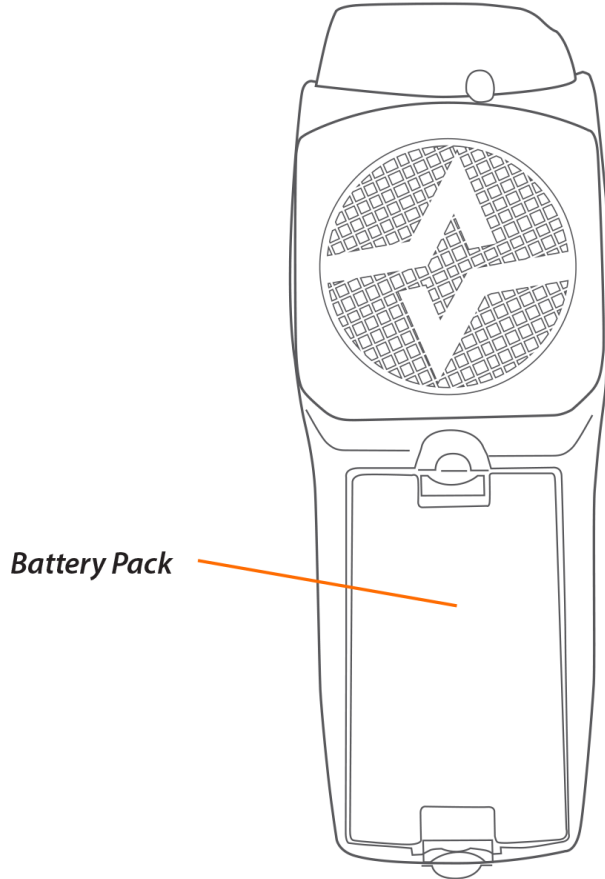
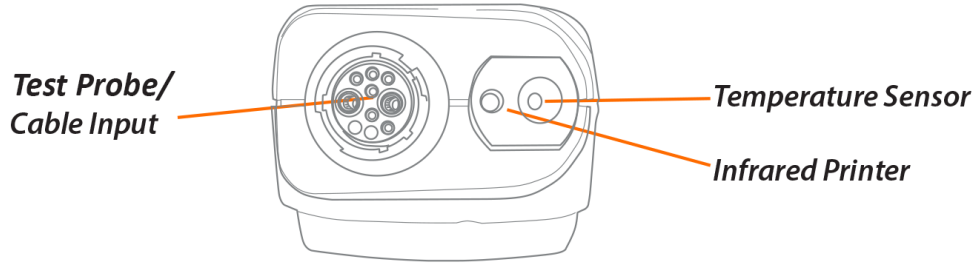

BOTTOM

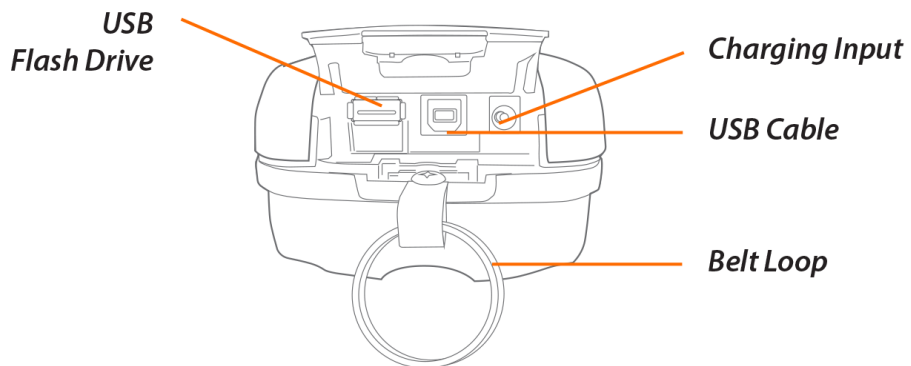

NAVIGATION HELP/QUICK NAVIGATION

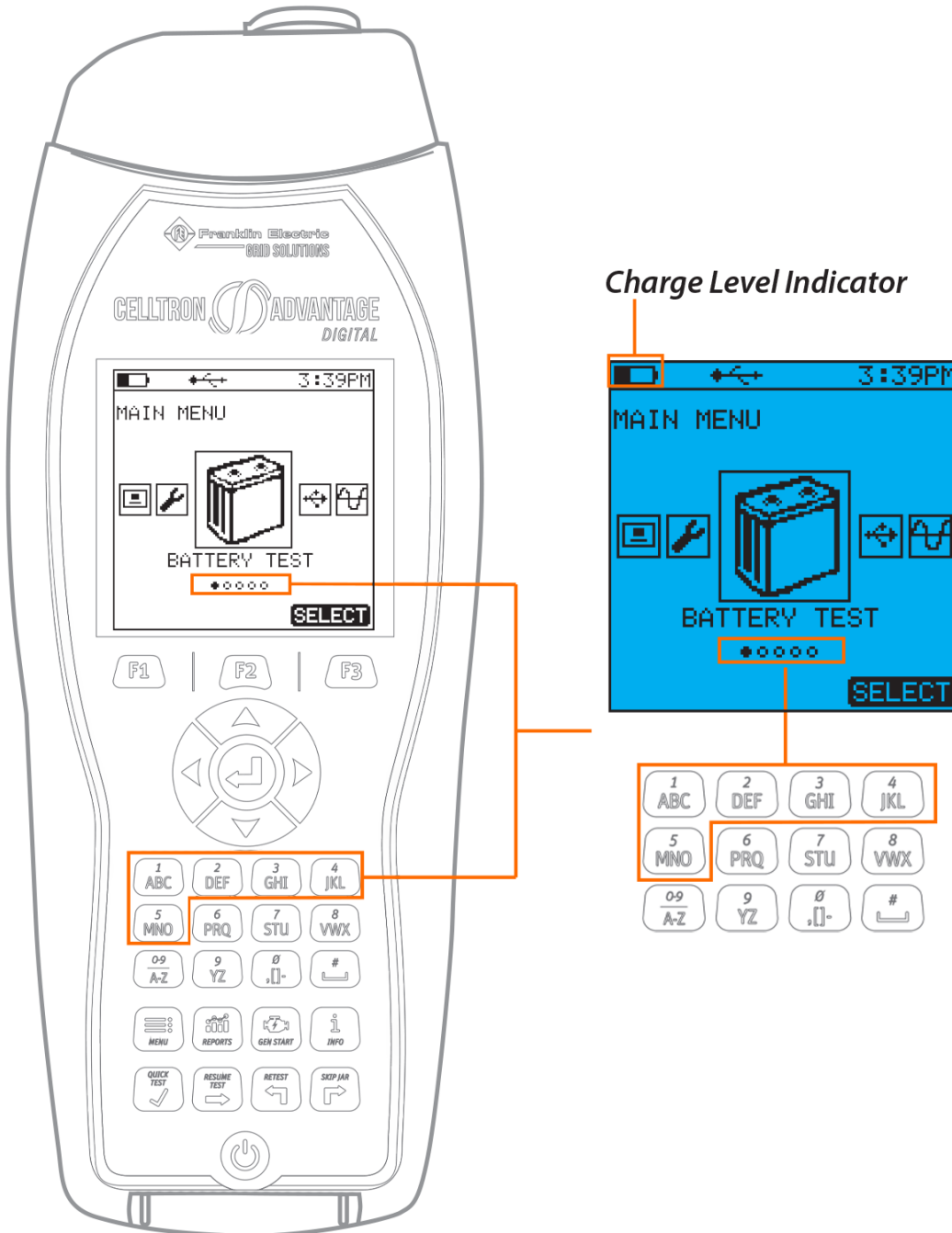

The numbers of dots on the menu screen (as highlighted) represent the sections of your tester. To quickly navigate thru these option, without having to continuously use the Navigation Buttons, you can use the number pad to get to the screen you want.

This quick navigation feature can be used anywhere in your tester.

HOT KEYS

Using the Quick Keys, you will be able to easily perform a function.



The Main Menu key allows a quick return to the main menu and all of its functions.



The Reports key generates the report options from both past and present battery tests.



The Gen Start activates the function (optional) to test a generator or engine start battery.



The Info key lists tester information



The Quick Test bypasses the base setup information for testing a cell, unit, jar, or battery. This allows you to perform a single test; the test results can be viewed on the screen but are not saved or stored.



The Resume Test key resumes an interrupted test.



The Retest key enables you to retest a cell, unit, jar, or battery that has been previously tested. (Normally due to a suspect reading)



The Skip Jar key enables you to put a placeholder of 0.000V and 0 conductance for a cell, unit, jar, battery, that is too low for the **CELLTRON ADVANTAGE** to test in the battery string.

MAIN MENU OVERVIEW

Using the “Main Menu” Quick Key, you will be able to navigate thru the options. Select your desired screen and press the  button. This will open up your options per screen/section. Choose desired function.



Main Menu Quick Key

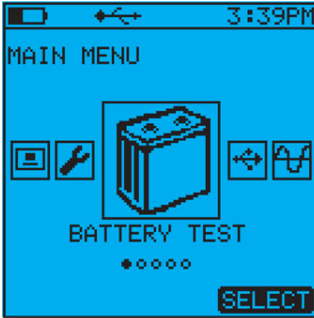

Begins the process of site, string, battery setup.

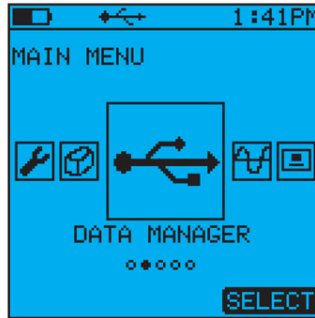

Transfer data to/from **CELLTRON ADVANTAGE**

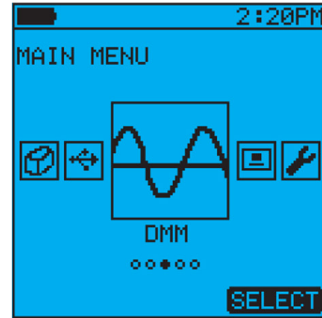

DC Voltage Measurement.

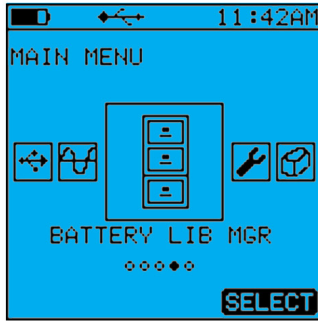

Internal battery reference base.

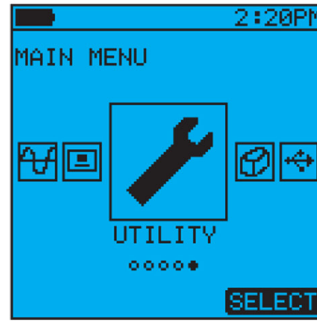

Utility setting for system including temperature, scale, clock, day/date, etc.

Utilizing the following screens you can choose the desired function you wish to perform.

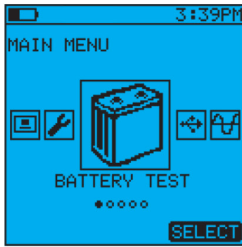

Site Setup: For a standard battery test, you will setup a site. For a breakdown of this procedure, please reference page 12, Performing a Battery Test.

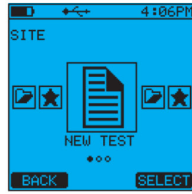

Allows you to create a new battery setup.

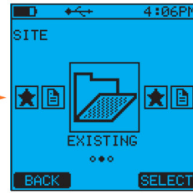

Allows you to use existing sites.

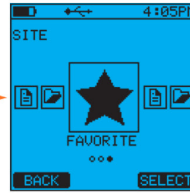

Pick your favorite site and plant from Utilities Menu

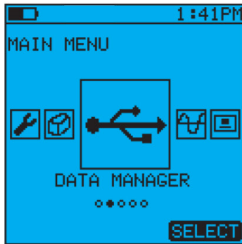

Data Manager: Allows the upload, download, and deletion of data.

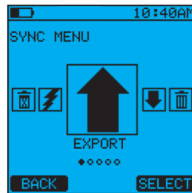

Upload your test results via USB flash drive to CELLTRAQ.

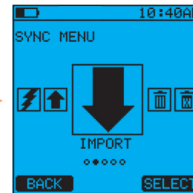

Download your test results via USB flash drive from CELLTRAQ.

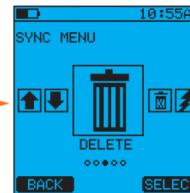

Delete old or unwanted results.

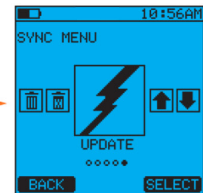

Enables you to update tester from file via USB.

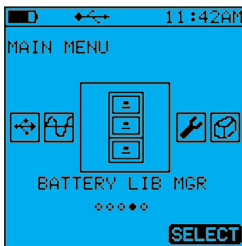

Battery Manager: Choose the manufacturer of the battery you are testing

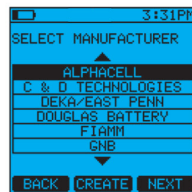

This screen allows you to choose the manufacturer of the battery you are testing.

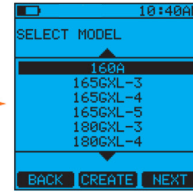

Choose model.

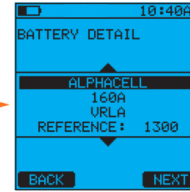

Configure detail.

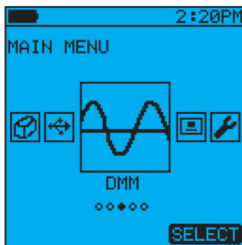

DMM Multi-meter: Allows the DMM multimeter Function.

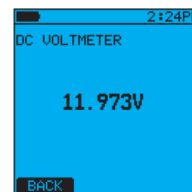

Typical DC Volts measurement.

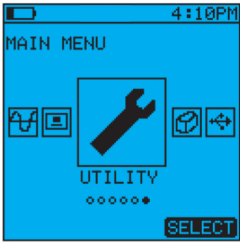

Utility: Helps you set the way you want your **CELLTRON ADVANTAGE** to function.

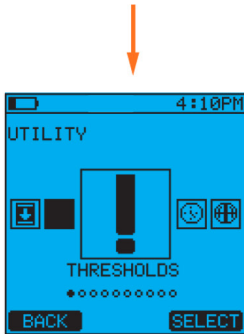

Set tester thresholds for voltage, conductance, and temperature.

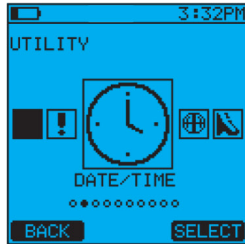

Set the date and time.



Choose preferred language.

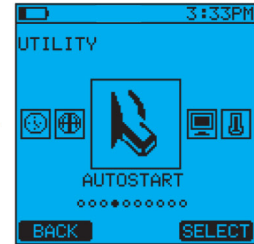

Sets tester to activate test process on contact.

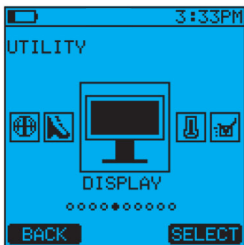

Set display brightness, contrast, etc.

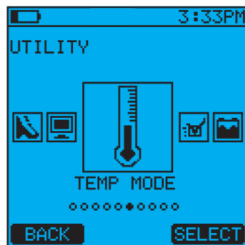

Set temperature mode: per jar or per string.

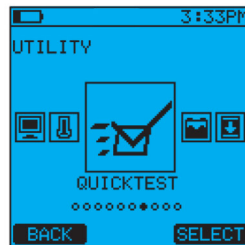

Enables you to start a test on a single cell or monoblock without first setting up a site.

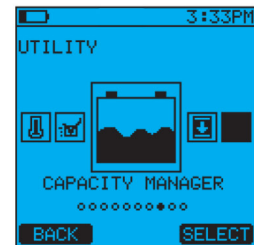

Enables you to record cell voltages on a timed interval during a capacity load test.

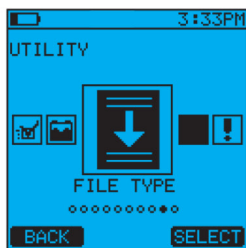

File type selection for exporting data use w/ **CELLTRAQ EXPRESS** or **CELLTRAQ ENTERPRISE**

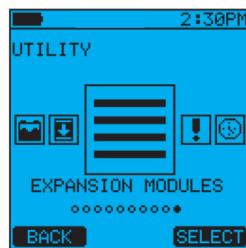

Select and activate additional capabilities of the **CELLTRON ADVANTAGE**.



Set up a favorite for quick access.

SETUP

Items to setup when you first receive the tester.

FILE TYPE

- CELLTRAQ™
- Excel (.csv)
- Both

TEMPERATURE

- Units
 - Celsius
 - Fahrenheit
- Test Mode
 - Measure each jar.
 - One temperature for all.
- Edit Temperature
 - Disable
 - Enable

DATE/TIME

- Set the unit to the correct local time.

DISPLAY TIME OUT

You can set this to 1 to 10 minutes. 10 minutes is recommended.

UTILITY MENU

FILE TYPE

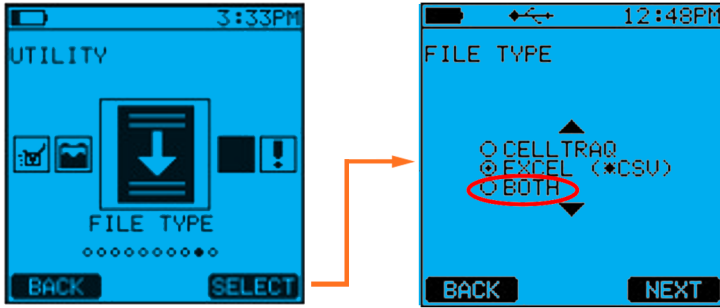

File type selection for exporting data used w/ **CELLTRAQ EXPRESS** or **CELLTRAQ ENTERPRISE**

F3

TEMP MODE

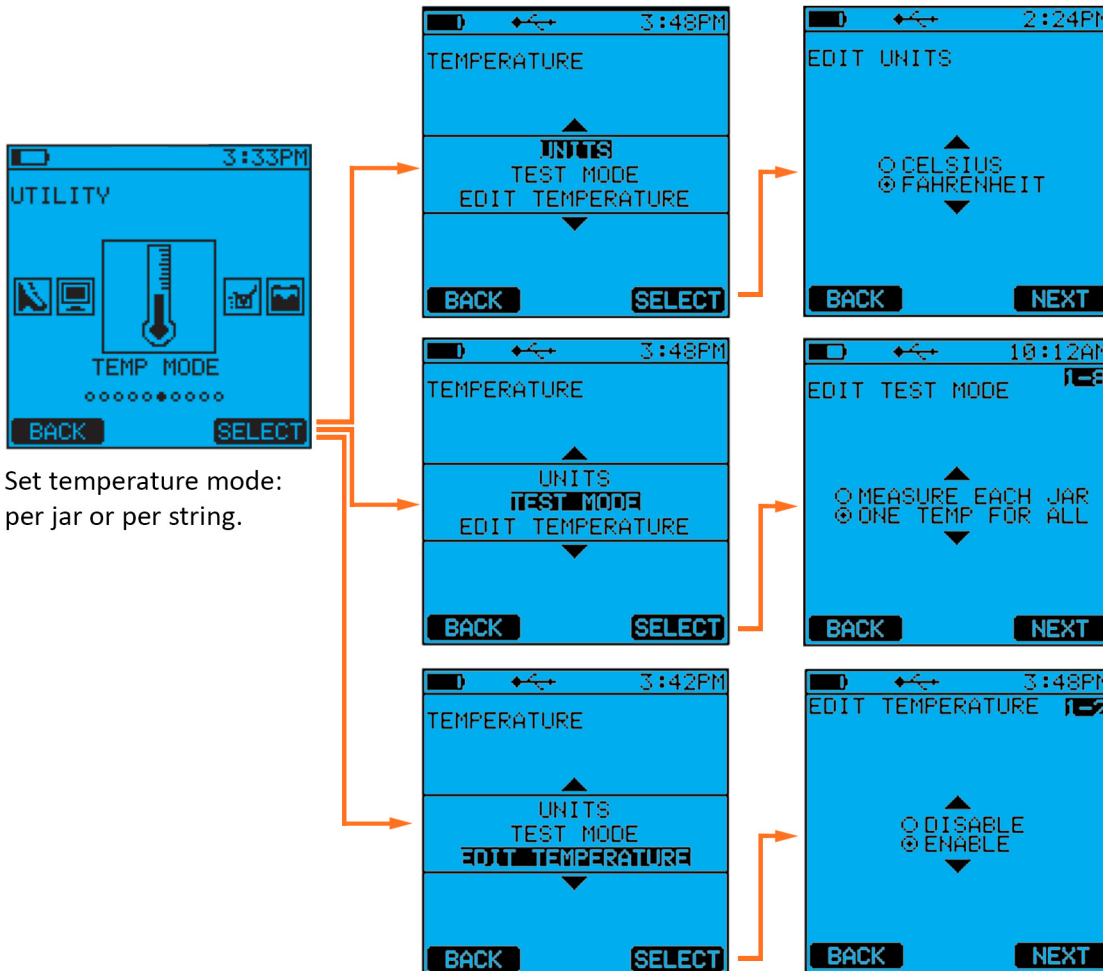

Set temperature mode: per jar or per string.

Enables temperature values to be edited after measurement.

DATE/TIME

Units ship set to USA Central Time Zone.

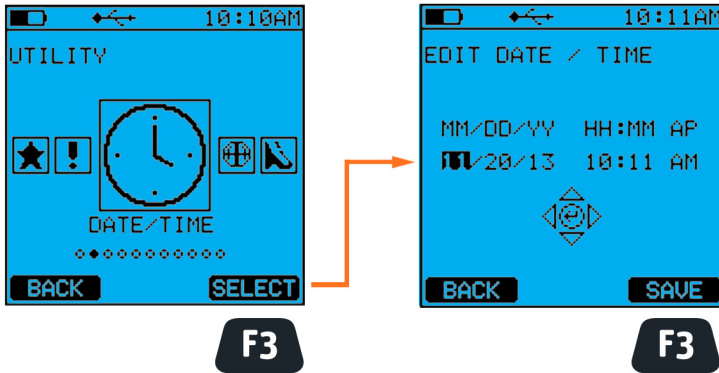

DISPLAY

Changing the Time-Out:

1. Go to the main menu.
2. Go to UTILITY, and press F3 to choose SELECT.
3. Go to DISPLAY, and press F3 to choose SELECT.
4. Scroll to TIME-OUT in EDIT DISPLAY. Press F3 to choose SELECT.
5. Scroll to your desired time-out (10 minutes, "10M," is recommended) in EDIT TIME-OUT. Press F3 to choose SELECT.

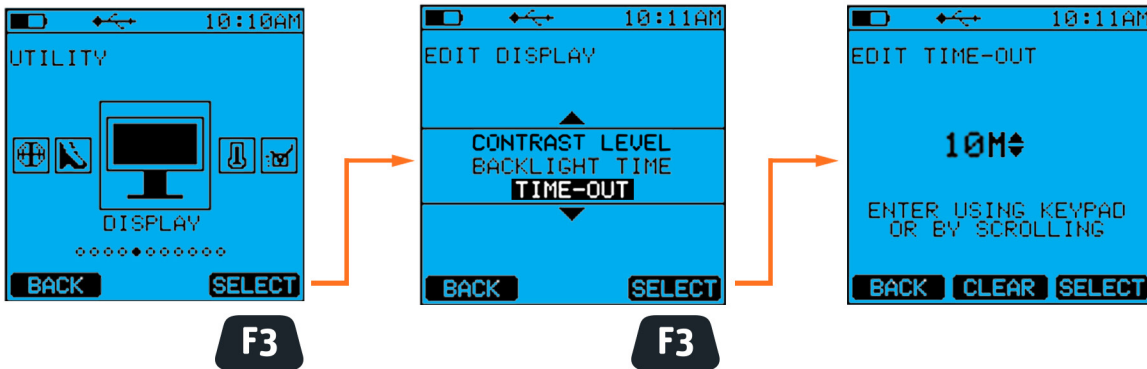

BATTERY TESTING – GETTING STARTED

BATTERY TEST SETUP

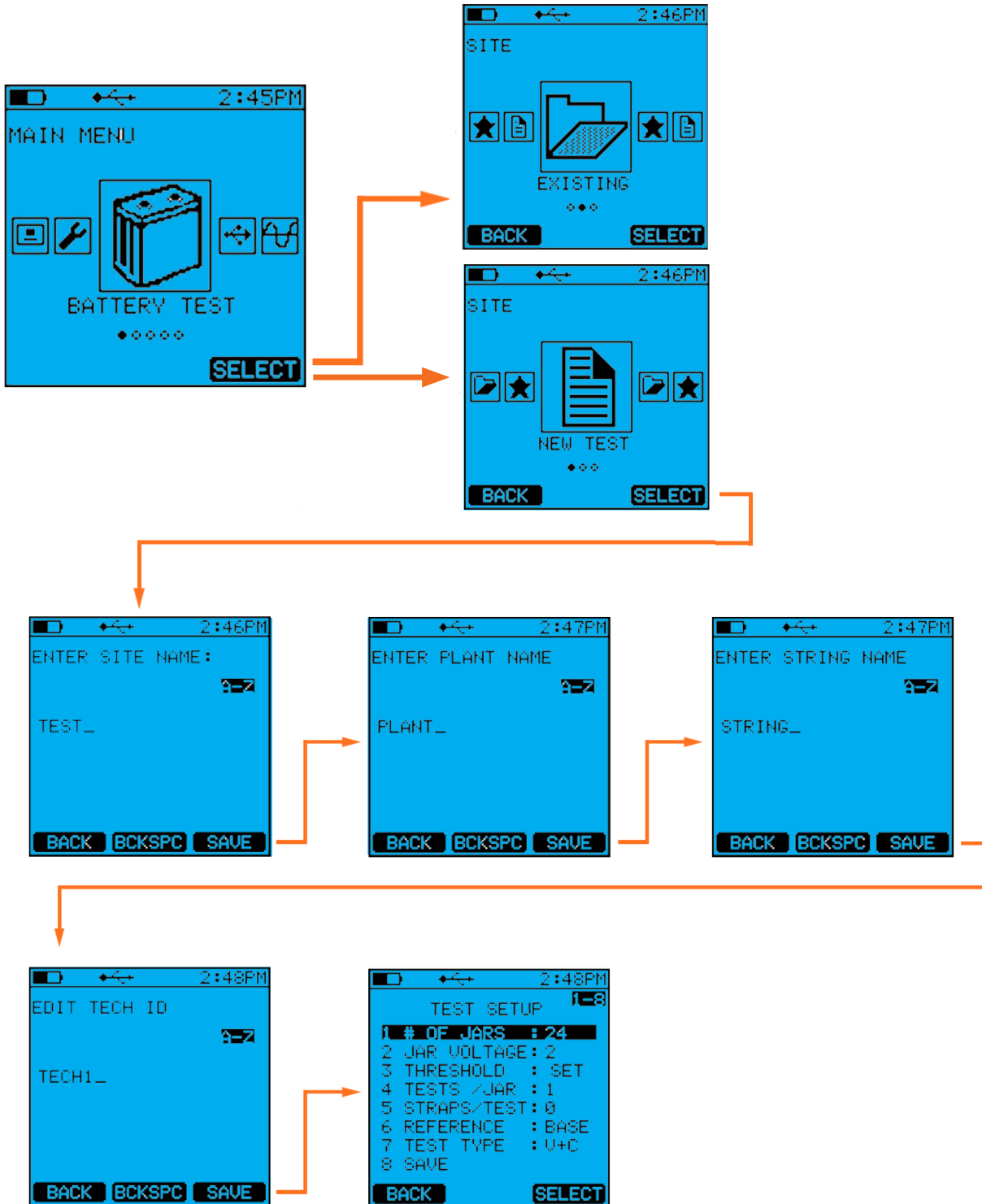

TEST SETUP

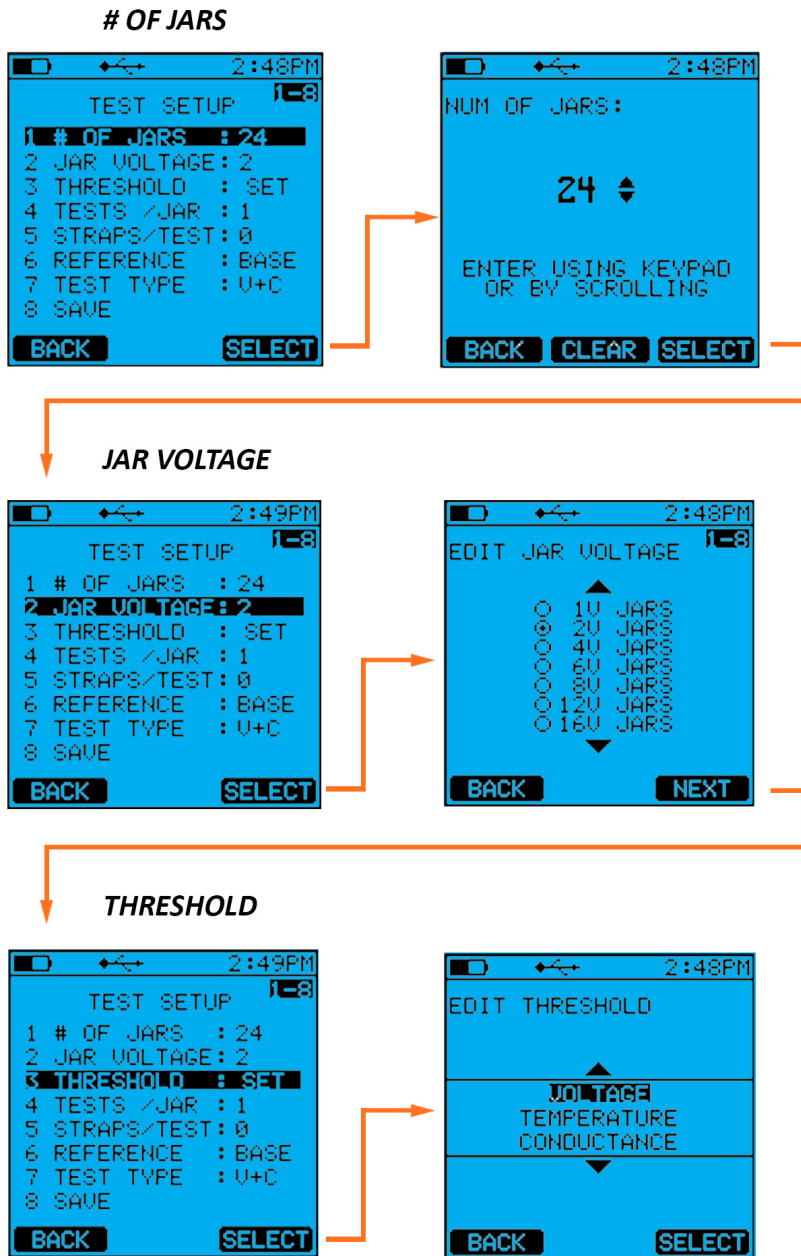

TEST/JAR



Setting Up Test per Jar:

- Test per Jar = 1 and No Strap Tests

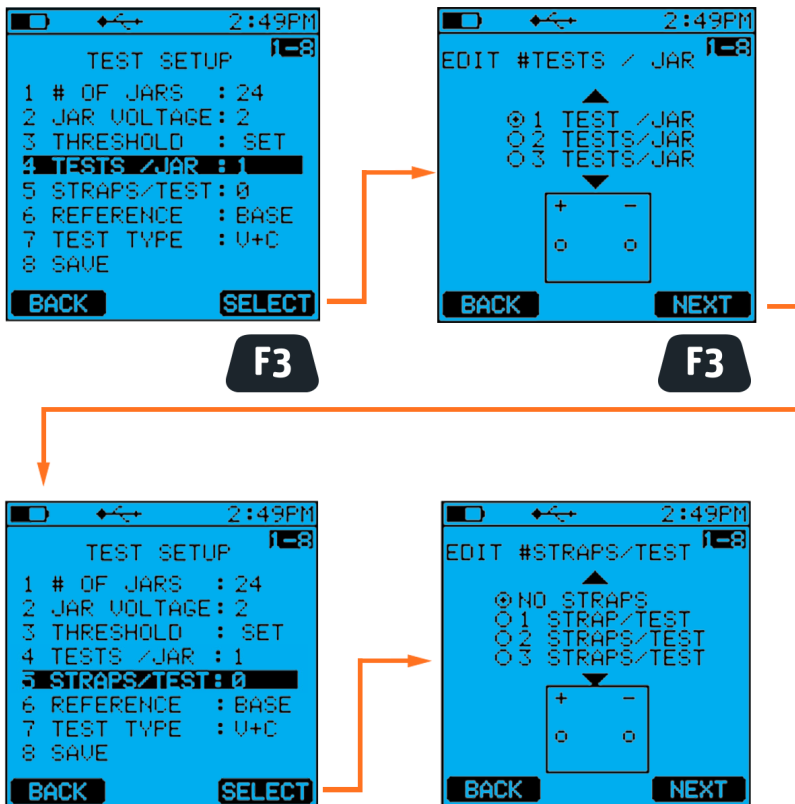

- Test per Jar = 1 and 1 Strap test per jar.

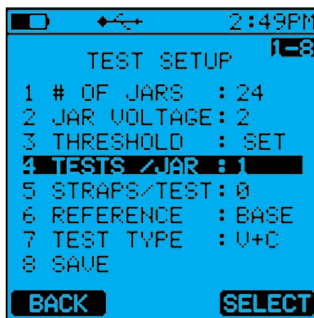

F3

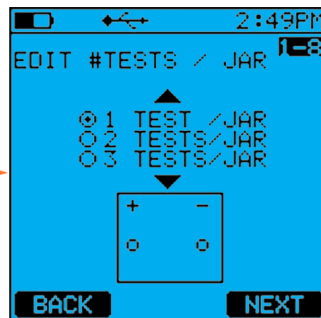

F3

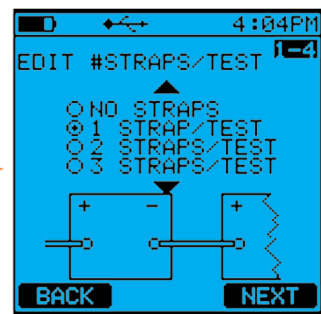
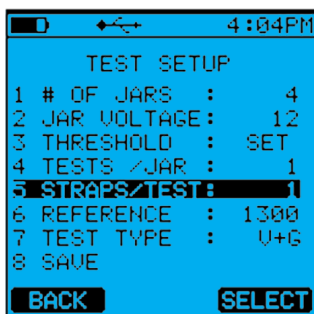

- Test per Jar = 1 and 2 Strap test per jar

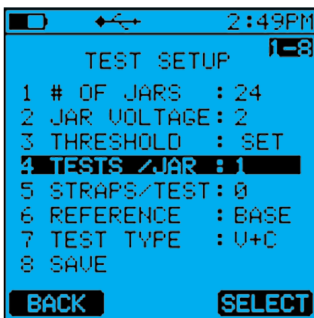
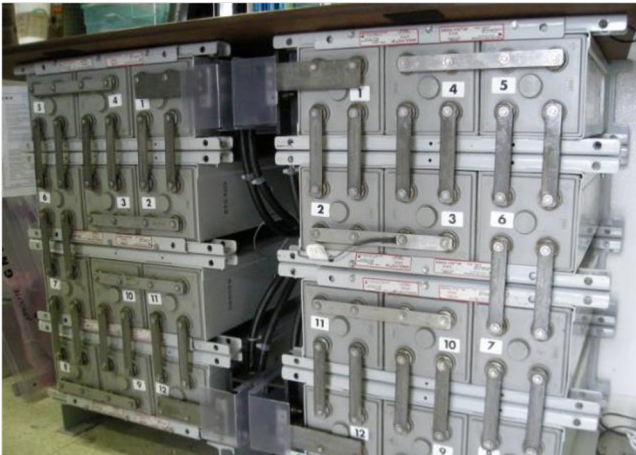

F3

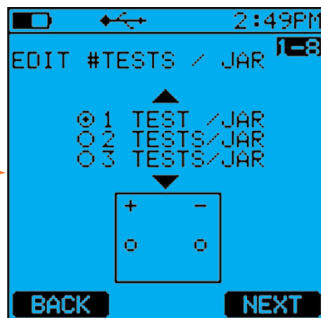

F3

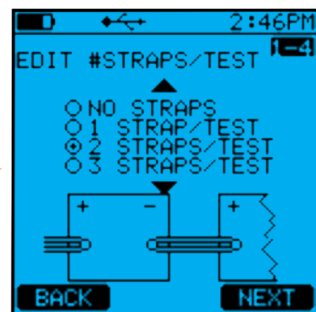

- Test per Jar = 1 and 3 Strap test per jar

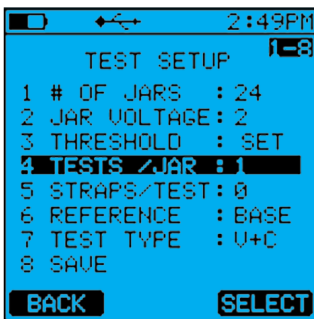

F3

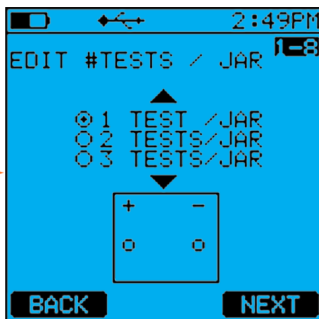

F3

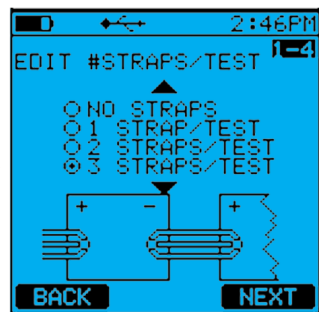
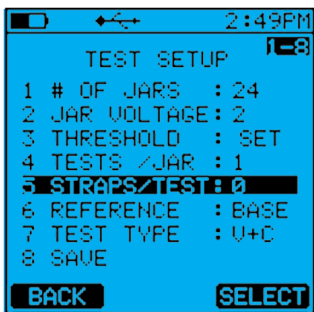

REFERENCE

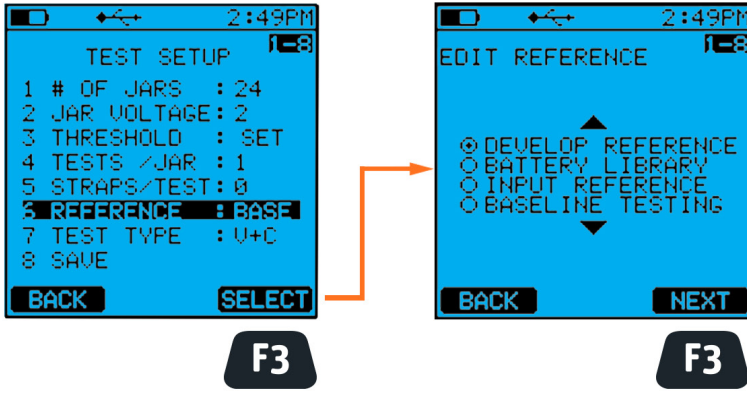

Reference Options

Option	Description	Best Use
Develop Reference	By default, uses the top 30% of the measurements to establish a reference value (% can be adjusted to your preference).	Within the first quarter of a battery's life.
Battery Library	Contains a list of reference values established by battery manufacturers, end users, and field service engineers.	For older installations when no previous data is available.
Input Reference	Allows the user to manually enter a reference value.	When you have a known good value based on previous history of similar installations or from your company's own reference value list .
Baseline Testing	A reference value will be established based on the average of all the conductance readings within a string.	For cells/batteries installations that are new to 180 days old.

TEST TYPE

- Voltage Only (V)
 - Measures and records the voltage only.
- Volts and Conductance (V+G)
 - Measures and records the voltage and conductance at the same time.
- Volts then Conductance (V>G)
 - Measures and records all the voltages first, and then starts again at cell/battery number one to measure and record all the conductance readings. At the end of the conductance testing the voltage and conductance readings will be paired up for each cell/battery (this mode addresses “voltage creep”).

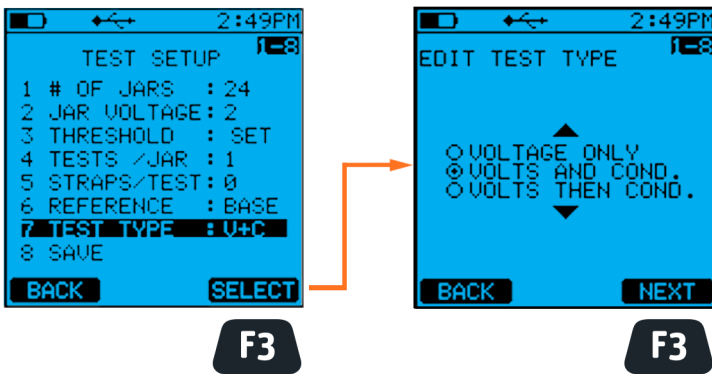

SAVE

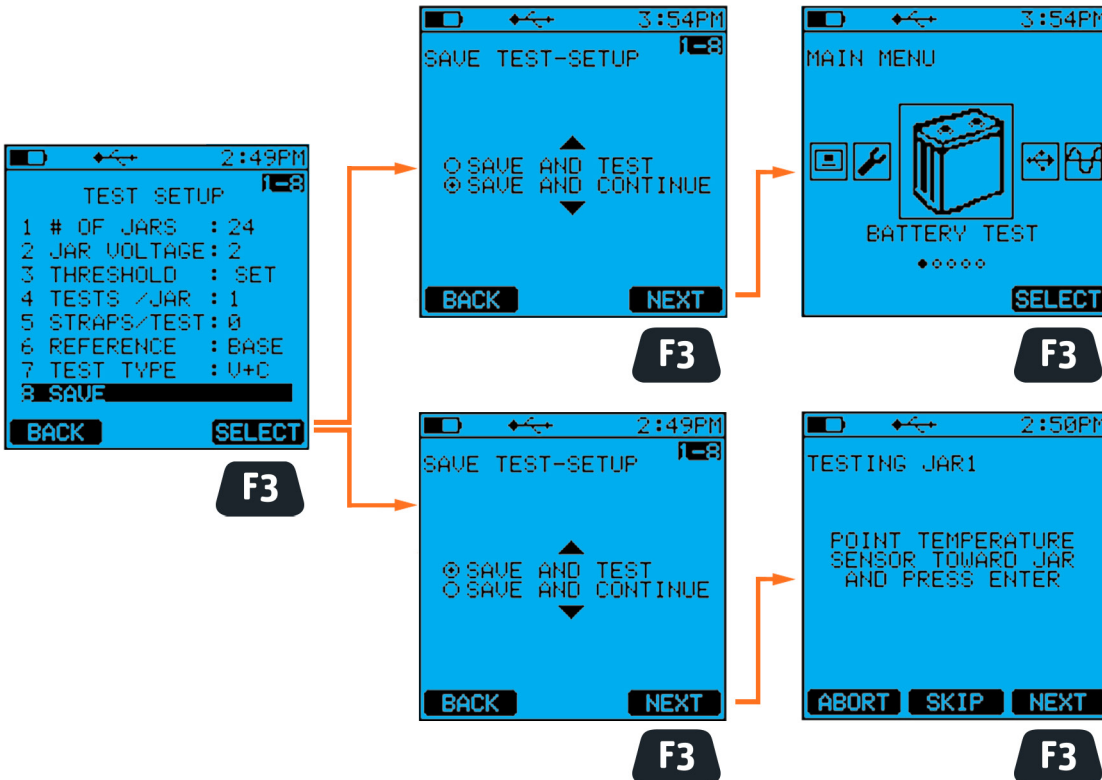

BATTERY TESTING – TAKING MEASUREMENTS

TEMPERATURE

Recommendations for taking temperature measurements with the Advantage:

1. Hold the Advantage as close to the negative battery terminal as possible, less than or equal to 2.5" (6.35 cm).
2. Hold the Advantage such that its temperature sensor is at a right angle (exactly perpendicular) to the negative battery terminal
3. If the battery terminal is less than 2.5" (6.35 cm) spot size, measure the top surface or case temperature of the battery
4. Temperature measurements should be made with the object and tester at approximately the same temperature. When testing batteries in a cold environment, 0°C to 15°C, the tester should be allowed to equilibrate for about 20 minutes. When testing in a hot environment, 30°C to 40°C, the tester should also equilibrate for about 20 minutes.

PROBE PLACEMENT

BE CONSISTENT.

If you cannot access the terminal post, test on the strap as close to the terminal as possible.

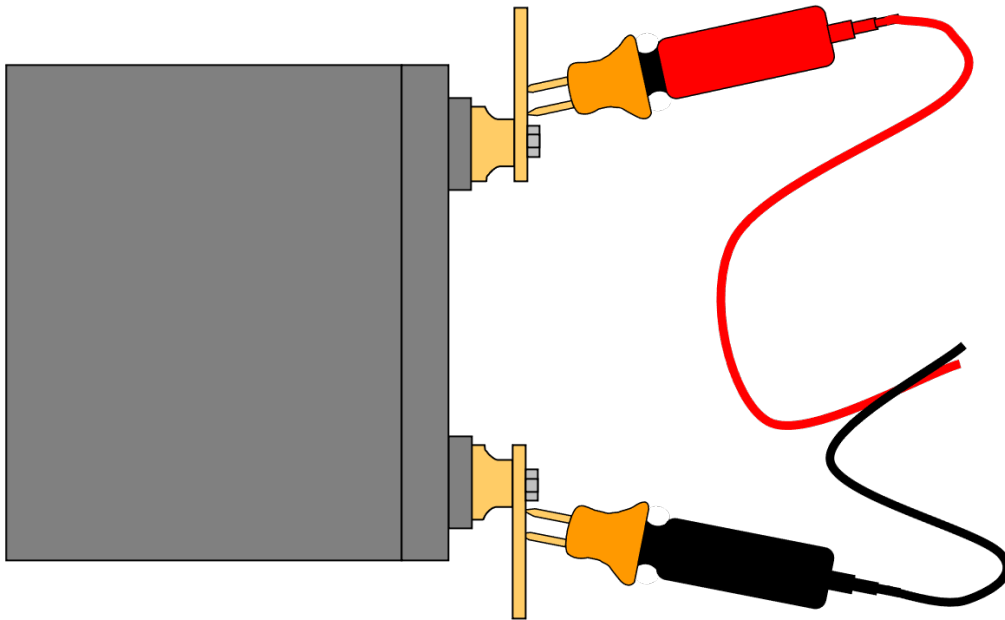

NOTE: Always try to avoid testing on stainless steel battery hardware. Testing on stainless steel will alter ohmic measurements since stainless has resistive properties.

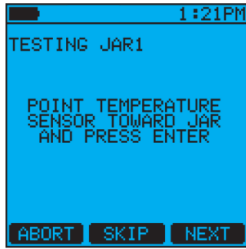

Site Setup: To begin testing, a battery temperature must be taken. It is recommended that the measurement be taken close to the negative post.

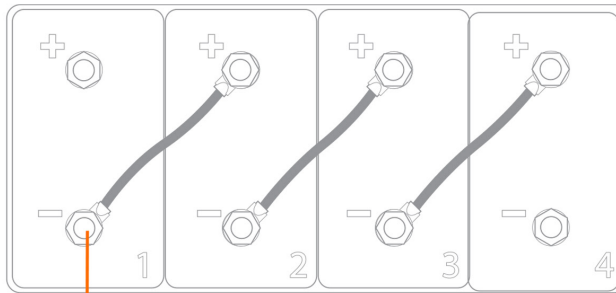

Preferred Method:
Start with battery on top of stack.

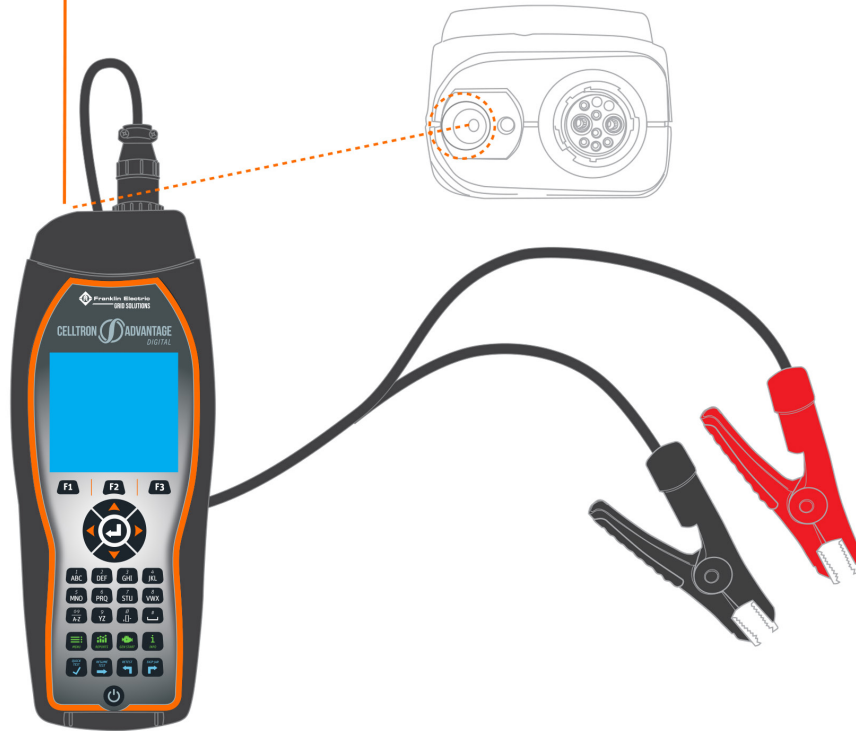

HOW TO MEASURE STRAPS (INTER-CELL CONNECTORS)

TEST THE BATTERY/CELL FIRST

TESTING JARS AND 1 STRAP

OPTION 4:

Set the tester for the TESTS/JAR: 1

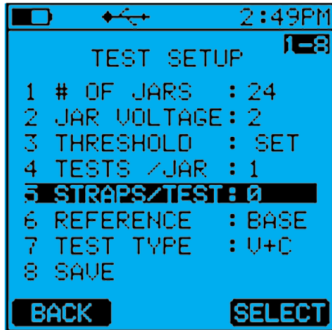

OPTION 5:

Set the tester for the STRAP/TEST: 1 (Set to strap 1)

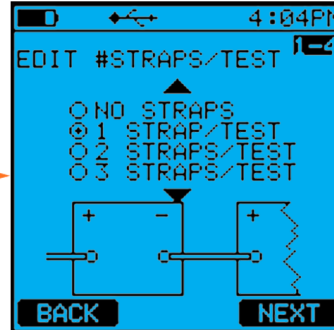

IMPORTANT: Test on inter-cell strap as close to the battery terminal as possible. Do not test on battery hardware (nuts and bolts).

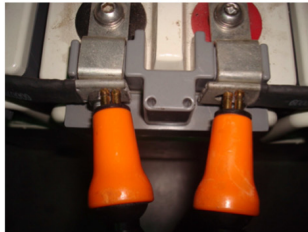

1. Test just the battery/cell.
 - a. Front terminal batteries.



2. Next, test the battery/cell plus the strap (inter-cell connection).
 - a. Battery 1, plus Strap 1



TESTING JARS AND 2 STRAPS

OPTION 4:
Set the tester for
the TESTS/JAR: 1



OPTION 5:
Set the tester for the STRAP/TEST: 2
(Set to strap 2)

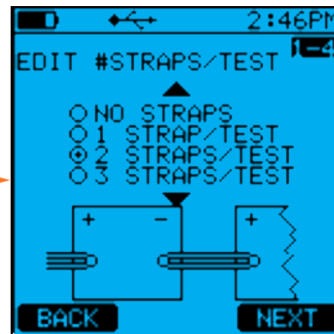

1. Test the cell on the diagonal terminals or inter-cell strap near the cell terminals.

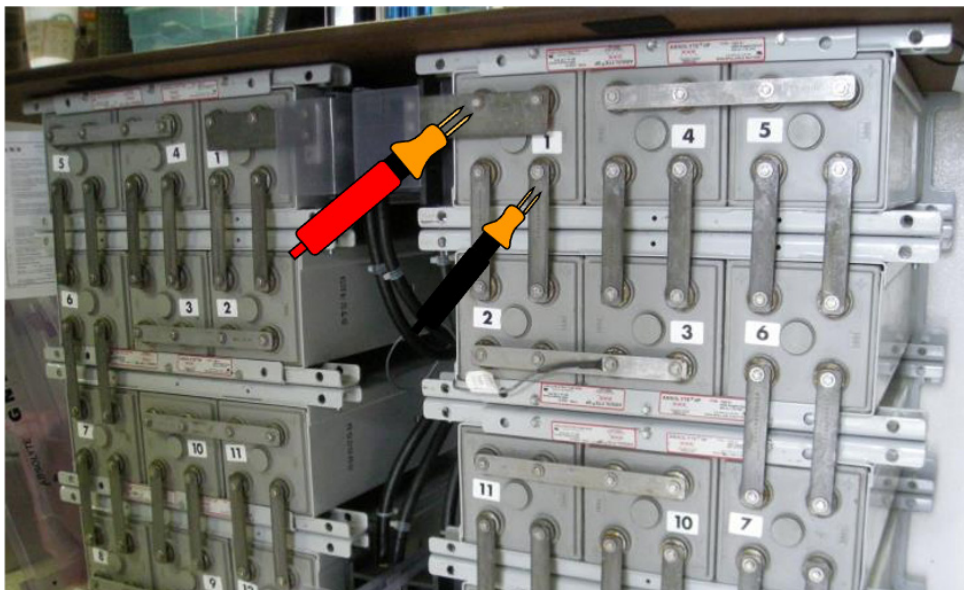

2. Next test the cell plus the first strap.

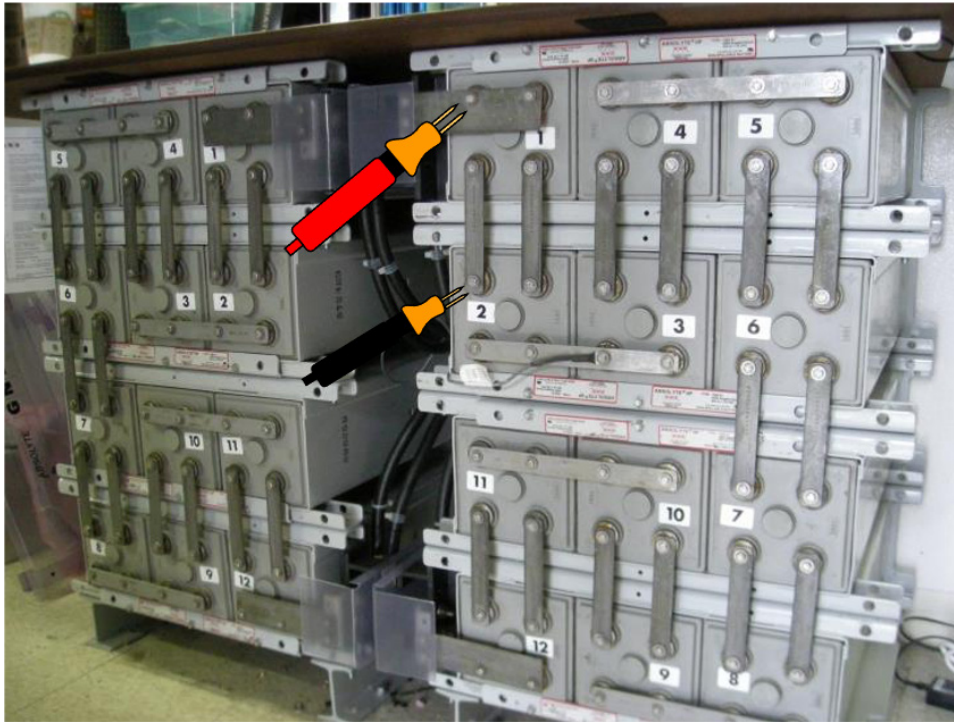

3. Next test the cell plus the second strap.

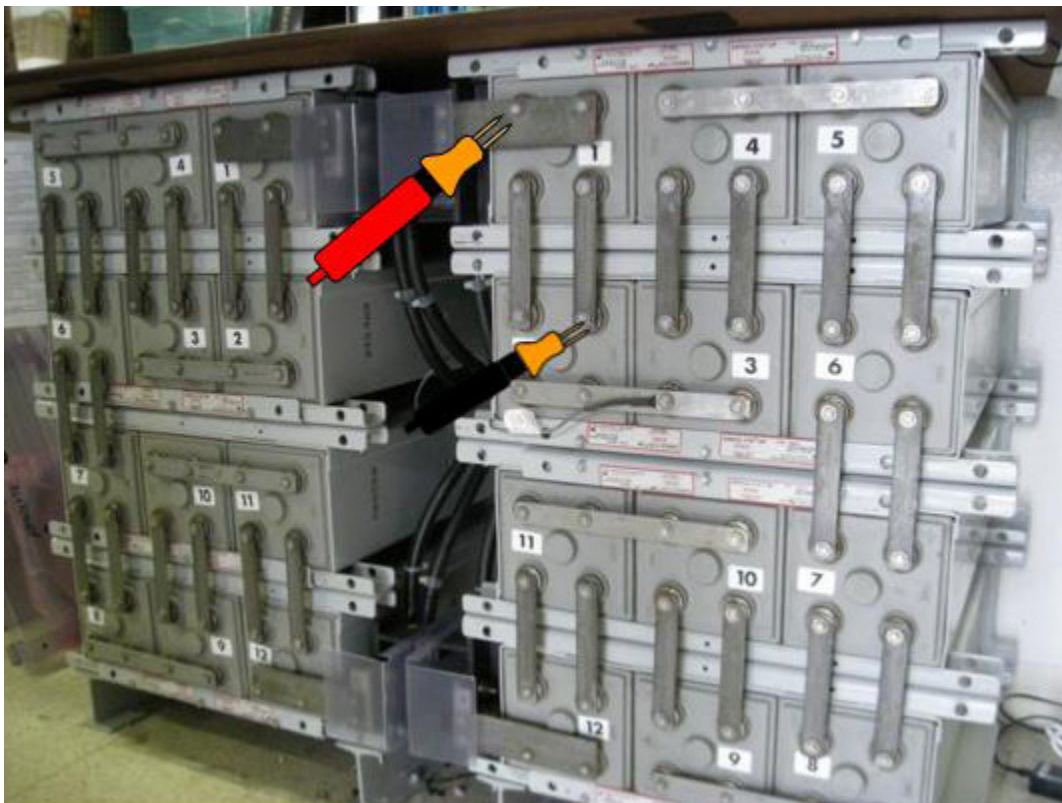

TESTING JARS AND 3 STRAPS

One cell with 6 battery terminals (three pair of terminals).

NOTE: This is just an example on how to take the measurements. When you test a battery string, start on cell one.

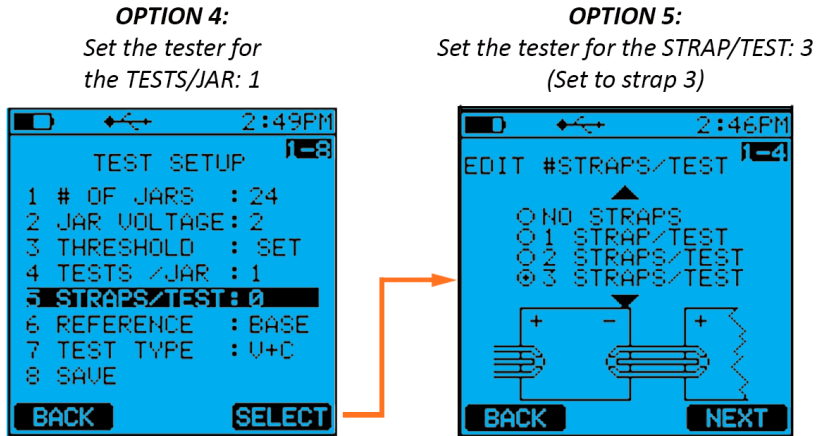

1. Test the cell first on the center terminals or inter-cell strap near the cell terminals.

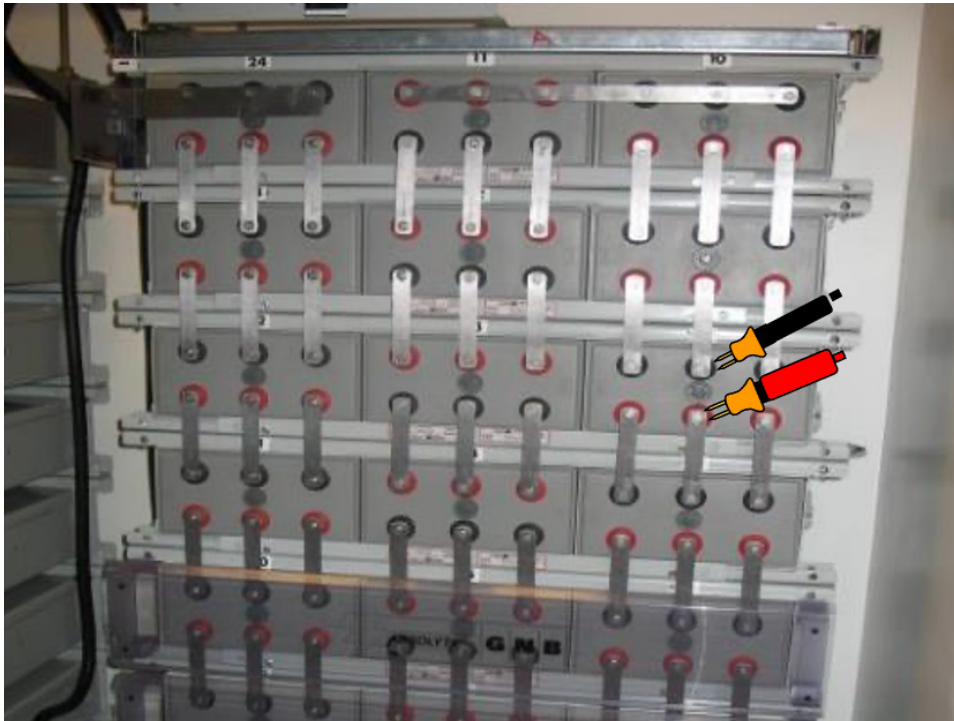

2. Next test the cell plus the first strap.

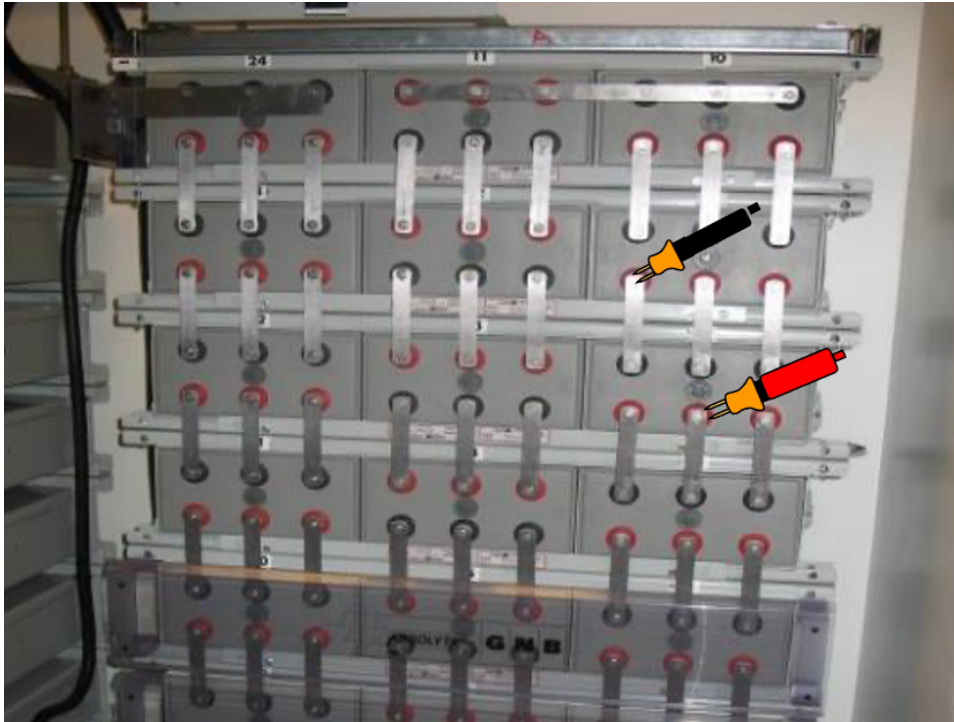

3. Next test the cell plus the second strap.

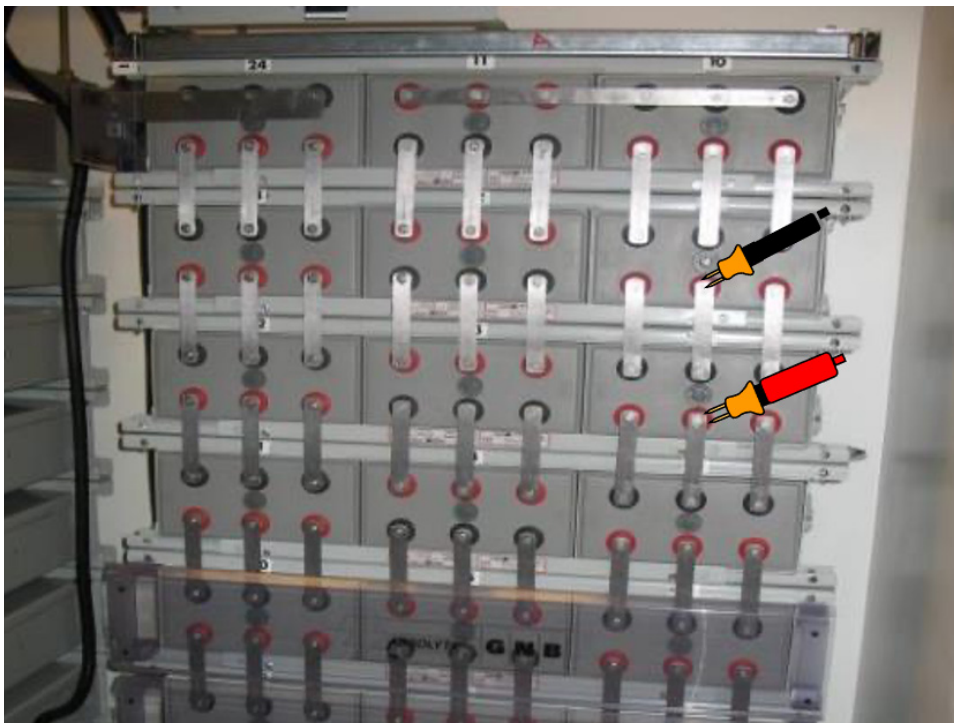

- Next test the cell plus the third strap.

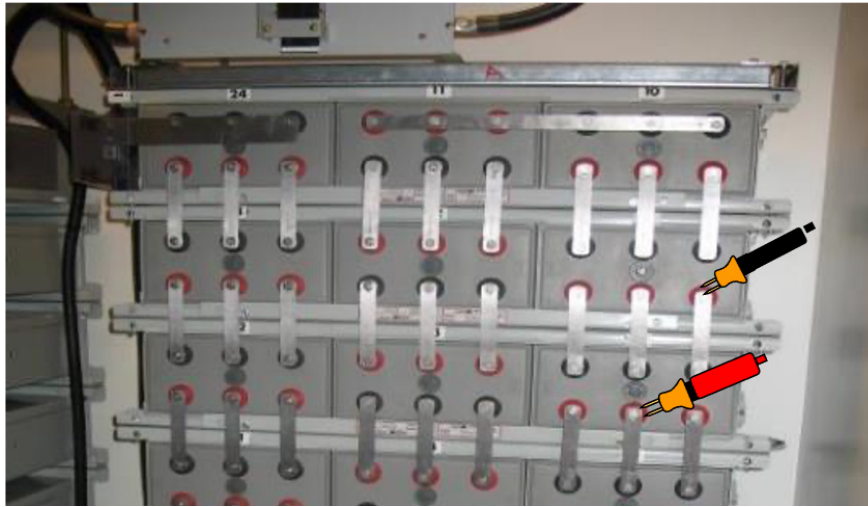

When testing a cell with two inter-cell straps per post you can test this as one strap since your contact point will encompass all the connections in the test signal path.

- Test the cell first on the lead posts.

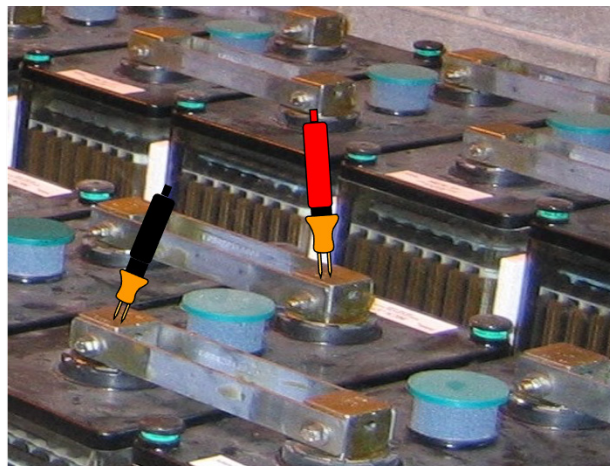

- Next test the cell plus the straps on the lead posts.

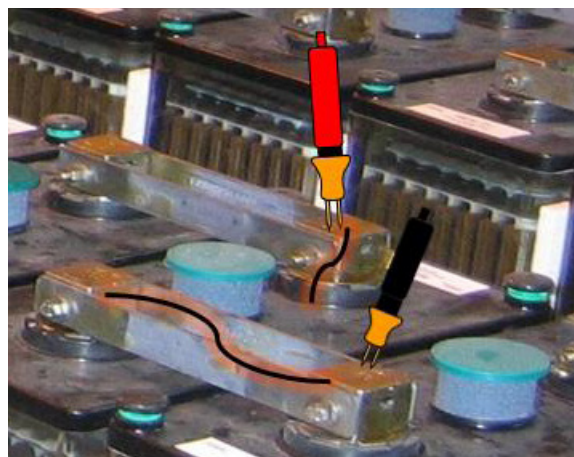

TESTING SEQUENCE

NOTE: A positive ground configuration does not cause polarity to change, plus (+) is still plus and carries a positive charge with respect to the negative (-) terminal or minus.

Follow the series connections from the most positive cell to the most negative cell.

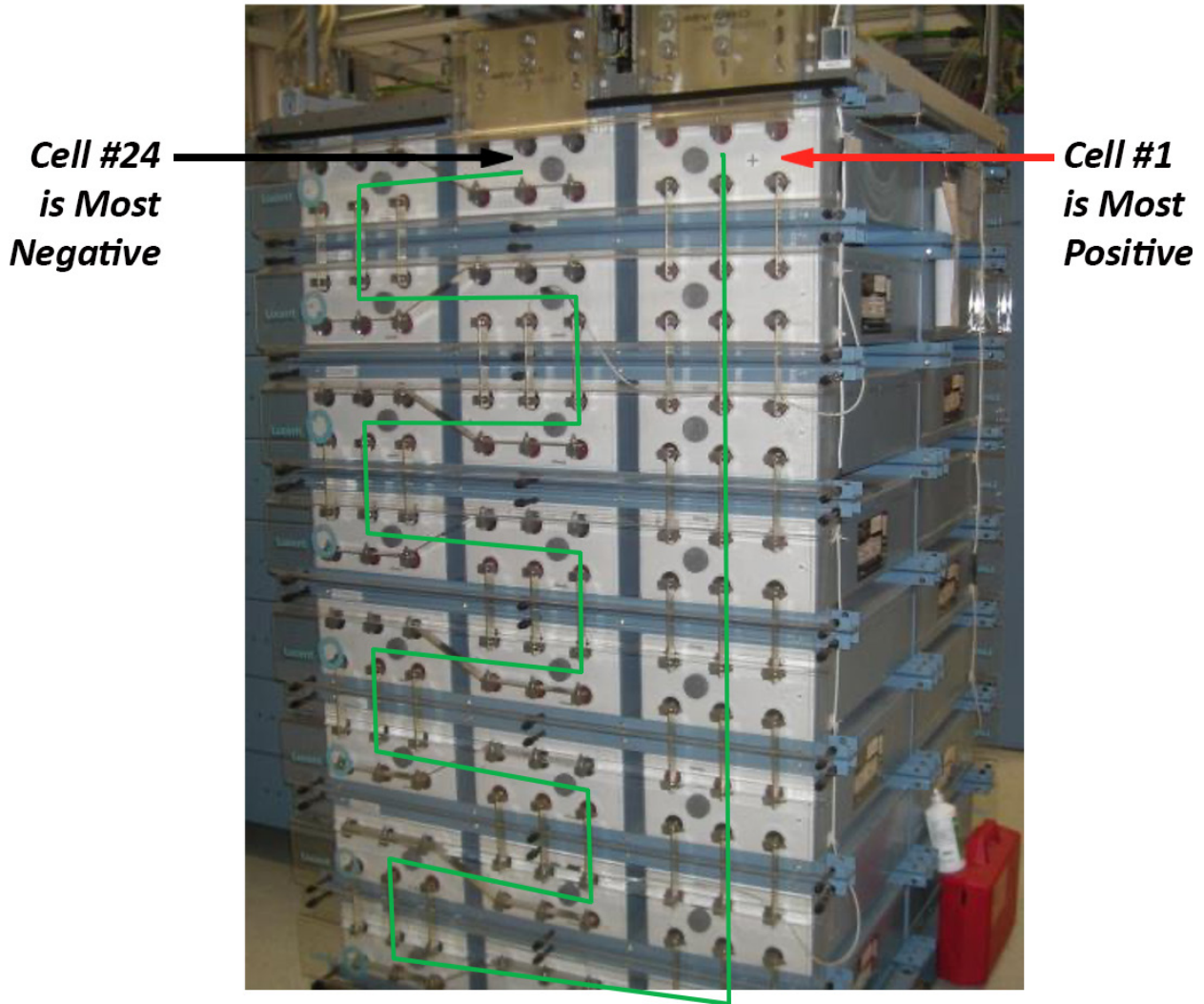

DETERMINING A REFERENCE VALUE

BEFORE YOU TEST A STRING

- Note the voltage of the cells/batteries
- Determine a reference value

Reference values are average conductance values from a sample of strong cells/batteries similar in condition and age. Generally, a sample of 30 new or healthy cells/batteries are tested to obtain a value representative of a new online battery 90 days after installation. You can compare reference values to test results from a string. The differences between test results and reference values help you determine the string's state of health, and a relationship to capacity, to provide enough conductance for the load. Differences can reflect how a string was treated, installed, maintained, or is aging.

OPTIONS IN DETERMINING A REFERENCE VALUE

If you want a value specific to the string you are testing, Franklin Electric recommends that you create your own reference value. The following options are listed in the order you should take to obtain a reference value.

- Consult your company documentation for reference values that were created for the string you are testing.
- Test a sample of cells/batteries. Refer to Testing a sample of cells/batteries to establish a reference value.
- Use DEVELOP REFERENCE to determine a reference value based on a selected percentage (30% is the default) of cells/batteries on the string with the highest conductance value.
- Use BASELINE TESTING to determine a reference value. A reference value will be established based on the average of all the conductance readings within a string.
- Use the average from STRING SUMMARY > JAR AVERAGES > JAR G after you test the string.
- Use the reference value in the BATTERY LIBRARY MANAGER database for the model of cell/battery you are testing. If the model is not in the database, contact the battery manufacturer or visit, <https://franklingrid.com/support--reference-values/> for a list of reference values for common cell/battery types.

The reference values in STRING SUMMARY, BATTERY LIBRARY MANAGER, and on the website are only guidelines. Franklin Electric updates the website with new reference values when they are created. If you create a reference value for a cell/battery model, **e-mail the value and information to FFSTechSupport@franklinfueling.com Attn: Reference value list**).

CAUTION: Do not use the tester to test the entire string at once. Test only individual cells/batteries.

IMPORTANT: Always test on the lead post for the most consistent results. To prevent lower measures, avoid tests on stainless-steel hardware or bolts.

Note: Power outages can affect test results. Do not test the string if a power outage occurred recently and the string is boost-charging (equalize charge mode). Wait 48 hours to allow battery string to return to equilibrium after a power outage and recharge has occurred.

TESTING A SAMPLE OF CELLS/BATTERIES

1. Choose at least 30 cells/batteries from one manufacturer with the same make, model, power rating, age (within 6 months), and service history.
2. Record this information about the cells/batteries:
 - a. Cell/battery manufacturer
 - b. Model number
 - c. Date of manufacture
 - d. Date of installation
 - e. Condition in which the cell/battery operates, such as charge voltage (volts per cell), temperature, and DC float current through the battery string
 - f. Visible warnings, such as leaking acid, corrosion, or distorted cell/battery cases
3. Test the cells/batteries
4. Test one cell/battery 5 times in a row on float charge. Conductance results should be within $\pm 2\%$ of each other.

NOTE: If the test results do not conform to this pattern, an electrical signal might be present in the system.

5. Calculate the average conductance of the cells/batteries. Do not include cells/batteries that are higher or lower than 30% from the average because they might be outside an acceptable range.

DATA MANAGER

UPDATING THE UNIT

NOTE: When performing an update make sure your battery is fully charged!

NOTE: Once the update is complete, the tester turns off automatically.

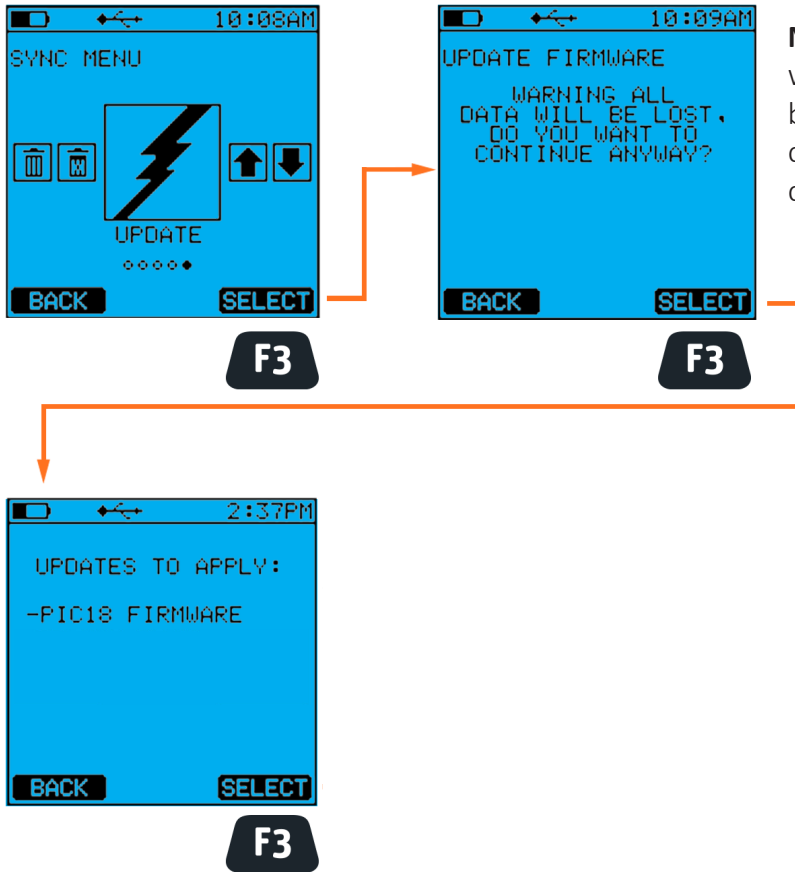

UPDATING THE FIRMWARE

IMPORTANT: Make sure the battery is fully charged before you update the firmware.

1. Copy the firmware image, FIRM_1.MT1, to the top level of a formatted USB drive that contains no other files.
2. Insert the USB drive into the CADD USB A slot.
3. Turn on the power to the CADD.
4. Press the right arrow key once to choose Data Manager. Press F3 to choose Select.
5. Press the left arrow key to choose UPDATE. Press F3 to choose Select.
6. Press F3 to acknowledge the warning that appears.
7. Make sure PIC18 Firmware is listed for update, and then press F3 to choose Select.
8. Wait about 13 seconds for the update to complete. Power to the tester automatically turns off when the update is complete.
9. Remove the USB drive.



Franklin Electric
GRID SOLUTIONS

167-000450 r7