

**DETAIL OF EARTH GROUNDING**

Grounding hardware to be #8 or larger & S.S.

\*Lockwashers to be internal or external tooth type

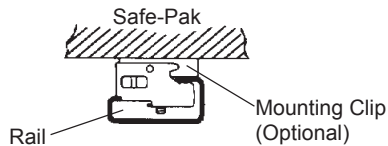

**FIG. 3 Details of Safe-Pak Grounding**

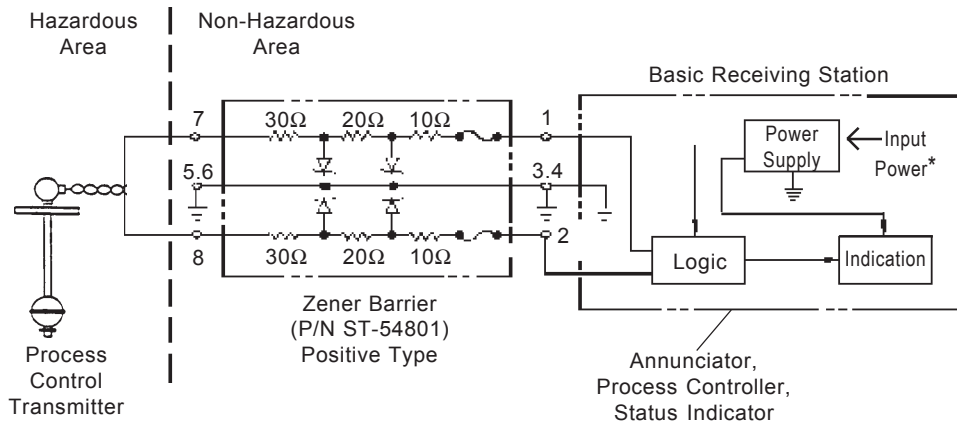

\*From a source not greater than 250 VAC

**- FIG. 4: Intrinsically Safe Loop Schematic -**

GEMS 54800 Series SAFE-PAK is a solid-state, energy-limiting device for transmitting direct current signals of less than 15V and less than 200 mA in an intrinsically safe manner. The unit is designed to be used in conjunction with indicating equipment in hazardous areas defined as Class 1, Division 1, Group D. The ambient temperature operating range of this device is 0° to 60° C (+32° to +140°F).

**\*\*\* Warning:** To prevent ignition of flammable or combustible atmospheres, disconnect power before servicing.

The instructions in this bulletin cover GEMS Zener Barrier SAFE-PAKS P/N ST-54801, for use where circuit common is earth-ground-referenced and P/N ST-54802, for use where circuit source voltage (V+) is earth-ground-referenced.

1. Only one sensor and one receiving station per channel may be connected to a barrier. **(See Figure 1)** The nature of the sensor must be that it is a non-voltage-producing, resistive termination, containing no energy-storing devices.
2. The barrier and receiving station must be located in a non-hazardous location.
3. The mounting bracket on the barrier must be connected to an earth ground from both mounting points and two lines for redundancy. The grounding should be adequate for conduction of line generated fault currents. The impedance of either line to earth should be maintained at less than one ohm
4. To serve multiple tank installations, additional barriers may be placed in an enclosure using a common earthing ground. **(See Figure 2)** In this enclosure, the intrinsically safe wiring should be segregated from non-intrinsically safe wiring by independent raceways, wiring trays or other adequate means to insure the integrity of the installation. Minimum field wiring insulation thickness to be not less than .010".

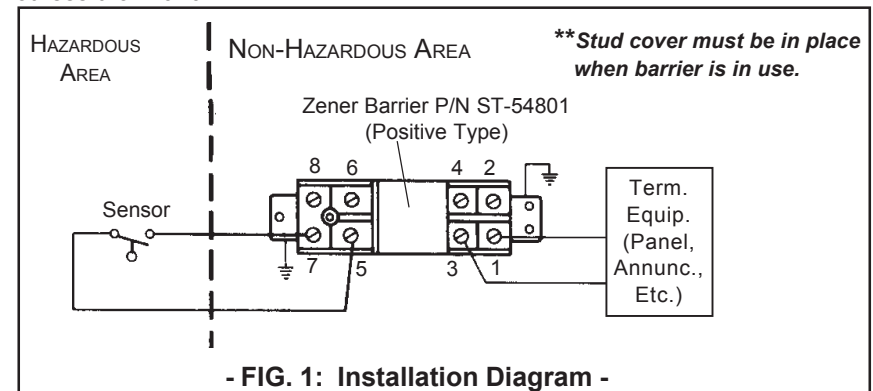

**- FIG. 1: Installation Diagram -**

5. Hazardous area field wiring will store energy due to distributed capacitance and inductance in proportion to its length. It is therefore recommended that the characteristics (available from the manufacturer) of the cable be known and judged against the length of run and atmosphere of exposure. The following chart is presented as a guideline in determining the limits of reactance for signal loops in the hazardous area wiring for this barrier.

Group	Media	Capacitance	Inductance
D	Propane	5.6pf	0.7mh

**Example:** Typical values of capacitance for a twisted pair of copper wires is between 20 and 60 pf per foot. Using the maximum value of 60 pf/Ft., inductance of a typical twisted pair is between 0.10 and 0.20 mh/Ft. The maximum values of capacitance/or inductance should be used to determine field wiring length.

## 6. Field Testing of Barrier

- A. Never conduct tests while circuit is active. The use of instruments between input and output terminals will bypass barrier.
- B. All testing is to be done with circuit inactive using the following instruments:
- Ohmmeter with resolution down to less than 1 ohm
  - D. C. power supply with an output of 0 to +20 VDC
  - D. C. voltmeter

### C. Test performance (See Figure 4).

#### Step 1

Disconnect all leads to unit under test except earthing/mounting tabs.

#### Step 2

- a. Measure the resistance between terminals 1 & 7 and then 2 & 8. This resistance should be 60 ohms  $\pm 5\%$  ( $\pm$ instrument tolerance).
- b. Measure the resistance between terminals 5 & 3 and then terminal 5 and the bracket. Both readings should be below one ohm.
- c. Apply 20 volts to terminals 7 (+) and 5 (common). Then read the voltage between terminals 1 (+) and 3 (common). This voltage must be between 14.2 and 15.7 volts. In the same fashion, conduct this same test with the voltage impressed across 8 (+) and 6 (common) and measure the output across 2 (+) and 4 (common).
- d. Connect an ohmmeter between the mounting bracket (not the mounting screw) and the earth ground reference. The reading must be less than one ohm. **The barrier must pass all parts of this test or it is unacceptable.**

## 6. Field Testing of Barrier

Step 2.d. (Cont.)

**Note:** The fuses located in the legs 7-1 and 8-2 are rated at 200 ma. Therefore, care should be exercised in testing this device so that no accidental current greater than 200 ma enters or leaves pins 1 or 2.

7. Every effort should be made to keep these barriers clean and free of contaminating atmospheres. A periodic check should be made to verify that they are in good condition, both physically and electrically.
8. Each sensor must have its own ground return wire to pins 5 and 6.

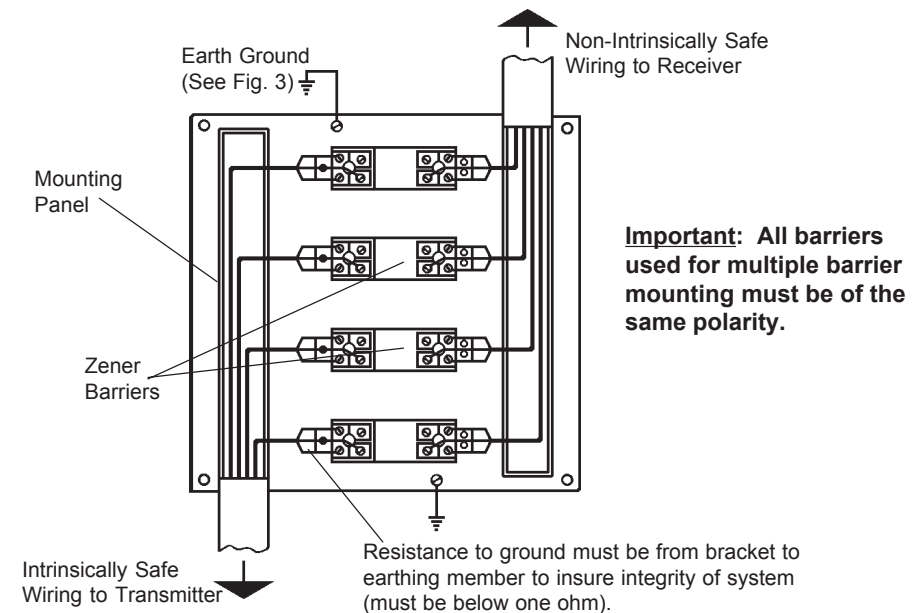

**FIG. 2 Multiple Barrier Mounting**