



CAP-300 Series Reliable Coolant Level Sensor

General Description

The CAP-300 capacitive level sensor is one of our most durable and reliable point level sensors. Compatible with aqueous based coolants, the CAP-300 is the ideal OEM solution for power generation equipment, off-highway vehicles and cell phone tower generators. With nearly zero maintenance, the sensor is small in size, tolerates moderate coating buildup and will remain reliable even in the standby mode. Capable of temperatures up to 257°F (125°C) the CAP-300 is the ideal solution for the most challenging product environments.

Principle of Operation

1. Function

- a. The sensor's protruding black electrode detects the presence or absence of the liquid medium and actuates a solid state switched output.

The sensor is optimized to detect any concentration of glycol based coolant commonly used in internal combustion engines.

2. Orientation and Mounting

- a. The sensor may be mounted in any position.
- b. Mating customer surfaces should be kept a minimum of 0.1" from any surface of the black plastic electrode.

Specifications:

Mountings	1/4"NPT, 1/2"-20 per SAE J1926-3, M12x1, M12x1.5 ISO 6149-3
Housing Material	Brass
O-ring Material	EPDM
Electrode Material	Versaplast™
Operating Pressure	0-100 psig
Operating Temperature	Deutsch®/Leads -40°F to +257°F (-40°C to +125°C) Cable Versions -4°F to +158°F (-20°C to +70°C)
Supply Voltage	9 to 32 VDC
Current Consumption	15mA max. (no load)
Output	Open collector, sinking or sourcing output, 9-32 VDC, 30mA max.
Response time to fluid	Less than 1 second
Electrical Termination	3-pin Deutsch® (DT04-3P), 18 AWG Type SXL flying leads 12" std. (304.8mm) or 18 AWG PVC Cable 3' std.
Sensing Element Length	1.03"(26.16mm) (including thread length)
Approvals	CE, RoHS

Installation:

1. Tighten sensor to the applicable torque shown in table. Do not apply torque to the plastic components.
2. 1/2"NPT Sensors: Apply a curing type thread sealant (such as Loctite #565 with primer "N"), which is compatible with the liquid media. We do not recommend pipe tape. Torque one to two turns (maximum) past the hand-tight engagement. Over torque of the sensor can permanently damage sensor.

		"A" Dim. Ref.	EPDM O-Ring	Torque
Thread	1/2"-20	0.43" (10.9 mm)	3-905	18/20 ft lbs
	M12x1-8g	0.53" (13.5 mm)	2-110	11/13 ft lbs
Sizes	M12x1.5	0.6" (15.2 mm)	9.3x2.2 mm	18/20 ft lbs
	1/4"-18NPT	0.62" (15.7 mm)	None	See Note 2

Wiring Diagrams:

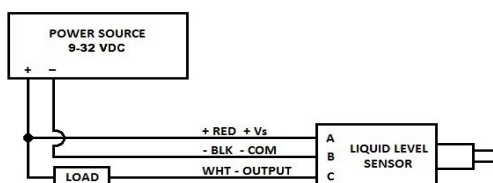

Sinking

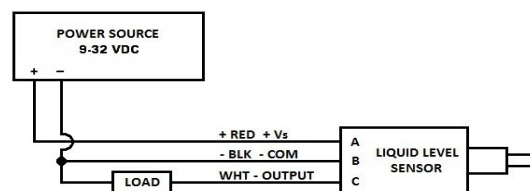

Sourcing

Dimensions:

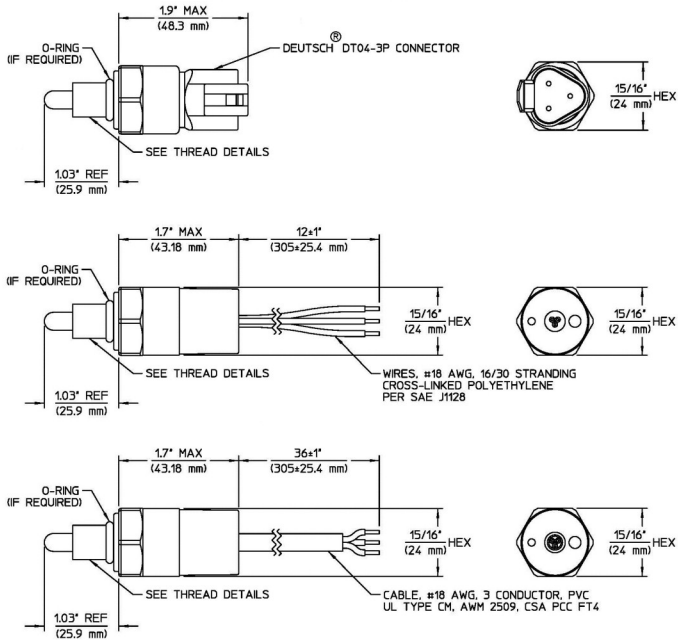

Thread Details:

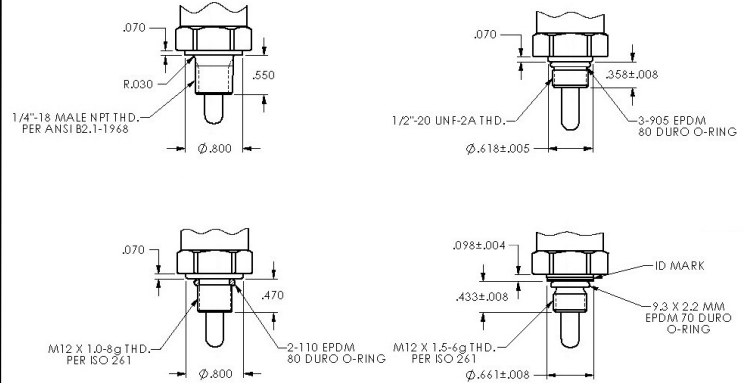

Important Points:

- Gems products must be maintained and installed in strict accordance with the National Electrical Code and the applicable Gems product instruction Bulletin that covers installation, operation, and proper maintenance. Failure to observe this information may result in serious injury or damages.
- For hazardous area applications involving such things as, but not limited to, ignitable mixtures, combustible dust, and flammable materials, use an appropriate explosion proof enclosure or intrinsically safe interface device.
- Please adhere to the pressure and temperature limitations shown throughout this catalog for our level and flow sensors. These limitations must not be exceeded. These pressures and temperatures take into consideration possible system surge pressures/temperatures and their frequencies.
- Selection of materials for compatibility with the media is critical to the life and operation of Gems products. Take care in the proper selection of materials of construction; Testing is required.
- Our sensors have been designed to resist shock and vibration. However, shock and vibration should be minimized.
- Electrical entries and mounting points in an enclosed tank may require liquid/vapor sealing.
- Our sensors must not be field-repaired.
- Physical damage sustained by product may render it unserviceable.

Return Policy

Returns are accepted on stock items up to 30 days from date of order. You must contact our Returns Department for a Return Authorization (RA) number. Return the goods—freight prepaid—in the original container and include original packing slip. COD returns are not accepted. Gems reserves the right to apply restocking charges.