



Piston-Type Flow Switches

Series FS-925/926 & FS-927/930

Instruction Bulletin No. 72949

Important Points!

Product must be maintained and installed in strict accordance with the National Electrical Code and Gems product catalog and instruction bulletin. Failure to observe this warning could result in serious injuries or damages.

An appropriate explosion-proof enclosure or intrinsically safe interface device must be used for hazardous area applications involving such things as (*but not limited to*) ignitable mixtures, combustible dust and flammable materials.

*** Warning: To prevent ignition of flammable or combustible atmospheres, disconnect power before servicing.

Pressure and temperature limitations shown on individual catalog pages and drawings for the specified flow switches must not be exceeded. These pressures and temperatures take into consideration possible system surge pressures/temperatures and their frequencies.

Selection of materials for compatibility with the media is critical to the life and operation of GEMS flow switches. Take care in the proper selection of materials of construction; particularly wetted materials.

Life expectancy of switch contacts varies with applications. Contact GEMS if life cycle testing is required.

Ambient temperature changes do affect switch set points, since the specific gravity of a liquid can vary with temperature.

Flow switches have been designed to resist shock and vibration; however, shock and vibration should be minimized.

Liquid media containing particulate and/or debris should be filtered to ensure proper operation of GEMS products.

Electrical entries and mounting points may require liquid/vapor sealing if located in an enclosed tank.

Flow switches must not be field repaired.

Physical damage sustained by the product may render it unserviceable.

Installation . . .

Unless otherwise specified at time of purchase, units are calibrated in a vertical position, with lead wires up. Install unit in piping system, using standard pipe fitting procedures. Hold inlet fitting with wrench at installation to prevent fitting torque accumulation. Be sure to keep thread sealing compound out of unit. Make sure that flow is in proper direction - marked "IN" and "OUT" on housing. See wiring diagrams for electrical connections.

CAUTION: See "Switch Ratings" before connecting power.

CAUTION: Flow settings for **FS-920** series switches are normally calibrated using water** @ +70°F on increasing flow. If unit will be used to monitor liquids other than water, gas or air, Factory should have been consulted at time of purchase for special calibration. All air/gas units are factory-calibrated using a special piston. Water-calibrated units are not recommended for air/gas applications.

****Note:** Flow settings for **FS-930** Viscosity Compensating type switches are calibrated in a vertical position (lead wires up) with 300 SSU oil. Set points will be maintained within 20% of settings in a liquid viscosity range of 40 to 2,000 SSU.

Specifications . . .

	FS-925/FS-926	FS-930	FS-927
Wetted Materials			
Housing	Brass or 316 SS	Brass	Brass
Piston		Brass	Brass
Brass Housing	Polysulfone/Water - Brass/Oil or Air		N/A
Stainless Steel Housing	316 SS		N/A
Spring	316 SS		
O-Ring	Viton®		N/A
Other Wetted Parts	Epoxy		SS
Pressure Rating			
Operating	1000 PSIG		1000 PSIG, Max.
Proof	2500 PSIG		
Burst	5000 PSIG		
Operating Temperature			
Brass or SS Piston	-20°F to +300°F	-20°F to +300°F	-20°F to +200°F
Polysulfone Piston	-20°F to +225°F		N/A
Repeatability	1% Maximum Deviation	15%, Max.	N/A
Set Point Accuracy	±10%		±15%
Set Point Differential	15% Max.(FS-925) - 20% (FS-926)		20% Max.
Switch*	SPDT, 20 VA		SPST, 20 VA
Inlet/Outlet Ports	1/4" NPT		1/4" NPT
Electrical Termination	No. 18 AWG, 24" L., Polymeric Lead Wires		No. 18 AWG, 24" L., PVC Lead Wires



Gems Sensors Inc.
One Cowles Road
Plainville, CT
06062.1198

tel 860.747.3000
fax 860.747.4244

Dimensions . . .

FS-925/926/930 Series

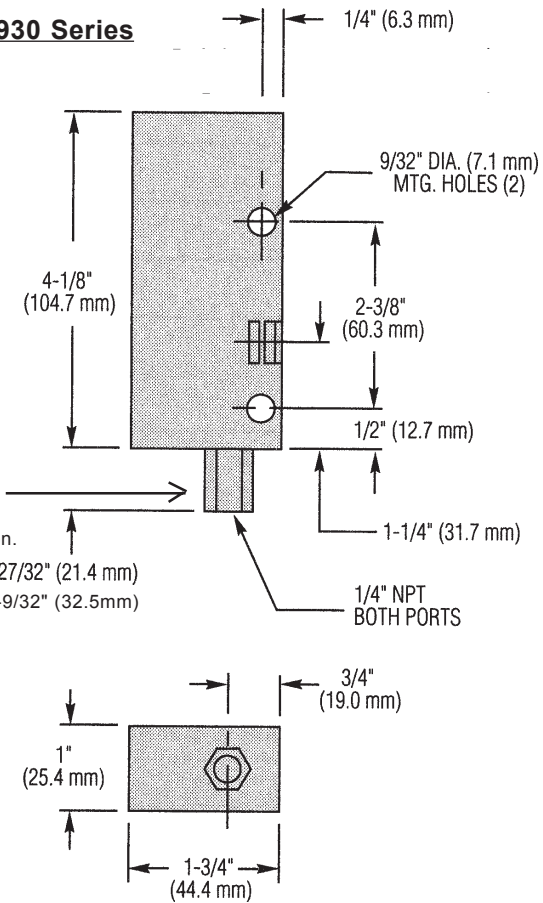

For FS-926 the inlet fitting is torqued at the factory. Hold fitting hex with wrench at installation to prevent additional accumulation torque which could cause sensor malfunction.

(FS-925/FS-930) 27/32" (21.4 mm)
(FS-926) 1-9/32" (32.5 mm)

FS-927 Series

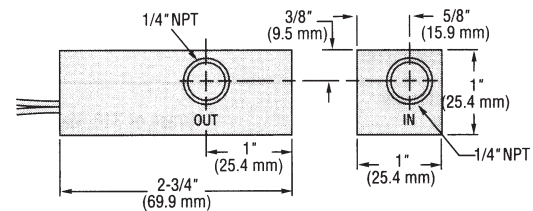

**Electrical Connection
(1/2" NPT Conduit)**

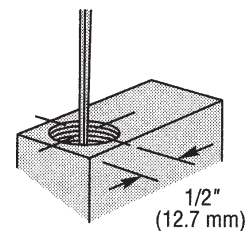

Maintenance . . .

Accumulation of foreign debris should periodically be removed from these switches. Occasional "wipe-down" cleaning when excessive contamination is present is all that is normally required. To clean: Remove unit from system and disassemble as shown below. Clean all parts, reassemble and reinstall unit.

Note: 50 micron filtration is recommended.

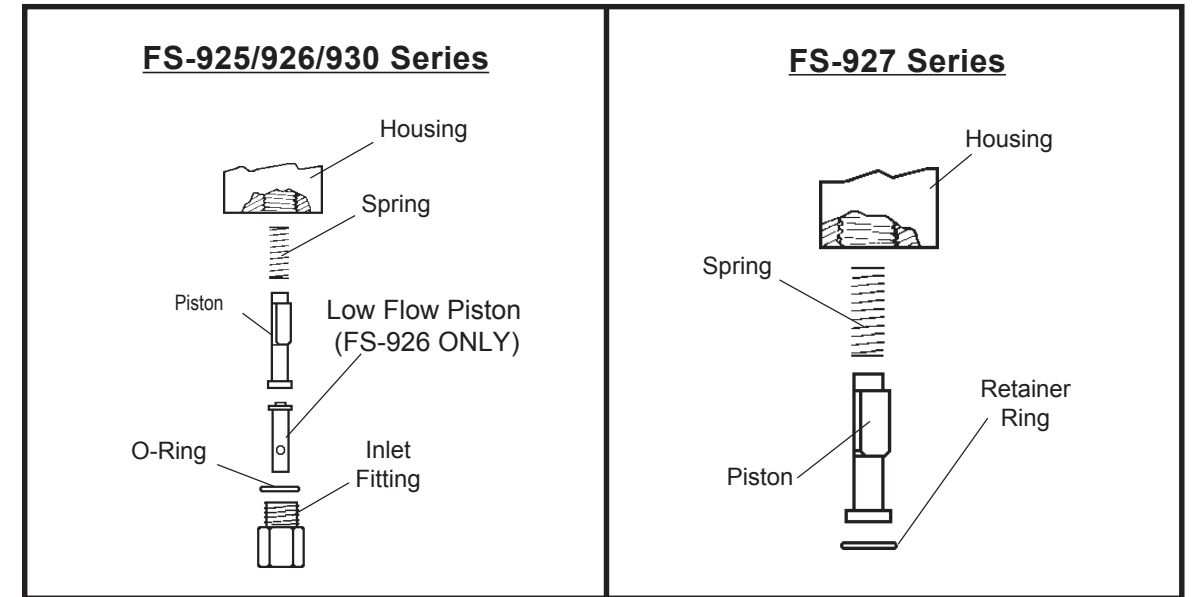

Typical Wiring Diagrams

FS-925, FS-926, FS-930 Series

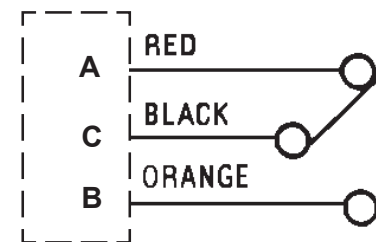

Pin Connections for Units with MS Receptacle

FS-927 Series

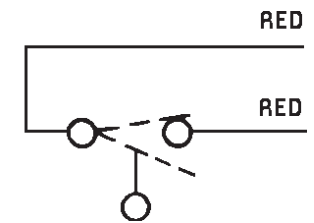

**Switch Ratings
Max. Resistive Load**

VA	Volts	Amps AC	Amps DC
20	0-30	.4	.3
	120	.17	.13
	240	.08	.06



This product is suitable for Class I and Class II applications only, per the requirements of standard EN60730 and any additional specific requirements for a particular application or medium being sensed. Class I compliance of metal bodied units requires a ground connection between the metal body and the earthing system of the installation. Class I compliance of plastic bodied units in contact with a conductive medium requires that the medium be effectively earthed so as to provide an earthed barrier between the unit and accessible areas. For Class III compliance, a supply at safety extra-low voltage (SELV) must be provided. Please consult the Factory for compliance information on specific part numbers.