



Motic®

MORE THAN MICROSCOPY



GM-161/GM-171

**Motic New Generation
Gemology Microscope**



GM-161/GM-171

Motic New Generation Gemology Microscope

The GM-161 / 171 utilizes the optical performance of Motic's SMZ-171 stereomicroscope to enhance distinct three-dimensional details with a zoom function. Rugged and precise, the optics of the GM-171 performs indentifications, analyses, and measurements more accurately and efficiently, thus reducing your workload. At a working distance of 110mm, manipulation of the inspected gem or the addition of a further apparatus is permitted without obstruction.

Available in a trinocular version for photographic or digital capture of the gem, the GM-161 / 171 provides you with an opportunity for extra revenue. Moreover, when teamed with Motic's new generation Moticompro series, the GM-161 / 171 becomes your instrument of instruction for teaching and training by showcasing the gem in real time via a television, a projector, and computer simultaneously.







GM-161

Optics

GM-161

- Multi-coated lens
- Relax View accessible
- Magnification range: 0.75X-4.5X
- Zoom ratio: 1:6
- Observation angle: 45°
- Working distance: 110mm
- Interpupillary Distance: 50mm-75mm

Eyepieces

- N-WF10X (ø20) eyepiece, 10X (ø23) for optional, with eyepiece tube adjustable
- Field of view range: 30.67mm - 1.33mm
- Mount diameter: ø30mm
- Reticules: ø25mm

GM-171

- Multi-coated lens
- Relax View accessible
- Magnification range: 0.75X-5X
- Zoom ratio: 1:6.7
- Observation angle: 45°
- Working distance: 110mm
- Interpupillary Distance: 48mm-75mm
- Excellent resolution

Eyepieces

- N-WF eyepiece, high eye-point 10X(ø23), Diopter adjustable, interchangeable with biological eyepieces
- Field of view range: 30.67mm - 1.3mm
- Mount diameter: ø30mm
- Reticules: ø25mm



GM-171

Illumination

Bright field Illumination

Integrating a consistent and powerful 30W Quartz Halogen Bright field illumination with a precise, adjustable aperture diaphragm [ø41mm - ø2mm], you are able to measure with a table gauge the proportions and pavilions of a diamond.

Dark field Illumination

Dark field is the ideal illumination for observation of inclusions. With Motic's versatile aperture diaphragm [pictured above], you can control the depth of field and contrast while using the dark field illumination for better identification.

Incident fluorescent illumination - Diamond Light

Designed for use with diamonds, the incident light can be adjusted for a thorough examination of the clarity, colour, and finishing. The bulb has a colour temperature of 6000K to reduce any yellowing effects on the gem.

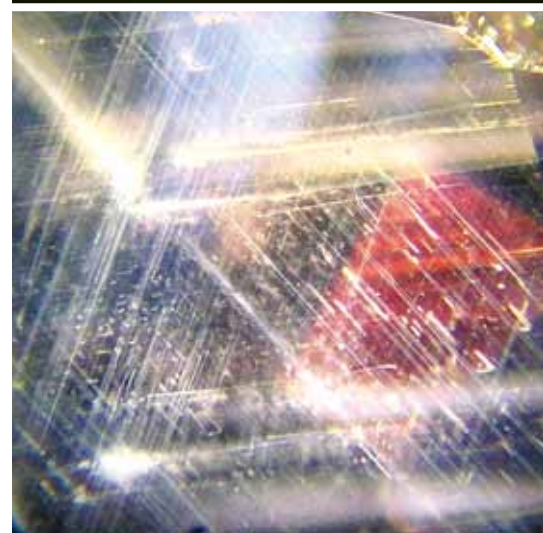
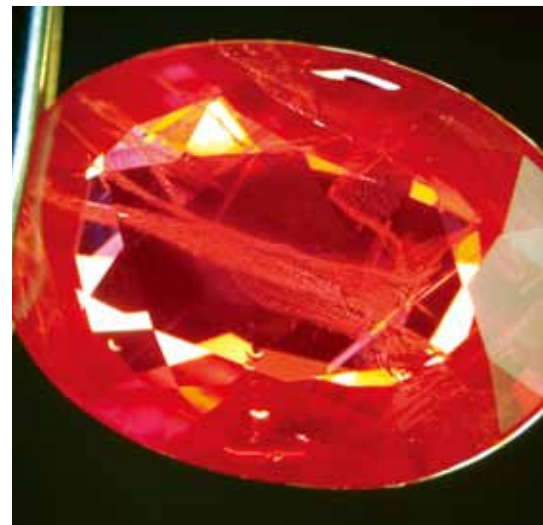
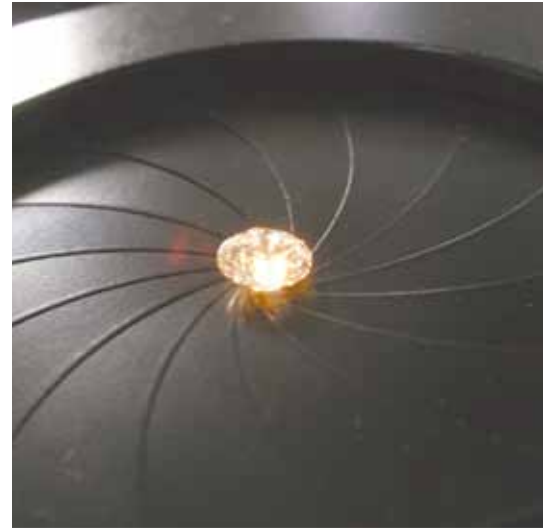



Rounded Edge Stone holder



Wire Stone holder



Inclusion pointer

Large gem stage plate

Magnetically attachable and covering the stage area of the GM168 base to provide a large surface for rough stones and large gems [i.e. Jade] inspection in conjunction with the incident fluorescent illumination.

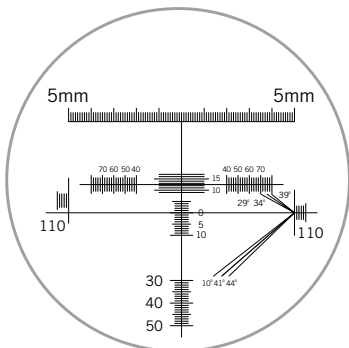

GM-161



GM-171

Holders, Plates, and Analysers

Wire Stone holder

The ideal holder for diamonds, rubies and sapphires. Comprised of stainless steel for a long working life, the wire stone holder permits the maximum amount of observation.

Rounded Edge Stone holder

Perfect for irregular gems and jewellery. Precision crafted of stainless steel to provide an adequate grip without corrupting irregular shaped gem samples.

Inclusion pointer

For rapid location of inclusions and fractures on the surface of gem.

Diamond Proportion Analyser Kit

Complete kit for effective and accurate identification and measurement of proportions and pavilions. Includes the magnetised diamond mount, diamond proportion reticule, and micrometer eyepiece [10x].



Immersion cell

Capable of rapid and easy detection of treated gems characteristics; such as clarity enhancement, HPHT annealing, irradiation, and surface colouration, the immersion cell is especially useful for rubies.



Contrasts

Polariser Kit

Perfect for observing the bireference of crystals and the quality of the finish on certain stones. Mounts conveniently on the zoom body and stage.



Diffuser Plate

Eliminates excessive bright spots for true inclusion identification. Magnetically mountable on the stage.

Auxiliary Objectives

Additional magnification with the truest optical clarity and large field of view.

1.5x auxiliary objective	2.0x auxiliary objective
56.3 mm working distance	38.6 mm working distance
GM-161: 67.5x maximum magnification*	GM-161: 90x maximum magnification*
GM-171: 75x maximum magnification*	GM-171: 100x maximum magnification*

*With standard N-WF10x eyepieces.

Auxiliary Eyepieces

Convenient additional magnification without the loss of working distance.

15x eyepieces	20x eyepieces
GM-161: 67.5x maximum magnification*	GM-161: 90x maximum magnification*
GM-171: 75x maximum magnification*	GM-171: 100x maximum magnification*
GM-161: 3.56mm minimum field of view *	GM-161: 2.89mm minimum field of view *
GM-171: 3.2mm minimum field of view *	GM-171: 2.6mm minimum field of view *

*With standard 1.0x objective.



Stand Features and Benefits

Rotary Base

360° rotary base allows you to showcase the gem to a customer or to confer with a colleague on proper identification.



Tilting base

With a tilting range of 0° [upright] to 45°, the GM-168's base is accessible to users of various heights.



Focus Adjustment

Allowing for a total travel of 125mm for adaptation to different sizes of gems and stones, no sample is too small or too large.

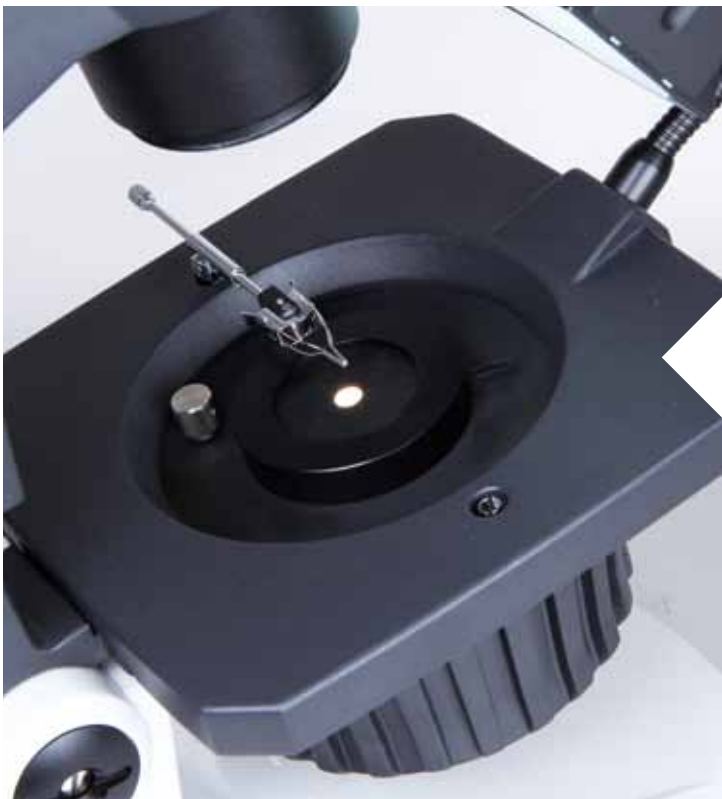

Stage

Able to accommodate both a gem holder and inclusion pointer simultaneously in addition to different contrast methods.

GM-161/ GM-171 Schematic

Schematic diagram Unit: mm

GM-161 Trinocular Gemology Microscope

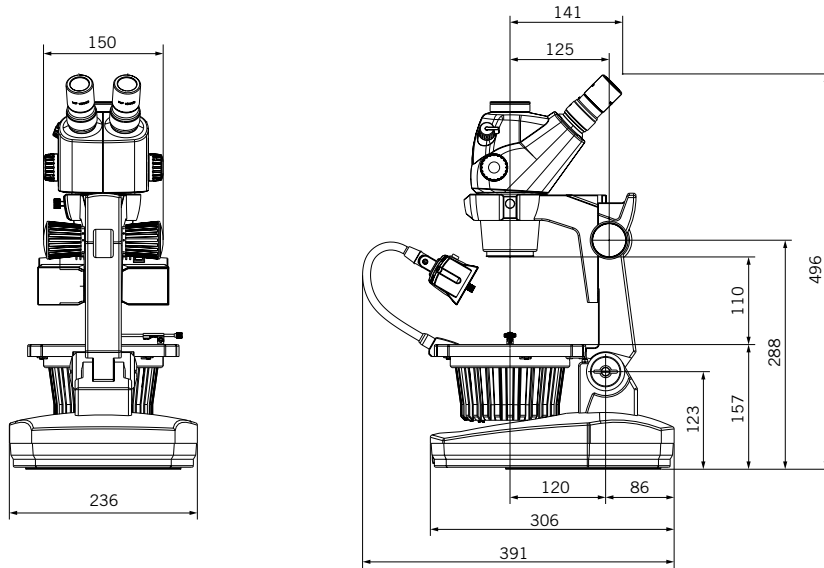

GM-171 Trinocular Gemology Microscope

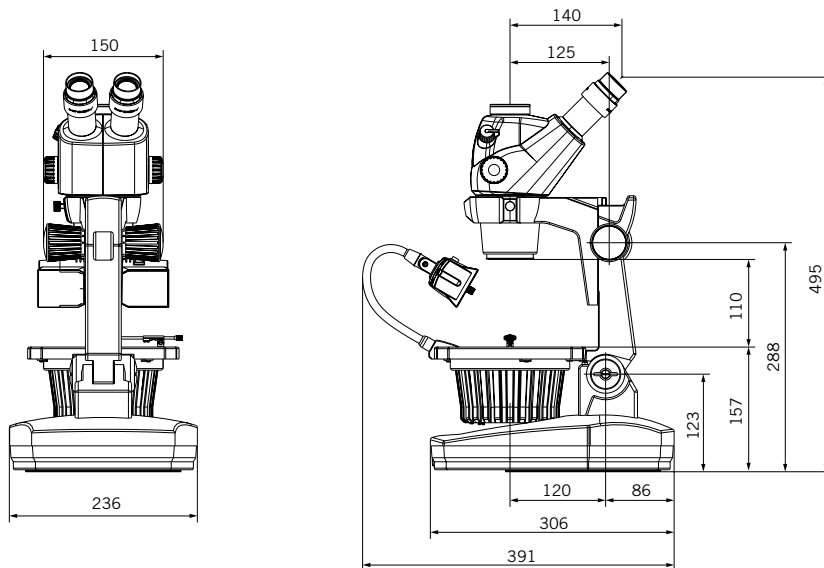

GM-161/ GM-171 Specifications

Model	GM-171B	GM-171T	GM-161B	GM-161T
Optical system	Greenough			
Observation angle	45°/ 60°	45°	45°/ 60°	45°
Magnification range (standard)	0.75X--5X		0.75X--4.5X	
Zoom ratio	1:6.7		1:6	
Eyepiece	N-WF, high eye-point 10X(Ø23), Diopter adjustable interchangeable with biological eyepieces N-WF 12.5X(Ø18), 15X(Ø16), 20X(Ø13) optional		WF10X (Ø20) / eyepiece tube adjustable N-WF 10X (Ø23), N-WF 15X (Ø16), 20X (Ø13) optional	
Interpupillary adjustment	48mm-75mm		50mm-75mm	
Working distance (standard)	110mm		110mm	
C-Mount adapter	/	0.5X, 0.65X, 1X adapters available	/	0.5X, 0.65X, 1X adapters available
Photo adapter	/	Photo adapter 2.5X, 4X photo eyepiece available"	/	Photo adapter 2.5X, 4X photo eyepiece available"
Auxiliary ESD objectives	1.5X [WD = 56.3mm], 2.0X [WD = 38.6mm]			
Stand option	Incident illumination	7W fluorescent light, colour temperature of 6000K to reduce any yellowing effects on the gem, angle adjustable		
	Transmitted illumination	6V/30W Halogen		
	Focusing adjustment	125mm		
	Stage	Mounting hole for gem holder on both sides Users can choose the position freely		
	Tilting base	With a tilting range of 0°(upright) to 45°, accessible to users of various heights		



Canada | China | Germany | Spain | USA

Motic®

www.motic.com

Motic Instruments Inc. (CANADA)

130 - 4611 Viking Way, Richmond, BC V6V 2K9 Canada
Tel: 1-877-977 4717 Fax: 1-604-303 9043

Motic Deutschland GmbH (GERMANY)

Christian-Kremp-Strasse 11, D-35578 Wetzlar, Germany
Tel: 49-6441-210 010 Fax: 49-6441-210 0122

Motic Incorporation Ltd. (HONG KONG)

Rm 2907-8, Windsor House, 311 Gloucester Road,
Causeway Bay, Hong Kong
Tel: 852-2837 0888 Fax: 852-2882 2792

Motic Spain, S.L. (SPAIN)

Poligon Industrial Les Corts, Camí del Mig, 112
08349 Cabrera de Mar, Barcelona, Spain
Tel: 34-93-756 6286 Fax: 34-93-756 6287

* **CCIS®** is a trademark of Motic Incorporation Ltd.

**Motic Incorporation Limited Copyright © 2002-2009
All Rights Reserved.**

Design Change :

The manufacturer reserves the right to make changes in instrument design in accordance with scientific and mechanical progress, without notice and without obligation.



Updated: 25.10.2012
Code: 1300901304291