

Step 7

Carefully, rotate the shelf assembly (from Step 5), upside down as shown.

Place the base tube assembly (from Step 6) onto the vertical legs of the shelf assembly.

Attach the base tube to each leg using a total of three 3-1/2" Bolts (325-5000-00). Tighten all screws and bolts.

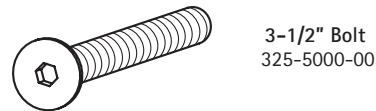

3-1/2" Bolt
325-5000-00

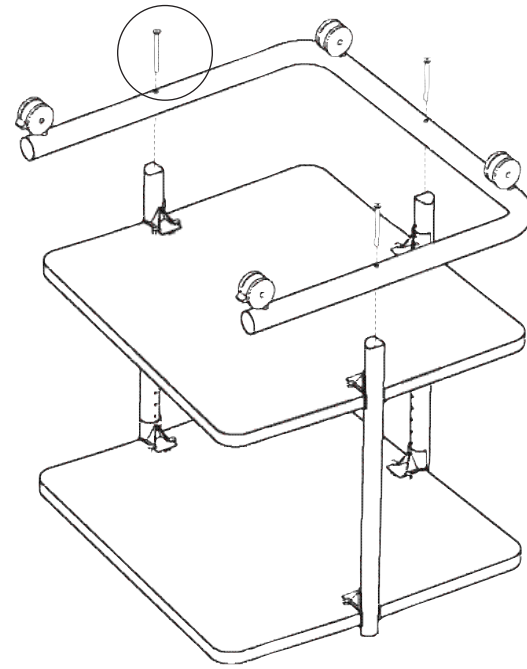

Step 8

Rotate your cart over onto the casters.

Pop the 1.5" small end caps into the vertical legs and the 1.75" large end caps into the base tube.

After you add your equipment to the cart, select the cable management components that suit.

To install the Cable Alleys, expand each sleeve and fit it over a cart leg. Align the mounting hole(s) in the sleeve with the holes on the leg, then install with self-threading screws.

To install the Cord Handler, snap the large end around any cart leg, then route cables through the small end.

Congratulations! Your assembly is complete.

Please return the enclosed Registration Card to receive our product updates, new catalogs, and sale flyers.

Thank you for choosing Anthro!

1.5" Small End Cap

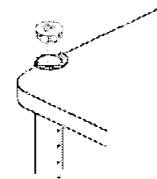

1.75" Large End Cap

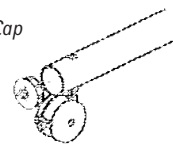

24" Wide AnthroCart Assembly Instructions



These Assembly Instructions are for the GT03xx.

Before beginning assembly of your 24" wide AnthroCart, please take a moment to review the parts list below to verify that your shipment is complete.

Does your Cart have 4" Casters?*
(Such as a GT03xx4. Your Caster Part Numbers are given here.)

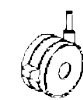

4" Locking Caster
150-5011-00



4" Non-Locking Caster
150-5010-00

TOOLS

To make the assembly of your cart even easier, we have included all of the required tools. Use the handy Hex Driver Bit in your electric drill in place of the Hex Driver.

Hex Driver 5/32"..... 375-5000-00
Hex Driver Bit 5/32"..... 375-5003-00
8 oz. Rubber Mallet..... 375-5022-00

Enclosed Parts List

Detailed views of all Hardware is provided with each Assembly Step.

01- Vertical Legs	Qty. 3	125-5020-xx
02- Insert Screws	Qty. 4	325-5052-00
03- 1.75" Large End Caps.....	Qty. 2	175-5021-xx
04- Caster Inserts	Qty. 4	525-1000-00*
05- 2 3/8" Locking Casters.....	Qty. 2	150-5003-00*
06- 3-1/2" Bolt.....	Qty. 3	325-5000-00
07- 2 3/8" Non-Locking Casters	Qty. 2	150-5002-00*
08- 24" Wide Base Tube.....	Qty. 1	125-5005-xx
09- 1-5/8" Screw	Qty. 6	325-5086-00
10- Shelf Support.....	Qty. 6	175-5060-xx
11- Shelf Clamp.....	Qty. 6	175-5059-xx

12- 24" Wide Small Shelf.....	Qty. 1	100-6006-xx
13- 1.5" Small End Caps.....	Qty. 3	175-5020-xx
14- 24" Wide Large Shelf	Qty. 1	100-6004-xx
15- Self-threading Screws	Qty. 6	325-5010-00

All fastener quantities listed here are the minimum needed for your cart assembly. Your shipment may include a few extras.

Cable Management Components

Cable Alley, 9"	Qty 1	175-5061-03
Cable Alley, 3"	Qty 1	175-5062-03
Cord Handler.....	Qty 1	175-5001-03
Self-threading Screws.....	Qty 6	325-5010-00

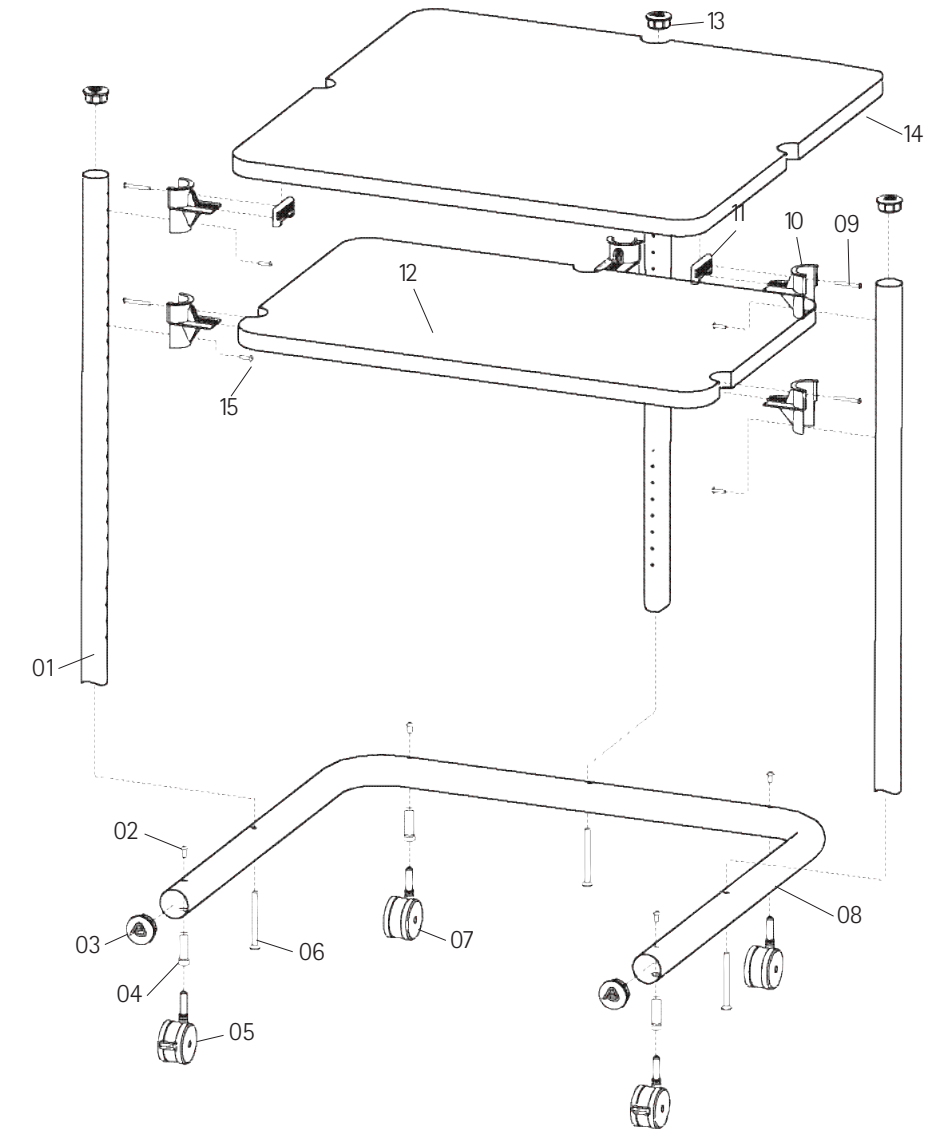

Questions?

1-800-325-3841

Anthro Corporation Technology Furniture® 10450 SW Manhasset Drive Tualatin, Oregon 97062

Rev A, January 2015

SAVE THESE INSTRUCTIONS!

anthro.com

24" Wide AnthroCart

Assembly Instructions

Questions? 1-800-325-3841

Step 1

Before proceeding, please review the Assembly Instructions of all Anthro products you purchased and are planning to include in this installation.

Decide on the shelf configuration that works best for you. Generally, customers place the large shelf at the top of the legs and the small shelf at the bottom of the legs, and that's how these instructions are organized. This configuration leaves 18" clearance between the shelves.

Shelves can be installed at any height (in 1" increments), so find the best configuration for you. If you need help configuring your cart, just give us a call!

Step 2

Attach three shelf supports to each shelf. Begin by first installing a shelf clamp into the shelf notch. Be sure the pointed barbs face towards the outer shelf edge.

Next, slide a shelf support into the recesses of the shelf clamp and shelf. Push in as far as possible.

Finally, secure with a 1-5/8" Clamp Screw (325-5086-00).

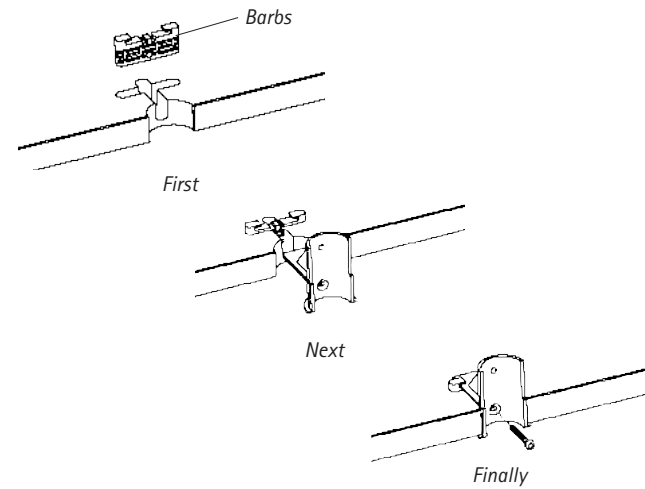

1-5/8" Screw
325-5086-00

Step 3

Loosely attach the large shelf to hole 2 from the top of one vertical leg using one Self-threading Screw (325-5010-00). These fasteners are cutting threads into the leg, so the first few turns will require some force.

NOTE: This will place your large shelf 28" from the floor using the standard 2 3/8" casters.

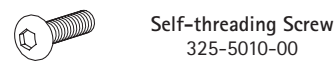

Self-threading Screw
325-5010-00

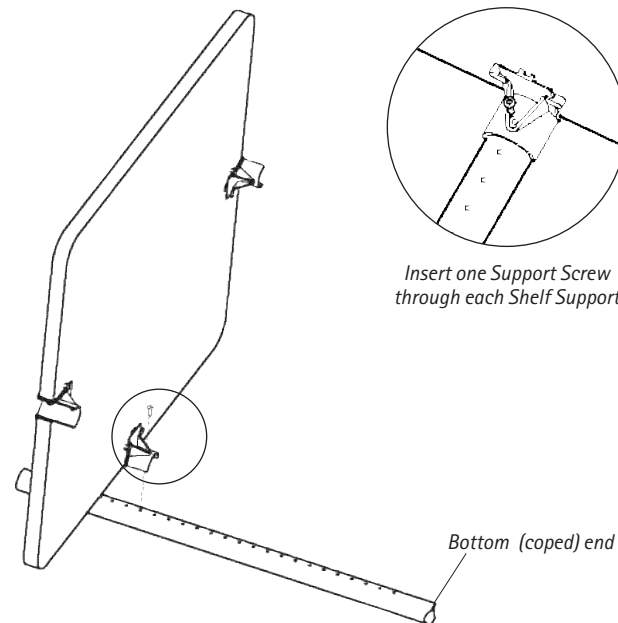

Step 4

Loosely attach the small shelf to the bottom hole on the vertical leg assembly (from Step 3) using one Self-threading Screw (325-5010-00).

NOTE: Handle the shelf assembly carefully until the Cart is fully assembled.

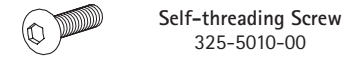

Self-threading Screw
325-5010-00

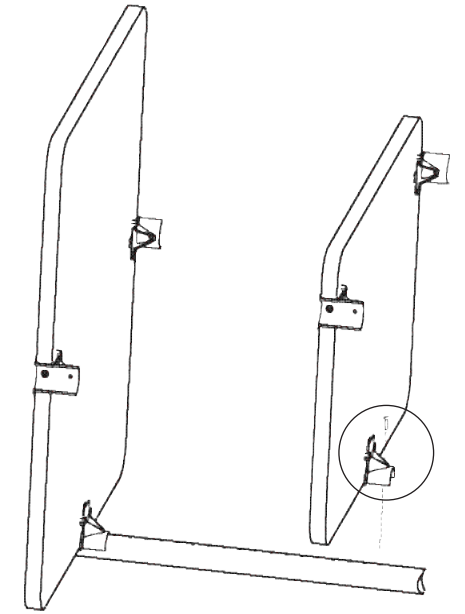

Step 5

Loosely attach the 2nd and 3rd vertical legs to the shelf assembly (from Step 4) using one Self-threading Screw per shelf support.

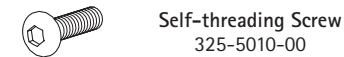

Self-threading Screw
325-5010-00

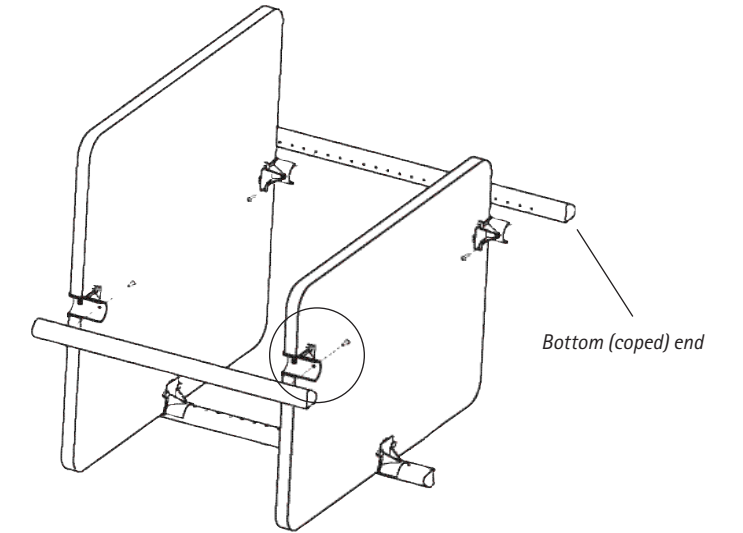

Step 6

Install all four caster inserts into the base tube and secure with one Caster Insert Screw (325-5052-00) per insert.

Push the casters, (locking ones in front) into the caster inserts. This is a friction fit and will require some effort. You may find it helpful to tap the bottom of the caster with the rubber mallet provided.

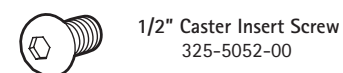

1/2" Caster Insert Screw
325-5052-00

