

Rapport Glass Wall - Classroom Series

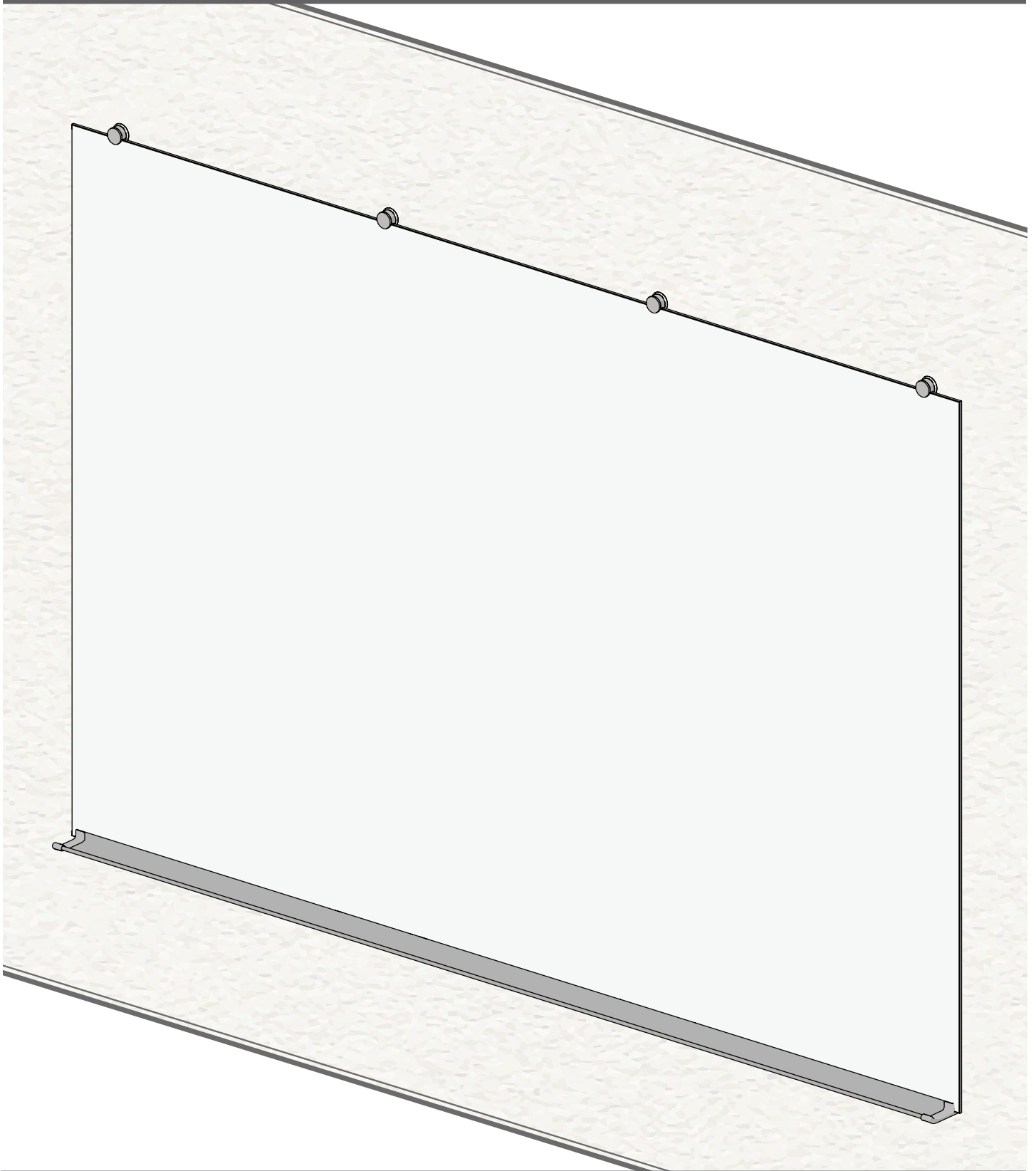

ASSEMBLY INSTRUCTIONS
DO NOT THROW AWAY!



INSTRUCCIONES DE ENSEMBLAJE
NO LA TIRE

INSTRUCTIONS DE MONTAGE
NE PAS JETER

Parts and Hardware

P1 *P Glass Board

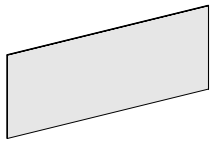

P2 x1/2 Glass Tray



Adhesive Pack

A1 *X Adhesive Pad

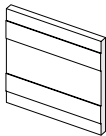

Joiner Pack

B1 *X Joiner Plate

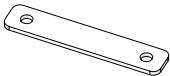

B2 x2/B1 Set Screw



Tray Pack

C1 x1 Left Tray End



C2 x1 Right Tray End

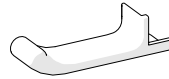

C3 x0/1 Roll Pin

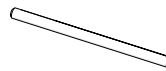

C4 x2/*P Nylon Tip Adjuster

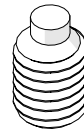

Mounting Hardware

D1 *X Wall Mount



D2 x1/D1 Outer Cap

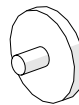

D3 *X #10 x 1 1/4" Phillips Screw

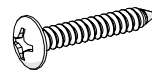

D4 *X Masonry Anchor

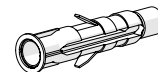

D5 *X Dry Wall Anchor

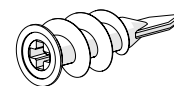

*P - # of panels per order

*X - custom # per order

This page includes only the hardware provided that may be required for this instruction. Additional hardware may be included.

WARNINGS AND DISCLAIMERS

Review full assembly instructions and check that all parts are present before beginning assembly. Heavy or large furniture may require multiple persons in order to properly assemble. If you have questions regarding assembly, contact the manufacturer before continuing. Damage due to incorrect assembly may not be covered by warranty. Do not use product unless all screws are tight. Check all screws for tightness at least every six months. If parts are broken, missing, damaged, or worn, stop use of the product until repairs are made by your dealer using factory authorized parts.

ADVERTENCIAS Y RENUNCIAS

Previo a comenzar el proceso de ensamblaje favor de revisar las instrucciones y asegurarse que cuenta con todas las partes y materiales necesarios. Es posible que los muebles grandes o pesados, requieran mas de una persona para ensamblarlos correctamente. Por favor contacte al fabricante directamente si tiene alguna duda o pregunta antes de continuar con el proceso de armado del producto. La garantía no cubrirá daños que ocurrieron por errores cometidos durante el proceso de ensamblaje. Todos los tornillos deben estar ajustados previo el uso del producto. Debe revisar los tornillos periódicamente, por lo menos cada seis meses y asegurarse de que estén bien ajustados. Por favor detenga el uso del producto si partes del producto se pierden, rompen, se deterioran por uso o se rompen. Favor de contactar a su distribuidor para que le envíen las partes necesarias o realice las reparaciones necesarias con partes autorizadas por el fabricante.

AVERTISSEMENTS

Avant de commencer l'assamblage veuillez consulter les instructions complètes et vérifier si vous avez toutes les pièces nécessaires. Il est possible que plusieurs personnes soient nécessaires pour assemble des meubles grand ou lourds. En cas de doute sur l'assamblage contactez le fabricant avant de continuer. Les dommages encourus pendant l'assamblage ne seront pas couvert par la garantie. Ne pas utiliser le produit sans vérifier que tous les vis soient serrées. Vérifiez que les vis sont serrées au moins tous le 6 mois. Si aucune pièce se casse, manque, est endommagée ou usée, arrêtez d'utiliser de produit jusqu'à ce que le vendeur le repaire a l'aide de pièces autorisées par la fabricant.

WARRANTY

For full product warranty details, please visit:

Para obtener información sobre la garantía del producto, consulte este sitio (ingles):

Pour plus d'informations sur la garantie du produit, consultez ce site (anglais):

<http://moorecoinc.com/warranty>

CARE & MAINTENANCE

For questions on assembly or missing/damaged parts, please contact us using the following information.

Para preguntas sobre el ensamblaje o piezas faltantes o dañadas, por favor contáctenos usando la siguiente información.

Pour toute question sur le montage l'assamblage manquantes ou endommagées, veuillez nous contacter en utilisant les l'information ci-dessous.

Email:

support@moorecoinc.com

Phone:

1.800.749.2258

(Monday - Friday, 8AM - 5PM

Central Time)

PRODUCT REGISTRATION

To register your product for warranty, please visit:

Para registrar la garantía del producto, vea este sitio (en ingles):

Pour enregistrer la garantie de votre produit, consultez ce site (en anglais):

<https://moorecoinc.com/register>

STEP 1A

Assembly for single piece tray. See STEP 1B for two piece tray assembly.

Insert joiners (B1) into tray bottom channel. Slide in two joiners for every panel (i.e. 4 joiners for 2 panels). Move joiners along bottom channel until one hole on every joiner is lined up with a pre-drilled hole. Be sure not to cover any pre-drilled holes by mistake.

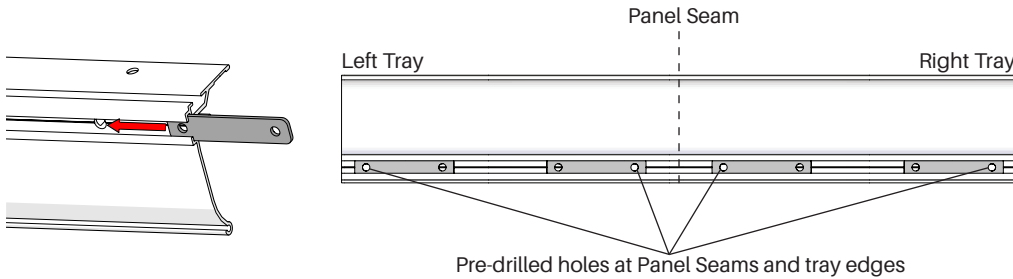
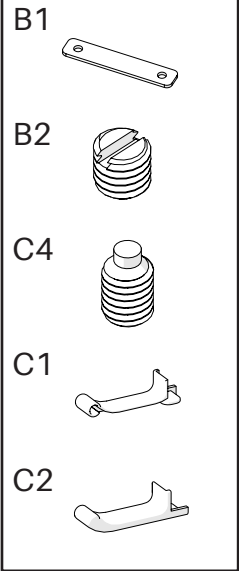

Insert set screws (B2) and adjusters (C4) through joiners. All pre-drilled holes in tray bottom will need an adjuster. Any hole in joiner not aligned with a hole in the tray should receive a set screw. See pictures below for joiner and set screw positioning.

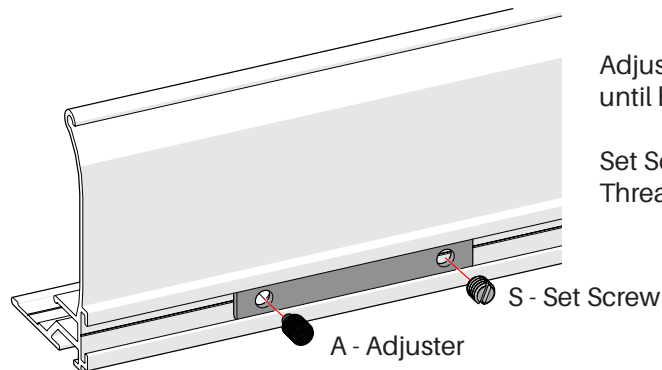

Adjusters use allen wrench. Thread until head is flush with top of channel.

Set Screws use flat-head screwdriver. Thread until hand tight.

Single Tray Single Panel:

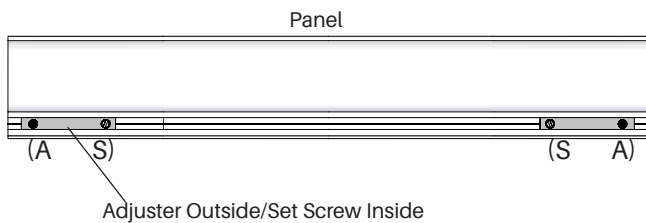

Single Tray Multi Panel:

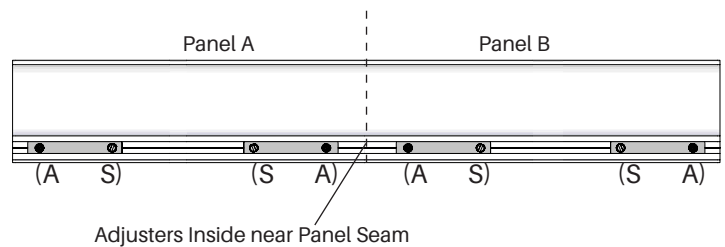

Complete tray assembly by pressing in Tray Ends (C1 and C2).

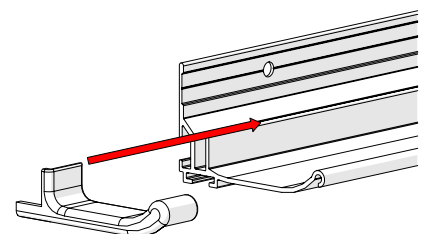

STEP 1B

Assembly for two piece glass board tray.

First splice two tray pieces together. Use one joiner (B1) on bottom channel and another on back channel with 2 set screws each (B2). These joiners should not cover any pre-drilled holes in tray. A roll pin should also be added beneath the tray's front lip.

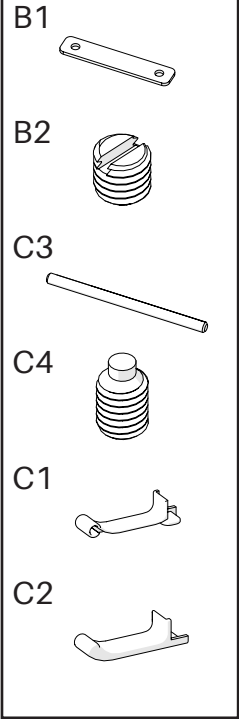
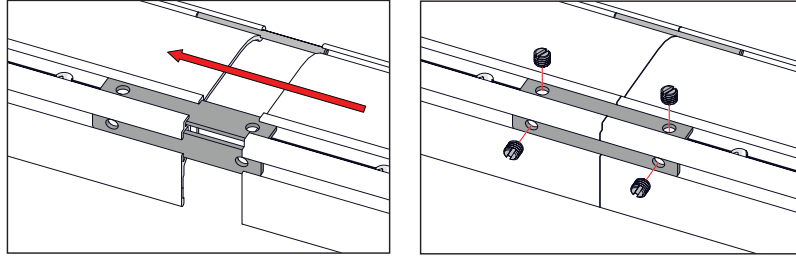

Next slide in additional joiners from ends of tray. Insert two joiners for every panel, half on each side of the splice (i.e. for 4 panels insert 4 joiners from the left and 4 from the right). Move joiners along bottom channel until one hole on every joiner is lined up with a pre-drilled hole. All pre-drilled holes in tray bottom will need an adjuster (C4). Any hole in joiner not aligned with hole in tray should receive a set screw.

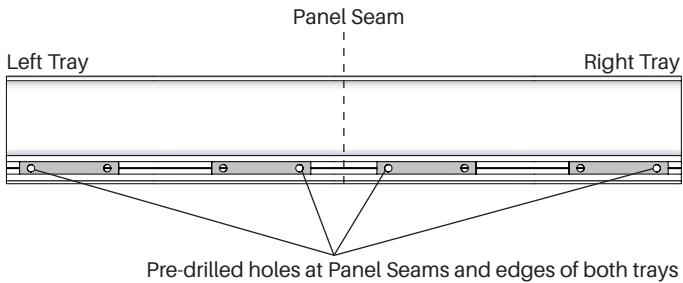

Adjusters use allen wrench. Thread until head is flush with top of channel.

Set Screws use flat-head screwdriver. Thread until hand tight.

Panel Seam at Tray Splice (Even Number of Panels)

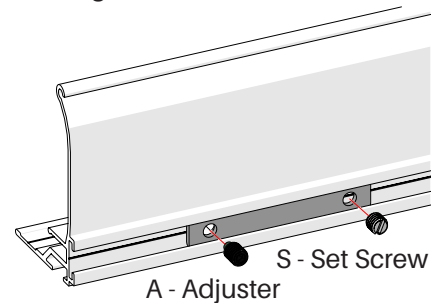
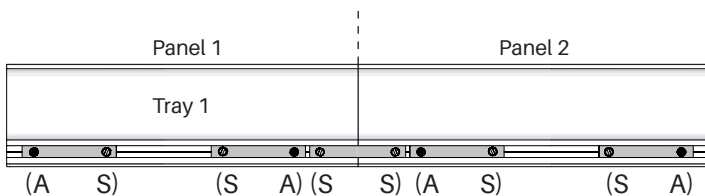

Panel Seam and Tray Splice Offset (Odd Number of Panels)

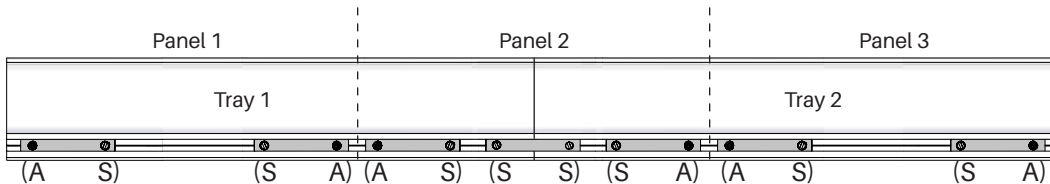

Complete tray assembly by pressing in Tray Ends (C1 and C2).

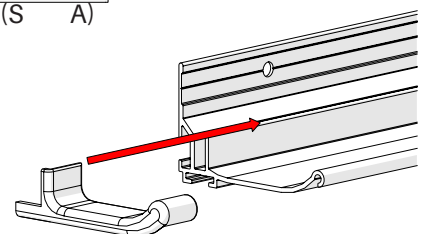

STEP 2

Mounting glass board tray to wall.

Place tray in desired location on wall. Mark anchor points using pre-drilled holes in back of tray piece. Install anchors at any mark not on a stud. Use drywall anchors (D5) or masonry anchors (D4) as needed and follow with screw (D3) through tray holes. Add shims if necessary to ensure tray is straight on wall. Check with level.

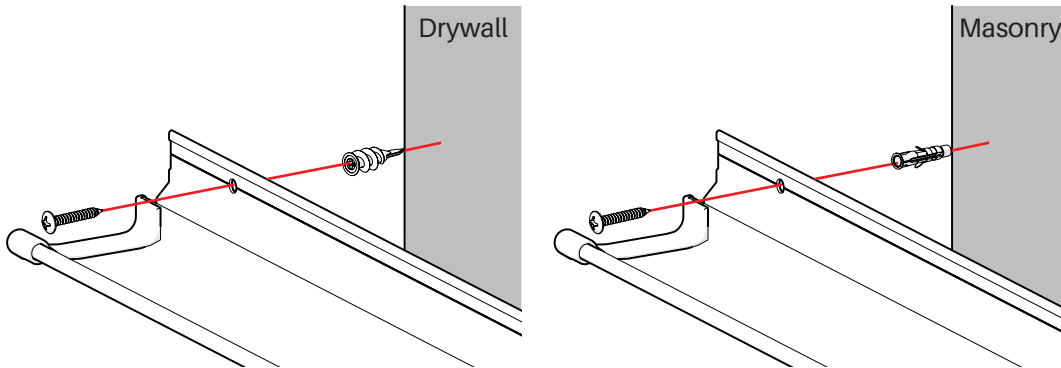

D3



D4

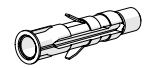

D5



Using an electric drill and a 3/16" bit, drill holes in tray at every stud between anchors. Be careful to drill through tray only, not all the way through the wall. Drive screws (D3) through drill holes and into studs. For some studs it may be necessary to pre-drill smaller pilot holes before driving in screws. Picture shown assumes 16" centers for stud spacing. For masonry or drywall installations space screws 2 feet apart.

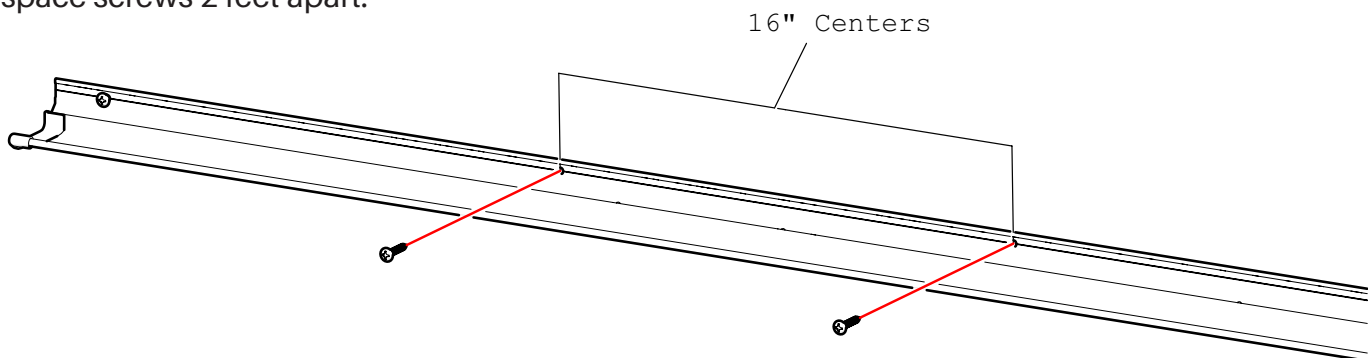

STEP 3

Install wall mounts.

Measure vertical distance up from tray where screws for mounts will be placed, using guide below. This should place screws 3/4" below top of panel once installed. Mark this distance on wall.

Distance between top edge of tray to wall mount screw center:

Panel Height (ft)	Distance X (")
4 ft	44 7/8"
6 ft	68 1/2"
8 ft	92 1/8"

***Due to slight variations in walls make sure to check measurements first with one panel and make adjustments before proceeding to install all wall mounts

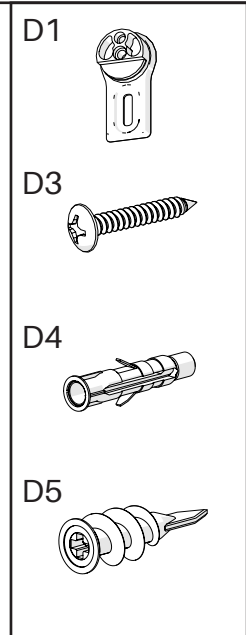

Next determine horizontal mount placement. One mount should be spaced within 6" in from either edge of each panel. For 4ft wide panels this is sufficient. For 6ft and 8ft wide panels add 1 and 2 more mounts respectively, evenly spaced. Use pre-drilled holes in tray as a reference to identify where panel seams will be. For edges of board note that panels will extend 0.5-1" past tray.

After marking wall, pre-drill holes for screws. Pre-drill 1/8" holes if going directly into a stud and 1/4" holes if using either anchor. Screws (D3) should be driven through slots on wall mounts into anchors (D4 or D5) or directly into stud. Mounts should be snug against wall but not so tight as to prevent them from sliding up on the wall with the screws in place.

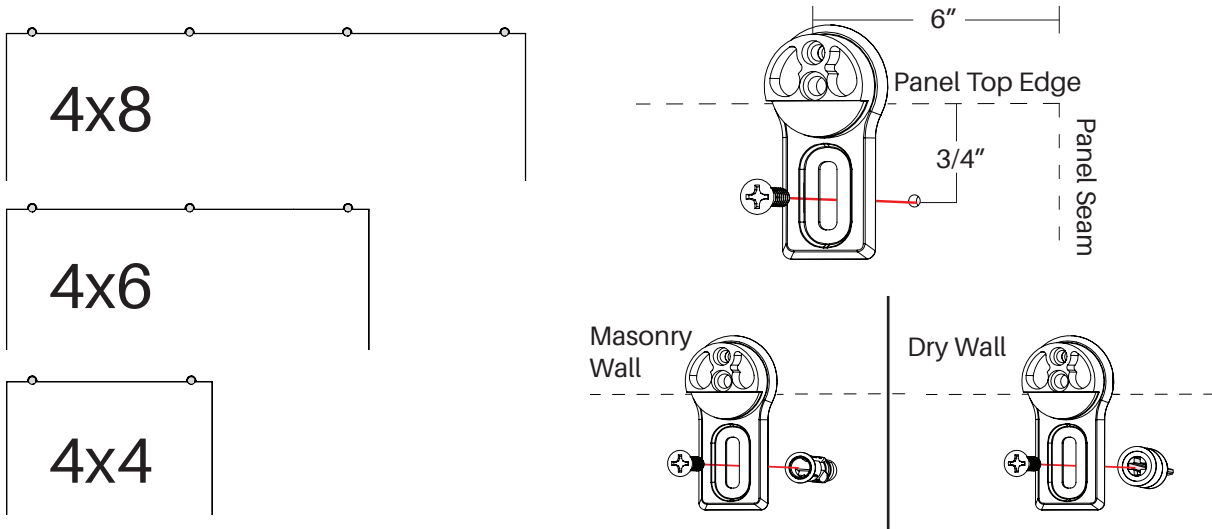

STEP 4

For multiple panel installations only - Attach adhesive pads to wall.

Remove backer off adhesive strips on one side of pads. Apply pad directly to wall being careful to center it along where vertical panel seam will be. Identify location of panel seams by marking halfway points between adjuster screw pairs above tray. Picture a vertical line extending from these marks up to wall mounts. This should be roughly where panel seam will be. Be sure tape strips are vertical during placement.

B1

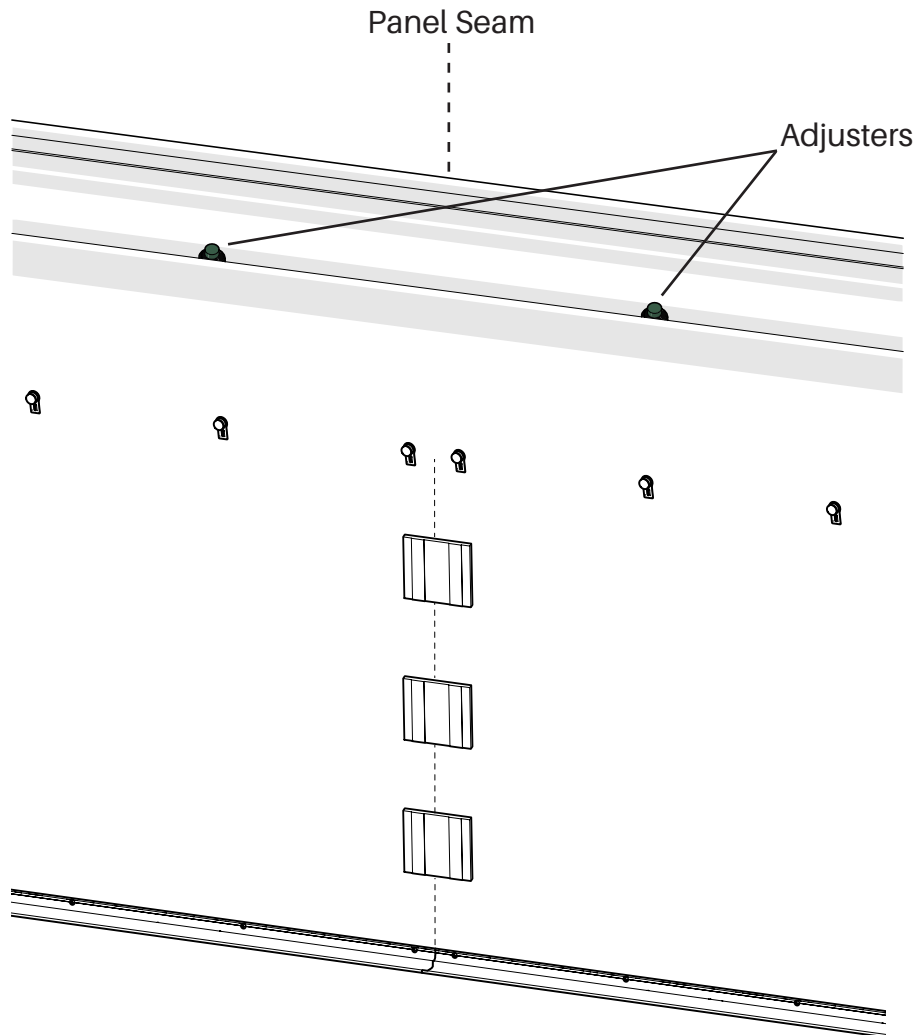
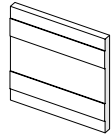

If installing 6 feet or 8 feet high panels, use no less than 3 pads per seam. For 4 foot tall boards 2 pads should be sufficient.

STEP 5

Attach adhesive pads to panel backs.

B1

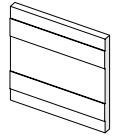

Peel one side of backer off adhesive pads (B1) and apply to back of glass panels. See pictures below for pad placement. Each panel will receive at least two pads regardless of size. Do not peel backer on other side.

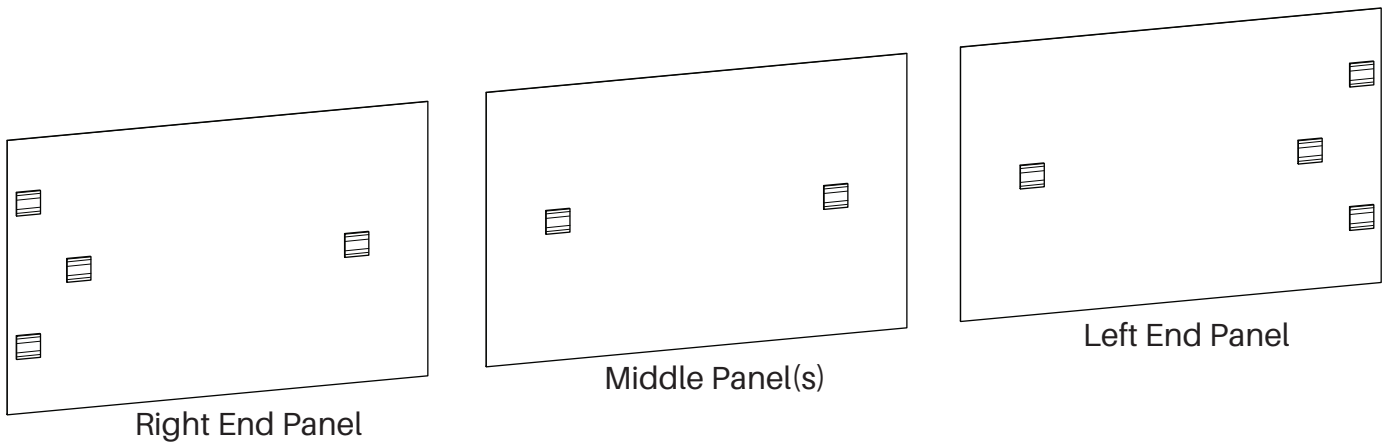

For 6 ft boards pads should be placed approximately 12" from left and right edges whether panel is positioned horizontally or vertically. Pads should be vertically centered on the panel. For 8 ft boards space pads 24" from either edge. The two end panels should get two extra pads applied to each to brace the edges. These should be placed as close to the edge as possible without being visible (2-3").

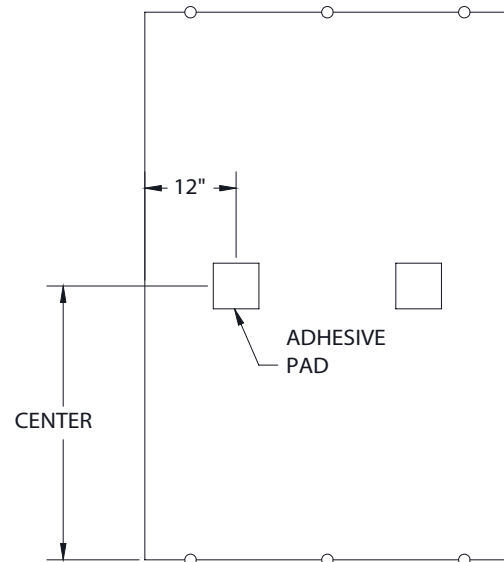
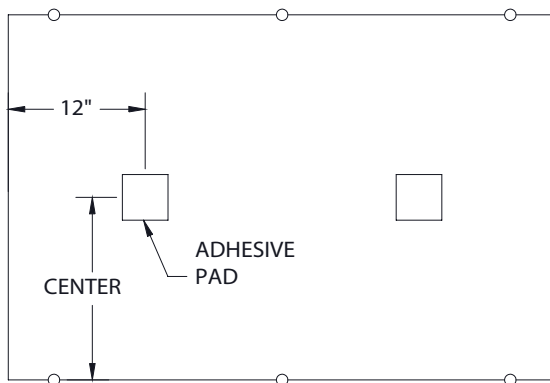

STEP 6

Set panels into tray and secure to mounts.

Insert bottom of panel into tray at an angle then push top towards wall.

D2

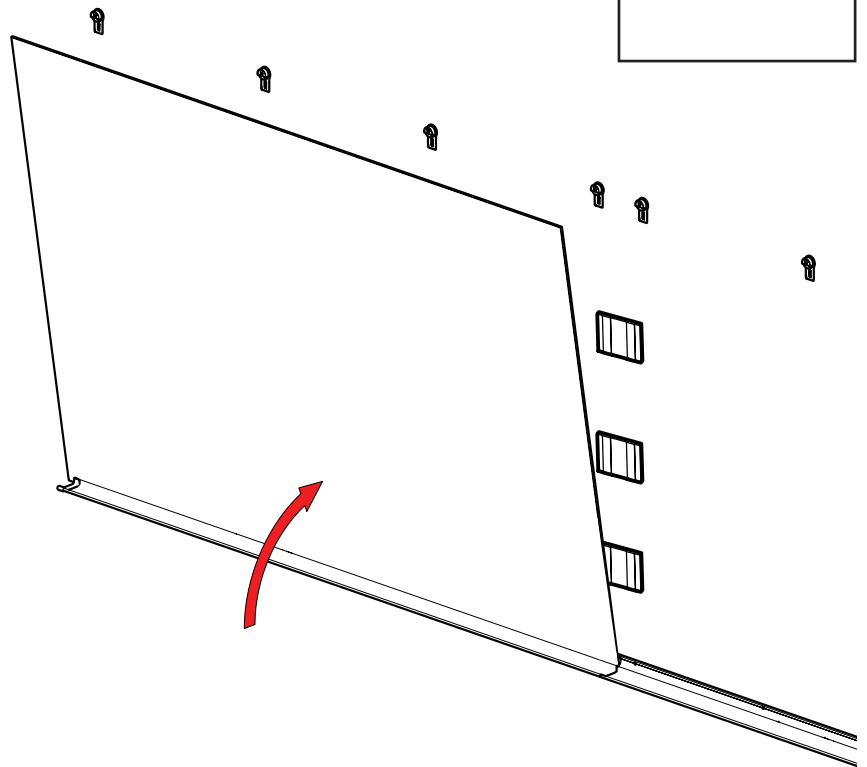
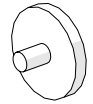

Once top of panel is positioned vertically, slide down wall mounts into position shown. Screw in at least two outer caps (one at each end of panel) just to hold panel in place. Repeat until all panels are up on wall.

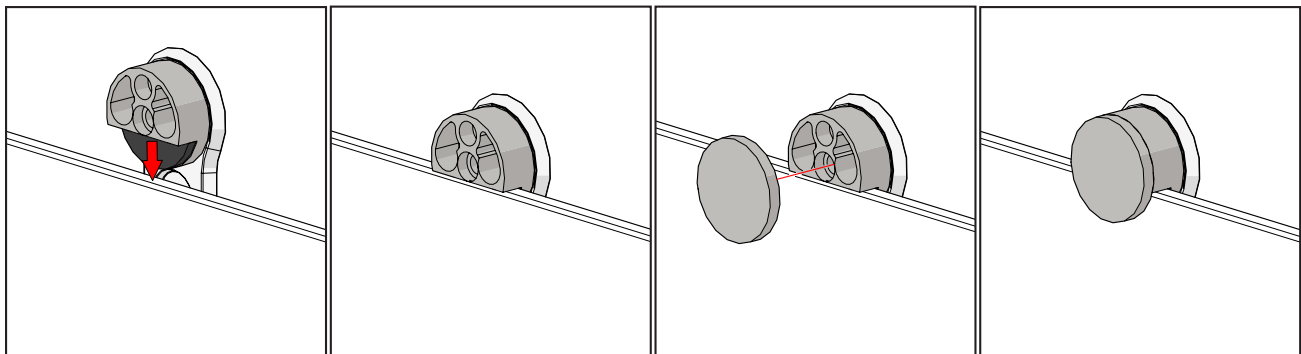

STEP 7

Adjust panel height at seams.

Using adjusters previously inserted in tray, raise and lower panels to ensure flush seams across entire board. Use pictures below as guides in deciding where to make panel height adjustments.

Situation 1: Gap at bottom of seam

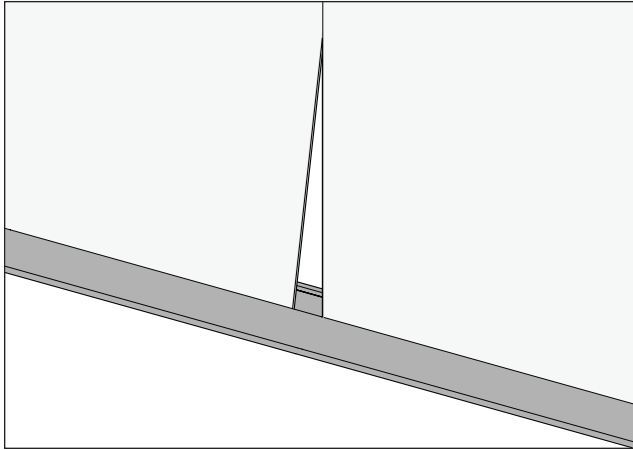

Raise adjusters on one or both panels nearest the gap.

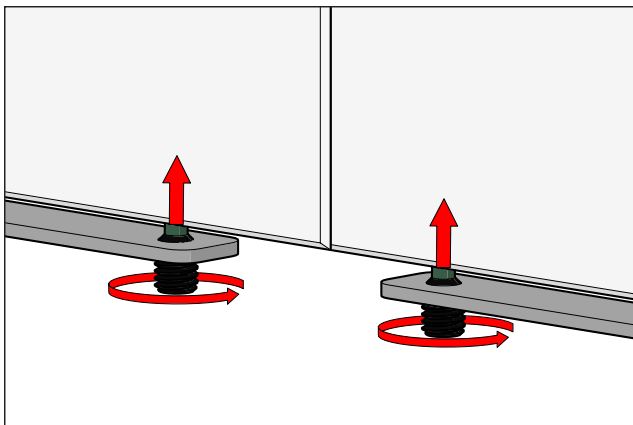

Situation 2: Gap at top of seam

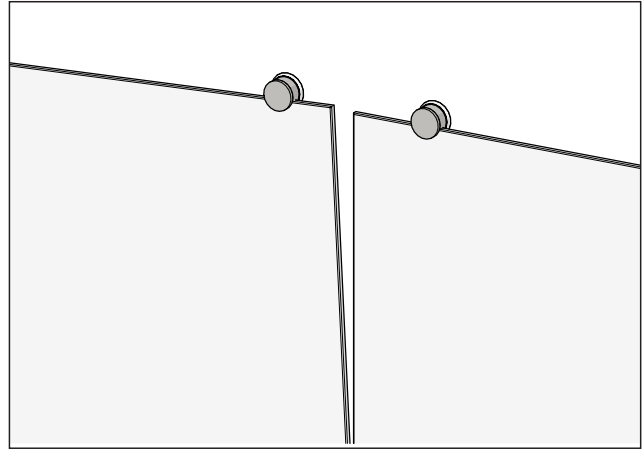

Lower adjusters on one or both panels nearest the gap.

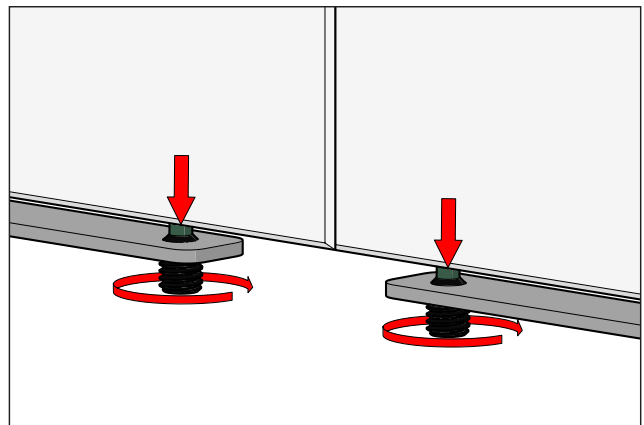

STEP 8

Remove adhesive and stick panels to wall.

With all adjustments complete, adhesive backers on pads (A1) can be removed and panels stuck to wall. Start with one panel on either end of board. Remove outer caps on any mounts holding panel then lower panel away from wall without removing from tray. Lower enough that backer on both adhesive pads on board and visible strips on wall can be peeled off.

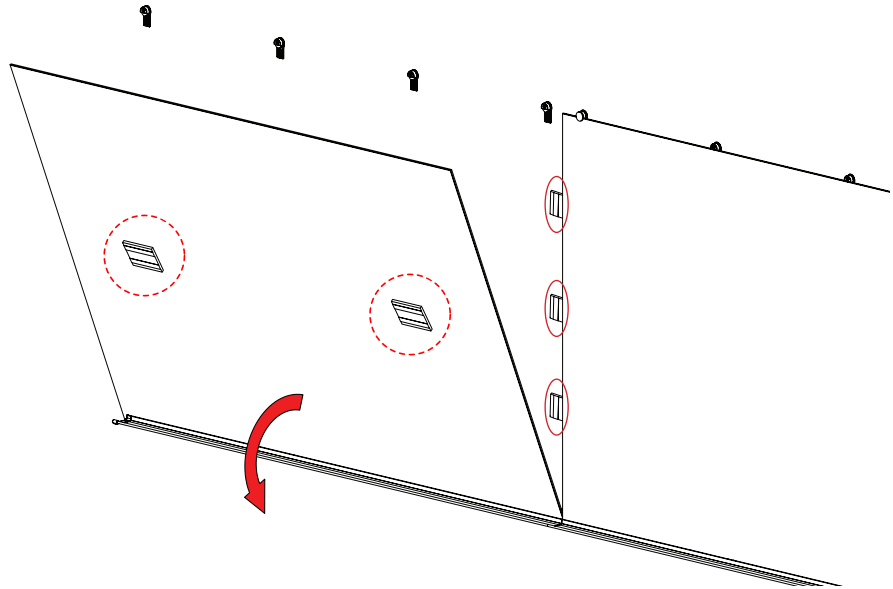

Carefully push panel back into wall so adhesives contact wall and panel. Once complete screw in outer caps to all wall mounts to secure panel. Move on to adjacent panel and repeat step until all panel adhesives have been placed. Be sure to remove backer from both strips of all pads placed at panel seams.

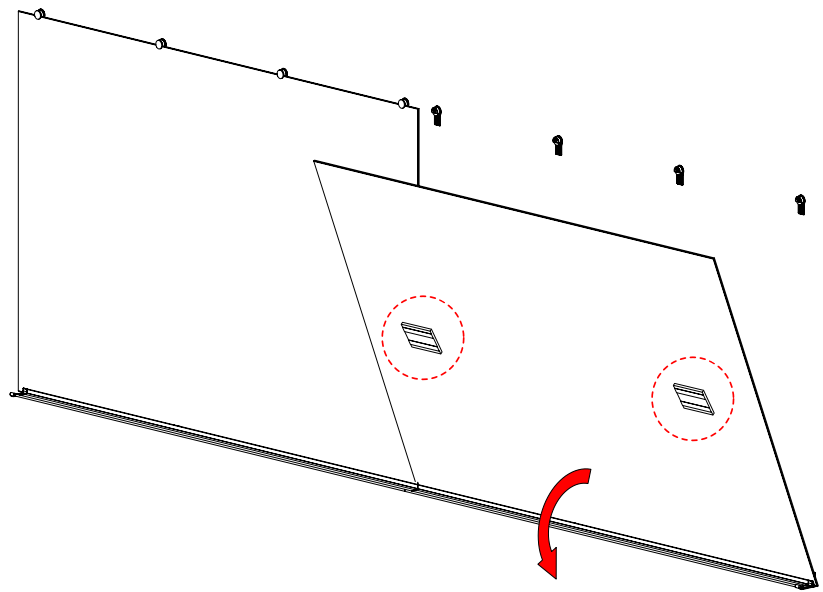

THIS COMPLETES ASSEMBLY INSTRUCTION