

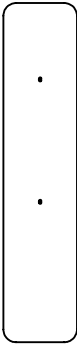

Reed Partition / RDXXXX

Installation Instructions

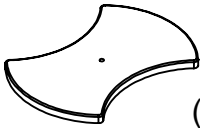
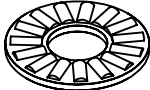
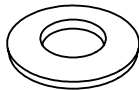
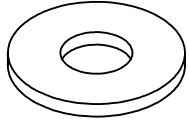
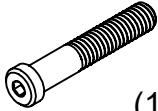
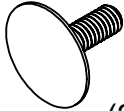
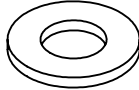
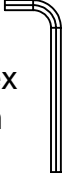

Step 1: Remove and unpack the Panels, Rails, and Hardware.

 <p>(1) Panel</p>	 <p>(1) Rail</p>	 <p>(1) Base</p>	 <p>(2) Bearing</p>	 <p>(2) Spring Washer</p>	 <p>(1) Black Washer</p>
		 <p>(1) 5/16-18 Screw</p>	 <p>(2) Button Screw</p>	 <p>(2) Flat Washer</p>	 <p>(1) 5/32" Hex Wrench</p>

Step 2: Assemble the Base as shown using the 5/16-18 Screw with a Flat Washer, then a Bearing, and finally a Spring Washer. Please note the Spring Washer should have the cone pointed towards the Bearing.

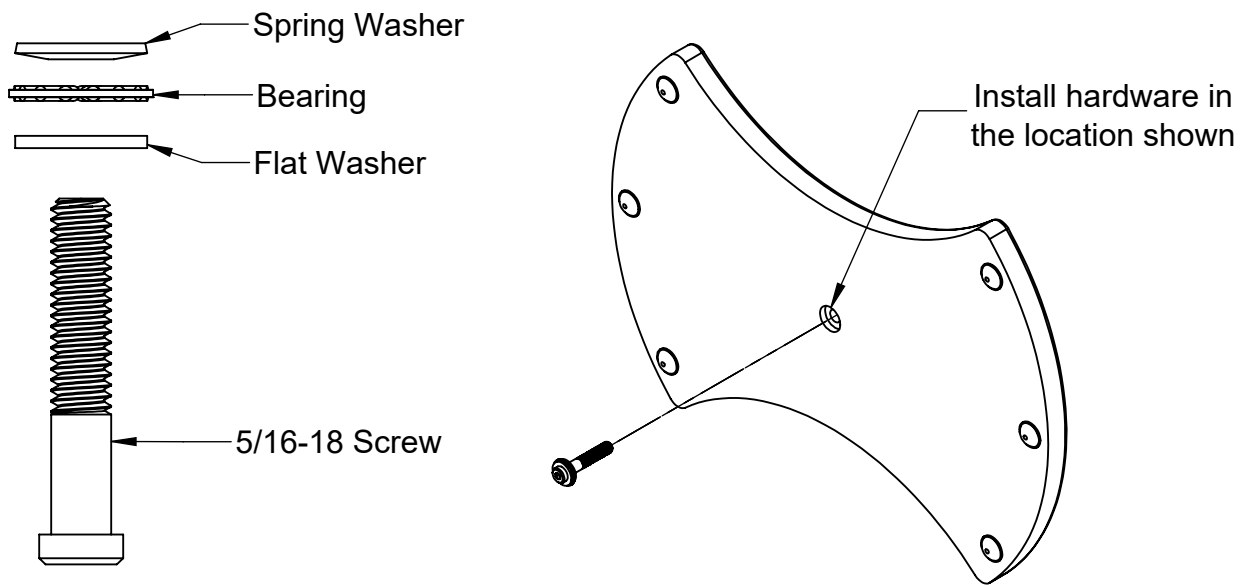

Step 3: Add the remaining hardware to the top of the Base as shown.

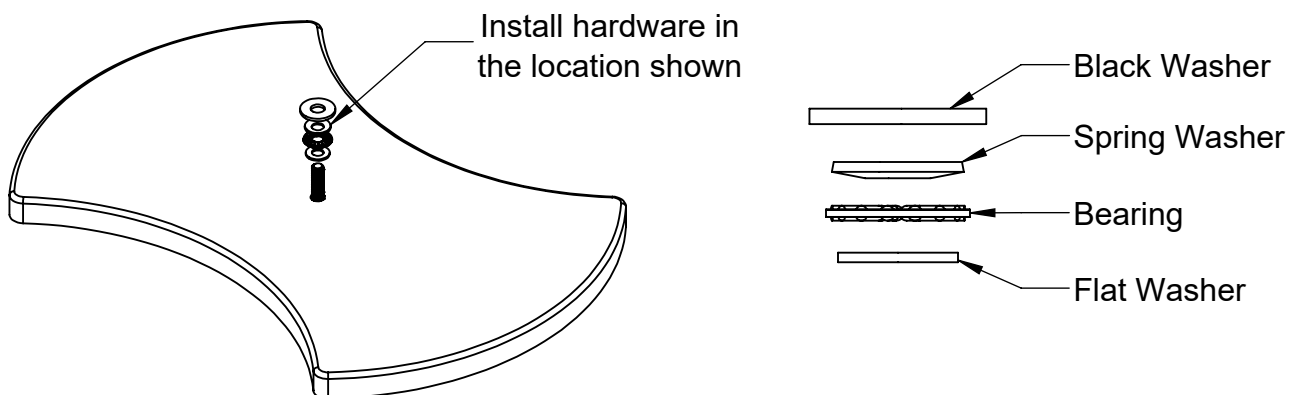

Reed Partition / RDXXXX

Installation Instructions

Step 4: Add the Rail to the top of the Base, then tighten 5/16-18 Screw using the 5/32 Hex Wrench. Verify that twisting the Rail does not loosen the 5/16-18 Screw.

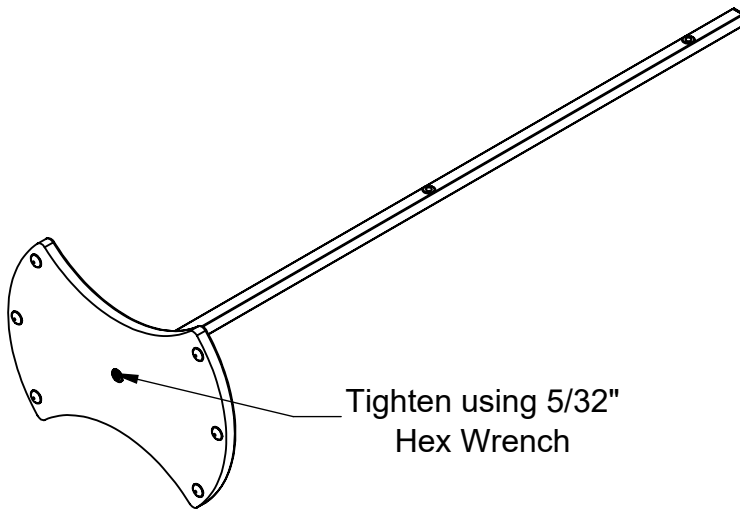

Notes

If the 5/16-18 Screw loosens when twisting the Rail, verify that the hardware was installed correctly per steps 2 and 3.

If the issue persists use an off-the-shelf thread locking adhesive on the 5/16-18 Screw to prevent loosening.

Step 5: Stand the Base upright and attach the Panel using the Button Screws. Select the desired product height and connect multiple units

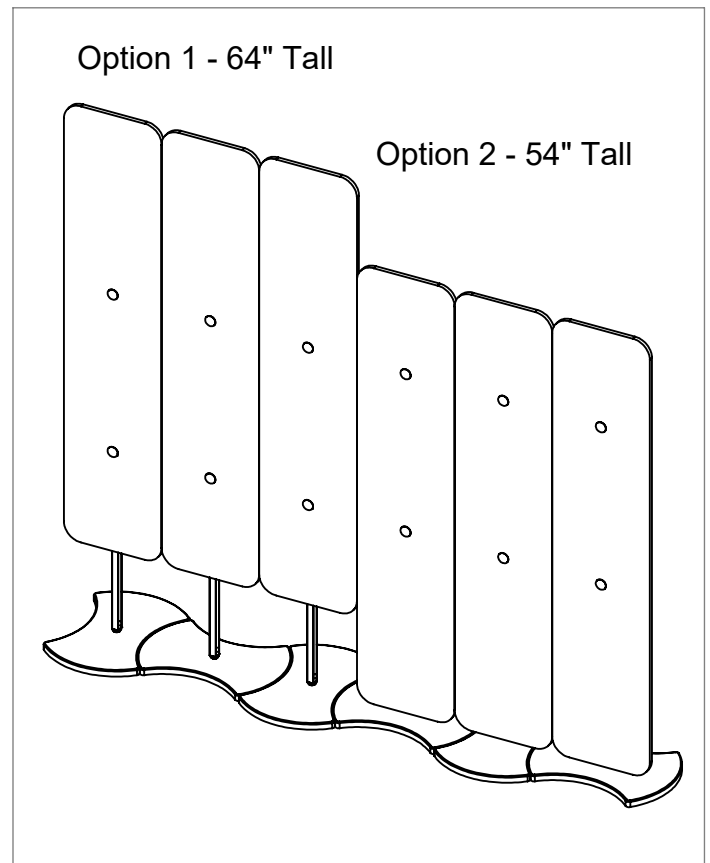
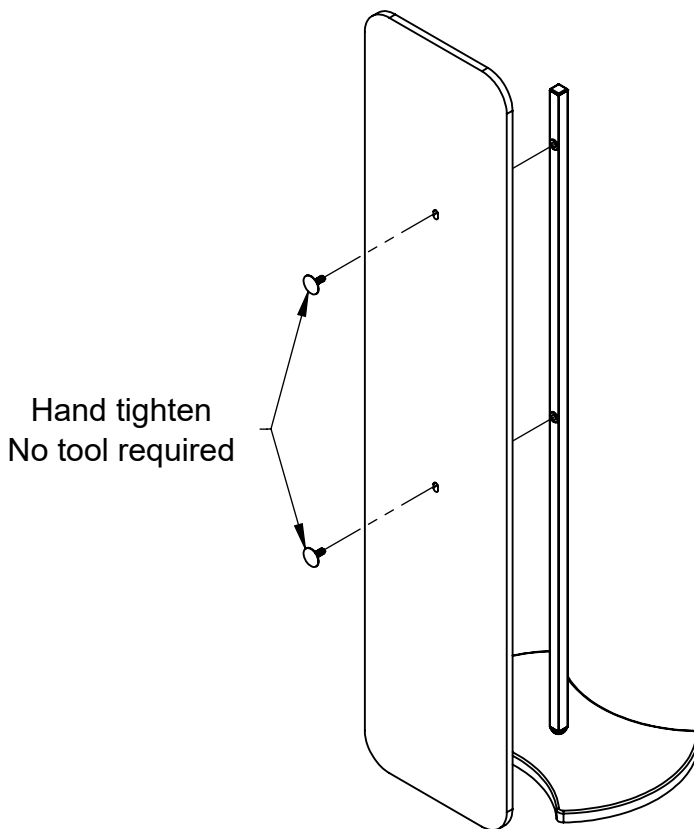

Step 6: Recycle all packaging in accordance with local regulations.