

Fixed Partition (FPM1M1)

Instruction Sheet

Step 1: Remove and unpack carton contents.

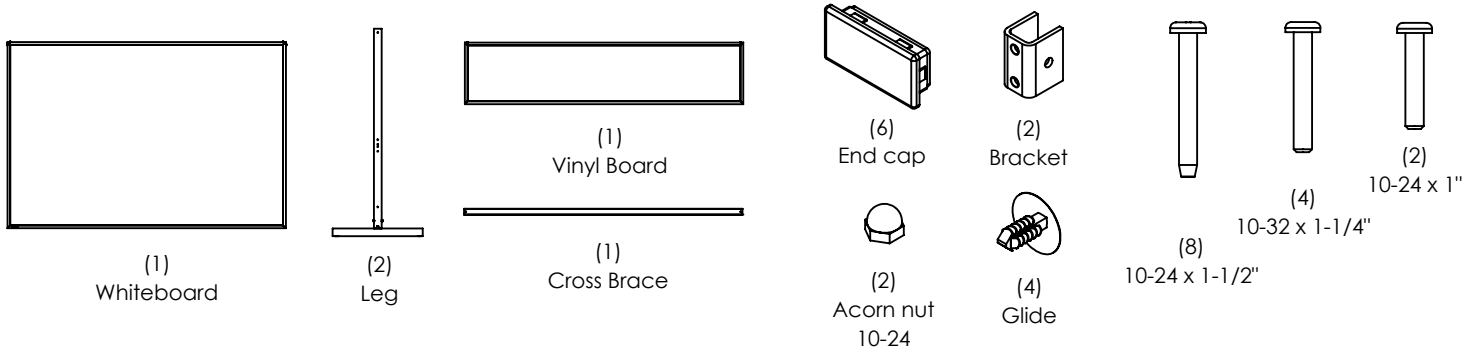

Step 2: Install the glides and end caps.

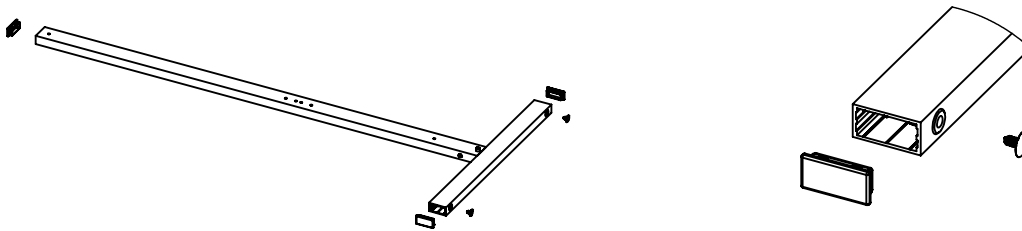

Step 3: Install bracket onto legs using 10-32 x 1-1/4" screws, thread screws into bracket. Do not tighten.

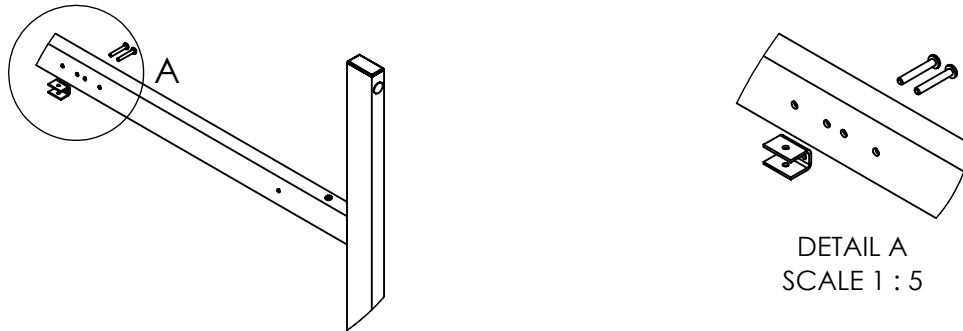

Step 4: Using a table (6) feet or more in length, organize the legs and cross brace as shown below, hand tighten 10-24 x 1" screws with acorn nuts.

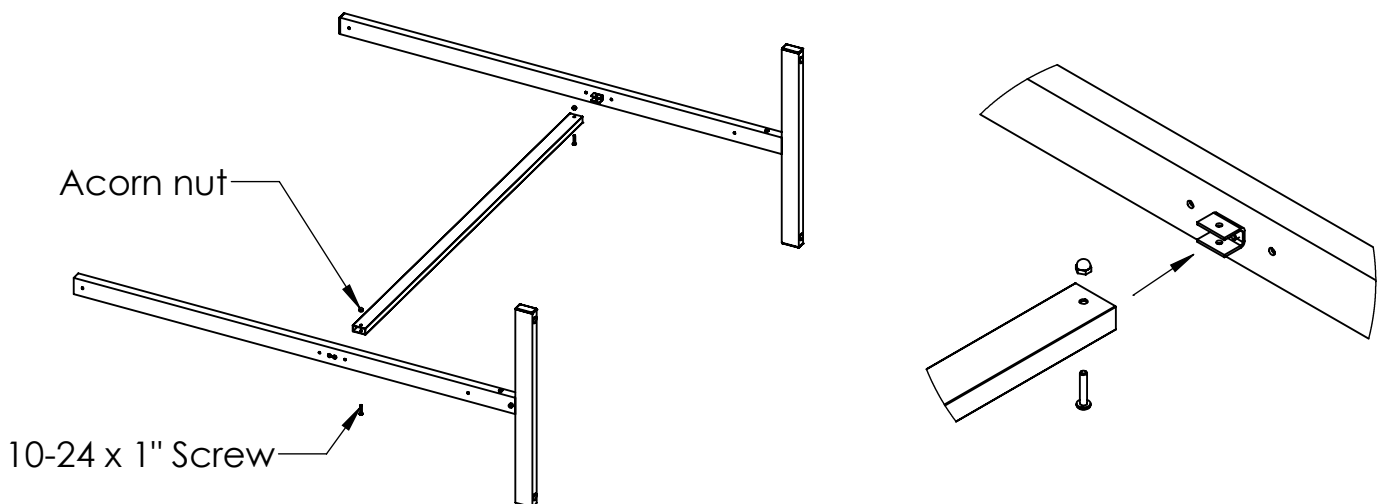

Step 5: Install the vinyl board and the whiteboard as shown below.

- 4a. Align both boards flush with the cross brace. Check remaining screw holes to verify that the boards are oriented properly.
- 4b. Use 10-24 x 1-1/2" screws to mount both panels onto the legs hand tight.
- 4c. Tighten all screws.
- 4d. Carefully remove the Fixed Partition unit from the table by carrying the legs. Then move to the intended location.

