

Jr. Partition

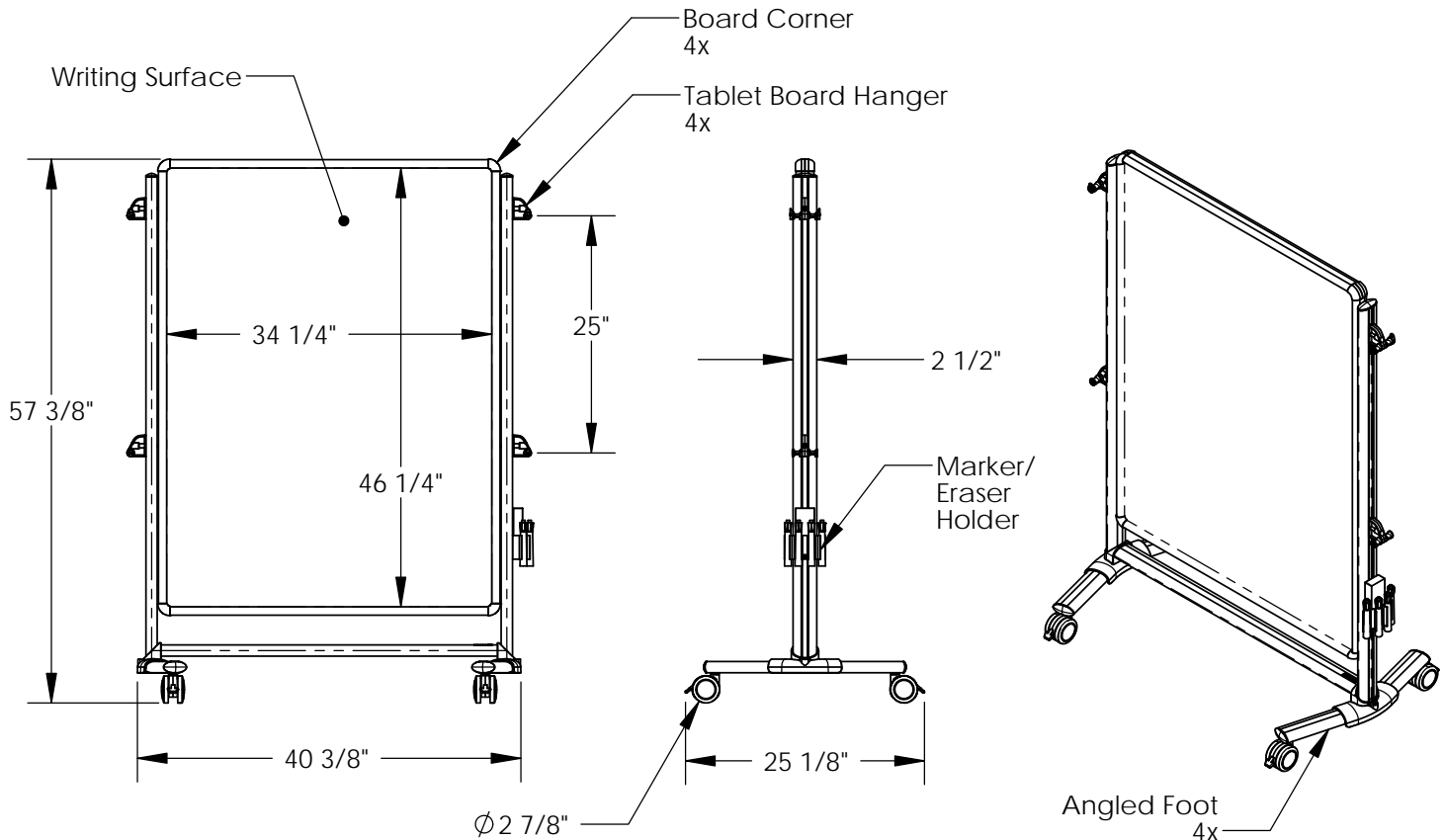

Materials:

- Framing and Eraser/Marker Holder: Satin anodized aluminum extrusion
- Foot Castings: Powder coated die cast aluminum
- Writing Surfaces: White porcelain coated 28 gage steel sheet
- Board Corners, Rail Caps, Tablet Hangers, and Hanger Pegs: Gray thermoplastic
- Swivel Casters with Wheel Locks: Thermoplastic Elastomer

Features:

- Writing surface on front and back.
- Has angled feet for grouping with other Nexus partitions, easels and/or IdeaWalls
- Includes 1 eraser and 4 assorted color dry erase markers.
- Designed to accommodate 4 Nexus Tablets - hung from the side posts.
- Guaranteed for 10 years

Notes:

- Some assembly required
- Related Products: Nexus X-Pegs, Nexus Caddy, Nexus Tablet, Nexus Easel, and Nexus IdeaWall