

OPERATION MANUAL

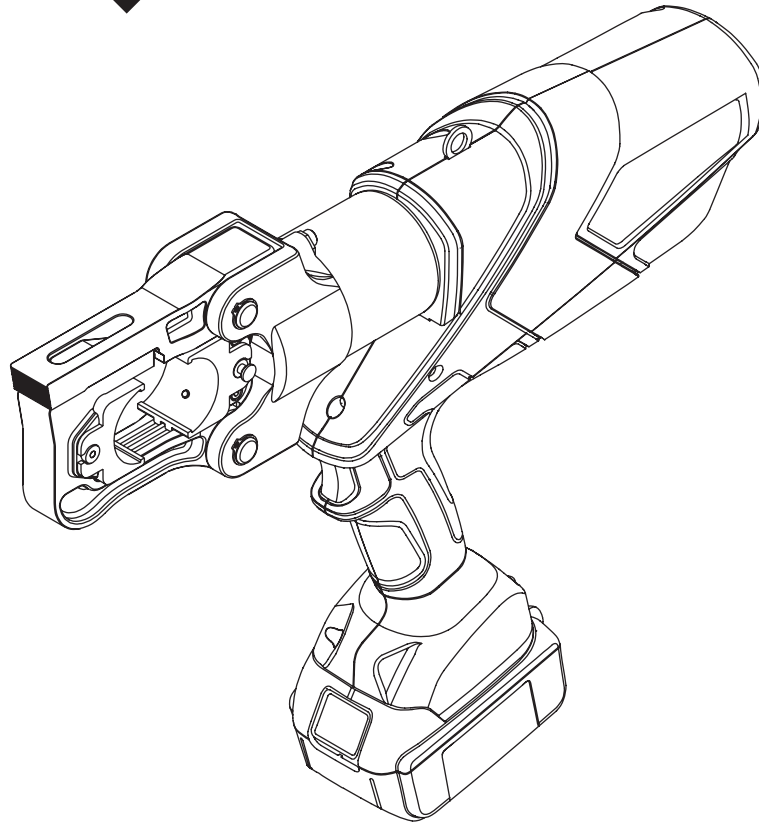

GREENLEE®
A Textron Company

Serial Number



E12CCXLT and E12CCXLX GATOR® Battery-powered, 12-ton Tools



Read and understand all of the instructions and safety information in this manual before operating or servicing this tool.

Register this product at www.greenlee.com



Table of Contents

Description 2

Safety 2

Purpose of this Manual 2

Important Safety Information 3-4

Identification 5

Specifications 5

Operation 6-15

 Crimping Using KC12 or KA12 type U-style Dies... 7-8

 Crimping Using UA12ID Dieless Die Set 9

 Cutting 10

 Punching 11-15

Die Selection 16

Connector Selection 16

Additional U-type Dies 17

Available Accessories 17

cUL and UL Classified Crimps 18

Connector Table 18

LCD Screen 19

Maintenance 20

Troubleshooting 21

Description

The E12CCXLT and E12CCXLX 12-ton Battery-powered, High-speed Tools are hand-held, self-contained tools intended to crimp cable, cut cable and threaded rod, and punch holes with the proper adapters.

These tools have a retraction stop feature which allows the operator to stop the retraction motion of the ram to shorten cycle time.

Both the T and X versions of this tool have Bluetooth® connectivity and an LCD screen. Only the T version has GPS tracking.

These tools are protected by U.S. Patent No. 6,206,663, 6,276,186, 6,401,515, 6,532,790, and 6,718,870.

E12CCXLT—FCC ID: 2AGL2COM; IC ID: 20646COM
E12CCXLX—FCC ID: 2AGL2CFM; IC ID: 20646CFM

This device complies with Part 15 of the FCC Rules. Operation is subject to the following two conditions: (1) this device may not cause harmful interference, and (2) this device must accept any interference received, including interference that may cause undesired operation.

Safety

Safety is essential in the use and maintenance of Greenlee tools and equipment. This manual and any markings on the tool provide information for avoiding hazards and unsafe practices related to the use of this tool. Observe all of the safety information provided.

Purpose of this Manual

This manual is intended to familiarize all personnel with the safe operation and maintenance procedures for the following Greenlee tools:

- E12CCXLT 12-ton Battery-powered, High-speed Tool
- E12CCXLX 12-ton Battery-powered, High-speed Tool

Keep this manual available to all personnel.

Replacement manuals are available upon request at no charge at www.greenlee.com.



Do not discard this product or throw away!

For recycling information, go to www.greenlee.com.

All specifications are nominal and may change as design improvements occur. Greenlee Textron Inc. shall not be liable for damages resulting from misapplication or misuse of its products.

GATOR and Kwik Stepper are registered trademarks of Textron Innovations Inc.

Bluetooth is a registered trademark of Bluetooth SIG, Inc.

Blackburn is a registered trademark of Thomas & Betts.

KEEP THIS MANUAL



IMPORTANT SAFETY INFORMATION



SAFETY ALERT SYMBOL

This symbol is used to call your attention to hazards or unsafe practices which could result in an injury or property damage. The signal word, defined below, indicates the severity of the hazard. The message after the signal word provides information for preventing or avoiding the hazard.

⚠ DANGER

Immediate hazards which, if not avoided, **WILL** result in severe injury or death.

⚠ WARNING

Hazards which, if not avoided, **COULD** result in severe injury or death.

⚠ CAUTION

Hazards or unsafe practices which, if not avoided, **MAY** result in injury or property damage.

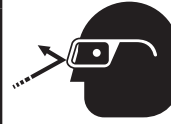

⚠ WARNING

Wear eye protection when operating or servicing this tool.

Failure to wear eye protection could result in serious eye injury from flying debris or hydraulic oil.



⚠ WARNING

Skin injection hazard:

Do not use hands to check for oil leaks. Oil under pressure easily punctures skin. If injured, seek medical attention immediately to remove oil.

Failure to observe this warning could result in serious injury, gangrene, or death.



⚠ WARNING

Do not use solvents or flammable liquids to clean the tool body. Solvents or flammable liquids could ignite and cause serious injury or property damage.



⚠ WARNING

Read and understand all of the instructions and safety information in this manual before operating or servicing this tool.

Failure to observe this warning could result in severe injury or death.



⚠ WARNING

Electric shock hazard:

This tool is not insulated. When using this unit on or near energized electrical lines, use proper personal protective equipment.

Failure to observe this warning could result in severe injury or death.

⚠ WARNING

An incomplete crimp can cause a fire.

- Use proper die, connector, and cable combinations. Improper combinations can result in an incomplete crimp.
- The relief valve sounds and the ram automatically retracts to indicate a completed crimp. If you do not hear the sound of the relieve valve or the ram does not automatically retract, the crimp is not complete.

Failure to observe these warnings could result in severe injury or death.



⚠ WARNING

Pinch points:

- Remove battery before changing dies, adapters, or jaws.
- Keep hands away from the crimping tool head when crimping.

Failure to observe these warnings could result in severe injury or death.



IMPORTANT SAFETY INFORMATION

⚠ WARNING

Do not dispose of batteries in a fire. They will vent fumes and may explode.

Failure to observe this warning could result in severe injury from harmful fumes or burns from flying debris.

⚠ WARNING

Remove the battery before transporting the T version of this tool by air.

Failure to observe this warning could result in severe injury or death.

⚠ WARNING

- Inspect tool and dies before use. Replace any worn or damaged parts. A damaged or improperly assembled tool can break and strike nearby personnel.
- Carrying strap is for carrying only, not to be used to hang or suspend tool.

Failure to observe these warnings could result in severe injury or death.

⚠ CAUTION

- Do not use this tool for continuous use. After 30 to 40 cycles, allow the tool to cool for 15 minutes.
- Do not secure this tool in a vise. This tool is designed for hand-held operation.
- This tool may be used in damp or wet environments; however, air-drying is recommended before use if the tool becomes soaked. Damage may result when the tool is operated prior to thorough drying when electrical components are soaked.
- Use this tool for the manufacturer's intended purpose only.

Failure to observe these precautions may result in injury or property damage.

⚠ CAUTION

Do not allow anything to contact the battery terminals.

- Do not immerse the batteries in liquid. Liquid may create a short circuit and damage the battery. If batteries are immersed, contact your service center for proper handling.
- Do not place the battery into a pocket, tool pouch, or tool box with conductive objects. Conductive objects may create a short circuit and damage the battery.
- Do not place a battery on moist ground or grass. Moisture may create a short circuit and damage the battery.

Failure to observe these precautions may result in injury or property damage.

⚠ CAUTION

- Do not store the battery at more than 122 °F (50 °C) or less than -4 °F (-20 °C). Damage to the battery can result.
- Do not use another manufacturer's charger. Other manufacturers' chargers may overcharge and damage the battery.
- Do not attempt to open the battery. It contains no user-serviceable parts.

Failure to observe these precautions may result in injury or property damage.

⚠ CAUTION

Do not perform any service or maintenance other than as described in this manual. Injury or damage to the tool may result.

Failure to observe this precaution may result in injury and property damage.

Note: Keep all decals clean and legible, and replace when necessary.



Identification

- 1. LED Work Light (white)
- 2. Adapter Release Buttons
- 3. Head
- 4. Latch (for opening head)
- 5. Lanyard Ring
- 6. Housing
- 7. Retract Button
- 8. LED Indicator (red)
- 9. LCD Screen
- 10. Battery
- 11. Trigger

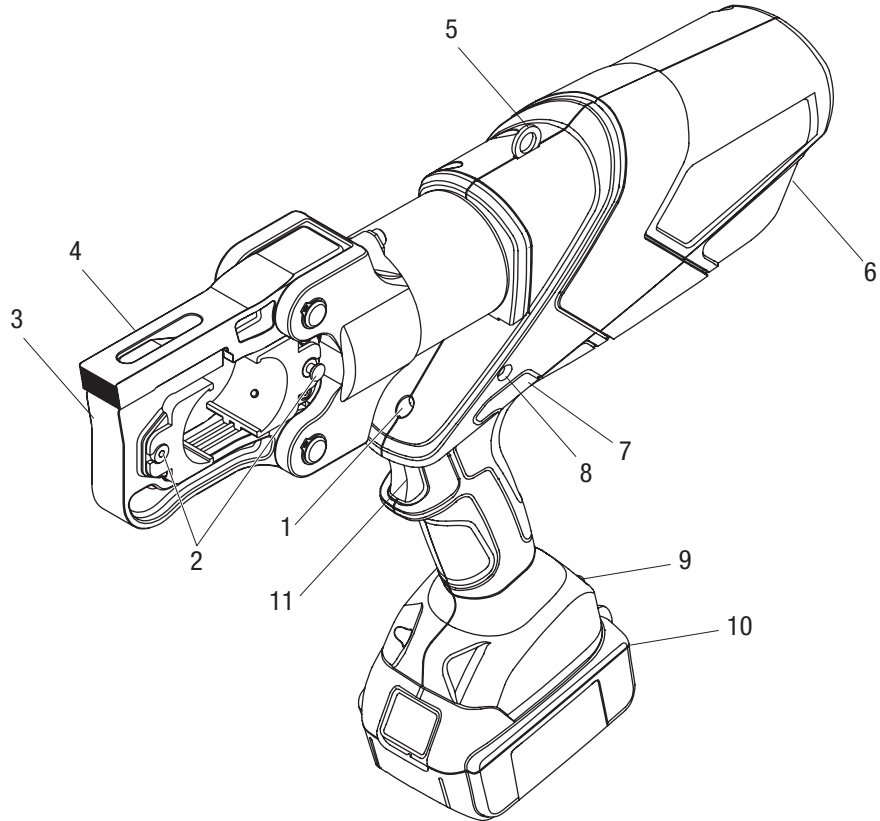

Specifications

Tool

- Length 17.5" (444 mm)
- Width 3.00" (76 mm)
- Height (with battery) 13.4" (341 mm)
- Weight 19.5 lb (8.87 kg)
- Crimping Force 12 tons (106 kN)
- Hydraulic Oil..... 52057878 biodegradable hydraulic fluid
- Recommended Operating Temperature Range 5 °F to 122 °F (-15 °C to 50 °C)

Battery Charger

Read the instructions supplied with the battery charger

Crimping Capacities

- Copper Color-Coded Lugs and Splices 750 kcmil
- Aluminum Color-Coded Lugs and Splices 750 kcmil
- UA12ID Dieless Die Crimping Range
 - Copper Color-Coded Lugs and Splices 4 AWG–750 kcmil
 - Aluminum Color-Coded Lugs and Splices 6 AWG–600 kcmil
- 5/8" Service Entrance Connectors 10–1/0 AWG
- .840 Service Entrance Connectors 1/0–4/0 AWG
- Aluminum Overhead "H" Taps 6 AWG–500 kcmil
- One-Piece ACSR Tension Splices 4 AWG–556.5 kcmil
- Two-Piece ACSR Tension Splices 2 AWG–556.5 kcmil

Cutting Capacities

- Copper and Aluminum Cable 1-1/2" (40 mm)
- ACSR 954 kcmil (Cardinal)
- Standard Guy Strand 5/8"
- EHS Guy Strand 1/2"
- Ground Rod 1/2" (13 mm)
- Rebar (schedule 60) 1/2" (13 mm)
- Threaded Rod 1/4", 3/8", 1/2"

Punching Capacities

- Round 5-5/8" (144.1 mm) in 10 ga. mild steel
- Rectangular 2.677" x 5.433" (68.0 mm x 138.0 mm)
- Square 5.433" x 5.433" (138.0 mm x 138.0 mm)
- Accessories required to punch ø 4" through ø 5-5/8": 12185 spacer, 04686 bushing, and 03170 sleeve



Operation

⚠ WARNING

- Inspect tool and dies before use. Replace any worn or damaged parts. A damaged or improperly assembled tool can break and strike nearby personnel.
- Carrying strap is for carrying only, not to be used to hang or suspend tool.

Failure to observe these warnings could result in severe injury or death.

⚠ CAUTION

- Do not use this tool for continuous use. After 30 to 40 cycles, allow the tool to cool for 15 minutes.
- Do not secure this tool in a vise. This tool is designed for hand-held operation.
- This tool may be used in damp or wet environments; however, air-drying is recommended before use if the tool becomes soaked. Damage may result when the tool is operated prior to thorough drying when electrical components are soaked.
- Use this tool for the manufacturer’s intended purpose only.

Failure to observe these precautions may result in injury or property damage.



⚠ WARNING

Electric shock hazard:

This tool is not insulated. When using this unit on or near energized electrical lines, use proper personal protective equipment.

Failure to observe this warning could result in severe injury or death.

Charging the Battery

Read the instructions supplied with the battery charger.

LED Work Light (white)

This LED automatically turns on when the trigger is pulled. It remains on for 10 seconds after the trigger is released.

LED Indicator (red)

This tool is equipped with a special circuit board incorporating several important features to inform the user about the current status of the unit. The LED signals in the following cases:

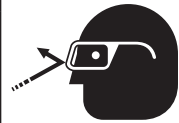

⚠ WARNING

Wear eye protection when operating or servicing this tool.

Failure to wear eye protection could result in serious eye injury from flying debris or hydraulic oil.

What happens	Signal	What it means
Constant light for 20 seconds at end of cycle	█	Battery charge is below 17 V at beginning of cycle*
Tool will not start, and constant light for 20 seconds when trigger is released	█	Battery charge is below 16 V at beginning of cycle*
Tool will stop, and constant light for 20 seconds after trigger is released	█	Battery voltage drops below 13 V during cycle*
Tool will stop, and flashing light for 20 seconds when trigger is released	●●●●	Motor current exceeds 20 A during cycle
		Circuit has become too hot
Flashing light for 20 seconds at end of cycle	●●●●	Send tool in for service

* Running the battery below 16 V can damage the battery.



⚠ WARNING

Pinch points:

- Remove battery before changing dies, adapters, or jaws.
- Keep hands away from the crimping tool head when crimping.

Failure to observe these warnings could result in severe injury or death.



Operation—Crimping Using KC12 or KA12 type U-style Dies

Setup

1. Open the tool head.
2. Remove any accessories from the tool head.
3. Select the appropriate set of die adapters and dies.
4. Install the UA12T adapters and U-style dies—one set in each groove. Lock the die adapters in place with the detents.

Important: Die adapters must be locked into place or the die detents will be damaged.

5. Visually check the dies to ensure that they are aligned correctly so that they will complete the crimping operation.
6. Close the tool head.

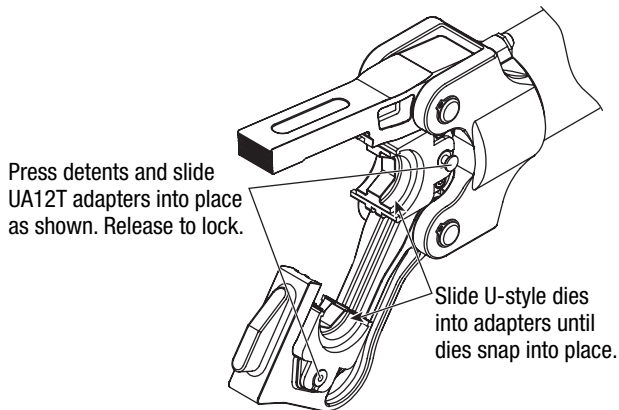

Preparing the Cable

Follow the lug manufacturer's instructions for appropriate cable strip length.

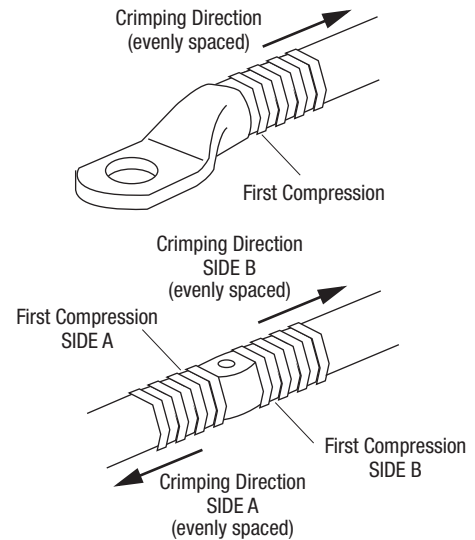



Operation—Crimping Using KC12 or KA12 type U-style Dies (cont'd)

Crimping Procedure

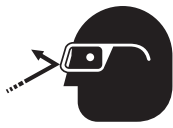
	⚠ WARNING
	<p>Wear eye protection when operating or servicing this tool.</p> <p>Failure to wear eye protection could result in serious eye injury from flying debris or hydraulic oil.</p>

⚠ WARNING
<p>An incomplete crimp can cause a fire.</p> <ul style="list-style-type: none"> • Use proper die, connector, and cable combinations. Improper combinations can result in an incomplete crimp. • The relief valve sounds and the ram automatically retracts to indicate a completed crimp. If you do not hear the sound of the relieve valve or the ram does not automatically retract, the crimp is not complete. <p>Failure to observe these warnings could result in severe injury or death.</p>

1. Press the latch and open the tool head.
2. Insert the properly assembled connector into the tool head.
3. Close the tool head.
4. Pull the trigger to make the crimp.
5. Hold the trigger down until the crimper achieves pressure relief.

Notes: Pressure relief occurs at approximately 106 kN bar (12 tons). If you do not hear a “pop,” the crimp is incomplete.

It is normal for the battery load display to light at both the beginning and near the end of the crimping cycle.

6. The ram returns automatically.
7. To stop the ram from returning fully, activate the trigger for a brief moment. This activation will close the retraction valve and stop the retraction motion.
8. Position the crimper for the next crimp. Repeat Steps 4 through 6 for the number of crimps as described in this manual.
9. Open the crimping head and remove the connector.

Notes: If it is necessary to retract the ram before a crimp cycle is completed, push the retract button. Pushing the retract button will result in complete retraction of the ram.

After completing the last crimp on an aluminum connector, wipe off the excess oxide inhibitor.

Retraction Stop

1. To stop the ram from returning fully, activate the trigger for a brief moment. This activation will close the retraction valve, stop the retraction motion, and set the semi-automatic retraction stop position.
2. Depress the trigger to advance the ram. Hold the trigger down until the ram automatically retracts. The ram will partially retract to the set position and allow the tool to be repositioned.
3. If full retraction is desired, release the trigger at the end of the crimp.



Operation—Crimping Using UA12ID Dieless Die Set

Setup

1. Open the tool head.
2. Remove any accessories from the tool head.
3. Install the UA12ID indenter against the ram and lock in place with the detent.
4. Install the UA12ID anvil into the head and lock in place with the detent.

Important: The indenter and anvil must be locked into place or the detents will be damaged.

5. Visually check the indenter and anvil to ensure that they are aligned correctly so that they will complete the crimping operation.
6. Close the tool head.

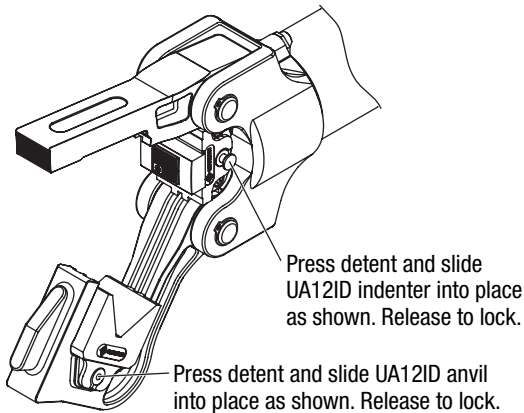

Preparation

IMPORTANT

For a cUL or UL classified crimp, refer to “Connector Table” in this instruction manual.

1. Select a proper size and type of connector to correspond with the wire or cable.
2. Strip the cable to an appropriate length. Follow the connector manufacturer’s instructions.

Note: Apply an oxide inhibitor, if required. Refer to the connector manufacturer’s instructions.

3. Clean the die seat area.

Crimping Procedure

1. Insert the cable fully into the connector.
2. Place the connector into the V of the crimping head as shown below.

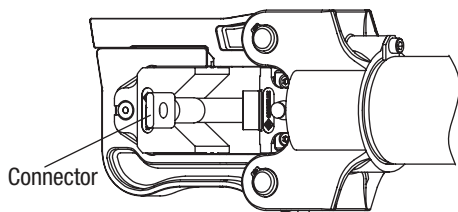

3. If open, close the crimping head. Make sure the head and latch are fully engaged.
4. For a cUL or UL classified crimp, complete the number of crimps specified under “Connector Table” in this manual.
5. For a single crimp, position the connector so the crimp will be located at the center of the barrel. For a double crimp, position the connector so two crimps will be evenly spaced between the connector marks.
6. Depress the trigger to advance the indenter. Hold the trigger down until the indenter automatically begins to retract.

Notes: If the crimping tool does not automatically retract, the crimp is incomplete.

It is normal for the battery load display to light at both the beginning and near the end of the crimping cycle.

7. Release the trigger until the indenter retracts completely.
8. To stop the ram from returning fully, activate the trigger for a brief moment. This activation will close the retraction valve and stop the retraction motion.
9. Lift the latch to open the crimping head and remove the connector.

Note: If it is necessary to retract the indenter before a crimp cycle is complete, push the retract button. Pushing the retract button will result in complete retraction of the indenter.

After completing the last crimp on an aluminum connector, wipe off the excess oxide inhibitor.

⚠ WARNING

An incomplete crimp can cause a fire.

- Use proper die, connector, and cable combinations. Improper combinations can result in an incomplete crimp.
- The relief valve sounds and the ram automatically retracts to indicate a completed crimp. If you do not hear the sound of the relieve valve or the ram does not automatically retract, the crimp is not complete.

Failure to observe these warnings could result in severe injury or death.

Automatic Retraction Stop

1. Depress the trigger to advance the indenter. Hold the trigger down until the indenter automatically retracts. The indenter will partially retract to allow the tool to be repositioned.
2. If full retraction is desired, release the trigger at the end of the crimp.



Operation—Cutting

	⚠ WARNING
	<p>Electric shock hazard: This tool is not insulated. When using this unit on or near energized electrical lines, use proper personal protective equipment. Failure to observe this warning could result in severe injury or death.</p>

	⚠ WARNING
	<p>Wear eye protection when operating or servicing this tool. Failure to wear eye protection could result in serious eye injury from flying debris or hydraulic oil.</p>

Accessory Table

Task	Blade
Copper and aluminum 26 mm (1.00") max.	UC26
Copper and aluminum 40 mm (1.56") max.	UC40
ACSR Copperweld ACAR Guy strand EHS guy strand Ground rod Anchor rod Soft bolts Rebar	UCACSR
Threaded rod	Threaded rod

Setup

1. Open the tool head.
2. Remove any accessories from the tool head.
3. Select the appropriate set of blades, using the table provided on this page.
4. Install one blade in each groove. Slide the tab into the slots in the ram and head. Lock them in place with the W-type detents.
5. Visually check the blades to ensure that they are aligned correctly so that they will complete the butting operation.
6. Close the tool head.

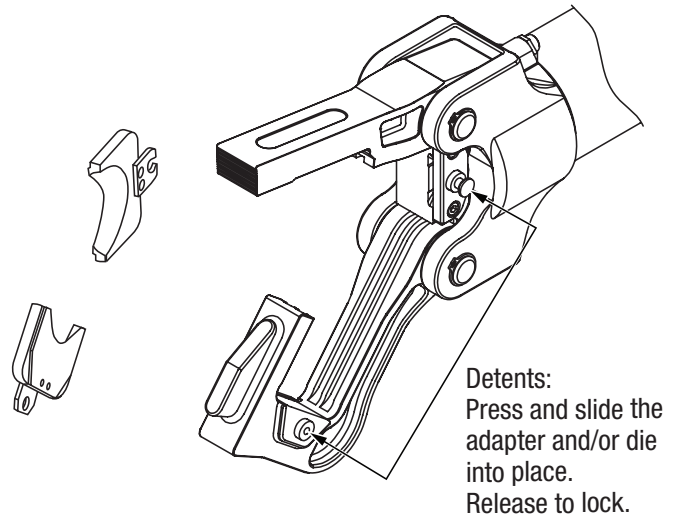

Cutting Procedure

1. Press the latch and open the tool head.
2. Position the item to be cut in the tool head.
3. Close the tool head.
4. Pull the trigger to cut the item.
5. Release the trigger when the cut is complete.
6. The ram returns automatically.



Operation – Punching

	⚠ WARNING
	<p>Electric shock hazard:</p> <p>Do not use this tool as a punch driver on or near live circuits. This includes, but is not limited to, the following circumstances:</p> <ul style="list-style-type: none"> • Energized electrical lines • Energized circuit breaker panels and fuse boxes • Junction boxes with energized circuits <p>Failure to observe this warning could result in severe injury or death.</p>

	⚠ WARNING
	<p>Wear eye protection when operating or servicing this tool.</p> <p>Failure to wear eye protection could result in serious eye injury from flying debris or hydraulic oil.</p>

	⚠ WARNING
	<p>Do not attempt to punch a hole through two or more thicknesses of material. This will bend or break the draw stud, and could throw parts with great force.</p> <p>Failure to observe this warning could result in severe injury or death.</p>

	⚠ WARNING
	<p>A component failure could throw broken parts.</p> <ul style="list-style-type: none"> • Do not allow anyone to stand in front of the punch. • Close access doors or covers on any equipment that is in line with the punch. <p>Failure to observe this warning could result in severe injury or death.</p>

⚠ WARNING
<p>Set up the tool properly. An improper setup could cause a component to fail and strike nearby personnel with great force.</p> <ul style="list-style-type: none"> • Thread the punch completely onto the draw stud. All of the punch threads must be engaged by the draw stud threads. Incomplete assembly could cause a component failure. • Use only Greenlee punches, dies, and draw studs. Other manufacturers' components might not withstand the forces generated by this punch driver. <p>Failure to observe these warnings could result in severe injury or death.</p>



Operation—Punching (cont'd)

Setup and Punching Procedure

1. Open the tool head.
2. Remove any accessories from the tool head.
3. Install the punch driver so that the drive piston is toward the yoke, as shown.

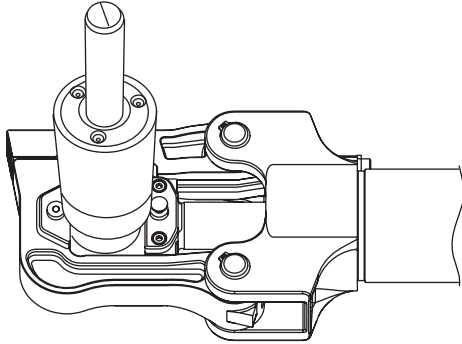

4. Close the tool head.
5. Select the punch, die, and draw stud to make the appropriate size hole. Refer to the illustrations on the following pages.
6. Determine and mark the exact location for the hole. Use a Greenlee Kwik Stepper® drill bit to drill a hole that is slightly larger than the draw stud. This is the pilot hole.
7. Push the retract button and hold the button until the ram is completely retracted.

8. Thread the 3/4" draw stud or 3/4" adapter completely into the punch driver. Refer to the illustrations on the following pages.

Notes: For a punch and die with a 3/8" center hole, thread the 3/8" draw stud into the end of the 3/4" adapter.

For 4" and larger punch and die, add the bushing to the die, slide the spacer over the 3/4" draw stud, and install the 1-1/8" sleeve.

9. Install a spacer, if necessary. Refer to the illustrations on the following pages.
10. Slide the die over the draw stud with the open end of the die facing away from the punch driver.
11. Insert the draw stud through the pilot hole.
12. Thread the punch onto the draw stud with the cutting surfaces of the punch facing the material. Tighten the punch by hand until the spacer, die, material, and punch contact each other.

Note: All of the punch threads must be engaged by the draw stud threads. If any of the punch threads are not engaged, disassemble the setup, remove the spacer, and reassemble the setup.

13. Pull the trigger.

Note: A "popping" sound indicates that the tool has reached relief pressure. This may indicate that the attempted operation is beyond the capacity of the tool.

14. Release the trigger when the punch completes the hole. The ram returns automatically.
15. Unscrew the punch. Remove slugs from the die. Remove the spacer and unscrew the draw stud.



Operation—Punching (cont'd)

Round Punches

Metric: 22.5 mm (max.)
Conduit Size: 1/2" (max.)
Actual Size: 0.885" (max.)

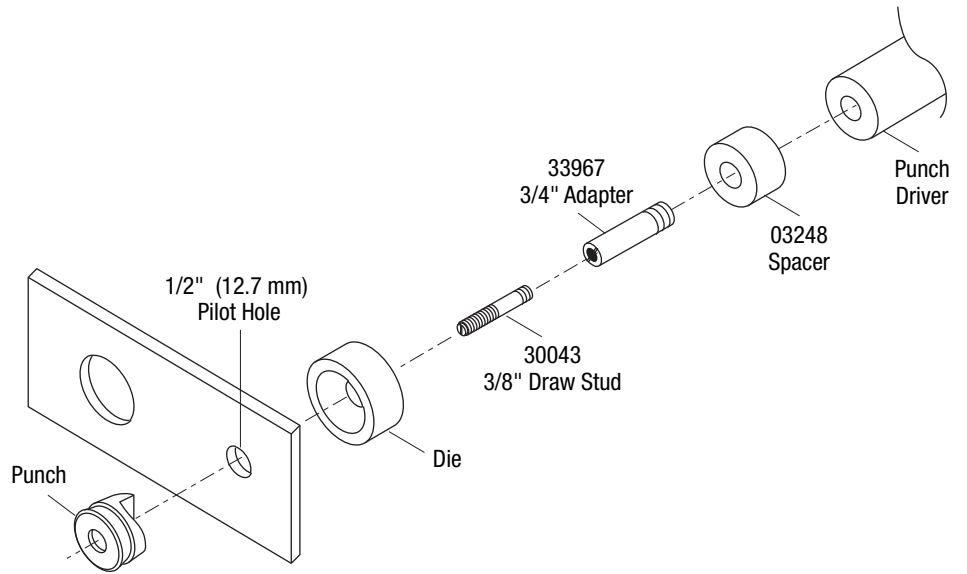

Round Punches

Metric: 28.3 mm to 95.2 mm
Conduit Size: 3/4" to 3"
Actual Size: 1.115" to 3.75"

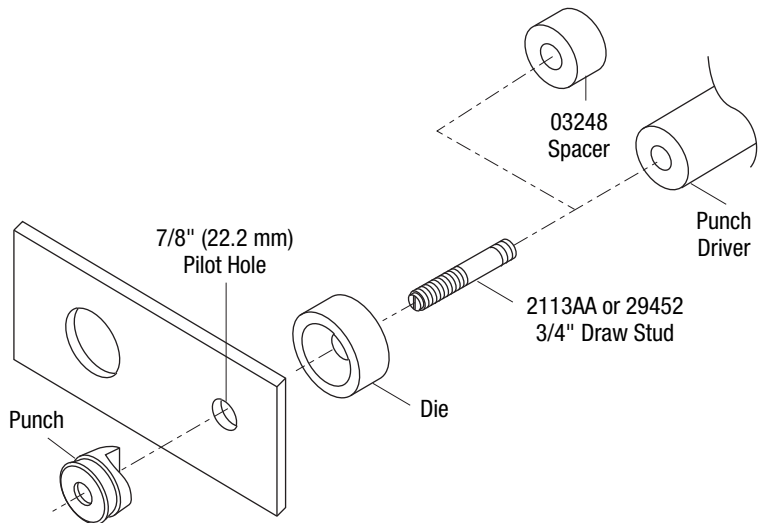

Round Punches

Metric: 95.2 mm to 143 mm
Conduit Size: 3-1/2" to 5"
Actual Size: 4" to 5-5/8"

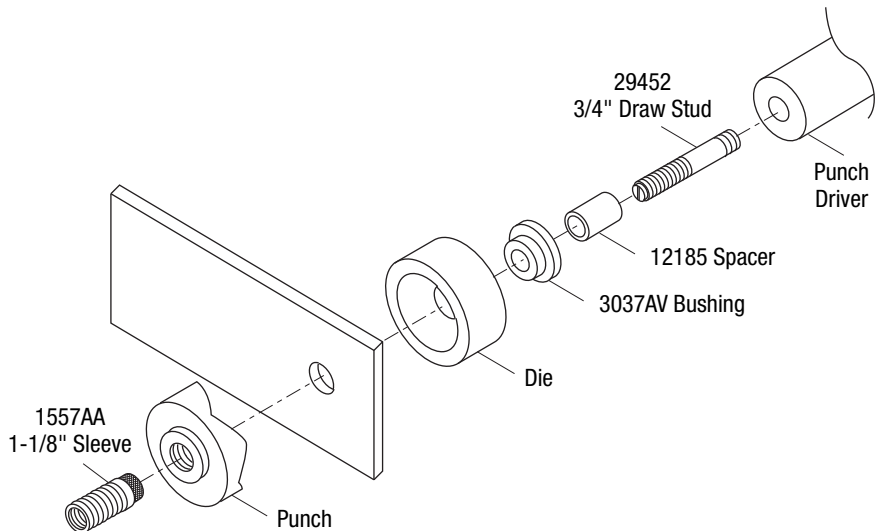



Operation—Punching (cont'd)

Square and Rectangular Punches

Metric: 12.7 mm square

Inches: 1/2" square

Metric: 11.1 mm x 22.2 mm rectangular

Inches: 7/16" x 7/8" rectangular

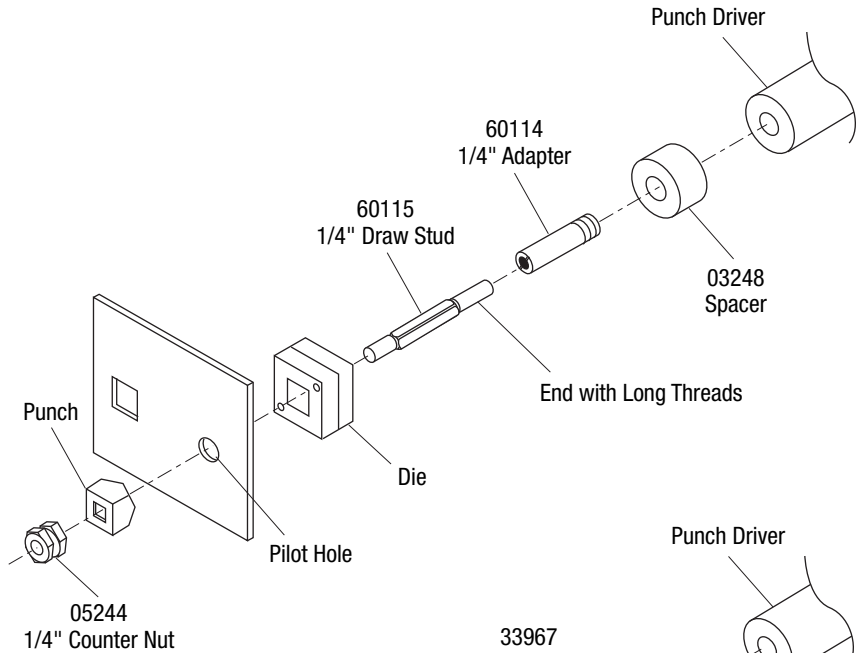

Square and Rectangular Punches

Metric: 15.9 mm to 24.0 mm square

Inches: 5/8" to 0.945" square

Metric: 17.0 mm x 19.0 mm rectangular

Inches: 0.670" x 0.749" rectangular

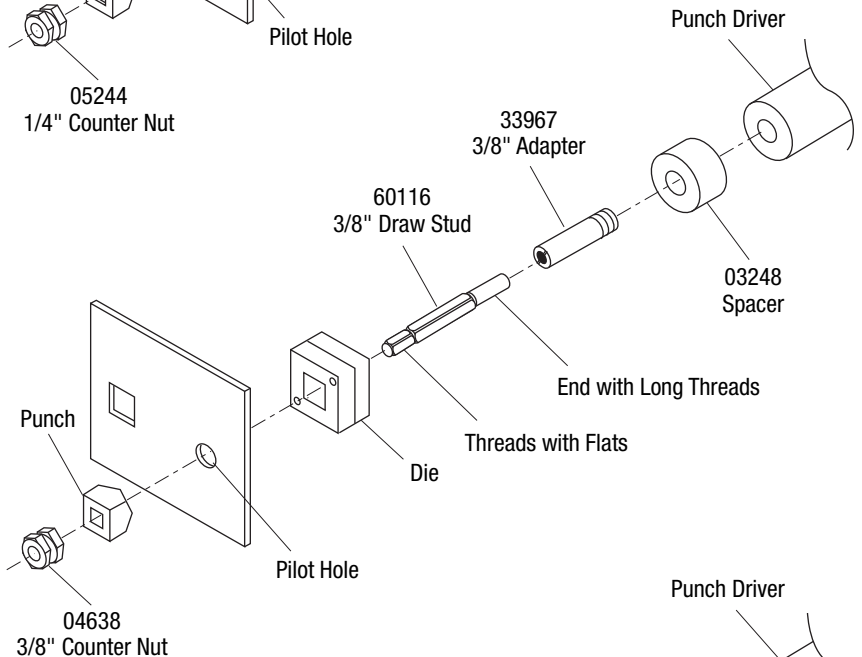

Square and Rectangular Punches

Metric: 25.4 mm square

Inches: 1" square

Metric: 19.1 mm x 29.0 mm to 31.8 mm x 35.1 mm rectangular

Inches: 0.750" x 1.140" to 1.250" x 1.380" rectangular

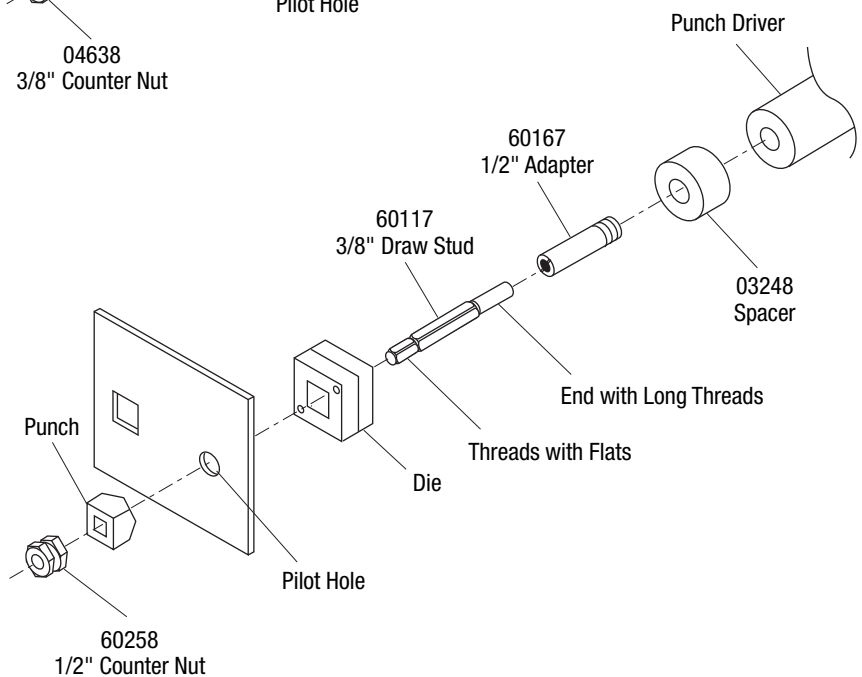



Operation—Punching (cont'd)

Square and Rectangular Punches

Metric: 46.0 mm to 68.0 square

Inches: 1.811" to 2.677" square

Metric: 33.3 mm x 66.7 mm to
35.0 mm x 65.0 mm rectangular

Inches: 1.312" x 2.625" to
1.378" x 2.559" rectangular

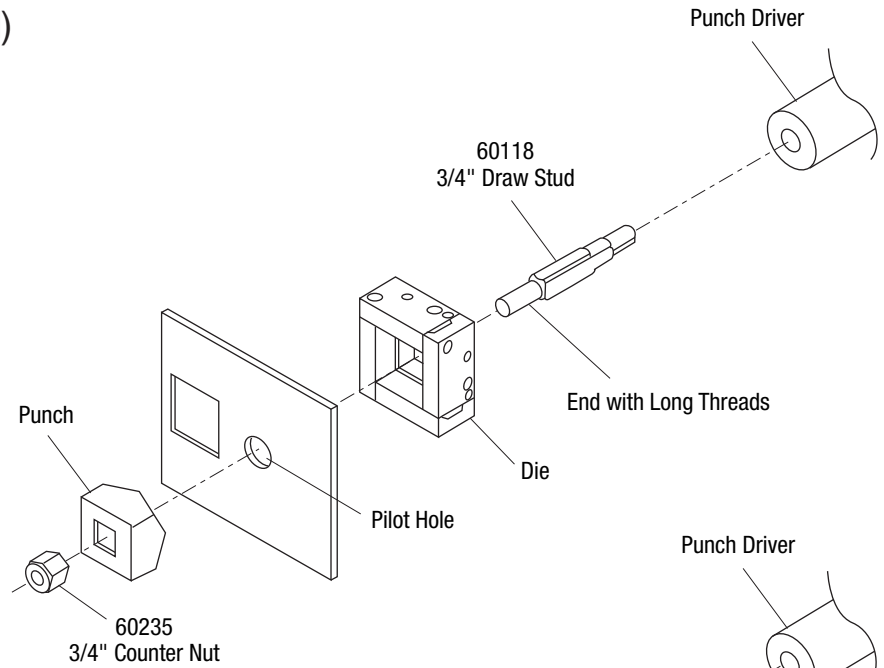

"D", Double "D", and Key Punches

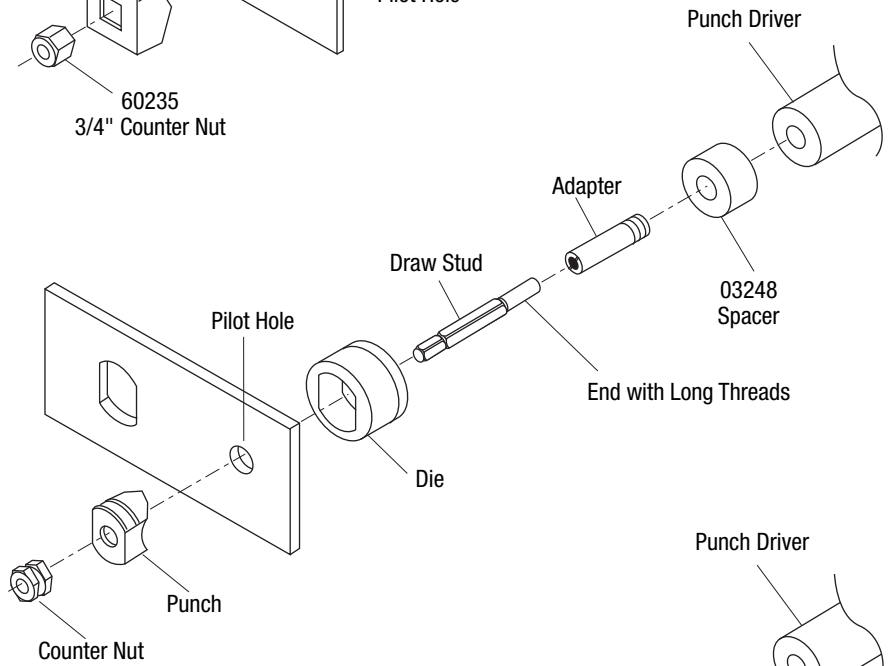

Electronic Connector Panel Punches

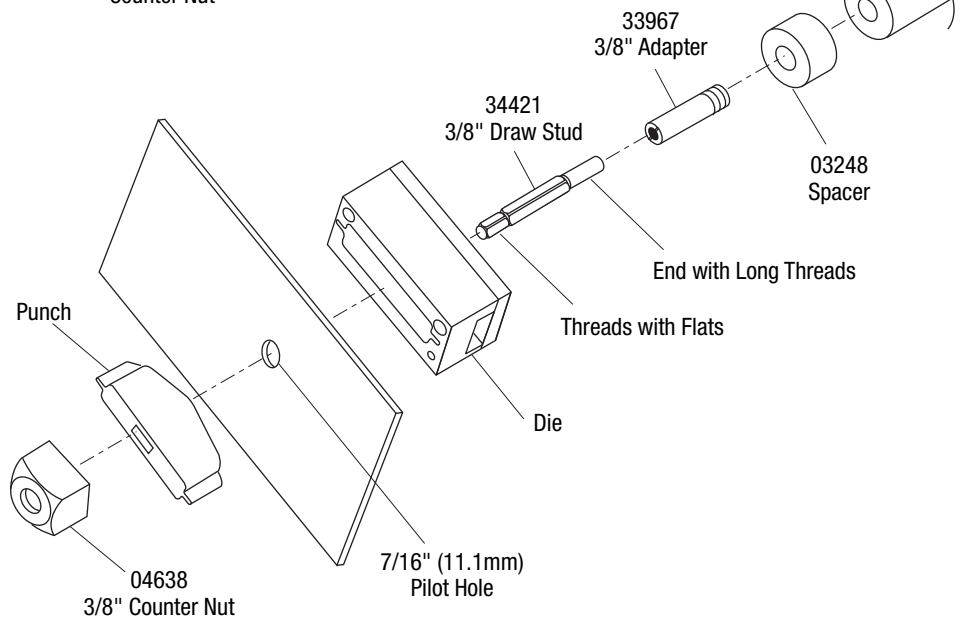



Die Selection

Refer to “Connector Selection” for brand names and model numbers of appropriate lugs as well as crimping instructions.

Crimps made with this tool and KC12-type or KA12-type dies are cUL and UL classified when used with the appropriate conductor and connectors listed below.

Dies for Copper Connectors

Catalog No.	UPC No.	Cable Size	Color Code	No. of Crimps
KC12-8	10996	8 AWG	Red	1
KC12-6	10997	6 AWG	Blue	1
KC12-4	10998	4 AWG	Gray	1
KC12-2	10999	2 AWG	Brown	1
KC12-1	11003	1 AWG	Green	1
KC12-1/0	11004	1/0 AWG	Pink	1
KC12-2/0	11007	2/0 AWG	Black	1
KC12-3/0	11010	3/0 AWG	Orange	1
KC12-4/0	11011	4/0 AWG	Purple	1
KC12-250	11012	250 kcmil	Yellow	1
KC12-300	11013	300 kcmil	White	2
KC12-350	11014	350 kcmil	Red	2
KC12-400	11015	400 kcmil	Blue	2
KC12-500	11016	500 kcmil	Brown	2
KC12-600	11018	600 kcmil	Green	2
KC12-750	11020	750 kcmil	Black	2

Dies for Aluminum Connectors

Catalog No.	UPC No.	Cable Size	Color Code	No. of Crimps
KA12-8	22084	8 AWG	Blue	1
KA12-6	22085	6 AWG	Gray	1
KA12-4	22086	4 AWG	Green	1
KA12-2	22087	2 AWG	Pink	1
KA12-1	22088	1 AWG	Gold	1
KA12-1/0	22089	1/0 AWG	Tan	1
KA12-2/0	22090	2/0 AWG	Olive	2
KA12-3/0	22121	3/0 AWG	Ruby	2
KA12-4/0	22122	4/0 AWG	White	2
KA12-250	22123	250 kcmil	Red	2
KA12-300	22124	300 kcmil	Blue	2
KA12-350	22125	350 kcmil	Brown	2
KA12-400	22126	400 kcmil	Green	3
KA12-500	22127	500 kcmil	Pink	3
KA12-600	22128	600 kcmil	Black	3
KA12-750	22129	750 kcmil	Yellow	3

Connector Selection (NOT for use with flex, navy or welding wire)

Tool Range: 8 AWG to 750 kcmil

When used with KC12-type dies, this tool is cUL and UL classified for use with the following connector brands:

CONNECTOR TYPE	BARREL TYPE	ANDERSON	BLACKBURN®	BURNDY	ILSCO	PANDUIT	T&B	PENN-UNION	NUMBER OF CRIMPS*
Copper Splices	Short	VHSS	CSP	YS-L	CT	SCSS SCS	54504 to 54523-TB	BCU	8 AWG to 250 kcmil: 1 crimp 300 to 750 kcmil: 2 crimps
	Long	VHS	CU	YS	CTL	SCL SCH	54804 to 54823	BBCU	
Copper Lugs	Short	VHCS	CTL-2/CTL	YA-2LN/ YA-L/YA-2L; YA/YA-L-TC/ YA-L-2TC	CSW CRA/CRB CRC	LCAS LCA LCD LCAN	54104 to 54123-TB; 54204 to 54223	BLU	
	Long	VHCL	CTL-L/LCN	YA/YAZ YA-2N/YA-2TC YAZ-2N/YAZ-2TC	CLN, CLW CRA-L/CRB-L CRA-2/CRB-2L CRC-2L	LCB LCC	54930BE to 54923BE; 54850BE to 54880BE	BBLU	

When used with KA12-type dies, this tool is cUL and UL classified for use with the following connector brands:

CONNECTOR TYPE	ANDERSON	BLACKBURN®	BURNDY	ILSCO	PANDUIT	T&B	PENN-UNION	NUMBER OF CRIMPS*
Dual-rated Aluminum Splices	VACS	ASP	YS-A	AS ASN	SA	60501 to 60578	PIK	8 to 1/0 AWG: 1 crimp 2/0 AWG to 350 kcmil: 2 crimps
Dual-rated Aluminum Lugs	VACL	ATL	YA-A YA-ATN	ACL/ACN 2ACL/2ACN ALNS/ALNN/ALND	LAA LAB	60101 to 60176; 60230 to 60278	BLUA	400 to 750 kcmil: 3 crimps



* Use the number of crimps listed in this column instead of the number provided with the connector.

**Additional U-type Dies**

Greenlee Catalog No.	Greenlee UPC No.	FCI Burndy No.
KD12-10	10188	U-BG
KD12-11	10189	U-0
KD12-12	10190	U-C
KD12-14	10192	U-161
KD12-15	10193	U-162
KD12-16	10194	U-163
KD12-17	10195	U-165
KD12-18	10196	U-166
KD12-19	10197	U-243
KD12-20	10198	U-247
KD12-21	10199	U-249
KD12-30	10200	U-D3
KD12-31	10201	U-E
KD12-32	10202	U-F
KD12-33	10203	U-997
KD12-35	10205	U-238
KD12-36	10206	U-654
KD12-37	10207	U-655
KD12-38	10208	U-658
KD12-39	10209	U-659
KD12-40	10210	U-998

Available Accessories

Adapter	Greenlee Part No.	Description
UC26	50067141	Cutter blades for copper and aluminum 26 mm (1") max.
UC40	50070363	Cutter blades for copper and aluminum 40 mm (1-1/2") max.
UCACSR	50070371	Cutter blades for ACSR, ACAR, standard guy wire, EHS guy wire, copperweld, ground rod, anchor rod, soft bolts, rebar
UCUNC14	50070380	Cutter blades for 1/4" threaded rod
UCUNC38	50070398	Cutter blades for 3/8" threaded rod
UCUNC12	50072749	Cutter blades for 1/2" threaded rod
UA12P	50118900	Punch driver adapter
04686	50046861	Die bushing*
12185	50121855	Spacer*
03170	50031708	Punch sleeve, 1-1/8"*
UA12T	52020102	Adapter for U-type dies
UA12ID	52061814	Dieless die set

*Required for knockout punches larger than 4" actual diameter.



cUL and UL Classified Crimps

Crimps made with the Greenlee UA12ID dieless die and E12CCXLT/X crimping tool are cUL and UL classified on standard concentric, compressed, or compact stranded copper and aluminum cable with the connectors listed here.

Refer to the “Connector Table” for the brand names and model numbers of appropriate connectors and the number of crimps required.

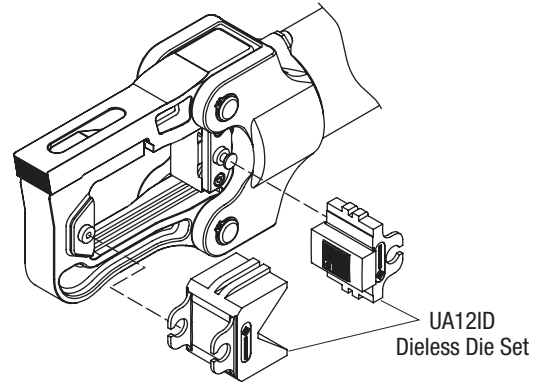

Connector Table (NOT for use with flex, navy or welding wire)

**Range: Copper Connectors—4 AWG to 750 kcmil
Aluminum Connectors—6 AWG to 600 kcmil**

COPPER CONNECTOR TYPE		ANDERSON	BLACKBURN®	BURNDY	ILSCO	PANDUIT	T & B	PENN-UNION	TYCO (AMP)
Copper Splices		VHSS VHS	CSP CU	YS-L YS	CT CTL	SCSS SCS SCL, SCH	54506 to 54528 54806 to 54828	BCU BBCU	—
Copper Lugs		VHCS VHCL	CTL CTL-L LCN	YA, YA-L, YA-2L YA-2LN, YA-2N YA-L-TC, YA-L-2TC YA-2TC, YAZ YAZ-2N, YAZ-2TC	CLN, CLW, CSW CRA, CRB, CRC CRA-L, CRB-L CRA-2L CRB-2L CRC-2L	LCAS LCA LCB LCD, LCC LCAN	54106 to 54128 54206 to 54228 54906BE to 54928BE 54854BE to 54882BE	BLU BBLU	1099898-2 to 1-1099898-5 1099899-2 to 1-1099899-9 1099939-1 to 1-1099939-5
*Number of Crimps	Copper Cable Size: 4 AWG–750 kcmil	1	1	1	1	1	1	1	1

ALUMINUM CONNECTOR TYPE		ANDERSON	BLACKBURN®	BURNDY	ILSCO	PANDUIT	T & B	PENN-UNION
Dual-Rated Aluminum Splices		VACS	ASP	YS-A	AS, ASN	SA	60507 to 60584	PIK BCUA
Dual-Rated Aluminum Lugs		VACL	ATL	YA-A YA-A-TN	ACL, ACN 2ACL, 2ACN ALNS, ALNN ALND	LAA LAB	60106 to 60184 60230 to 60284	BLUA
*Number of Crimps	Cable Size: 6 AWG–500 kcmil	1	1	1	1	1	1	1
	Cable Size: 600 kcmil	2	1	1	1	2	1	1

* When crimping with the UA12ID dieless die set, use the number of crimps listed in this table instead of the number provided with the connector.



LCD Screen

This tool has an LCD screen, which displays information about the tool. Turn on the screen by inserting the battery and jogging the tool. If there are any problems with the tool, an error code appears.

Error Code	Meaning
1	Overcurrent fuse
2	Overcurrent comparator
3	Overheated circuit board
4	Overheated battery
5	Battery empty; operation stops
6	Faulty crimp; complete cycle
7	Faulty crimp; incomplete cycle
8	Low battery
9	Battery empty; tool won't run
10	Real-time clock battery low
11	Tool deactivated
12	Service necessary
13	Real-time clock not found
14	Bluetooth® unit not found
15	Mobile unit not found
16	Pressure sensor not found
17	Burst pressure exceeded
18	Battery temperature too low

If there is no error code, cycle through the various displays using the left and right buttons on either side of the screen. There are seven displays in total.

Display	Information Shown
1	Bluetooth® status, battery charge, current pressure, max. pressure
2	Firmware, available firmware update, serial number
3	Current user. Press and hold both buttons to change user, select with right button, and confirm by jogging the tool.
4	GSM/CDMA signal strength
5	GPS signal status
6	Cycles until next service
7	Since manufacturing: operating hours, capacity, number of cycles

Note: Tool data transmission starts with production of the tool, independent of registration on i-connect, but only for the T version of this tool.



Maintenance

	⚠ WARNING
	<p>Wear eye protection when operating or servicing this tool.</p> <p>Failure to wear eye protection could result in serious eye injury from flying debris or hydraulic oil.</p>

	⚠ WARNING
	<p>Skin injection hazard:</p> <p>Do not use hands to check for oil leaks. Oil under pressure easily punctures skin. If injured, seek medical attention immediately to remove oil.</p> <p>Failure to observe this warning could result in serious injury, gangrene, or death.</p>

	⚠ WARNING
	<p>Do not use solvents or flammable liquids to clean the tool body. Solvents or flammable liquids could ignite and cause serious injury or property damage.</p>

	⚠ WARNING
	<p>Pinch points:</p> <ul style="list-style-type: none"> • Remove battery before changing dies, adapters, or jaws. • Keep hands away from the crimping tool head when crimping. <p>Failure to observe these warnings could result in severe injury or death.</p>

IMPORTANT
Relief valve adjustments must be done by an authorized service center.

Daily

Before use:

1. Inspect the tool for wear or damage, such as cracks, gouges, or chips.
2. Inspect the tool for damage or leaks.
3. Inspect the rotation of the head assembly. Fully retract the ram. The head should rotate no more than 360°. If damage is detected, contact Greenlee customer service at 800-435-0786 for warranty service or repair.

After use:

1. Use a damp cloth and mild detergent to clean the housing. Allow the housing to dry.
2. Fully retract the ram. Place the tool in the carrying case and store in a cool, dry place.
3. If necessary, recharge the batteries. Refer to the instructions supplied with the battery charger.

Monthly

Thoroughly clean all surfaces.

Annually or After 10,000 Crimps

Contact Greenlee customer service at 800-435-0786 for warranty service or repair, and hydraulic oil replacement.

Periodic Pressure Relief Valve Check

The crimping tool's relief valve may require occasional adjustment. To determine whether this adjustment is necessary, contact Greenlee customer service at 800-435-0786 for warranty service or repair.



Troubleshooting

Before You Begin

1. Make sure that the battery is charged. Recheck the battery after several minutes to make sure the battery is holding its charge.
2. Use a **nonflammable** contact cleaner or pencil eraser to clean the electrical contacts on the battery and tool.
3. Reinstall the battery and check the tool again.

Problem	Possible Cause	Probable Remedy
Tool is inoperative.	Battery charge low.	Charge or replace battery.
	Dirt, contaminants, etc., in ram area of tool.	Clean tool.
	Tool components worn or damaged.	Contact Greenlee customer service at 800-435-0786 for warranty service or repair.
Motor is inoperative.	Low or uncharged battery.	Try known charged battery. Inoperative battery may be discharged or may have reached life expectancy.
	Broken switch components.	Contact Greenlee customer service at 800-435-0786 for warranty service or repair.
Motor runs but tool will not complete a cycle.	Oil level low.	Contact Greenlee customer service at 800-435-0786 for warranty service or repair.
	Air in hydraulic system.	Pull trigger and hold retract button simultaneously. Run for approximately 10 seconds, and then attempt to crimp. If unsuccessful, contact Greenlee customer service at 800-435-0786 for warranty service or repair.
	Cold oil.	Pull trigger and hold retract button simultaneously to warm oil. Store tool in warm area.
Tool loses oil.	Damaged seal.	Contact Greenlee customer service at 800-435-0786 for warranty service or repair.



GREENLEE®

E12CCXLT and E12CCXLX 12-ton Battery-powered Tools





4455 Boeing Drive • Rockford, IL 61109-2988 • USA • 815-397-7070
An ISO 9001 Company • Greenlee Textron Inc. is a subsidiary of Textron Inc.

www.greenlee.com

USA Tel: 800-435-0786
Fax: 800-451-2632

Canada Tel: 800-435-0786
Fax: 800-524-2853

International Tel: +1-815-397-7070
Fax: +1-815-397-9247