

OPERATION MANUAL

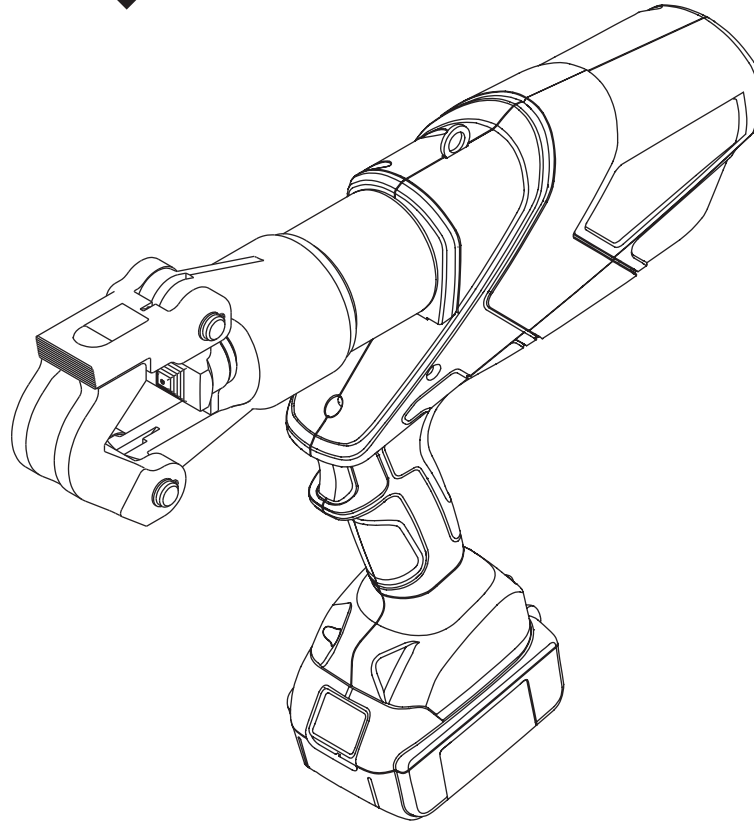

GREENLEE®
A Textron Company

Serial Number



EK12IDLT and EK12IDLX GATOR® Battery-powered, Dieless Crimping Tools



Read and understand all of the instructions and safety information in this manual before operating or servicing this tool.

Register this product at www.greenlee.com



Table of Contents

Description 2
 Safety 2
 Purpose of this Manual 2
 Important Safety Information 3–4
 Identification 5
 Specifications 5
 Operation 6–7
 Connector Selection 8
 LCD Screen 9
 Maintenance 10
 Troubleshooting 11

Description

The EK12IDLT and EK12IDLX Battery-powered, High-speed Crimping Tools are hand-held, self-contained, dieless crimping tools intended to crimp aluminum and copper connectors onto electrical cable.

These tools have a retraction stop feature which allows the operator to stop the retraction motion of the ram to shorten cycle time.

Both the T and X versions of this tool have Bluetooth® connectivity and an LCD screen. Only the T version has GPS tracking.

These tools are protected by U.S. Patent No. 6,206,663, 6,276,186, 6,401,515, and 6,718,870.

EK12IDLT – FCC ID: 2AGL2COM; IC ID: 20646COM
EK12IDLX – FCC ID: 2AGL2CFM; IC ID: 20646CFM

This device complies with Part 15 of the FCC Rules. Operation is subject to the following two conditions: (1) this device may not cause harmful interference, and (2) this device must accept any interference received, including interference that may cause undesired operation.

Safety

Safety is essential in the use and maintenance of Greenlee tools and equipment. This manual and any markings on the tool provide information for avoiding hazards and unsafe practices related to the use of this tool. Observe all of the safety information provided.

Purpose of this Manual

This manual is intended to familiarize all personnel with the safe operation and maintenance procedures for the following Greenlee tool:

- EK12IDLT Battery-powered, Dieless Crimping Tool
- EK12IDLX Battery-powered, Dieless Crimping Tool

Keep this manual available to all personnel.

Replacement manuals are available upon request at no charge at www.greenlee.com.



Do not discard this product or throw away!

For recycling information, go to www.greenlee.com.

All specifications are nominal and may change as design improvements occur. Greenlee Textron Inc. shall not be liable for damages resulting from misapplication or misuse of its products.

GATOR is a registered trademark of Textron Innovations Inc.

Bluetooth is a registered trademark of Bluetooth SIG, Inc.

Blackburn is a registered trademark of Thomas & Betts.

KEEP THIS MANUAL



IMPORTANT SAFETY INFORMATION



SAFETY ALERT SYMBOL

This symbol is used to call your attention to hazards or unsafe practices which could result in an injury or property damage. The signal word, defined below, indicates the severity of the hazard. The message after the signal word provides information for preventing or avoiding the hazard.

⚠ DANGER

Immediate hazards which, if not avoided, **WILL** result in severe injury or death.

⚠ WARNING

Hazards which, if not avoided, **COULD** result in severe injury or death.

⚠ CAUTION

Hazards or unsafe practices which, if not avoided, **MAY** result in injury or property damage.

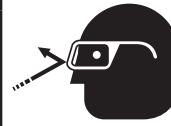

⚠ WARNING

Wear eye protection when operating or servicing this tool.

Failure to wear eye protection could result in serious eye injury from flying debris or hydraulic oil.



⚠ WARNING

Skin injection hazard:

Do not use hands to check for oil leaks. Oil under pressure easily punctures skin. If injured, seek medical attention immediately to remove oil.

Failure to observe this warning could result in serious injury, gangrene, or death.



⚠ WARNING

Do not use solvents or flammable liquids to clean the tool body. Solvents or flammable liquids could ignite and cause serious injury or property damage.



⚠ WARNING

Read and understand all of the instructions and safety information in this manual before operating or servicing this tool.

Failure to observe this warning could result in severe injury or death.



⚠ WARNING

Electric shock hazard:

This tool is not insulated. When using this unit on or near energized electrical lines, use proper personal protective equipment.

Failure to observe this warning could result in severe injury or death.

⚠ WARNING

An incomplete crimp can cause a fire.

- Use proper die, connector, and cable combinations. Improper combinations can result in an incomplete crimp.
- The relief valve sounds and the ram automatically retracts to indicate a completed crimp. If you do not hear the sound of the relieve valve or the ram does not automatically retract, the crimp is not complete.

Failure to observe these warnings could result in severe injury or death.



⚠ WARNING

Pinch points:

- Remove battery before changing dies, adapters, or jaws.
- Keep hands away from the crimping tool head when crimping.

Failure to observe these warnings could result in severe injury or death.



IMPORTANT SAFETY INFORMATION

⚠ WARNING

Do not dispose of batteries in a fire. They will vent fumes and may explode.

Failure to observe this warning could result in severe injury from harmful fumes or burns from flying debris.

⚠ WARNING

Remove the battery before transporting the T version of this tool by air.

Failure to observe this warning could result in severe injury or death.

⚠ WARNING

- Inspect tool and dies before use. Replace any worn or damaged parts. A damaged or improperly assembled tool can break and strike nearby personnel.
- Carrying strap is for carrying only, not to be used to hang or suspend tool.

Failure to observe these warnings could result in severe injury or death.

⚠ CAUTION

- Do not use this tool for continuous use. After 30 to 40 cycles, allow the tool to cool for 15 minutes.
- Do not secure this tool in a vise. This tool is designed for hand-held operation.
- This tool may be used in damp or wet environments; however, air-drying is recommended before use if the tool becomes soaked. Damage may result when the tool is operated prior to thorough drying when electrical components are soaked.
- Use this tool for the manufacturer's intended purpose only.

Failure to observe these precautions may result in injury or property damage.

⚠ CAUTION

Do not allow anything to contact the battery terminals.

- Do not immerse the batteries in liquid. Liquid may create a short circuit and damage the battery. If batteries are immersed, contact your service center for proper handling.
- Do not place the battery into a pocket, tool pouch, or tool box with conductive objects. Conductive objects may create a short circuit and damage the battery.
- Do not place a battery on moist ground or grass. Moisture may create a short circuit and damage the battery.

Failure to observe these precautions may result in injury or property damage.

⚠ CAUTION

- Do not store the battery at more than 122 °F (50 °C) or less than -4 °F (-20 °C). Damage to the battery can result.
- Do not use another manufacturer's charger. Other manufacturers' chargers may overcharge and damage the battery.
- Do not attempt to open the battery. It contains no user-serviceable parts.

Failure to observe these precautions may result in injury or property damage.

⚠ CAUTION

Do not perform any service or maintenance other than as described in this manual. Injury or damage to the tool may result.

Failure to observe this precaution may result in injury and property damage.

Note: Keep all decals clean and legible, and replace when necessary.



Identification

- 1. LED Work Light (white)
- 2. Indenter
- 3. Head
- 4. Latch (for opening head)
- 5. Lanyard Ring
- 6. Housing
- 7. Retract Button
- 8. LED Indicator (red)
- 9. LCD Screen
- 10. Battery
- 11. Trigger

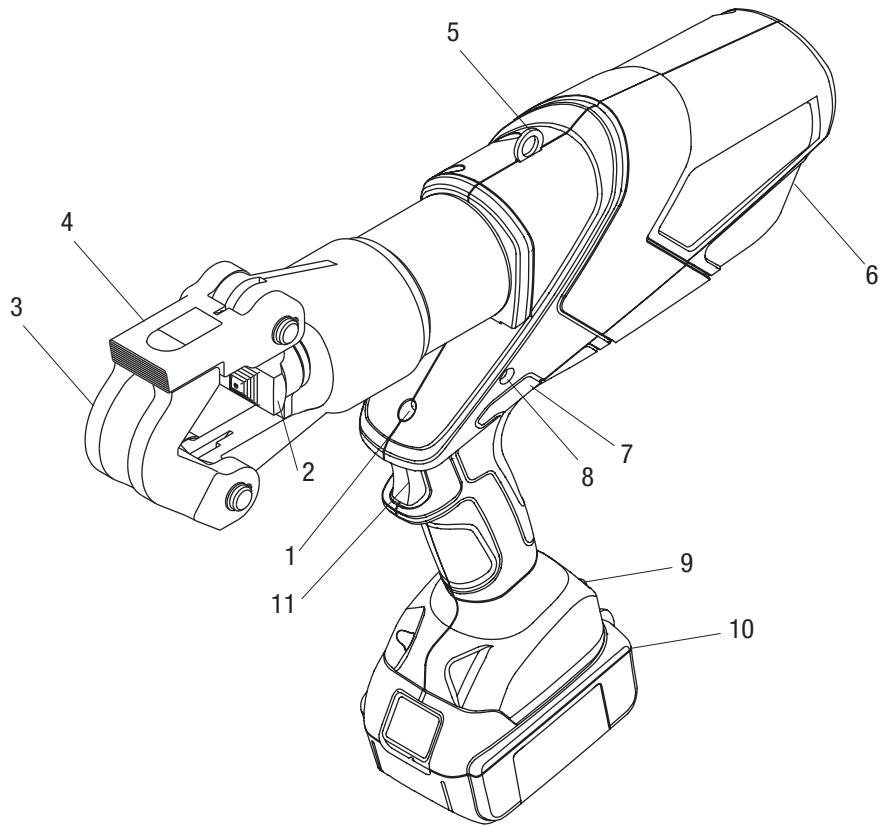

Specifications

Crimping Tool

Length	17.2" (437 mm)
Width	3.00" (76 mm)
Height (with battery)	13.4" (340 mm)
Weight	15 lb (6.8 kg)
Crimping Force.....	12 tons (106 kN)
Hydraulic Oil.....	52057878 biodegradable hydraulic fluid
Recommended Operating Temperature Range.....	5 °F to 122 °F (-15 °C to 50 °C)

Crimping Capacities

Crimping Range

Aluminum	6 AWG to 1000 kcmil
Copper	4 AWG to 1000 kcmil
Battery Charger	Read the instructions supplied with the battery charger



Operation

⚠ WARNING

- Inspect tool and dies before use. Replace any worn or damaged parts. A damaged or improperly assembled tool can break and strike nearby personnel.
- Carrying strap is for carrying only, not to be used to hang or suspend tool.

Failure to observe these warnings could result in severe injury or death.

⚠ CAUTION

- Do not use this tool for continuous use. After 30 to 40 cycles, allow the tool to cool for 15 minutes.
- Do not secure this tool in a vise. This tool is designed for hand-held operation.
- This tool may be used in damp or wet environments; however, air-drying is recommended before use if the tool becomes soaked. Damage may result when the tool is operated prior to thorough drying when electrical components are soaked.
- Use this tool for the manufacturer's intended purpose only.

Failure to observe these precautions may result in injury or property damage.



⚠ WARNING

Electric shock hazard:

This tool is not insulated. When using this unit on or near energized electrical lines, use proper personal protective equipment.

Failure to observe this warning could result in severe injury or death.

Charging the Battery

Read the instructions supplied with the battery charger.

LED Work Light (white)

This LED automatically turns on when the trigger is pulled. It remains on for 10 seconds after the trigger is released.

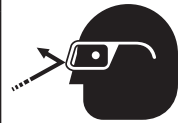

⚠ WARNING

Wear eye protection when operating or servicing this tool.

Failure to wear eye protection could result in serious eye injury from flying debris or hydraulic oil.

LED Indicator (red)

This tool is equipped with a special circuit board incorporating several important features to inform the user about the current status of the unit. The LED signals in the following cases:



⚠ WARNING

Pinch points:

- Remove battery before changing dies, adapters, or jaws.
- Keep hands away from the crimping tool head when crimping.

Failure to observe these warnings could result in severe injury or death.

What happens	Signal	What it means
Constant light for 20 seconds at end of cycle	█	Battery charge is below 17 V at beginning of cycle*
Tool will not start, and constant light for 20 seconds when trigger is released	█	Battery charge is below 16 V at beginning of cycle*
Tool will stop, and constant light for 20 seconds after trigger is released	█	Battery voltage drops below 13 V during cycle*
Tool will stop, and flashing light for 20 seconds when trigger is released	●●●●	Motor current exceeds 20 A during cycle Circuit has become too hot
Flashing light for 20 seconds at end of cycle	●●●●	Send tool in for service

* Running the battery below 16 V can damage the battery.



Operation (cont'd)

Pressure Sensor

This tool is equipped with a pressure sensor that alerts the user of an incomplete crimp.

- If the tool is manually retracted before completion of a crimp, the red LED and an audible beep will be active for 2 seconds.
- If the tool is unable to reach the required crimp force, the red LED, work light, and an audible beep will pulse until after the trigger is released.

Preparation

IMPORTANT

For a cUL or UL classified crimp, refer to the "Connector Table" in this instruction manual.

1. Select a proper size and type of connector to correspond with the wire or cable.
2. Strip the cable to an appropriate length. Follow the connector manufacturer's instructions.

Note: Apply an oxide inhibitor, if required. Refer to the connector manufacturer's instructions.

Crimping

1. Insert the cable fully into the connector.
2. Place the connector into the V of the crimping head, as shown below.

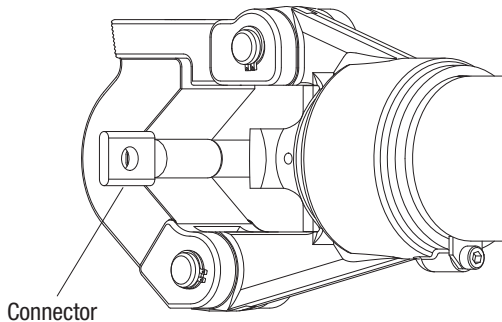

3. If open, close the crimping head. Make sure the head and latch are fully engaged.
4. For a cUL or UL classified crimp, complete the number of crimps specified in the "Connector Table" in this manual.
5. For a single crimp, position the connector so the crimp will be located at the center of the barrel. For a double crimp, position the connector so two crimps will be evenly spaced between the connector marks.

6. Depress the trigger to advance the indenter. Hold the trigger down until the indenter automatically begins to retract.

Note: If the crimping tool does not automatically retract, the crimp is incomplete.

It is normal for the battery load display to light at both the beginning and near the end of the crimping cycle.

7. Release the trigger until the indenter retracts completely.
8. To stop the ram from returning fully, activate the trigger for a brief moment. This activation will close the retraction valve and stop the retraction motion.
9. Lift the latch to open the crimping head and remove the connector.

Note: If it is necessary to retract the indenter before a crimp cycle is complete, push the retract button. Pushing the retract button will result in complete retraction of the indenter.

After completing the last crimp on an aluminum connector, wipe off the excess oxide inhibitor.

⚠ WARNING

An incomplete crimp can cause a fire.

- Use proper die, connector, and cable combinations. Improper combinations can result in an incomplete crimp.
- The relief valve sounds and the ram automatically retracts to indicate a completed crimp. If you do not hear the sound of the relieve valve or the ram does not automatically retract, the crimp is not complete.

Failure to observe these warnings could result in severe injury or death.

Automatic Retraction Stop

1. Depress the trigger to advance the indenter. Hold the trigger down until the indenter automatically retracts. The indenter will partially retract to allow the tool to be repositioned.
2. If full retraction is desired, release the trigger at the end of the crimp.



cUL and UL Classified Crimps

Crimps made with the Greenlee EK12IDLT/X Dieless Crimping Tool are cUL and UL classified on standard concentric, compressed, or compact stranded copper and aluminum cable with the connectors listed here.

Refer to the “Connector Table” for the brand names and model numbers of appropriate connectors and the number of crimps required.

Connector Table

(NOT for use with flex, navy or welding wire)

Copper Connector Type		Anderson	Blackburn®	Burndy	ILSCO	Panduit	T & B	Penn-Union	Tyco (AMP)
Copper Splices		VHSS VHS	CSP CU	YS-L YS	CT CTL	SCSS SCS SCL, SCH	54506 to 54528 54806 to 54828	BCU BBCU	—
Copper Lugs		VHCS VHCL	CTL CTL-L LCN	YA, YA-L, YA-2L YA-2LN, YA-2N YA-L-TC, YA-L-2TC YA-2TC, YAZ YAZ-2N, YAZ-2TC	CLN, CLW, CSW CRA, CRB, CRC CRA-L, CRB-L CRA-2L CRB-2L CRC-2L	LCAS LCA LCB LCD, LCC LCAN	54106 to 54128 54206 to 54228 54906BE to 54928BE 54854BE to 54882BE	BLU BBLU	1099898-2 to 1-1099898-5 1099899-2 to 1-1099899-9 1099939-1 to 1-1099939-5
*Number of Crimps	Copper Cable Size: 4 AWG–1000 kcmil	1	1	1	1	1	1	1	1

Aluminum Connector Type		Anderson	Blackburn®	Burndy	ILSCO	Panduit	T & B	Penn-Union
Dual-Rated Aluminum Splices		VACS	ASP	YS-A	AS ASN	SA	60507 to 60584	PIK BCUA
Dual-Rated Aluminum Lugs		VACL	ATL	YA-A YA-A-TN	ACL, ACN 2ACL, 2ACN ALNS, ALNN, ALND	LAA LAB	60106 to 60184 60230 to 60284	BLUA
*Number of Crimps	Cable Size: 6 AWG–500 kcmil	1	1	1	1	1	1	1
	Cable Size: 600 kcmil–800 kcmil	2	1	1	1	2	1	1
	Cable Size: 1000 kcmil	2	2	2	2	2	2	2

* When crimping with the EK12IDLL crimping tool, use the number of crimps listed in this table instead of the number provided with the connector.



LCD Screen

This tool has an LCD screen, which displays information about the tool. Turn on the screen by inserting the battery and jogging the tool. If there are any problems with the tool, an error code appears.

If there is no error code, cycle through the various displays using the left and right buttons on either side of the screen. There are seven displays in total.

Error Code	Meaning
1	Overcurrent fuse
2	Overcurrent comparator
3	Overheated circuit board
4	Overheated battery
5	Battery empty; operation stops
6	Faulty crimp; complete cycle
7	Faulty crimp; incomplete cycle
8	Low battery
9	Battery empty; tool won't run
10	Real-time clock battery low
11	Tool deactivated
12	Service necessary
13	Real-time clock not found
14	Bluetooth® unit not found
15	Mobile unit not found
16	Pressure sensor not found
17	Burst pressure exceeded
18	Battery temperature too low

Display	Information Shown
1	Bluetooth® status, battery charge, current pressure, max. pressure
2	Firmware, available firmware update, serial number
3	Current user. Press and hold both buttons to change user, select with right button, and confirm by jogging the tool.
4	GSM/CDMA signal strength
5	GPS signal status
6	Cycles until next service
7	Since manufacturing: operating hours, capacity, number of cycles

Note: Tool data transmission starts with production of the tool, independent of registration on i-connect, but only for the T version of this tool.



Maintenance

	⚠ WARNING
	<p>Wear eye protection when operating or servicing this tool.</p> <p>Failure to wear eye protection could result in serious eye injury from flying debris or hydraulic oil.</p>

	⚠ WARNING
	<p>Skin injection hazard:</p> <p>Do not use hands to check for oil leaks. Oil under pressure easily punctures skin. If injured, seek medical attention immediately to remove oil.</p> <p>Failure to observe this warning could result in serious injury, gangrene, or death.</p>

	⚠ WARNING
	<p>Do not use solvents or flammable liquids to clean the tool body. Solvents or flammable liquids could ignite and cause serious injury or property damage.</p>

	⚠ WARNING
	<p>Pinch points:</p> <ul style="list-style-type: none"> • Remove battery before changing dies, adapters, or jaws. • Keep hands away from the crimping tool head when crimping. <p>Failure to observe these warnings could result in severe injury or death.</p>

IMPORTANT
Relief valve adjustments must be done by an authorized service center.

Daily

Before use:

1. Inspect the tool for wear or damage, such as cracks, gouges, or chips.
2. Inspect the tool for damage or leaks.
3. Inspect the rotation of the head assembly. Fully retract the ram. The head should rotate no more than 360°. If damage is detected, contact Greenlee customer service at 800-435-0786 for warranty service or repair.

After use:

1. Use a damp cloth and mild detergent to clean the housing. Allow the housing to dry.
2. Fully retract the ram. Place the tool in the carrying case and store in a cool, dry place.
3. If necessary, recharge the batteries. Refer to the instructions supplied with the battery charger.

Monthly

Thoroughly clean all surfaces.

Annually or After 10,000 Crimps

Contact Greenlee customer service at 800-435-0786 for warranty service or repair, and hydraulic oil replacement.



Troubleshooting

Before You Begin

1. Make sure that the battery is charged. Recheck the battery after several minutes to make sure the battery is holding its charge.
2. Use a **nonflammable** contact cleaner or pencil eraser to clean the electrical contacts on the battery and tool.
3. Reinstall the battery and check the tool again.

Problem	Possible Cause	Probable Remedy
Tool is inoperative.	Battery charge low.	Charge or replace battery.
	Dirt, contaminants, etc., in ram area of tool.	Clean tool.
	Tool components worn or damaged.	Contact Greenlee customer service at 800-435-0786 for warranty service or repair.
Motor is inoperative.	Low or uncharged battery.	Try known charged battery. Inoperative battery may be discharged or may have reached life expectancy.
	Broken switch components.	Contact Greenlee customer service at 800-435-0786 for warranty service or repair.
Motor runs but tool will not complete a cycle.	Oil level low.	Contact Greenlee customer service at 800-435-0786 for warranty service or repair.
	Air in hydraulic system.	Pull trigger and hold retract button simultaneously. Run for approximately 10 seconds, and then attempt to crimp. If unsuccessful, contact Greenlee customer service at 800-435-0786 for warranty service or repair.
	Cold oil.	Pull trigger and hold retract button simultaneously to warm oil. Store tool in warm area.
Tool loses oil.	Damaged seal.	Contact Greenlee customer service at 800-435-0786 for warranty service or repair.



4455 Boeing Drive • Rockford, IL 61109-2988 • USA • 815-397-7070
An ISO 9001 Company • Greenlee Textron Inc. is a subsidiary of Textron Inc.

www.greenlee.com

USA Tel: 800-435-0786
Fax: 800-451-2632

Canada Tel: 800-435-0786
Fax: 800-524-2853

International Tel: +1-815-397-7070
Fax: +1-815-397-9247