

High Performance Ground Fault Sensing for Automation Applications

Ground Fault Sensors

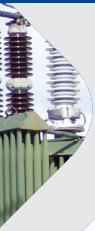

C

Application Guide

www.nktechnologies.com

800.959.4014



A Company Built Upon A History Of Innovation

Seeing the need for an economical way to measure current draw, Maynard Kuljian founded Neisen-Kuljian, Inc. in 1982 becoming the first to develop the low-cost solid-state current sensing technology that underlies the industry today. True to this heritage, NK Technologies continues to focus on developing and manufacturing innovative, cost-effective current sensing products designed to add value that meet or exceed customer's performance expectations. With a portfolio of over 1300 models, NK Technologies remains a leading supplier of current measurement solutions to the industrial and factory automation markets. As the needs of these markets change, NK Technologies - a company built upon a history of innovation - is well-positioned to respond with sophisticated new product designs and improved product functionality necessary to meet those applications. Our goal is to make our customers successful!

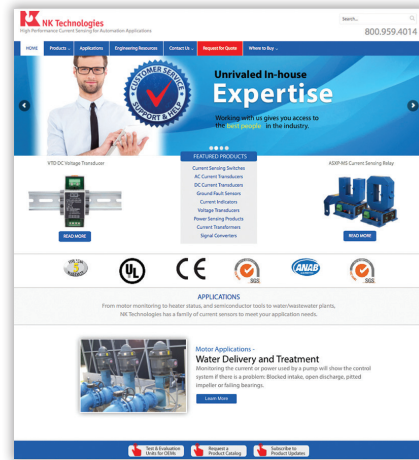

NK Technologies takes its commitment to customers seriously and considers customer satisfaction a top priority, offering:

- Timely response to customer inquiries
- Knowledgeable technical support
- A willingness to develop custom solutions to meet specific customer needs
- Organizational commitment to delivering reliable, quality product
 - On time delivery to meet customer production needs

NK Technologies provides best-suited product selection and excellent application solutions, including:

- A wide portfolio of high-quality products designed and manufactured in the USA
- Personalized engineering assistance located in the heart of Silicon Valley
- RoHS, UL and CE compliant products
- ISO9001:2015 and ISO14001:2015 certifications
- Industry best 5 Year product warranty

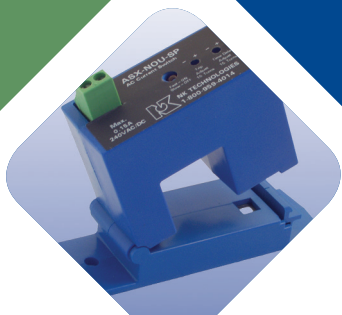
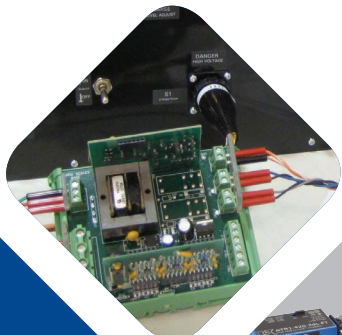

Table of Contents

Ground Fault Detection Considerations

- What is a Ground Fault?
- Why is Detecting Ground Faults Important?
- What is a Ground Fault Sensor?
- How to Choose the Right Ground Fault Sensor Solution
- Why Choose NK Technologies as Your Supplier?
- What NK Technologies Products Address Ground Faults?

Ground Fault Sensors Selection Chart

Solutions for Industry

Wet Environments

- Agriculture and Aquaculture
- Biotech and Biopharma
- Chemical Processing
- Food/Beverage, Bottling/Canning
- Fountains
- Marinas
- Material Reduction, Shredders and Grinders
- Oil and Gas
- Pharmaceuticals
- Water and Wastewater

Electrical Heating Systems

- Extrusion
- Furnaces and Kilns
- Manufacturing
- Semiconductors
- Commercial Kitchens
- Snow Melt

General Equipment Protection

- Entertainment
- Petrochemicals
- Refrigeration and Compressors
- Timber and Logging
- Utilities and Power Generation

Ground Fault Detection for High Current Circuits at Marina Docking Facilities

Adjustable Ground Fault Detection for Commercial Kitchens

Ground Fault Detection in Semiconductor Fabrication Equipment

Detecting DC Current Leakage to Earth

Electrical Heating System Protection

Preventative Maintenance Using Ground Fault Monitors

Ground Fault Sensing Basics

Dangers of Electricity Discovered

Earth Fault Detection Requirements

- Protecting People
- Protecting Processes
- Detection Methods



Ground Fault Detection Considerations

What is a Ground Fault?

Ground faults occur when current flows from an energized conductor to ground, which can energize other equipment and potentially cause harm if touched. Ground fault detection is critical to protect people and animals from being shocked or killed. NK Technologies, a leading supplier of current sensing and power monitoring products, offers a broad selection of ground fault sensors used to prevent harm to personnel, equipment, and processes.

Why is Detecting Ground Faults Important?

Ground faults can be costly if not checked. They can cause a fire to erupt, create equipment damage, or even shock or electrocute personnel. Numerous safety regulations and electrical codes exist to prevent and protect against ground faults.

What is a Ground Fault Sensor?

Ground fault sensors consist of a single magnetically permeable toroid surrounding current carrying conductors connected to an electrical device such as a motor, heater element, pump, or other machinery. The current transformer detects any imbalance through the conductors measuring current leakage to ground. The ground fault sensor may then trigger a contactor to disconnect power or to send an alarm to a higher-level control that initiates the appropriate action.

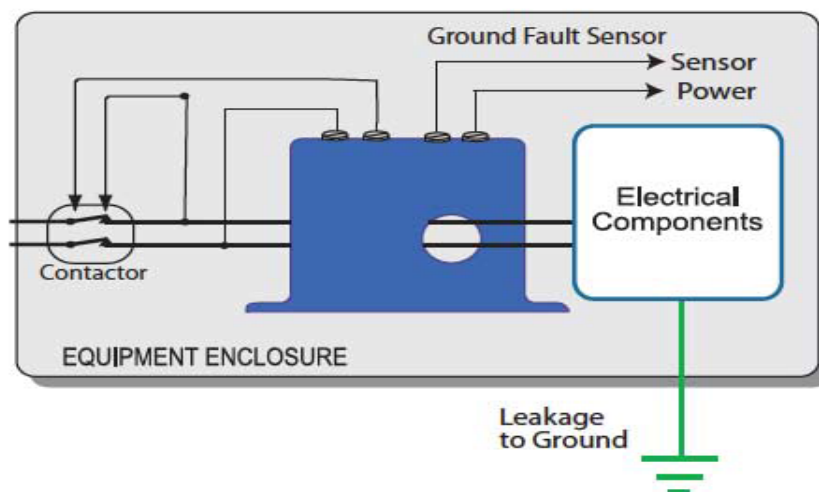

How to Choose the Right Ground Fault Sensor Solution

The size of conductors, set points, and subsequent actions if a ground fault is detected all need to be considered. What do the local codes require for protection and disconnect? What is the main goal in setting up a ground fault device? Is it focused on personnel protection or electrical device/process protection?

Why Choose NK Technologies as Your Supplier?

With over 1300 different product designs, NK Technologies continues to be a leader in current sensing technologies in the industrial and automation markets. The San Jose, CA based team is available to help solve your ground fault detection needs with reliable and innovative solutions. NK Technologies stand behind their products with an industry leading 5 year warranty.



What NK Technologies Products Address Ground Faults?

NK Technologies supplies a variety of current sensing components including a line of ground fault sensor products to address various application needs. Available ground fault sensors can provide monitoring of ground leakage current, sensors with fixed setpoints, and sensors that enable adjustable setpoints and delays.



Ground Fault Sensors Selection Chart

Series	Aperture Size	Outputs	Setpoint	Power Supply	Response Time
Sensors Ideal for Monitoring Ground Fault Currents					
AGT 	0.74 in. (19 mm)	4 – 20 mA, loop powered, true RMS	Analog output proportional to current	24 VDC	600 ms @ 90% step change
AGT-FD 	1.3 in. (33.3 mm)	Analog signal: 0 – 5 VDC or 0 – 10 VDC proportional to 100mA	Analog output proportional to current	24 VAC/DC	250 ms @ 90% step change
Sensors with Fixed Setpoints					
AG 	0.74 in. (19 mm)	Solid State Switch 1A@240 VAC or 0.15A@30 VDC Electromechanical Relay Auto reset SPDT: 1A@125 VAC or 2A@30 VDC Latching SPST: 1A@125 VAC or 2A@30 VDC	Factory Calibrated: AG1: 5 – 100 mA AG2: 80 – 950 mA	120 VAC or 24 VAC/DC	200 ms @ 5% over set point 60 ms @ 50% 15 ms @500%
DG 	0.74 in. (19 mm)	Electromechanical Relay Auto reset SPDT: 1A@125 VAC or 2A@30 VDC Latching SPST: 1A@125 VAC or 2A@30 VDC	Factory set 5 – 50 mA	24 VDC	55 ms maximum
AGL 	1.875 in. (46.2 mm)	Electromechanical Relay Auto reset SPDT: 1A@125 VAC or 2A@30 VDC Latching SPST: 1A@125 VAC or 2A@30 VDC	Factory Calibrated: AGL1: 5 – 100 mA AGL2: 80 – 950 mA	120 VAC or 24 VAC/DC	200 ms @ 5% 60 ms @ 50% 15 ms @500%
AG-LC	4.0 in. (101.6 mm)	Electromechanical Relay Auto reset SPDT: 1A@125 VAC or 2A@30 VDC Latching SPST: 1A@125 VAC or 2A@30 VDC	Factory Set Point AGC: 30 – 150 mA AGD: 80 – 400 mA Adjustable delay 0.1 – 8.0 sec	120 VAC or 24 VAC/DC	100 ms @90% over set point

Series	Aperture Size	Outputs	Setpoint	Power Supply	Response Time
Sensors with Fixed Setpoints					
AG 	0.74 in. (19 mm)	Solid State Switch 1A@240 VAC or 0.15A@30 VDC Electromechanical Relay Auto reset SPDT: 1A@125 VAC or 2A@30 VDC Latching SPST: 1A@125 VAC or 2A@30 VDC	Factory Calibrated: AG1: 5 – 100 mA AG2: 80 – 950 mA	120 VAC or 24 VAC/DC	200 ms @ 5% 60 ms @ 50% 15 ms @500%
AGL 	1.875 in. (46.2 mm)	Electromechanical Relay Auto reset SPDT: 1A@125 VAC or 2A@30 VDC Latching SPST: 1A@125 VAC or 2A@30 VDC	Tri-Set Field Jumper Selectable (5, 10, or 30 mA)	120 VAC or 24 VAC/DC	200 ms @ 5% 60 ms @ 50% 15 ms @500%
AGLD 	1.875 in. (46.2 mm)	LED Display Electromechanical Relay Auto reset SPDT: 1A@125 VAC or 2A@30 VDC Latching SPST: 1A@125 VAC or 2A@30 VDC	Indicated on LED Display Adjustable Set point: AGL1: 5 – 100 mA AGL2: 80 – 950 mA Adjustable delay	120 VAC or 24 VAC/DC	120 ms
AG-LC	4.0 in. (101.6 mm)	Electromechanical Relay Auto reset SPDT: 1A@125 VAC or 2A@30 VDC Latching SPST: 1A@125 VAC or 2A@30 VDC	Adjustable Set point: AG1: 30 – 150 mA AG2: 80 – 400 mA AG3: 300 – 1500 mA AG4: 1.0 – 5.0 A Adjustable delay 0.1 – 8.0 sec	120 VAC or 24 VAC/DC	100 ms @90% over set point

MONITORING APPLICATIONS – The ability to precisely monitor ground fault leakage allows the operator to make determinations on how to handle any ground fault conditions. In applications where deterioration over time is expected, the monitoring of ground leakage levels can determine specific maintenance or replacement needs and prevent costly unexpected equipment failure and shutdowns. There are numerous applications where leakage to ground can exceed 30 mA, yet be safe from causing harm. In some circumstances disconnecting power prematurely may cause significant machine or process damage. Environmental conditions may elevate leakage, such as excessively humid or wet conditions caused by washdown. Some motor types will have minor flaws in the insulation system, which over time may degrade – increasing ground fault leakage.

FIXED SETPOINTS – In applications where actions are required at predetermined or specified leakage levels, the factory calibrated setpoint will simplify setup. Once the setpoint is established, the designer chooses how to specifically handle the fault. Code may determine the sequence of events once a fault occurs. NK Technologies offers a variety of triggering relay solutions, including solid state or electromechanical relays, energized or deenergized initial states, and auto reset or latched configurations.

ADJUSTABLE SETPOINTS – Adjustable setpoints address specific field conditions warranting changes in setpoints. NK Technologies offers field selectable (Tri-Set) or potentiometer adjustable setpoint options along with adjustable time delays before the output relay contacts change state.



Solutions for Industry

Wet Environments

Environments facing a wide range of temperature and moisture conditions wreak havoc on electrical systems. Changes in heat and humidity eventually break down protective insulation causing ground leakage. Wet environments pose additional concerns as potential shock hazards multiply. Ground fault protection is critical in maintaining safe and reliable working environments and in monitoring equipment health. NK Technologies ground fault sensors are ideal in submersible pump motor applications, providing a simplified alternative to moisture sensors housed in the motor casing. Unlike moisture sensors that must be wired back to the motor control center, the ground fault sensor is installed directly in the motor control center, minimizing wiring. By detecting the ground fault current resulting from moisture ingress or other potentially dangerous conditions, remedial action can be taken prior to catastrophic failure. Either the pump can be replaced at the next convenient time or it can be switched off in favor of a back-up pump.

NK Technologies has extensive experience in applications protecting personnel and equipment in wet environments, such as:

Agriculture and Aquaculture

Irrigation pumping systems, filter pumps

Biotech and Biopharma

Laboratories environments that use electrical equipment tied to pumping or processing fluids, or electrically powered heating processes

Chemical Processing

Chemical pumps and mixers, heat trace cables

Food/Beverage, Bottling/Canning

Filling machinery, equipment in washdown/hygienic locations

Fountains

Water jets, nozzle controls

Marinas

Docking facilities (see Ground Fault Detection for High Current Circuits at Marina Docking Facilities)

Material Reduction, Shredders and Grinders

Coolant pumps

Oil and Gas

Downhole pumps and heat trace systems

Pharmaceuticals

Fluid pumping, mixing

Water and Wastewater

Pumping systems, UV Light disinfection systems

Electrical Heating Systems

Industrial electrical heaters (see Electrical Heating System Protection) are prone to ground leakage from the breakdown or contamination of insulation. NK Technologies ground fault sensors enable early detection of leakage currents as small as 5mA. The on/off output of the sensor can be used to trigger a circuit interruption device (for example a shunt-trip breaker) or a monitoring device (like a PLC) to determine the required action. Latching and auto-reset models are available in normally energized or normally de-energized configurations suitable for most applications.

NK Technologies has provided reliable solutions in applications protecting electrical heating systems and the associated processes, including:

Extrusion

Heat trace for extrusion barrel

Furnaces and Kilns

Heat treating and annealing

Manufacturing

Heat trace systems, process heating, annealing, drying, curing, overhead cranes

Semiconductors

Process heating (see Ground Fault Detection in Semiconductor Fabrication Equipment)

Commercial Kitchens

Steamers, grills, ovens (see Adjustable Ground Fault Detection for Commercial Kitchens)

Snow Melt

Snow melt cable to clear sidewalks, driveways and roof gutters



General Equipment Protection

Growing awareness of occupational health and safety has increased the need for protection against ground faults. NK Technologies has over 100 varieties of ground fault sensors that aid in protecting personnel and equipment. Ground fault sensors may be installed at a main breaker to protect the branch circuit or at individual machine feeds to protect equipment. The installed sensors provide an output that can operate a circuit interruption device (like a shunt trip breaker) or feed into an alarm system. By interrupting the current or by alerting an operator, personnel and equipment can be protected.

NK Technologies, a leading supplier of sensor technologies, provides reliable solutions in ground fault applications across a broad range of industries, including:

Entertainment

Amusement park rides, ski lifts, electrified theater chairs, stage lighting and portable power supplies.

Petrochemicals

Process control equipment, pumping systems, heat trace cables

Refrigeration and Compressors

Pumping systems, cooling towers, compressor motors

Timber and Logging

Debarking, sawing, drying, cranes

Utilities and Power Generation

Control systems, transformers, generators, solar panels, wind generators

Ground Fault Detection for High Current Circuits at Marina Docking Facilities

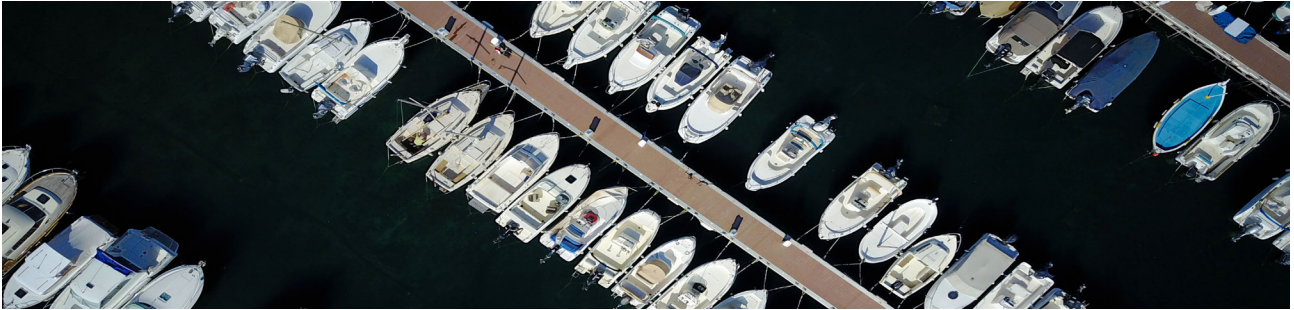

Challenge:

Recent updates to NEC Code 555 require Marina owners to consider ground fault protection at both the individual slips and at the power distribution center feeding the separate branches to each slip's power pedestal. Typical power feeds now require sensors that can handle conductors carrying more than 300 amps necessitating the solution to involve additional components.

Solution:

To address this problem, NK design engineers developed sensor with an aperture measuring four inches in diameter allowing conductors (carrying 800 amps or more) to easily pass through the sensor. These large aperture AG-LC sensors can be used to monitor the main feeding circuit to the pedestals and to energize a shunt trip breaker protecting the entire docking facility. Additionally, the smaller aperture NK Technologies AG Series sensors can be used to monitor individual power pedestals at each slip, with the sensor output energizing a shunt trip breaker circuit at the pedestal.

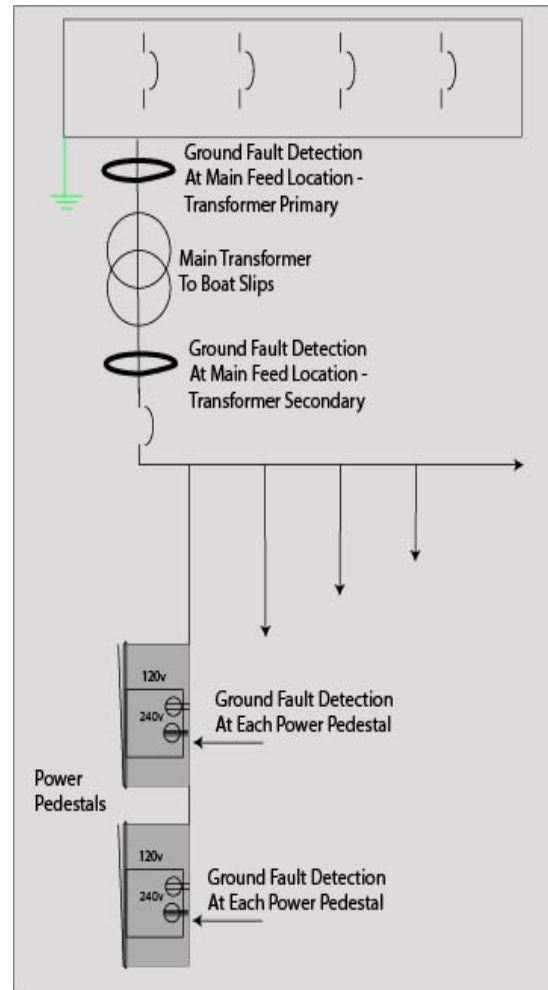

a

Adjustable Ground Fault Detection for Commercial Kitchens



Challenge:

The NFPA NEC 2017 Sec. 210.8 requires electrically operated commercial kitchen equipment with “single-phase receptacles rated 150 volts to ground or less, 50 amperes or less, and three phase receptacles rated 150 volts to ground or less, 100 amperes or less” to have GFCI for personnel protection installed. Prior to this change, only 15- and 20-Amp single phase circuits of 125 volts or less needed this level of protection, with circuit breakers and receptacles meeting this requirement being readily available and quite common. Requirements above 20 amps or needing three-phase protection is a more difficult issue.

Additionally, commercial kitchen steamers and grills sometimes retain humidity while stored prior to installation. To address this issue, units must be “burned in” or energized for a minimum of two hours prior to normal use. The additional moisture present during this process increases the ground fault leakage to a point above the 5-mA desired trip level. To avoid nuisance tripping during the burn in cycle, a ground fault sensor needs to allow a temporary increase in the setpoint.

Solution:

The NK Technologies Tri-Set sensors offers adjustable capabilities as a standard feature. A factory placed range jumper is installed at the highest setpoint (30 mA) allowing the equipment to operate as required during the initial burn-in period. Once the burn in cycle is completed, the sensors can be readjusted to accommodate the desired ongoing 5 mA setpoint. Because of their rugged solid core design and wide operating temperature range capabilities, AG and AGL sensors work well in this environment.

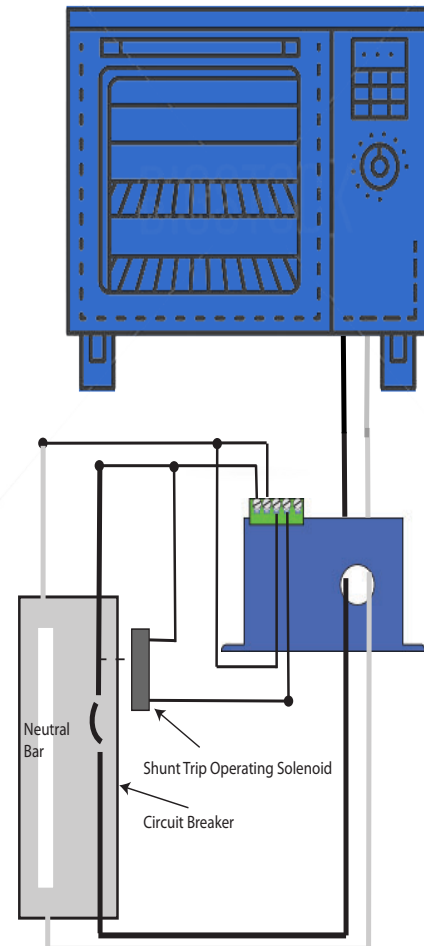

Ground Fault Detection in Semiconductor Fabrication Equipment

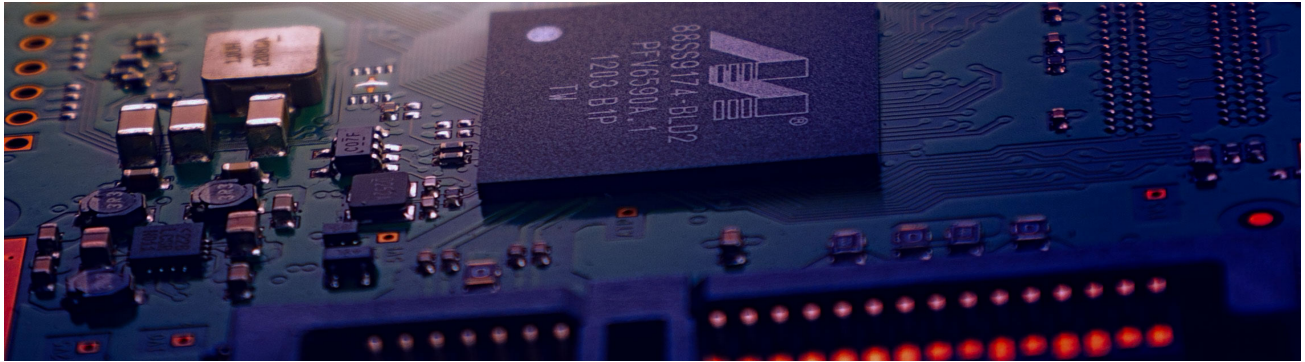

Challenge:

Fabricating silicon wafers into semiconductor chips involves many hazardous chemicals and extreme heat that must be precisely controlled. The SEMI standard S22-071b provides guidelines regarding the safety of semiconductor processing equipment, including Emergency Mains Off (EMO) circuitry design. This requires that if any problem occurs during processing, the operator can easily disconnect mains power. With electrical heating elements used throughout the fabrication equipment, ground fault protection is paramount. As the elements are monitored in each process segment, fault detectors are set at a fairly low trip point. As a fault to earth through the heating element occurs, sensors will selectively shut down only that part of the process. During a situation where several heating processes short at once, a sensor with a bit of delay and higher trip point will shut off the main power feed.

Solution:

NK Technologies wide range of ground fault detection sensors is ideal for the semiconductor manufacturer, allowing optimization of each portion of the fabrication process while protecting machine operators and minimizing or eliminating potential damage to expensive materials. AG and AGL Sensors with adjustable setpoint and delay will help manage the controlled shut down of the system in case of critical failures.



A typical installation of ground fault sensors monitoring several heating circuits used in the semiconductor fabrication process. If a fault to earth is detected, the latching output sensor de-energizes the contactor coil, turning off the offending circuit.

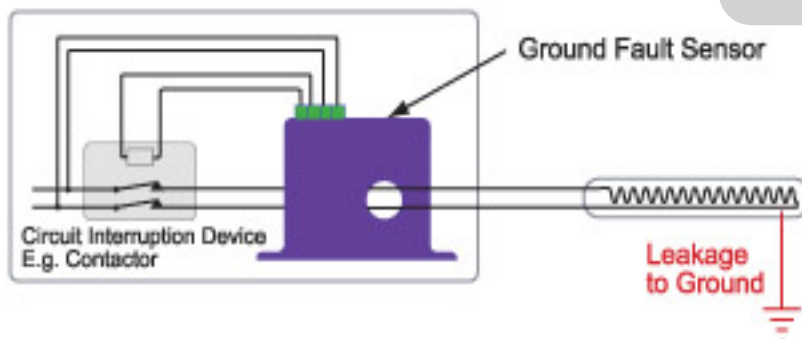

Detecting DC Current Leakage to Earth



Challenge:

Detecting low level AC current without adding a physical connection and added burden to the circuit is relatively easy and quite common. In North America, all electrical outlets mounted in wet environments are required by codes to be protected with ground fault circuit interrupters to save lives by cutting the power when a very small fault to earth is detected. If AC current of 5 to 7mA passes to ground, a circuit breaker or the contacts in the power receptacle open before electrocution can occur. Most electrical heating elements must also be protected to keep equipment from damage in the event of a fault.

Trying to detect the same fault condition in a DC circuit with a floating ground is not as simple. With the proliferation of photovoltaic panels and other alternative power sources, the need for ground fault detection in DC powered systems is critical. With solar panels or battery-operated systems, the positive and negative conductors are insulated to contain the voltage potential between each and also to earth. When connections get wet, this insulation becomes compromised and current can pass to earth. Water is the most common cause of DC fault current, while deteriorating insulation and contaminants on battery housings are additional factors. Since DC current leakage to earth presents a dangerous situation, detecting a fault before it causes harm is essential. Fault detection without adding impedance to the monitored circuit is the safest approach.

Solution:

NK Technologies developed an innovative solution to DC fault detection that employs the same zero-sum principles as its AC offerings. The DG Series DC ground fault relay, used with loads drawing 50 amps or less, can be incorporated at a fraction of the cost of the typical and cumbersome hardwired installations.

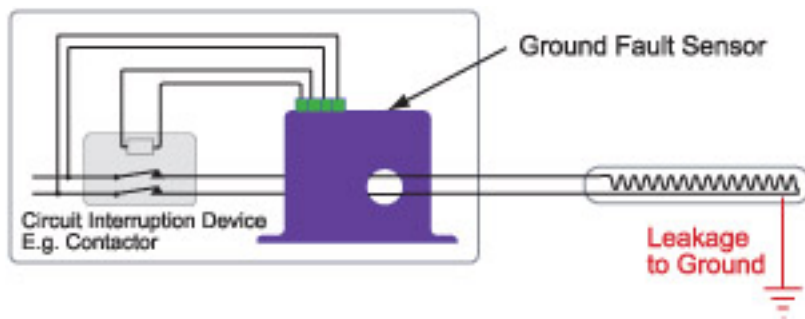

Electrical Heating System Protection

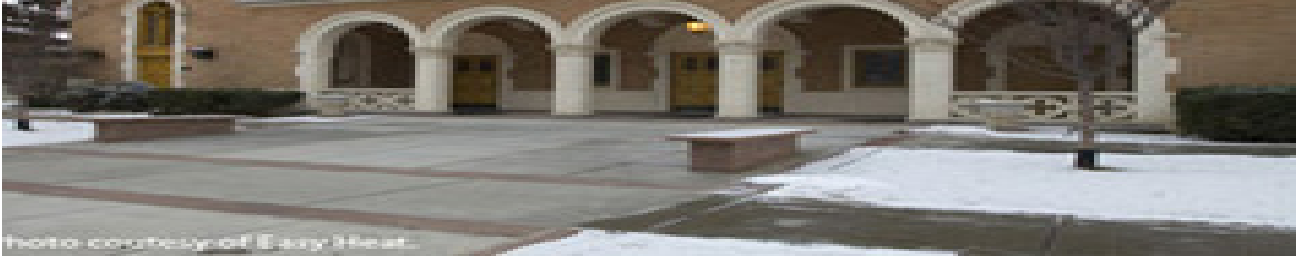

Challenge:

The National Electric Code requires that all (with few exceptions) electric heating sources be protected against faults to ground. Combinations of electrical heating systems and moisture can present a challenge in ground fault protection. Insulation systems of heating elements can degrade over time in the face of wide temperature variations, constant expansion and contraction, and wet conditions. In heating applications it is important to balance protecting personnel while minimizing nuisance trips. Disconnecting the circuit is the best protection in both instances, and the faster the circuit can be de-energized the safer the installation.

Typical Electric Heating Applications:

- Heat Trace Cable
- Snow Melt Mats
- Fuel Preheaters
- Plastic Injection Molding
- Drying
- Finish Curing
- Water Heating
- Baking

Solution:

NK Technologies has a wide assortment of products to achieve an optimal solution based on the application needs. AG series sensors are ideal for lower current applications where a quick disconnect is desired. If there is any current over five milliamps flowing to ground, the sensor can actuate a contact to close a shunt trip breaker solenoid, or in applications where turning off the offending circuit would create a major problem, the contact can be used to alarm an operator or controller. The AGL and AG-LC series makes it possible to monitor conductors carrying over 200 amps (or even larger circuits) for applications with larger heating requirements. NK Technologies also manufactures sensors designed to produce an analog signal directly proportional to the fault current. This output can be used to identify areas where insulation is failing, allowing the user to take corrective measures before equipment is damaged. This range of product allows the designer to optimize the solution that best fits the application requirements.

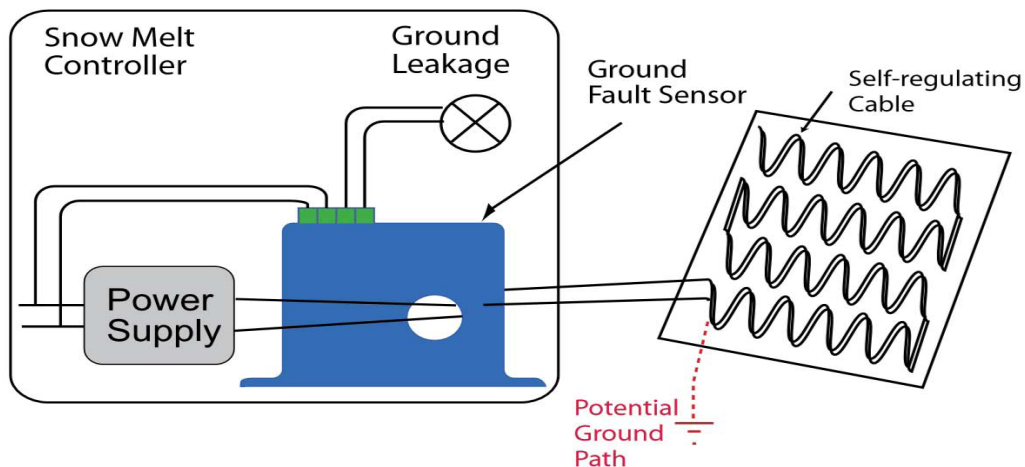

Preventative Maintenance Using Ground Fault Monitors

Challenge:

There are many industrial applications where monitoring electrical heating elements for leakage to earth is needed. Insulation of electrical apparatus may degrade over time contributing to leakage. When a heating process should not be interrupted until the process is completed, disconnecting power through a ground fault circuit interrupter is not an ideal approach. For example, if the heating process is stopped before annealing parts are brought to the target temperature, they will not be properly hardened and must be scrapped. While letting the process complete is not as safe as disconnecting the offending circuit supply source power, it is certainly better and more cost effective than scrapping the parts.

Solution:

NK Technologies provides a smart way to control premature process interruptions utilizing the AGT-FD series. Producing an output signal proportional to this current to earth is a way to monitor deteriorating insulation or direct shorts to ground. The sensor produces a signal which can be read with a panel meter or a programmable logic controller. If the fault current exceeds an allowable level, a limit alarm contact or an output from the PLC can be used to control a signal (audible or visual) letting the equipment operator know a problem is imminent or a hard fault to earth has occurred. The operator can then initiate procedures preventing shutdown of the entire system. With an analog sensor output, there can be multiple alarm points. For example, one alarm would trip if fault current exceeds 10 or 20 mA, while another alarm can trigger when the fault exceeds 50 mA. This allows more extensive action if a higher fault current is detected.

This solution is also ideal for enhancing a preventative maintenance program. Using the same monitoring approach, leakage levels can be established at the point at which preventative maintenance occurs, allowing the offending element to be removed and replaced or another corrective action taken in a cost-effective manner. Additional applications that benefit from this approach include monitoring electric heating processes, semiconductor wafer fabrication, AC motor loads, plastic molding processes, heat trace cable systems, and snow melt protection.

Ground Fault Sensing Basics

Dangers of Electricity Discovered

In October of 1879 Thomas Alva Edison perfected the first practical light bulb. Five years later, Edison hired Nikola Tesla to make direct current (DC) generators more efficient. After a heated disagreement between the two men, Tesla resigned and partnered with George Westinghouse to drive alternating current (AC) as a more efficient means to distribute electricity. As the battle intensified between Edison and Tesla to electrify the world, the lethal dangers posed by electricity began to unfold. Edison saw the inherent dangers of Tesla's solution, so when approached to build an electric chair (even though he was against capital punishment) he saw it as an opportunity to exploit the dangers of AC current. In 1890, the first electric chair, designed by Edison's team and using a Westinghouse AC dynamo, executed a convicted murderer.

The term electrocution was coined by combining electricity and execution to initially describe the effect of the electric chair, but now it relates to any human contact with an electrical source. As electricity usage exploded during the following half century, countless deaths occurred almost exclusively from accidental contact with energized conductors. Finally, in the 1960s, extensive research determined how much current and voltage were needed to cause ventricular fibrillation (where a heart stops beating) in humans. These studies identified that fibrillation occurs with current as low as 70 milliamperes through the heart - conditions that increase the chance of death when in contact with an energized circuit. Once the magnitude of current that can cause harm was established, methods of detecting this low level current and then automatically disconnecting the offending circuit from the power source could be developed. The concurrent refinement of transistor technology provided a solution where currents as low as 0.003 Amps (3 mA) could be sensed and then used to energize a relay to decouple the power supply. Since the 1960s, advances in electronic and mechanical design have realized more sophisticated and effective ground fault leakage sensing, providing enhanced protection for personnel and equipment and resulting in vastly improved home and workplace safety.

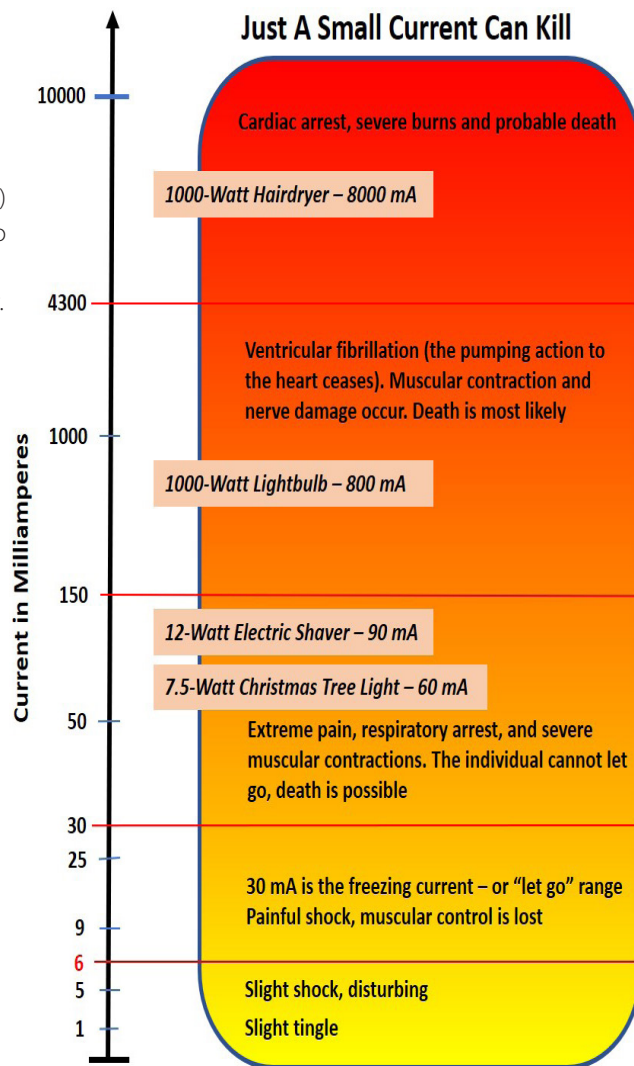

General relationship between the amount of current received and the reaction when current flows from the hand to the foot for just 1 second (Published by OSHA).

- 1 mA, a slight tingle is felt.
- 5 mA, a slight shock is felt, not painful but disturbing. The average individual can let go, but involuntary reactions can lead to injuries.
- 6–25 mA, painful shock, muscular control is lost. (originally related to women)
- 9–30 mA, this is called the freezing current or "let-go" range. At this level many humans cannot get their muscles to work, and they can't open their hand to let go of a live conductor. (originally related to men)
- 50–150 mA, there will be extreme pain, respiratory arrest, and severe muscular contractions. The individual cannot let go, death is possible.
- 1000–4300 mA, there is ventricular fibrillation (the pumping action to the heart ceases). Muscular contraction and nerve damage occur. Death is most likely.
- 10,000+ mA, there will be cardiac arrest, severe burns and probable death.

Source: W.B. Kouwenhoven, "Human Safety and Electric Shock," Electrical Safety Practices, Monograph, 112, Instrument Society of America, p. 93. November 1968.

Earth Fault Detection Requirements

Protecting People

In North America, ground fault circuit interrupters (GFCI) have been required by the National Electric Code (NEC) since the late 1960's. As the technology became more reliable, GFCI were required in many more applications to reduce the number of deaths caused by electrical shock where a human body might become the best path to ground. GFCI receptacles and circuit breakers were a huge step forward with a significant reduction in fatalities leading to a greater interest in ground fault protection. The NEC sets standards for where a GFCI is required and how quickly it should disconnect the circuit. A GFCI is designed to disconnect a circuit if current to earth exceeds 6 mA at 120 VAC. At a low level of fault current it may take a few seconds (UL943A states just under six seconds maximum) before the circuit is de-energized, while at a higher fault current (20 mA or higher) the circuit is disconnected much faster.

The system design engineer follows the NEC Code requirements based on UL943. The UL specification designates what fault current level will cause the circuit to be de-energized and how quickly it must disconnect. The standard residential outlet in a bathroom should be marked as listed to UL943A, which specifies the lowest trip point and the shortest reaction time. Industrial ground fault sensors should be marked as recognized under UL1053, UL508, or one of the other categories of UL943: subsection B, C or D. UL1053 is specific for ground fault sensing and relaying equipment with no stated current levels or time to operate. UL508 is an even broader category that covers a variety of automation components. When using a ground fault sensor to control a shunt trip breaker, both components (sensing device and circuit breaker) must be tested together to verify the circuit is interrupted in the time limits allowed to be considered a UL943 GFCI.

Protecting Processes

While a major concern of ground fault protection covers personnel safety, industrial settings dictate additional considerations. Manufacturing facilities most likely have a variety of safety protections in place for employees working with electrical machinery. Personal Safety Devices (PSD) used properly help minimize exposure to electrical dangers allowing current trip levels to be safely raised minimizing nuisance trips and preventing undesired process interruptions. In addition to personal safety, ground fault detection can be used to initiate controlled stops, alert other upstream processes, and even predict equipment failures.

Underwriters Laboratories has established standards under UL943 for personnel protection (avoiding shock to humans) as well as for equipment protection at various fault levels and reaction time limits. The primary point of equipment protection is to keep a fault from damaging the machine. Circuits supplying heating loads (heat strips, heat trace and snow melting equipment) are usually not disconnected until the fault current exceeds 30 mA or more. Electric vehicle charging stations are now required to have GFCI personnel protection according to 625.22.



Ground fault sensing has wide ranging applications such as melting ice and snow from sidewalks (photo courtesy Joel Silverman, Electrical Agencies in Colorado), protecting industrial equipment and personnel, or in wet applications such as fountains.

The NEC states the following:

- 427.22. Ground-fault protection of equipment shall be provided for electric heat tracing and heating panels. This requirement shall not apply in industrial establishments where there is alarm indication of ground faults and the following conditions apply: (1) conditions of maintenance and supervision ensure that only qualified persons service the installed systems, and (2) continued circuit operation is necessary for safe operation of equipment or processes.
- 426.28. Ground-fault protection of equipment shall be provided for fixed outdoor electric deicing and snow-melting equipment.
- 555.3. The over current protective devices that supply the marina, boat yards, and commercial and noncommercial docking facilities shall have ground-fault protection not exceeding 30 mA.
- 427.22 for heating equipment or in 426.28 covering snow melt systems - there is no stated fault current limit.
- 555.3 for protection at docks clearly shows that the monitored circuit must be disconnected from the load if there is a fault over 30 mA.

The NEC calls for ground fault protection for high current supplies too.

- 215.10 and 230.95 deal with current of 1000 Amps and voltages of 480 or higher.
- 517.17 stipulates where fault detection is required in hospitals and other health care facilities.

The importance of protecting an electrical system against faults to earth cannot be overstated. This type of fault sensing is not over current detection, so fusing or circuit breakers will keep the conductors and insulation from being damaged. NK Technologies offers ground fault sensors that are low cost and simple to install. Rather than combining a detector with a circuit interrupter, the sensor provides contacts to open or close when a fault is detected. The contacts can be used to energize a shunt trip accessory on a circuit breaker, de-energize a contactor coil, or trigger an alarm if the process being monitored should be stopped in an orderly manner.

Detection Methods

The primary method of fault detection utilizes a single ring of magnetically permeable metal wound with many turns of small gauge wire (current transformer or toroid) surrounding all the current-carrying conductors (Fig 1). Whether single or three-phase power, if there is more current supplied to the load than is returned to the source, this sensing toroid produces a low voltage in the windings. This voltage is amplified and used to trigger an action such as energizing a solenoid to open a set of contacts.

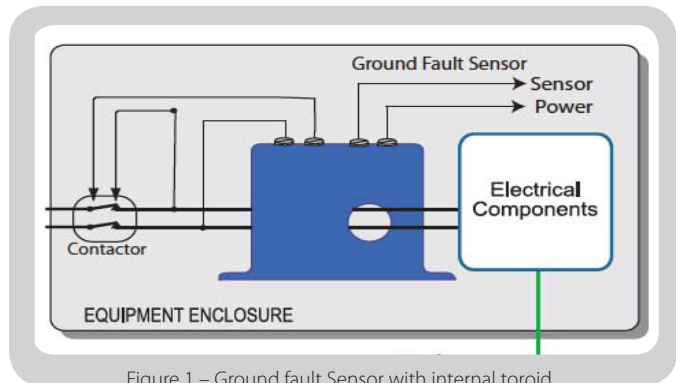

Figure 1 – Ground fault Sensor with internal toroid.

It is also possible to place a toroid over each conductor connecting the secondaries together with a sensing device installed to monitor the resulting circuit (Fig 2). Each toroid or current transformer must be rated to handle the maximum current in each conductor. The accuracy of this multiple toroid method is inherently less precise than using a single toroid due to manufacturing and material tolerances.

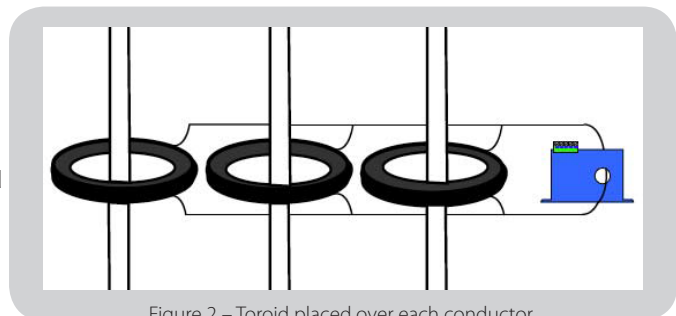

Figure 2 – Toroid placed over each conductor

A similar approach can be used to monitor the entire load of a machine or distribution panel supplied by a wye (star) connected transformer and bonded to earth at the machine location. Passing only the bonding conductor through a ground fault sensor will perform the same function as using a large toroid over all the conductors.

In most industrial applications where ground fault sensing is required or desired, the sensor output is used to perform one of two operations: (1) a contact closes a circuit to energize the operating solenoid of a shunt trip circuit breaker or, (2) a contact opens a circuit powering a contactor or motor starter operating coil. How the sensor output interacts with the rest of the control system is completely at the discretion of the system designer.

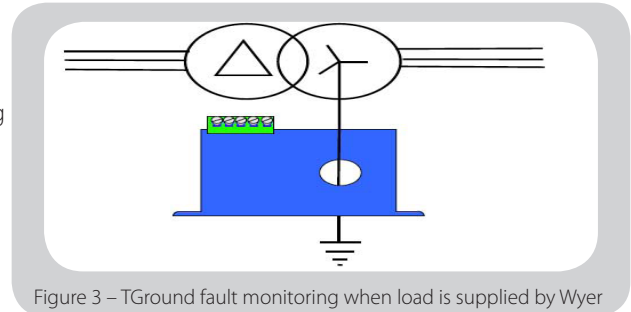
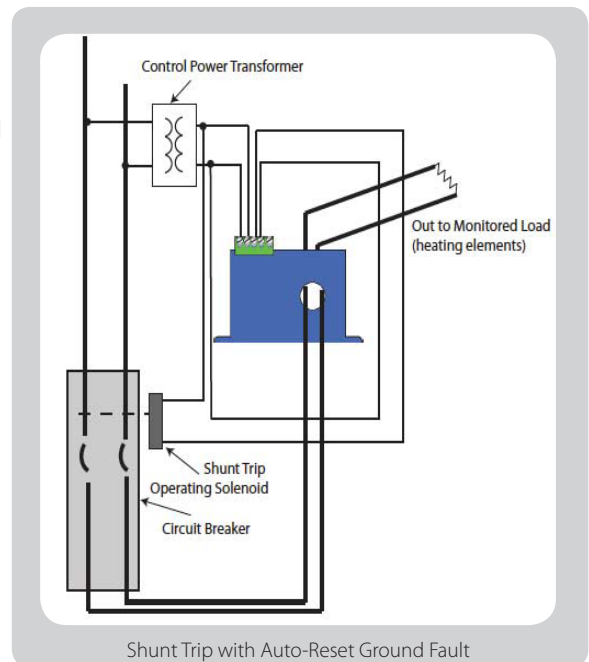

Figure 3 – TGround fault monitoring when load is supplied by Wye

Circuit Breakers and Magnetic Contactors

Circuit breakers come in a variety of styles. Some are designed to accept accessories to increase product versatility (such as, under voltage trip, alarm contacts, and interchangeable trip plugs). Most common is the shunt trip breaker that allows the circuit to be opened from a remote location (acting in the same manner as if there was an over current condition). This action is commonly accomplished by using a magnetically operated solenoid to push or pull a latching mechanism to open the breaker contacts. In some applications the shunt trip device is used to turn off a load in an emergency.

For example, most auto fuel dispensing stations have an emergency switch that will disconnect all fuel pumps if there is a problem. This switch closes the circuit to operate a shunt trip breaker, removing power from the pumps. The circuit breaker must be reset manually once the fault condition has been addressed. For shunt trip use with an auto-reset ground fault sensor, the sensor contact closes the circuit to the shunt solenoid when a fault over the sensor trip point is detected. As in other cases, after the cause of the fault is determined and mitigated, the breaker will need to be reset manually. Since the power to the monitored load is completely turned off, and the only way to restore power is to reset the circuit breaker, using a shunt trip accessory effectively transforms an automatically resetting sensor into a latching device. Even if the cause of the fault is removed from the load and the sensor remains powered from an isolated source (which is recommended for all installations), the load cannot be energized until the breaker is reset. A latching output sensor, like the auto-reset models, is typically equipped with a test button integral to the sensor. Two additional terminals allow attachment of an external contact, usually a button mounted to the enclosure door, enabling the sensor to be reset after a fault is detected without opening the panel.



Another common method used with a ground fault sensor is to have the contact open the circuit providing power to a contactor coil, resulting in de-energizing multiple heating elements or a motor-driven load such as a pump or fan. Opening a contact in a control system sounds easy, but in most ground fault sensing applications, the contact must be closed before the monitored load is energized. Manufacturers offer both normally energized and normally de-energized versions of auto-reset ground fault sensors. The more common of the two is normally de-energized, in which the output, whether solid-state or electromechanical relay, does not change state unless there is a fault to ground exceeding the trip point. The normally energized

version is sometimes referred to as fail-safe. With this type of sensor, the output changes state when the sensor is first powered. The output returns to normal or “shelf-state” condition when one of two things occur: (1) the fault current sensed exceeds the trip point or, (2) the power to the sensor is removed. If a designer selected a normally open, normally energized solid-state output model to open the circuit powering a contactor coil, then the output contact would be open at shelf state and closed when the monitored circuit is not passing current to ground and the sensor is energized. If the sensor power is interrupted, or the monitored load passed current to ground over the trip point, the sensor output will open, turning off the monitored load. It is important to understand that the monitored circuit might not energize if the sensor did not see power first, as energizing the sensor closes the output contact. More commonly the sensor selection would be normally closed, normally de-energized (solid-state) with the contact opening only when current over the trip point passes to ground.

With electromechanical relay outputs the operation is the same. In normally energized versions, the output relay is energized with sensor power applied so that the contacts change state when the sensor has power. The relay will then return to shelf state when there is a loss of power to the sensor or the fault current exceeds the trip point (Fig 5). It is recommended that when an auto-reset sensor output is used to control a contactor, a three-wire wiring method is used (like a standard momentary motor start/stop button setup) so the contactor must be re-engaged after the sensor trips. Alternatively, a latching output version of the sensor is selected.

In some code jurisdictions a contactor might not be considered a circuit disconnect. The local inspector, specifier, or governing agency has the final say. The best place to monitor a circuit for ground faults is in close proximity to the load, rather than a distance upstream from the load. Many system designers tend to specify sensors that will be monitoring several loads at one time by installing the sensor before a final distribution point. While cost effective any minor leakage in each load will accumulate (additive), resulting in a higher leakage current level.

As an example, visualize a machine that produces silicon wafers used to make electronic components. There are several heating elements used to warm water and chemical wash processes and there are several motors for product positioning as well as transformers adjusting voltage levels for various process controls. If the motor and transformer loads are monitored for faults individually and the heating elements are also monitored with separate sensors, the sensors can be set to trip at relatively low levels. However, if a single sensor is used to protect all loads, the trip point will likely need to be set much higher reducing the protection level of each piece of equipment. Heating elements seldom leak low level current as do motors and transformers. In most cases when they fail, there is a direct short to ground or the circuit is completely open. Heat trace cable runs do tend to leak small amounts of current to earth or there may be capacitance losses in long runs. With loads such as motors and transformers, the small imperfections in the varnish insulation of the windings can allow current to pass to earth at very low levels. While current magnitudes of 3 or 4 mA can seldom be felt by a human and will not cause arcing or damage to equipment, this low current leakage can increase over time until it does become a concern both to personnel and the equipment itself.

For the most current
and up-to-date information...

www.nktechnologies.com

- Up-to-date Product Information
- Data Sheets & Instruction Sheets
- CAD Drawings
- Product Certifications
- Request for Quote
- Support
- Application Examples
- Engineering Resource Articles
- Sign up for Product Updates
- Distributor Information
- ... and so much more!

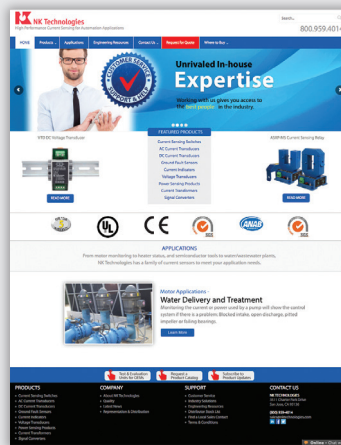

Visit our website for all the technical,
application and support information that you
could ever want or need!

For expert technical help, contact your local Authorized Representative or
Authorized Distributor.



3511 Charter Park Drive • San Jose, CA 95136

800.959.4014 • sales@nktechnologies.com

www.nktechnologies.com

