

DIGITAL VOLTAGE INDICATORS

and ACCESSORIES

Operating & Instruction Manual



HDE HD ELECTRIC COMPANY
A Textron Company

TEquipment
USA
An Interworld Highway, LLC Company

1475 Lakeside Drive • Waukegan, Illinois 60085 U.S.A. • 847.473.4980
fax 847.473.4981 • website: www.HDElectricCompany.com

Call Us 1.877.571.7901

DIGITAL VOLTAGE INDICATORS

and ACCESSORIES

Operating & Instruction Manual

DESCRIPTION4

IMPORTANT SAFETY INFORMATION5

HOW TO USE IT6

ACCURACY6-7

INDICATING VOLTAGE ON ELBOW TEST POINTS8

ACCESSORIES8-9

TECHNICAL SPECIFICATIONS9

CARE AND MAINTENANCE10

WARRANTY AND LIABILITY12



1475 Lakeside Drive • Waukegan, Illinois 60085 U.S.A. • 847.473.4980
fax 847.473.4981 • website: www.HDElectricCompany.com

DIGITAL VOLTAGE INDICATORS



DESCRIPTION

The Digital Voltage Indicators, DVI-100 and DVI-500, are direct contact digital voltage indicators for overhead and underground power distribution systems up to 500kV line-to-ground (870kV line-to-line). The display is auto-ranging and indicates from 0.1kV (100 volts) to 9.9kV and from 10kV to 99kV for the DVI-100 and to 500kV for the DVI-500. An audible alarm beeps whenever the indicated voltage is 0.1kV or higher.

There are two versions available of each model. The DVI-100 and DVI-500 indicate voltage by directly contacting conductors on overhead and underground systems. The DVI-100T and DVI-500T with Test Point mode also indicate voltage on elbow test points.

An optional underground probe is available for underground or pad mount applications, or for any application up to 21kV line-to-ground where the DVI will be used in close proximity to grounded conductors or surfaces.

OPERATIONAL IMPAIRMENT

If the DVI is used in a manner not described in this instruction manual, the protection and effective operation of this equipment may be impaired.

IMPORTANT SAFETY INFORMATION

- Only trained, professional operating personnel should use the DVI. The voltages this instrument operates at are dangerous and lethal. Severe injury or death can occur if improperly used.
- Risk of electrocution is inherent in or around high voltage.
- Always use proper high voltage procedures, including personal protective equipment, when working near or around high voltage equipment or conductors.
- Do not exceed the DVI maximum voltage rating.
- Assemble the DVI with the proper contact probe for your application.
- The DVI must be used with a hotstick of the appropriate length for the voltage being measured per your company and OSHA published requirements.
- Do not touch the DVI during measurements. The DVI housing should be considered to be at the same voltage as the conductor under test.
- Prior to using, inspect the instrument for any physical damage, cleanliness and check for proper working order by pressing and holding the ON button. Do not proceed if the display does not indicate all 8's or if the beeper does not sound.
- Never allow another high voltage or grounded conductor to touch the instrument during use. Keep the DVI housing free and clear of all structures at all times. Bridging the DVI probe or housing from line-to-ground or line-to-line may cause a fault and arc.
- The DVI does not indicate voltages below 100 volts. Always use proper grounding procedures. A zero voltage reading on the DVI **does not** mean the line is dead or grounded.
- Grounded equipment or lines can appear to be live when in close proximity to energized conductors if not fully or properly grounded.
- Always test the DVI on a known voltage source before and after each use, or use the PT-DVI Proof Tester® Voltage Indicator Tester.
- **The DVI is a voltage indicator, not a voltmeter.** Do not attempt to make accurate voltage measurements for phasing or other applications with the DVI.
- The DVI is a direct contact device. The metal portion of the DVI probe must contact the metal conductor to be tested. Voltage indication on insulated conductors such as tree wire or spacer wire will be much lower than actual and may not indicate any voltage at all.
- DVI voltage readings are sensitive to geometry. Read and understand the Accuracy section of this manual before using the DVI.
- The DVI indicates AC voltage only. It does not detect DC voltage such as charged capacitors or cable.

These important labels are affixed to the products. Read and understand before proceeding.

DVI-100

Digital Voltage Indicator Model **DVI-100**

Indicates presence of AC Line to Ground voltage with direct contact to energized conductor from 0.1kV (100V) to 9kV. Beeper indicates presence of voltage.

Press and hold **ON** button before each use to test battery. Press **ON** again for above test point voltage indication and note flashing LED. Press **ON** again for direct contact voltage indication. Verify proper operation on a known voltage source. Reduces battery use with **OFF** indicator or lithium type only. Always use with hot stick with length appropriate for voltage.

CAUTION: Install proper probe before use.

Use overhead probe for overhead testing. Use underground probe for all other applications or when testing in proximity to any grounded conductor or surface up to 2.1 kV.

WARNING: Indicate AC voltage only.

Does not detect DC voltage such as charged capacitors or cable. Do not touch during measurement and keep free of other conductors and grounds. Read and understand instructions. For use by trained professionals only. Misuse or abuse of this product can lead to severe injury or death.

US Patent 6,998,832
www.HDElectricCompany.com
HD Electric Company, Waukegan, IL, U.S.A. 1009

OVERHEAD PROBE TO 9kV
UNDERGROUND PROBE

System kV	DVI L-L	DVI L-G
4	2.4	2.0
12	7.2	6.0
34	20	17
69	40	34
138	80	68

DVI-100T

Digital Voltage Indicator with Bow Test Point Indicator Model **DVI-100T**

Indicates presence of AC Line to Ground voltage with direct contact to energized conductor from 0.1kV (100V) to 9kV. Beeper indicates presence of voltage.

Press and hold **ON** button before each use to test battery. Press **ON** again for above test point voltage indication and note flashing LED. Press **ON** again for direct contact voltage indication. Verify proper operation on a known voltage source. Reduces battery use with **OFF** indicator or lithium type only. Always use with hot stick with length appropriate for voltage.

CAUTION: Install proper probe before use.

Use overhead probe for overhead testing only up to 9kV.

Use underground probe for all other applications or when testing in proximity to any grounded conductor or surface up to 2.1 kV.

WARNING: Indicate AC voltage only.

Does not detect DC voltage such as charged capacitors or cable. Do not touch during measurement and keep free of other conductors and grounds. Read and understand instructions. For use by trained professionals only. Misuse or abuse of this product can lead to severe injury or death.

US Patent 6,998,832
www.HDElectricCompany.com
HD Electric Company, Waukegan, IL, U.S.A. 1009

OVERHEAD PROBE
BOW TEST POINT
UNDERGROUND PROBE

System kV	DVI L-L	DVI L-G
4	2.4	2.0
12	7.2	6.0
34	20	17
69	40	34
138	80	68

DVI-500

Digital Voltage Indicator Model **DVI-500**

Indicates presence of AC Line to Ground voltage with direct contact to energized conductor from 0.1kV (100V) to 500kV. Beeper indicates presence of voltage.

Press and hold **ON** button before each use to test battery. Press **ON** again for above test point voltage indication and note flashing LED. Press **ON** again for direct contact voltage indication. Verify proper operation on a known voltage source. Reduces battery use with **OFF** indicator or lithium type only. Always use with hot stick with length appropriate for voltage.

CAUTION: Install proper probe before use.

Use smaller overhead probe for overhead testing only up to 200kV.

Use larger overhead probe for overhead testing. Above 90kV can be used on overhead bus bars. Do **NOT** use this larger probe on distribution voltage systems below 90kV.

Use underground probe for all other applications or when testing in proximity to any grounded conductor or surface up to 2.1 kV.

WARNING: Indicate AC voltage only.

Does not detect DC voltage such as charged capacitors or cable. Do not touch during measurement and keep free of other conductors and grounds. Read and understand instructions. For use by trained professionals only. Misuse or abuse of this product can lead to severe injury or death.

US Patent 6,998,832
www.HDElectricCompany.com
HD Electric Company, Waukegan, IL, U.S.A. 1108

OVERHEAD PROBE TO 500kV
OVERHEAD PROBE TO 200kV
UNDERGROUND PROBE

System kV	DVI L-L	DVI L-G
4	2.4	2.0
12	7.2	6.0
34	20	17
69	40	34
138	80	68
230	130	110
345	200	170
500	290	245
765	440	365

DVI-500T

Digital Voltage Indicator with Bow Test Point Indicator Model **DVI-500T**

Indicates presence of AC Line to Ground voltage with direct contact to energized conductor from 0.1kV (100V) to 500kV. Beeper indicates presence of voltage.

Press and hold **ON** button before each use to test battery. Press **ON** again for above test point voltage indication and note flashing LED. Press **ON** again for direct contact voltage indication. Verify proper operation on a known voltage source. Reduces battery use with **OFF** indicator or lithium type only. Always use with hot stick with length appropriate for voltage.

CAUTION: Install proper probe before use.

Use smaller overhead probe for overhead testing only up to 200kV.

Use larger overhead probe for overhead testing. Above 90kV can be used on overhead bus bars. Do **NOT** use this larger probe on distribution voltage systems below 90kV.

Use underground probe for all other applications or when testing in proximity to any grounded conductor or surface up to 2.1 kV.

WARNING: Indicate AC voltage only.

Does not detect DC voltage such as charged capacitors or cable. Do not touch during measurement and keep free of other conductors and grounds. Read and understand instructions. For use by trained professionals only. Misuse or abuse of this product can lead to severe injury or death.

US Patent 6,998,832
www.HDElectricCompany.com
HD Electric Company, Waukegan, IL, U.S.A. 1108

OVERHEAD PROBE TO 500kV
OVERHEAD PROBE TO 200kV
UNDERGROUND PROBE
BOW TEST POINT

System kV	DVI L-L	DVI L-G
4	2.4	2.0
12	7.2	6.0
34	20	17
69	40	34
138	80	68
230	130	110
345	200	170
500	290	245
765	440	365

HOW TO USE IT

Test the DVI battery and display by pressing and holding the ON button. Verify that the display reads all 8's and the beeper sounds. If needed, replace the 9V battery with an alkaline or lithium type. The DVI will shut off automatically four minutes after the display returns to zero or it can be shut off manually by pressing and holding the ON button until the display shuts off.

Install the appropriate probe securely to the DVI. Use the overhead hook probes, the smaller hook can be used up to 99kV and the larger hook 100kV and above, for overhead applications with clearance sufficient to keep the DVI housing away from any other live or grounded conductor. Use the optional insulated underground probe for underground or pad mount applications including loadbreak bushings, metal clad switchgear or any other applications where grounded or other live conductors may be in close proximity to the conductor being tested. Some overhead applications such as fuse cutouts, switches, disconnects, terminations or measurements made near a pole or crossarm may call for use of the underground probe due to the close proximity of grounds. **Never allow the DVI to bridge between two energized conductors or from an energized conductor to ground.**

Always install the DVI on a hotstick with length appropriate for the voltage to be measured by way of the built-in universal spline, making certain it is securely attached.

Test the DVI on a known voltage source before and after each use, such as the PT-DVI Proof Tester Voltage Indicator Tester.

Apply the DVI probe to the conductor to be tested making sure to make metal to metal contact.

All readings are in kV. Voltages below 0.1kV (100V) may indicate zero. A zero voltage reading does not mean the line is dead or grounded. Voltage in excess of 99kV line-to-ground for the DVI-100 and in excess of 500kV for the DVI-500 will cause the display to flash and may damage the unit.

ACCURACY

The DVI indicates voltage based on the electric field strength surrounding a conductor. Electric field strength can be greatly influenced by the geometry of a conductor and the presence of other nearby conductors. For best accuracy, keep the DVI at least three feet (one meter) away from inside or outside corners or points and position the face of the DVI away from other live conductors and towards ground. The following guidelines may be helpful:

- The DVI may read up to 25% higher than actual voltage when placed on outside corners or points.
- The DVI may read up to 25% lower than actual voltage when placed on inside corners.
- The DVI may read up to 25% higher than actual voltage if measurements are taken with a ground in close proximity.
- The DVI may read up to 25% higher or lower if other phases are nearby, such as from an overbuild.
- When checking for voltages on conductors believed to be grounded, make the measurement and keep the DVI as far away as possible from energized conductors and position the face of the DVI towards ground. When checking pole guy wires, make the measurement as close to ground as possible.

For best overall accuracy, the following guidelines may be helpful:

Best overall accuracy is with a single energized conductor (Fig. 1), midspan with no nearby grounds.

Expected accuracy is +/- 3%.

In a typical overhead three phase system with horizontal spacing, the best accuracy is on the two outside conductors (Fig. 2).

Expected measurement accuracy on the two outside conductors is +/- 5%

On the center conductor, expected accuracy is +/- 10%.

In more complex situations with transmission or other higher voltage overbuild, accessory hardware such as fuses or disconnects or for measurements made on points such as terminations or endpoints, best accuracy is with the DVI as far away as possible from other live conductors or grounds, away from points or corners and facing the ground (Fig. 3 & 4).

Expected overall accuracy is +/- 25%.

For measurements made on grounded conductors, keep the DVI as far away as possible from energized conductors and face the DVI towards ground (Fig. 5).

Readings on grounded conductors with nearby energized conductors may indicate 0.1 to 0.2kV or more.

For best accuracy with readings on pad mount equipment, livefront (shown) or deadfront, keep the DVI housing clear of adjacent grounds (Fig. 6). DVI with IEP-DVI-5 probe shown.

Expected overall accuracy is +/- 10%.

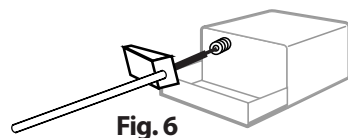
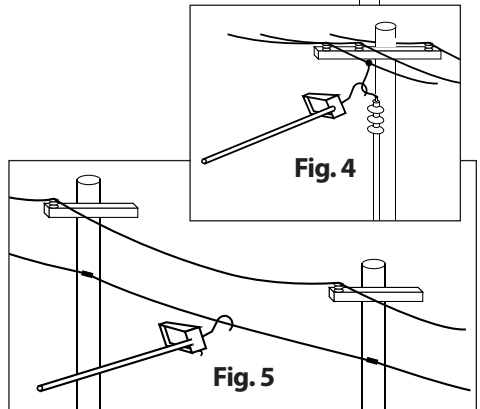
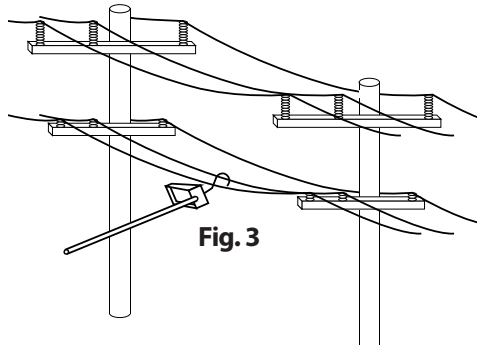
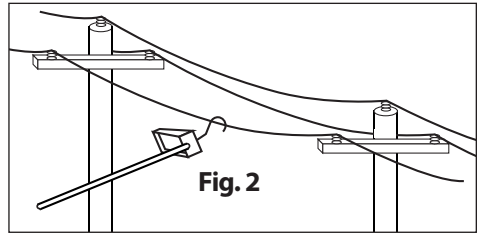
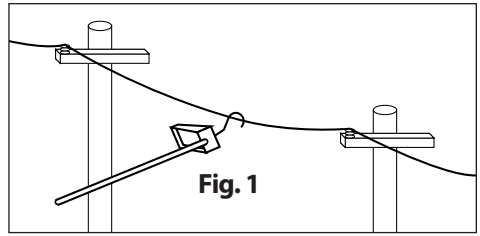

INDICATING VOLTAGE ON ELBOW TEST POINTS

DVI-100T AND DVI-500T ONLY

The DVI-100T and DVI-500T can be set to indicate voltages on elbow test points. For checking elbows and all other pad mount or underground equipment, first install the IEP-DVI-5 underground probe.

For checking elbow test point voltages, turn the DVI on by pressing the **ON** button. Press the **ON** button again for test point mode, indicated by the flashing decimal point.

All elbow test point voltage indications are in kV, calibrated for line voltage. For example, an elbow energized at 7.2kV will indicate 7 as shown here. Expected accuracy is +/- 10%. Variations among elbows from different manufacturers or vintages can be as much as +/- 25%.

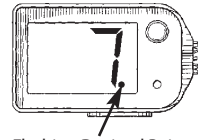

Flashing Decimal Point

To cancel test point mode, press the **ON** button again. Test point mode will be automatically cancelled if the indicated voltages exceeds 99kV.

ACCESSORIES

IEP-DVI-5 UNDERGROUND BUSHING PROBE

The IEP-DVI-5 Underground Bushing Probe is designed for direct insertion into exposed 15, 25 or 35kV loadbreak bushings (after connecting elbows have been removed and properly stored). The probe must be inserted directly into the bushing and remain free and clear of all surrounding surfaces. It is rated for use up to 21kV line-to-ground. This probe should also be used in metal clad switchgear or any other applications where grounded or other live conductors may be in close proximity to the conductor being tested. To assemble the IEP-DVI-5 probe on the DVI:

1. Inspect the IEP-DVI-5 probe for any mechanical defects and make certain it is clean and dry.
2. Screw the IEP-DVI-5 into the DVI. Make certain it is snug by hand tightening, but **DO NOT OVERTIGHTEN**.
3. Test the fully assembled DVI on a known voltage source, such as the PT-DVI Proof Tester Voltage Indicator Tester, prior to using.



PT-DVI PROOF TESTER FOR DVI VOLTAGE INDICATORS

The PT-DVI Proof Tester Voltage Indicator Tester is for use on the DVI with any available probes. This tester generates high voltage AC for testing the DVI. To use, turn on the DVI, hold the Tester in one hand and the DVI in the other. Apply the DVI probe to the metal end plate on the Tester. Press and hold the TEST button on the Tester. A properly operating DVI-500 will indicate a voltage of 0.2-0.5kV depending on how the DVI and Tester are held and a DVI-100 will indicate 1.5-4.5kV. For best results, hold both units with a tight grip and wrap your fingers around each unit. If the DVI does not indicate voltage, do not use it and return it to HD Electric Company for service.

CAUTION: This Tester generates high voltage AC for testing DVI AC voltage indicators. There is no danger of electric shock when this tester is used as directed. Discontinue use and return to HDE for service if the housing is cracked or broken, or if the battery cover is lost.

 **CAUTION:** High Voltage

WARNING: Do not use this tester except as directed. Do not use to test equipment other than specified DVI Voltage Indicators. Do not apply to energized circuits or equipment. Do not operate this Tester without the battery cover and do not open the housing. Refer all servicing to the factory. Failure to follow these instructions may lead to electric shock, severe injury or death.

OTHER ACCESSORIES

The DVI-100 comes standard with (1) HP-DVI-2 small overhead hook probe and a CS-DVI carrying case. The DVI-500 comes standard with (1) HP-DVI-2 small overhead hook probe, (1) HP-DVI-6 large overhead hook probe and a CS-DVI-5 carrying case. Both cases can accommodate the IEP-DVI-5 underground bushing probe, the PT-DVI Proof Tester Voltage Indicator Tester and a spare 9V battery.

ADAPTER FOR SHOTGUN STICK (HSA-2500)

HOTSTICKS

A range of hotsticks are available in lengths starting at 4'. Contact HD Electric for more details.

ENVIRONMENTAL CONDITIONS

CONDITIONS: Indoor and outdoor use

ALTITUDE: Up to 6,566 ft. (2000M)

OPERATING TEMPERATURE: -20°F to +140°F (-29°C to +60°C)

HUMIDITY: 95% to +60°C (non-condensing)

POLLUTION DEGREE: PD4

MEASUREMENT CATEGORY IV

OVERVOLTAGE CATEGORY IV



TECHNICAL SPECIFICATIONS

MODEL NUMBER: DVI-100, DVI-100T,
DVI-500 and DVI-500T

OPERATING VOLTAGE DVI-100: 0 - 99kV (0.1kV - 9.9kV and 10kV - 99kV)

RANGES: DVI-500: 0 - 500kV (0.1kV - 9.9kV and 10kV - 500kV)

OPERATING FREQUENCY: 60Hz (50Hz available)

DIMENSIONS: Display housing: 4.25"H x 7"W x 4.5"D (11 cm x 18 cm x 11 cm)

Overhead probes: HP-DVI-2: 8" long (20 cm) for conductors to 1" diameter

HP-DVI-6: 12" long (30 cm) for conductors to 6" diameter

WEIGHT: 1.37 lb. (0.62 kg) with overhead probe

LED HEIGHT: DVI-100: 2.25" (6 cm)

DVI-500: 1.45" (3.7 cm)

ACCURACY: Laboratory calibrated to +/- 3%

Typical overhead line in compact overhead three phase +/- 10%

Other applications up to +/- 25%

BATTERY: 9V alkaline 1604A, IEC 6LR61 or 9V lithium, ANSI-1604LC.

BATTERY LIFE: About 100 readings with 9V alkaline

ENCLOSURE MATERIAL: Supertough nylon UL94-HB

PRINTED CIRCUIT BOARDS: FR-4 UL94V-0

BATTERY REPLACEMENT INSTRUCTIONS

To replace the battery, open and remove the compartment on the bottom of the DVI housing. Remove and dispose of the old battery, replacing it with a fresh, new 9-volt lithium or alkaline battery. Note battery polarity on the battery compartment. This compartment cannot be reinserted if the battery polarity is reversed.

CARE AND MAINTENANCE

STORAGE - It is recommended for protection of the DVI that it and its accessories are stored in the carrying case provided.

CLEANLINESS - The molded housing is very rugged, but it should be kept clean and free of dirt, grease and any other foreign materials. If the housing surface integrity has been compromised in any way, remove from service and return to factory for repair or replacement.

CLEANING INSTRUCTIONS - To clean the DVI wipe with a damp cloth with water. Do not use harsh chemicals or solvents.

DAMAGE - If you suspect any mechanical or electrical damage, do not use the DVI and arrange for repair by returning to the factory.

CALIBRATION & TESTING - Regular calibration of the DVI is not required. There is no accessible calibration adjustment.

SERVICE - Return to HD Electric Company for service.

MANUFACTURING LOCATION

HD Electric Company • Waukegan, IL. 60085, USA



Call Us 1.877.571.7901

LIMITED WARRANTY AND LIMITATION OF LIABILITY

This warranty applies to all products sold by HD Electric Company (the "Products"); provided, however, that the term Products does not include any third party products purchased through HD Electric Company, for which no warranties are made (the "Third Party Products"). Third Party Products may be subject to a separate manufacturer's warranty; [should you have any question regarding whether a separate warranty applies, please contact HD Electric Company].

NOTICE: READ THIS LIMITATION OF WARRANTY AND LIABILITY BEFORE BUYING OR USING THE PRODUCTS CONTAINED HEREIN.

It is impossible to eliminate all risks associated with the use of the Products. Risks of serious injury or death, including risks associated with electrocution, arcing and thermal burns, are inherent in work in and around energized electrical systems. Such risks arise from the wide variety of electrical systems and equipment to which Products may be applied, the manner of use or application, weather and environmental conditions or other unknown factors, all of which are beyond the control of HD Electric Company.

HD Electric Company does not agree to be an insurer of these risks, and shall have no liability for any claims arising from such risks.

WHEN YOU BUY OR USE THESE PRODUCTS, YOU AGREE TO ACCEPT THESE RISKS.

HD Electric Company warrants to the original purchaser that the Products (excluding any third party products purchased through HD Electric Company, for which no warranties are made) will be free from defects in material and workmanship, under normal use and regular service, and preventative maintenance for a period of one (1) year (ten (10) years for HDE Capacitor Controls) from the date of shipment (the "Warranty Period"). Should any failure to conform with this warranty be found during the Warranty Period, you must notify HD Electric Company of your claim within thirty (30) days of discovery, and within the Warranty Period. Your failure to give notice of claims of breach of warranty within the Warranty Period shall be deemed an absolute and unconditional waiver of claims for such defects. HD Electric Company will have no responsibility to honor claims received after the date the applicable Warranty Period expires.

Upon notice of your claim, HD Electric Company will provide a return authorization number, and further instructions on how to return the product for service. You must follow HD Electric Company's instruction. You are responsible for all Product removal, handling, re-installation, and shipping (both to and from HD Electric Company). Products returned for repair, as well as repaired or replacement Products shall be sent postage / freight prepaid. After receipt of a product which HD Electric Company determines is defective, HD Electric will, at its option, either (1) repair (or authorize the repair of) the Product or (2) replace the Product, subject to the following: The Products are made using parts sourced from a variety of manufacturers. Due to the rapidly changing technology environment, parts may become obsolete / unavailable over time (end of life). In the event that a Product cannot be repaired or replaced due to unavailability of parts, HD Electric Company will use commercially reasonable efforts to obtain substitute parts or conduct work around design, but cannot guarantee its ability to do so.

Items not found defective will be returned at your expense, or failing receipt of instruction from you on return of such items within five (5) business days of our notice to you that the product is not defective, HD Electric may dispose of the product at its discretion and with no liability to you. HD Electric Company's determination of defects is final. Products repaired or replaced during the Warranty Period shall be covered by the foregoing warranties for the remainder of the original Warranty Period or ninety (90) days from the date of delivery of the repaired or replaced Products, whichever is longer.

LIMITATIONS:

This warranty is void in the event of misuse, alteration, faulty installation, or misapplication of the product.

This warranty does not cover failure of product or components due to any ACT OF NATURE; lightning, floods, hurricanes, tornadoes or any other such catastrophic events.

HD Electric Company does not warrant any third party products or associated hardware or their performance or suitability for use and application. Such items are provided "as-is".

All repairs must be authorized by HD Electric Company. Unauthorized repairs will not be reimbursed under any circumstances.

HD Electric Company is not required to make replacement or loaner equipment available while Products are being repaired or replaced, or to compensate you for any in/out labor charges or expenses associated with removal, handling or re-installation of the Products.

TO THE MAXIMUM EXTENT PERMITTED BY LAW, THIS WARRANTY AND THE REMEDIES SET FORTH ABOVE ARE EXCLUSIVE AND IN LIEU OF ALL OTHER WARRANTIES, REMEDIES AND CONDITIONS, WHETHER ORAL OR WRITTEN, EXPRESS OR IMPLIED. HD ELECTRIC EXPRESSLY DISCLAIMS ALL OTHER WARRANTIES OF ANY KIND, EXPRESS OR IMPLIED, INCLUDING WITHOUT LIMITATION IMPLIED WARRANTIES OF FITNESS FOR A PARTICULAR PURPOSE, MERCHANTABILITY AND NON-INFRINGEMENT.

IN NO EVENT SHALL HD ELECTRIC COMPANY BE LIABLE FOR ANY INDIRECT, INCIDENTAL, CONSEQUENTIAL OR SPECIAL DAMAGES RESULTING FROM THE USE OR HANDLING OF THESE PRODUCTS. THIS SHALL INCLUDE BUT, NOT LIMITED TO, LOST PROFITS OR REVENUE, LOSS OF USE OF THE PRODUCTS, COST OF SUBSTITUTE PRODUCTS, FACILITIES OR SERVICES, OR DOWNTIME.

IN NO EVENT SHALL HD ELECTRIC COMPANY HAVE ANY LIABILITY FOR ANY THIRD PARTY PRODUCTS OR ASSOCIATED HARDWARE, OR CUSTOMER-OWNED SYSTEMS, EQUIPMENT OR SOFTWARE.

HD Electric Company must have prompt notice of any claim so that an immediate product inspection and investigation can be made. Buyer and all users shall promptly notify HD Electric Company of any claims, whether based on contract, negligence, strict liability, or other tort or otherwise be barred from any remedy.

HD Electric Company is committed to ongoing review and improvement of its product lines, and thus reserves the right to modify product design and specifications without notice.

HD Electric Company® products are available through HDE® sales representatives worldwide.

Printed in U.S.A. © HD Electric Company 2016 • Bulletin No. DVI IM-1000

US Patent 6,998,832 US Patent D510,882