

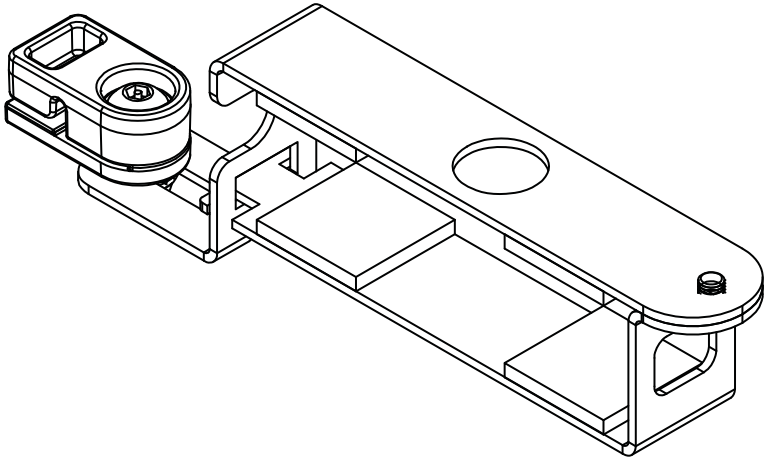

Installation and Assembly:  
**Projector Wireless Integration Module**

---

**Model: HDS-PWM-200**



205 Westwood Ave, Long Branch, NJ 07740  
Phone: 866-94 BOARDS (26273) / (732)-222-1511  
Fax: (732)-222-7088 | E-mail: [sales@touchboards.com](mailto:sales@touchboards.com)

**NOTE:** Read entire instruction sheet before you start installation and assembly.

## ▲ WARNING

- Do not begin to install your Peerless product until you have read and understood the instructions and warnings contained in this Installation Sheet. If you have any questions regarding any of the instructions or warnings, for US customers please call Peerless customer care at 1-800-865-2112, for all international customers, please contact your local distributor.
- This product should only be installed by someone of good mechanical aptitude, has experience with basic building construction, and fully understands these instructions.
- Make sure that the supporting surface will safely support the combined load of the equipment and all attached hardware and components.
- Always use an assistant or mechanical lifting equipment to safely lift and position equipment.
- Tighten screws firmly, but do not overtighten. Overtightening can damage the items, greatly reducing their holding power.
- This product is intended for indoor use only. Use of this product outdoors could lead to product failure and personal injury.

## Tools Needed for Assembly

- phillips screwdriver
- 7/16" open end wrench

Before you start check the parts list to insure all of the parts shown are included.

Parts List		
Description	Qty.	Part #
A wireless mount	1	180-1213
B 5/32" allen wrench	1	560-9646
C 10-32 x 1/4 serrated washer head socket pin screw	1	510-1056

**NOTE:** Actual parts may appear slightly different than illustrated.

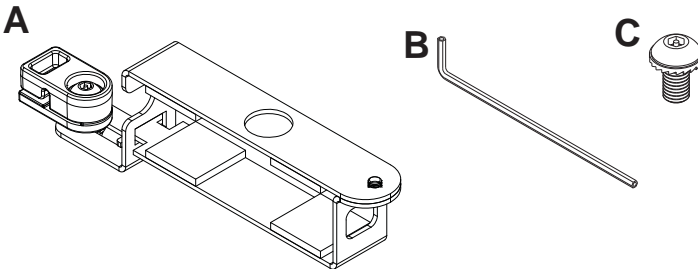

- 1 Remove 10-32 x 1/4" screw from wireless module (A). Position wireless receiver (sold separately) in wireless module. Secure in place by reinserting 10-32 x 1/4" screw.

For security applications, install 10-32 x 1/4 serrated washer head socket pin screw (C) in place of the 10-32 x 1/4" phillips screw and secure using 4mm security allen wrench (B).

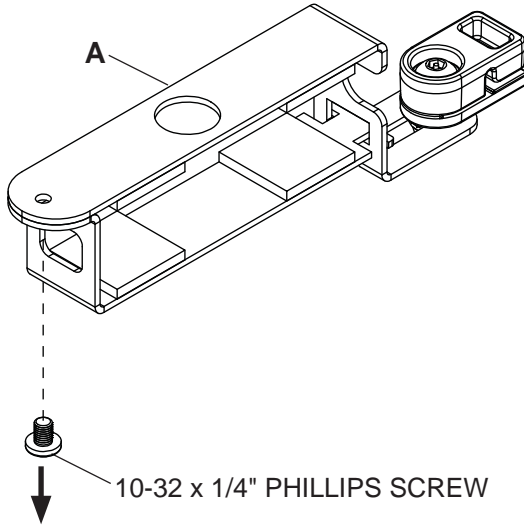

WIRELESS RECEIVER  
(SOLD SEPARATELY)

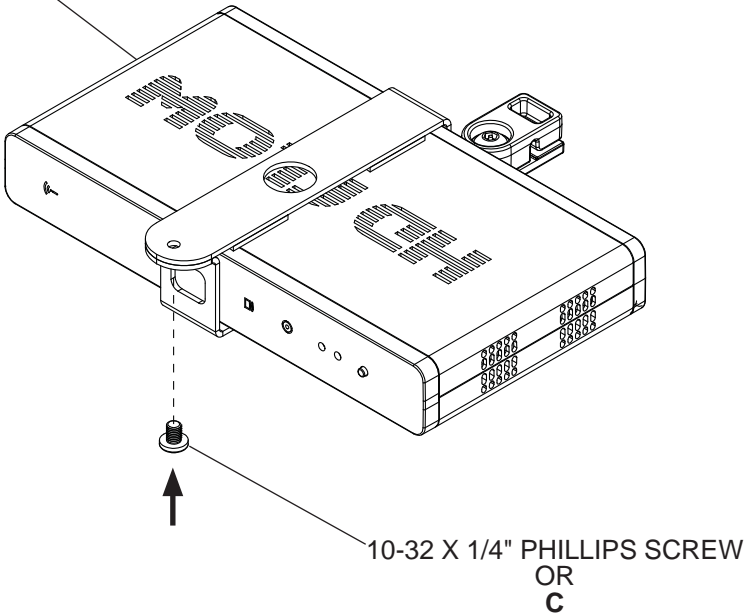

- 2 Remove the projector from the projector mount. Loosen the 1/4-20 x 7/8 socket pin screw on the clamp of wireless module (A). Position the clamp of wireless module (A) on the clamping plate of the projector mount adapter plate. Tighten the 1/4-20 x 7/8 socket pin screw.

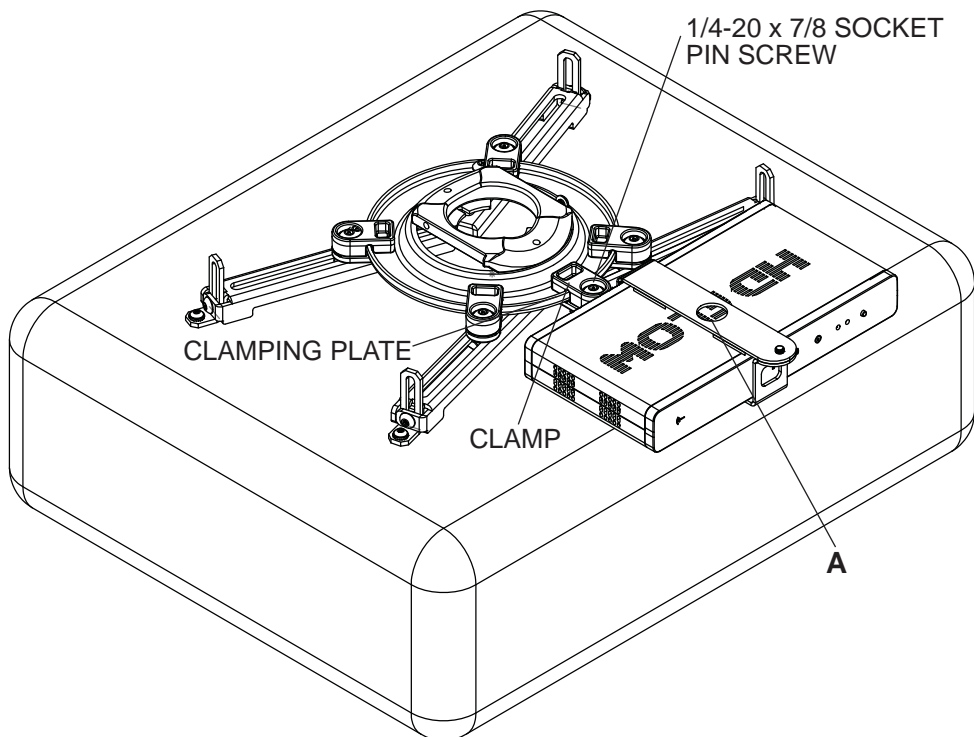

- 3 Plug the component cable(s) from your projector (HDMI shown) into the wireless receiver. Re-install projector.

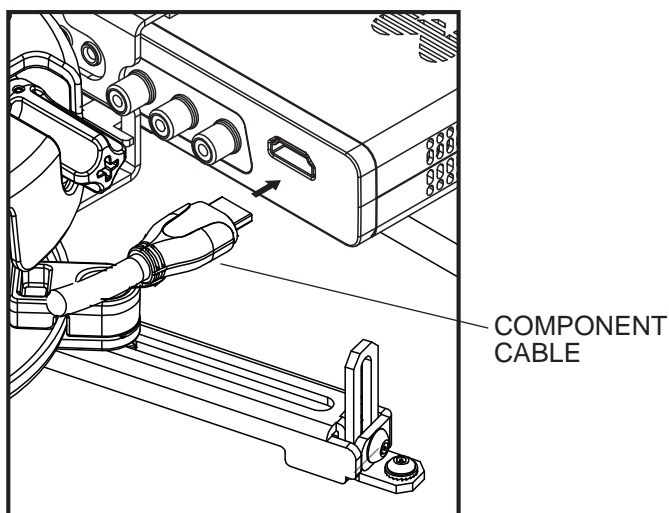

- 4 Plug the end of the wireless receiver power adapter into the input port marked **DC** on the wireless receiver as shown. Plug the other end into your power source.

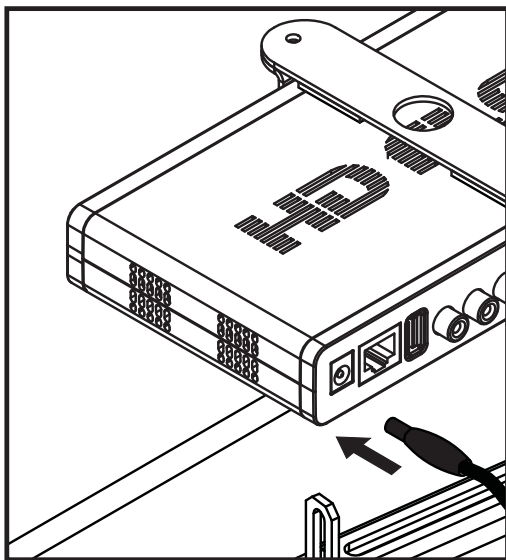

- 5 To complete the installation of your wireless projector, please refer to the HDS200 User's Manual and the HDS200 Install Guide included.

This page intentionally left blank.

# LIMITED WARRANTY

Peerless Industries, Inc. ("Peerless-AV®") warrants to original end-users of Peerless-AV® products that Peerless-AV® products will be free from defects in material and workmanship, under normal use, for the periods listed below, from the date of purchase by the original end-user. At its option, Peerless-AV® will repair or replace with new or refurbished products or parts, or refund the purchase price of any Peerless-AV® product which fails to conform with this warranty.

**In no event shall the duration of any implied warranty of merchantability or fitness for a particular purpose be longer than the period of the applicable express warranty set forth above.** Some states do not allow limitations on how long an implied warranty lasts, so the above limitation may not apply to you.

This warranty does not cover damage caused by (a) service or repairs by the customer or a person who is not authorized for such service or repairs by Peerless-AV®, (b) the failure to utilize proper packing when returning the product, (c) incorrect installation or the failure to follow Peerless-AV®'s instructions or warnings when installing, using or storing the product, or (d) misuse or accident, in transit or otherwise, including in cases of third-party actions and force majeure. This warranty also does not cover corrosion or rust resulting from damaged, scratched or chipped paint or other surfaces.

**In no event shall Peerless-AV® be liable for incidental or consequential damages or damages arising from the theft of any product, whether or not secured by a security device which may be included with the Peerless-AV® product.** Some states do not allow the exclusion or limitation of incidental or consequential damages, so the above limitation or exclusion may not apply to you.

This warranty is in lieu of all other warranties, express or implied, and is the sole remedy with respect to product defects. No dealer, distributor, installer or other person is authorized to modify or extend this Limited Warranty or impose any obligation on Peerless-AV® in connection with the sale of any Peerless-AV® product.

This warranty gives specific legal rights, and you may also have other rights which vary from state to state.

<u>Product</u>	<u>Warranty Period</u>
Mounts	5 years
Furniture	1 year
Cables	25 years
Cleaning Products	1 year
Electronic Products and components	1 year

**peerless-AV®**

[www.peerless-av.com](http://www.peerless-av.com)

© 2012 Peerless Industries, Inc.

# Touchboards

205 Westwood Ave, Long Branch, NJ 07740  
Phone: 866-94 BOARDS (26273) / (732)-222-1511  
Fax: (732)-222-7088 | E-mail: [sales@touchboards.com](mailto:sales@touchboards.com)

# peerless-AV<sup>®</sup>

**Peerless-AV**  
2300 White Oak Circle  
Aurora, IL 60502  
Email: [tech@peerlessmounts.com](mailto:tech@peerlessmounts.com)  
Ph: (800) 865-2112  
Fax: (800) 359-6500  
[www.peerless-av.com](http://www.peerless-av.com)

**Peerless-AV Europe**  
Unit 3 Watford Interchange,  
Colonial Way, Watford, Herts,  
WD24 4WP, United Kingdom  
Customer Care  
44 (0) 1923 200 100  
[www.peerless-av.com](http://www.peerless-av.com)

**Peerless-AV de Mexico**  
Ave de las Industrias 413  
Parque Industrial Escobedo  
Escobedo N.L Mexico 66050  
Servicio al Cliente  
01-800-849-65-77  
[www.peerless-av.com](http://www.peerless-av.com)