

SW2010

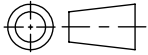

Revision level		Revision Record	Changed	Date	Approved	Date
Drawing	Part					
01		SEE ECN# 012253	AAC	12/28/2012	AAC	01/03/2013

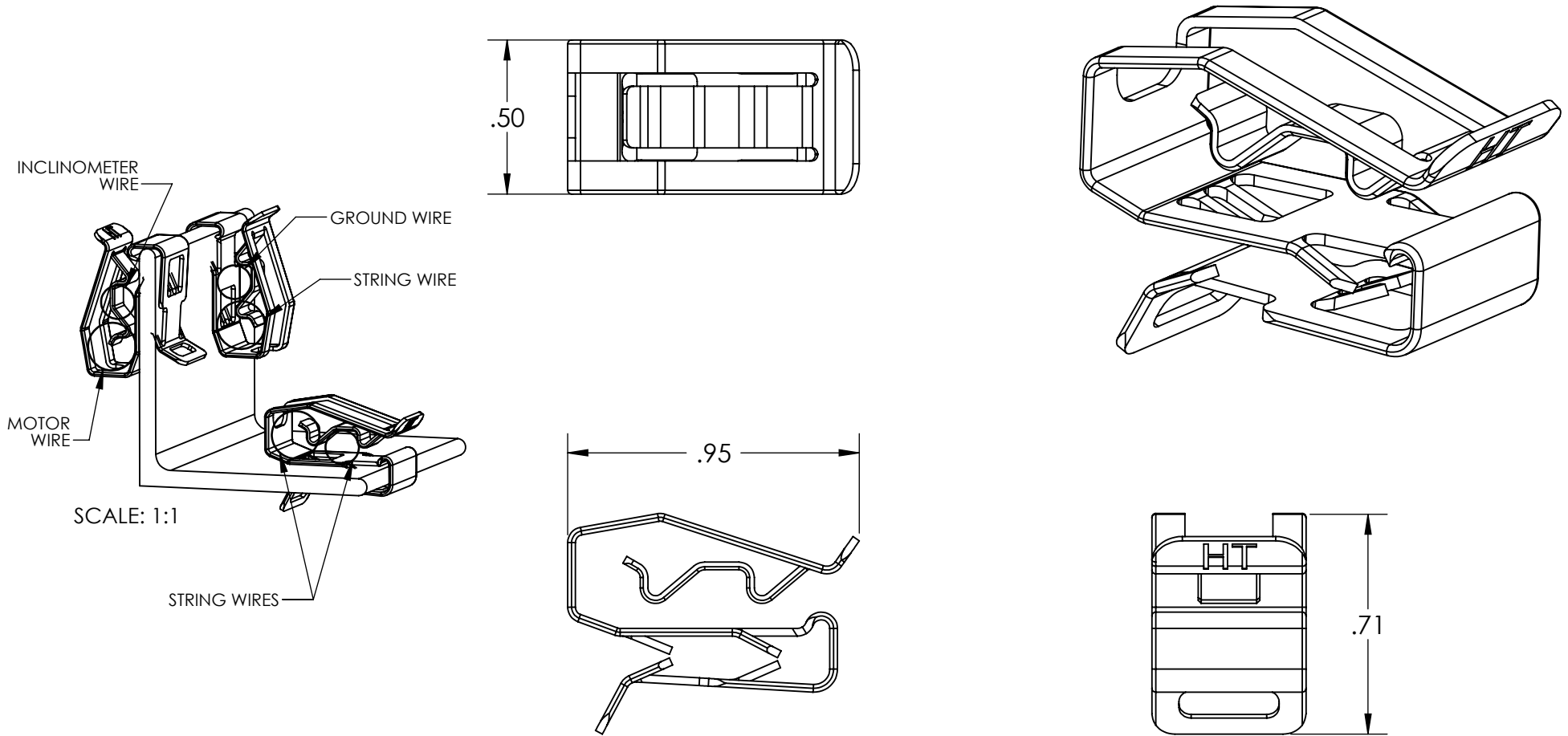

**Material**  
304 3/4 HARD STAINLESS  
STEEL ROUND EDGE

- NOTES:  
 1. MINIMUM PANEL THICKNESS: 1MM  
 2. MAXIMUM PANEL THICKNESS: 3MM  
 3. MINIMUM CABLE DIAMETER: 5MM  
 4. MAXIMUM CABLE DIAMETER: 7.6MM

Units inches  
 Dimension without tolerances  
 details to:  
 .xxxx = ±.0005  
 .xxx = ±.005  
 .xx = ±.01  
 .x = ±.03  
 None = ±.06  
 ∠ = ±0.5°

The copyright of this drawing is reserved by HellermannTyton. It is issued on condition that it is not reproduced, copied, or disclosed to a third party, either wholly or in part, without the consent of HellermannTyton.

Drawn	WPT	05/04/2012	Article/Type-No	MSC2	Scale	2:1	
Approved	WPT	07/31/2012	Title	METAL SOLAR CLIP	Project Number	PRP11-0158	
<b>HellermannTyton</b> North America Email: corp@htamericas.com Web: www.hellermann.tyton.com			Drawing-No	11-0158-012-CSU	Production : Phase	Format	AH
			Sheet	1/1			