

HAKKO FM-2031

SOLDERING IRON

Heavy Duty N₂ Soldering Iron

Instruction Manual

Thank you for purchasing the HAKKO FM-2031 Soldering Iron. The HAKKO FM-2031 soldering iron is designed to supply hot gas to the soldering area. This can increase soldering efficiency, as the gas pre-heats the work area. When the heated gas is nitrogen (N₂), soldering efficiency is further improved as nitrogen materially reduces the amount of oxygen in the ambient atmosphere. Please read this manual before operating the HAKKO FM-2031. Keep this manual readily accessible for reference.

CAUTION
Please refer to the instruction manual of the HAKKO FM-206 Rework Station or HAKKO FM-203 Soldering Station when used in conjunction with the HAKKO FM-2031.

1. PACKING LIST AND PART NAMES

Please check to make sure that all items listed below are included in the package.

HAKKO FM-2031	1	Iron holder	1
Heat resistant pad	1	Connecting cable	1

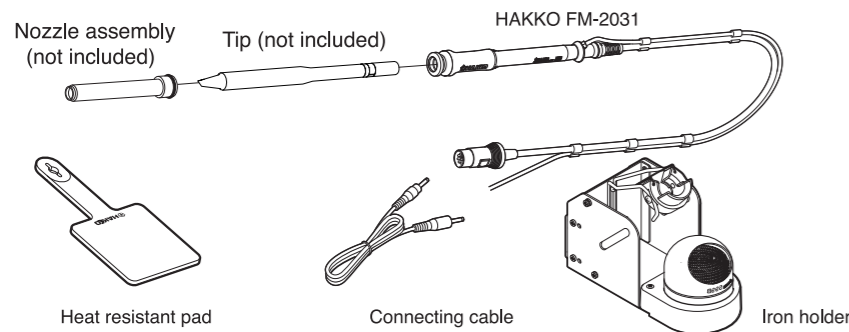

2. SPECIFICATIONS

● HAKKO FM-2031

Power Consumption	140W(24V)
Temperature range	200~500°C (400~930°F)(when connected to main unit)
Tip to Ground Resistance	< 2 Ω
Tip to Ground Potential	< 2 mV
Length of cord	1.2 m
Length (w/o cord)	231 mm with 2.4D tip
Weight (w/o cord)	47 g with 2.4D tip and nozzle assembly E

*Specifications and design are subject to change without notice.

*This product is protected against electrostatic discharge.

3. COMPATIBLE STATIONS

This N₂ soldering iron is compatible for use with the following models:

- HAKKO FM-203 (Soldering station)
- HAKKO FM-206 (Rework station)
- HAKKO FX-780 (N₂ generator)
- HAKKO FX-791 (N₂ station)

NOTE :

If connecting the gas supply line to other than the HAKKO FX-780 and FX-791, refer to the connection diagram in section "5 INITIAL SETUP" as a guide for using this product.

■ Electrostatic Protection

This product includes such features as electrically conductive plastic parts and grounding of the handpiece and station as measures to protect the device to be soldered from the effects of static electricity. Be sure to observe the following instructions:

1. The handle and other plastic parts are not insulators, they are conductors. When making repairs or replacing parts, take sufficient care not to expose live electrical parts or damage insulation materials.
2. Be sure to ground the unit during use.

4. WARNINGS, CAUTIONS, NOTES AND EXAMPLES

Warnings, cautions and notes are placed at critical points in this manual to direct the operator's attention to significant items. They are defined as follows:

WARNING: Failure to comply with a WARNING may result in serious injury or death.

CAUTION: Failure to comply with a CAUTION may result in injury to the operator, or damage to the items involved.

NOTE: A NOTE indicates a procedure or point that is important to the process being described.

WARNING

When power is ON, tip temperature will be between 200°C and 500°C (400 to 930°F). To avoid injury or damage to personnel and items in the work area, observe the following :

- Inform others in the area that the unit is hot and should not be touched.
- Turn the power off when not in use, or left unattended.
- Turn the power off when changing parts or storing the HAKKO FM-2031.
- Do not modify the unit.
- Do not allow the HAKKO FM-2031 to become wet, or use it when hands are wet.
- N₂ gas is hot. Do not direct N₂ gas toward personnel.
- This appliance is not intended for use by persons (including children) with reduced physical, sensory or mental capabilities, or lack of experience and knowledge, unless they have been given supervision or instruction concerning use of the appliance by a person responsible for their safety.
- Children should be supervised to ensure that they do not play with the appliance.

● To prevent accidents or damage to the HAKKO FM-2031, be sure to observe the followings:

CAUTION

- Do not touch the tip or the metal parts near the tip.
- Do not allow the tip to come close to, or touch, flammable materials.
- Do not use the HAKKO FM-2031 for applications other than soldering.
- Do not strike the iron against hard objects to remove excess solder. This will damage the iron.
- Use only genuine HAKKO replacement parts.
- Be sure to hold the plug when inserting or removing the iron cord.
- Since smoke is produced when using the HAKKO FM-2031, be sure the work area is well ventilated.
- While using the HAKKO FM-2031, do not do anything which may cause bodily harm or physical damage.

5. INITIAL SETUP

● Connection

CAUTION

The tip may be hot. Avoid holding the hot tip for a long time even if using the heat resistant pad. Otherwise burns may result.

A. Insert the tip and nozzle assembly

1. Insert the tip into the HAKKO FM-2031 until it stops. (Fig.1)



NOTE :

Please use only T22 Series Tips. The attempted use of other tips may damage the product and/or station.

2. Insert a compatible nozzle assembly into the tip until it stops after fitting the tip. (Fig.2)
(See "Cross reference guide for tip and nozzle" of "9. PARTS LIST" on back page for the compatible nozzle assembly.)



B. Soldering iron

- Pass the iron cord through the hole in the heat resistant pad. (Fig.3)

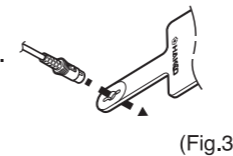

C. Station

- If used in conjunction with HAKKO FM-203 Connect the cord assembly of the HAKKO FM-2031 to channel D connector of HAKKO FM-203.
- If used in conjunction with HAKKO FM-206 Connect the cord assembly of the HAKKO FM-2031 to channel 2 or channel 3 connector of HAKKO FM-206.

NOTE :

The HAKKO FM-203 has 2 channels ; D and S channel. The HAKKO FM-2031 can be connected to only the D channel. The HAKKO FM-206 has 3 channels ; 1, 2 and 3 channel. The HAKKO FM-2031 can be connected to channel 2 or 3. Refer to the HAKKO FM-203/FM-206 instruction manual for details of operation.

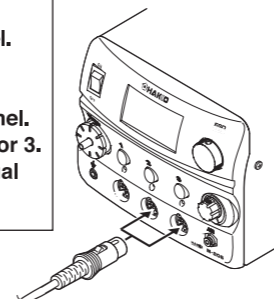

5. INITIAL SETUP

CAUTION

- When connecting or disconnecting the cord assembly, hold the plug.
- Be sure to turn off the power switch before connecting or disconnecting the cord assembly for the soldering iron to and from the receptacle to avoid damaging the unit.

● Use of the sleep function

When using the sleep function, insert one end of the connecting cable into the jack at the back of the iron holder and the other end into the jack at the back of the station to connect them.

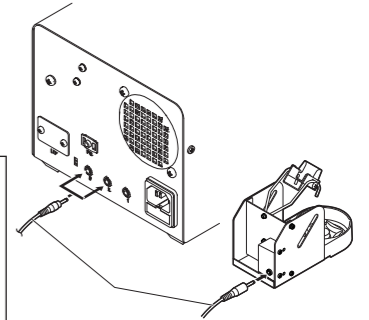

CAUTION

- Please make sure the power is off when you plug in cables.
- Please make sure to hook up the connector cable and the iron holder on the same channel and not to place the iron in a holder connected to a differing channel.

D. N₂ station

Insert the tube of the HAKKO FM-2031 to the terminal marked "OUT" of the HAKKO FX-791. (Refer to the instruction manual for the HAKKO FX-791.) If the HAKKO FX-791 is not used, refer to the following diagram for connection and use without HAKKO FX-791.)

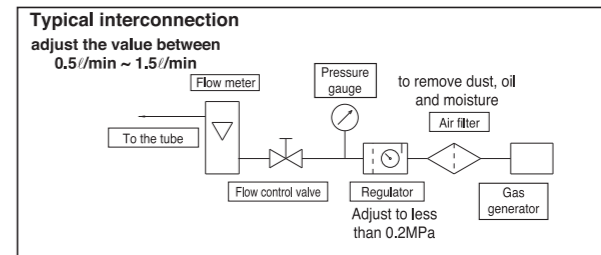

6. OPERATION

CAUTION

- Shut off the gas supply when the HAKKO FM-2031 is left unattended for an extended period.
- N₂ gas is hot. Do not direct N₂ gas toward personnel.

1. Turn on the power switch for HAKKO FM-203 Soldering station or FM-206 Rework Station. Set the appropriate section as needed. Refer to the HAKKO FM-203 or FM-206 instruction manual.
2. Turn on N₂ gas and adjust the rate of flow to be appropriate. (Suggested flow rate : 0.5 L / min ~ 1.5 L / min)
3. Measure the tip temperature when it is stabilized. Input the offset value to adjust the set temperature display. (Refer to the HAKKO FM-203 or FM-206 instruction manual.)

CAUTION

Ensure that the gas pressure to the HAKKO FM-2031 is less than 0.2MPa (2.0kgf/cm²). If the pressure exceeds 0.2Mpa, damage may occur. Tip temperature may not reach the set value if the gas flow rate exceeds the specified limit.

7. CHECKING PROCEDURE



1. Check for a broken heater
Check the heating element for electric fault. Measure the resistance across these positions. (15 to 25°C; 59 to 77°F). Normal resistance value is 4Ω ±10%. If resistance value is abnormal, replace the tip with a new one.
2. Check the grounding line.
If the resistance value is higher than 2Ω (at room temperature), remove the black oxide or replace the tip with a new one. If the resistance value still does not decrease, check the connection cord for breakage.
3. Checking the connection cord for breakage.
Measure the resistance between the connector pins. Between pin 1 and pin 3: 3.6 to 4.4Ω. If the resistance value is different from the above values, replace the HAKKO FM-2031.

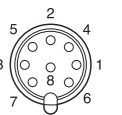

8. MAINTENANCE

Maintenance of nozzle assembly

As the unit is used, oxidation will accumulate on the nozzle tip.
Remove it periodically by cleaning so that the gas will flow freely.

9. PARTS LIST

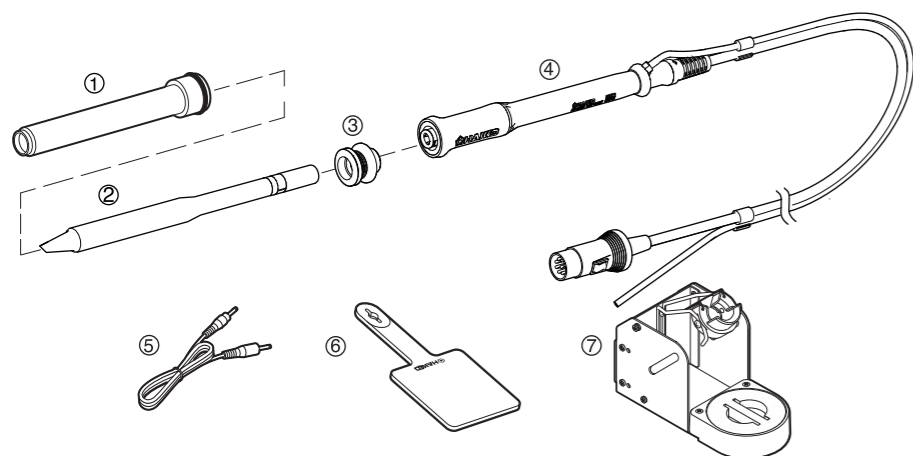

●HAKKO FM-2031

Item No.	Part No.	Part Name	Specifications
①		Nozzle assembly	See "Cross reference guide for tip and nozzle"
②		Tip	See "10.TIP STYLES"
③	B3687	Nipple	With O-ring
③ ④	FM2031-01	HAKKO FM-2031	24V-140W
③ ④ ⑤ ⑥ ⑦	FM2031-02	HAKKO FM-2031	24V-140W Conversion kit
⑤	B3253	Connecting cable	
⑥	B2300	Heat resistant pad	
⑦	FH200-01	Iron holder	

●Iron Holder

Item No.	Part No.	Part Name	Specifications
①	B3001	Iron receptacle	With screws
②	B2791	Retaining clip	
③	B3248	Holder for iron receptacle	
④	B3251	Iron holder base	With rubber foot
⑤	B3249	Cleaner base	With rubber foot
⑥	B3250	Stay	
⑦	B3252	Switch case assembly	
⑧	599B-02	Tip cleaner	
⑨	599-029	Cleaning wire	

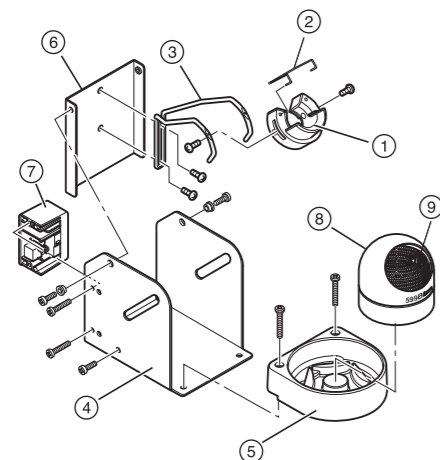

9. PARTS LIST

●Cross reference guide for tip and nozzle

Tip		Nozzle	
Part No.	Tip shape	Part No.	Part Name
T22-BL	BL	B3121	Nozzle assembly A
T22-BL2	2BL		
T22-BC2	2BC		
T22-C3	3C		
T22-D12	1.2D		
T22-J02	0.2J	B3123	Nozzle assembly C
T22-D08	0.8D		
T22-D16	1.6D		
T22-K	K	B3124	Nozzle assembly D
T22-C5	5C		
T22-C6	6C		
T22-D32	3.2D		
T22-D45	4.5D		
T22-D52	5.2D	B3561	Nozzle assembly E
T22-D24	2.4D		
T22-JD08	0.8JD		

※各言語（日本語、英語、中国語、フランス語、ドイツ語、韓国語）の取扱説明書は以下のURL、HAKKO Document Portalからダウンロードしてご覧いただけます。
（商品によっては設定の無い言語がありますが、ご了承ください）
*各言語（日本語、英語、中文、法語、ドイツ語、韓国語）の使用説明書は通過以下网站的HAKKO Document Portal 下载参阅。
（有一部分的产品没有设定外语对应，请见谅）
• Instruction manual in the language of Japanese, English, Chinese, French, German and Korean can be downloaded from the HAKKO Document Portal.
(Please note that some languages may not be available depending on the product.)

<https://doc.hakko.com>

10. TIP STYLES

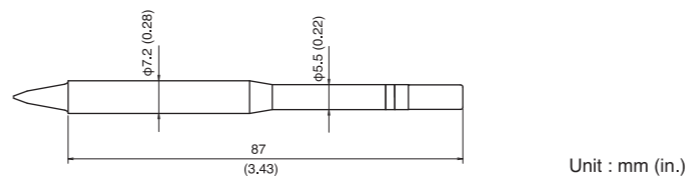

T22-BL SHAPE-BL T22-BL2 SHAPE-2BL T22-BC2 SHAPE-2BC T22-C3 SHAPE-3C

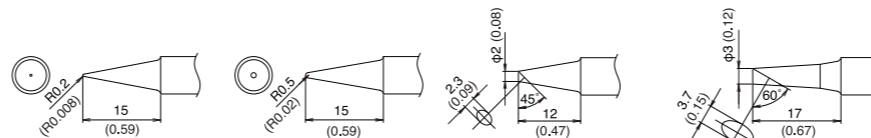

T22-C5 SHAPE-5C T22-C6 SHAPE-6C T22-D08 SHAPE-0.8D T22-D12 SHAPE-1.2D

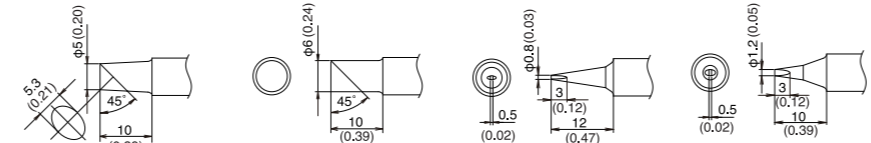

T22-D16 SHAPE-1.6D T22-D24 SHAPE-2.4D T22-D32 SHAPE-3.2D T22-D45 SHAPE-4.5D

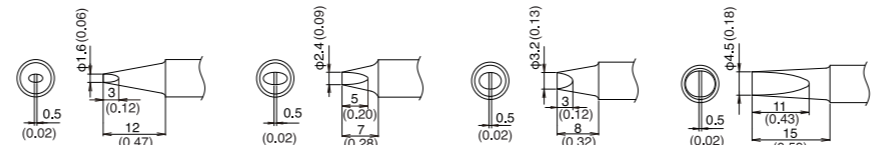

T22-D52 SHAPE-5.2D T22-J02 SHAPE-0.2J T22-JD08 SHAPE-0.8JD T22-K SHAPE-K

