

# **HAKKO** FM-205 DESOLDERING TOOL

## Desoldering tool **Instruction Manual**



Thank you for purchasing the HAKKO FM-205 desoldering station.  
Please read this manual before operating the HAKKO FM-205.  
Keep this manual readily accessible for reference.



### **TABLE OF CONTENTS**

1. PACKING LIST AND PART NAMES .....	1
2. SPECIFICATIONS .....	2
3. WARNINGS, CAUTIONS, NOTES AND EXAMPLES .....	3
4. INITIAL SETUP .....	4
5. OPERATION .....	7
6. PARAMETER SETTINGS .....	11
7. MAINTENANCE .....	14
8. ERROR MESSAGES .....	20
9. TROUBLESHOOTING GUIDE .....	21
10. PARTS LIST .....	23
11. WIRING DIAGRAM .....	26

# 1. PACKING LIST AND PART NAMES

Please check to make sure that all items listed below are included in the package.

HAKKO FM-205 desoldering station .....	1	Iron holder with tip cleaner .....	1
MODEL FM-2024 desoldering tool .....	1	Handle (for gun configuration) .....	1
Filter pipe assembly (For replacement) .....	1	Cleaning drill (for heating element) .....	1
Control card .....	1	Nozzle remover .....	1
Power cord .....	1	Ceramic paper filter (For replacement/10 pcs.) ....	1
Connecting cable .....	1	Tip tray .....	1
		Instruction manual .....	1

## ● HAKKO FM-205 desoldering station

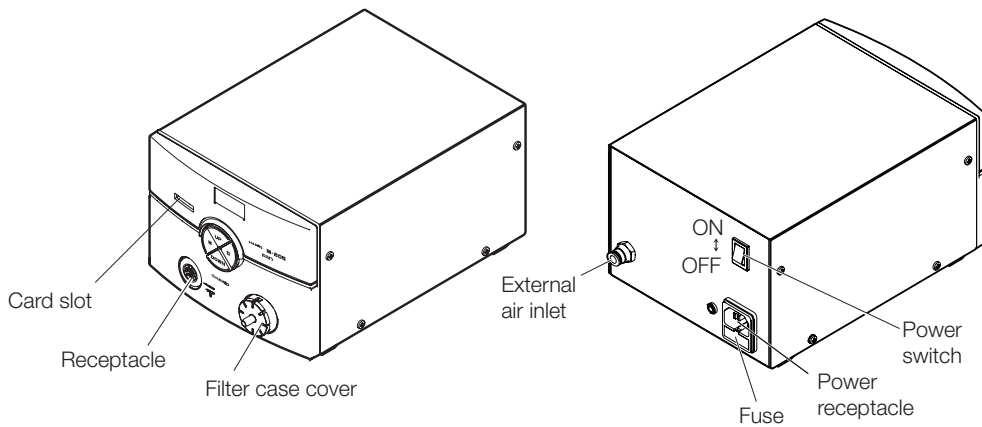

## ● Accessories

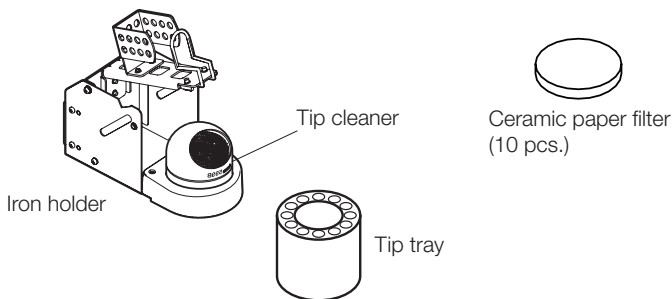
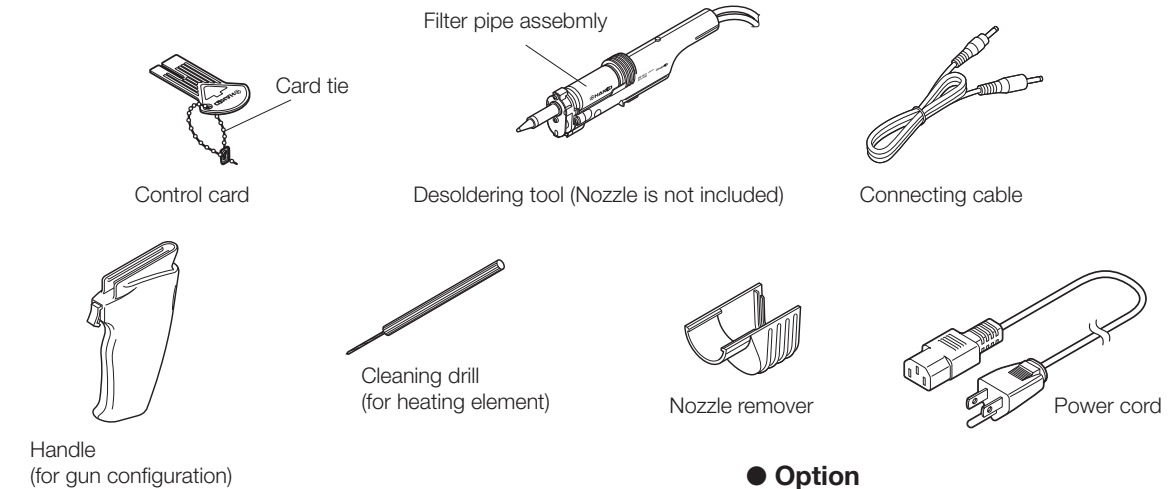

## ● Option

HAKKO FM-2027 (FM-2026)

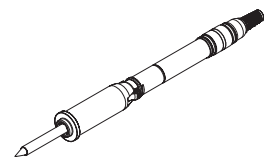

\*HAKKO FM-2027 (not included) can be connected to HAKKO FM-205.  
 \*When using above FM-2027/FM-2026 soldering iron, please use it with the dedicated iron holder.

## ● MODEL FM-2024 desoldering tool

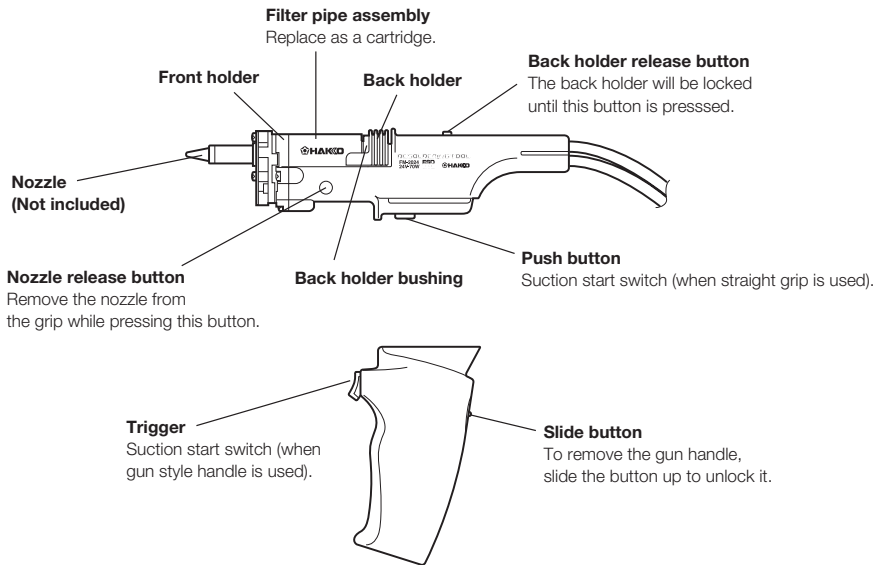

## 2. SPECIFICATIONS

### ● HAKKO FM-205 desoldering station

Power Consumption	80 W
Temperature Range	200 to 450°C (400 to 840°F)
Temperature Stability	±5°C (±9°F) at idle temperature

### ● Station

Output	24 V
Dimensions (W x H x D)	160 x 120 x 225 mm (6.3 x 4.7 x 8.9 in)
Weight	3.4 kg (7.5 lbs.)
Vacuum Generator	Ejector type
Vacuum Pressure (Max.)	93kPa (28 in. Hg)
Suction Flow	20 L/min.*
Applied Air Pressure	490 kPa (71 psi) When in use (trigger or button is pressed)
Compressed Air Consumption	46 L/min.

\* This suction flow is measured at the filter case suction port of Station.

### ● HAKKO FM-2027 (Option)

Power Consumption	70 W (24 V)
Tip to Ground Resistance	< 2 Ω
Tip to Ground Potential	< 2 mV
Total Length (w/o cord)	188 mm (7.4 in.) with 2.4D tip
Weight (w/o cord)	30 g (0.067 lb./1.07 oz.)with 2.4D tip
Cord	1.2 m (4 ft)

### ● MODEL FM-2024 desoldering tool

Power consumption	70 W (24 V)
Temperature range	350 - 450°C (650 - 840°F)
Tip to ground potential	< 2 mV
Tip to ground resistance	< 2 Ω
Length, less cord	180 mm (7.0 in.)
Weight, less cord & hose	65 g (2.3 oz.)
Length of cord	1.2 m (4 ft.)

\* The temperatures were measured using the HAKKO FG-101 soldering tester.

\* This product is protected against electrostatic discharge.

### 中國RoHS: 產品中有毒有害物質或元素的名稱及含量

部件名稱	有毒有害物質或元素					
	鉛(Pb)	汞(Hg)	鎘(Cd)	六價鉻(Cr(VI))	多溴聯苯(PBB)	多溴二苯醚(PBDE)
電路板	×	○	○	○	○	○
吸錫槍部分	×	○	○	○	○	○
插頭	×	○	○	○	○	○
插座	×	○	○	○	○	○
焊鐵座	×	○	○	○	○	○

○ : 表示該有毒有害物質在該部件所有均質材料中的含量均在SJ/T 11363-2006標準規定的限量要求以下。  
 × : 表示該有毒有害物質至少在該部件的某一均質材料中的含量超出SJ/T 11363-2006標準規定的限量要求。

### ⚠ CAUTION

This product includes such features as electrically conductive plastic parts and grounding of the handpiece and station as measures to protect the device to be soldered from the effects of static electricity. Be sure to observe the following instructions:

1. The handle and other plastic parts are not insulators, they are conductors. When replacing parts or repairing, take sufficient care not to expose live electrical parts or damage insulation materials.
2. Be sure to ground the unit during use.

\* Specifications and design are subject to change without notice.

# 3. WARNINGS, CAUTIONS, NOTES AND EXAMPLES

Warnings, cautions and notes are placed at critical points in this manual to direct the operator's attention to significant items. They are defined as follows:

 **WARNING:** Failure to comply with a WARNING may result in serious injury or death.

 **CAUTION:** Failure to comply with a CAUTION may result in injury to the operator, or damage to the items involved.

**NOTE:** A NOTE indicates a procedure or point that is important to the process being described.

**EXAMPLE:** An EXAMPLE is given to demonstrate a particular procedure, point or process.

## CAUTION

**When power is ON, tip temperatures will be between 350 and 450°C (660 - 840°F). To avoid injury or damage to personnel and items in the work area, observe the following:**

- Do not touch the tip or the metal parts near the tip.
- Do not allow the tip to come close to, or touch, flammable materials.
- Inform others in the area that the unit is hot and should not be touched.
- Turn the power off when not in use, or left unattended.
- Turn the power off when connecting the MODEL FM-2024 or storing the HAKKO FM-205.
- This appliance is not intended for use by persons (including children) with reduced physical, sensory or mental capabilities, or lack of experience and knowledge, unless they have been given supervision or instruction concerning use of the appliance by a person responsible for their safety.
- Children should be supervised to ensure that they do not play with the appliance.

**To prevent accidents or damage to the HAKKO FM-205, be sure to observe the following precautions.**

Use only filtered air. Set the input air pressure between 490 and 686 kPa (71 and 100 psi) while allowing air to flow by pulling the trigger.

- Do not use the HAKKO FM-205 for applications other than soldering or desoldering.
- Do not strike the iron against hard objects to remove excess solder. This will damage the iron.
- Do not bend or damage the control card. If the card does become damaged, do not force the card into the station slot.
- Remove power and iron cords by holding the plug – not the cord.
- Do not modify the HAKKO FM-205.
- Use only genuine Hakko replacement parts.
- Do not allow the HAKKO FM-205 to become wet, or use it with wet hands.
- Be sure the work area is well ventilated. Soldering produces smoke.
- While using the HAKKO FM-205, don't do anything which may cause bodily harm or physical damage.

# 4. INITIAL SETUP

## A. Iron holder

### ● Operation

First, remove any excess solder from the tip by thrusting the tip into the cleaning wire. (Do not wipe the tip against the wire. This may cause molten solder to spatter.)

1. Insert the holder assembly securely into the Iron holder base.
2. When the wire becomes dirty or loaded with solder, turn the wire until a clean surface is presented.
3. When changing the cleaning wire, lift the case top vertically to prevent solder debris from falling out.
4. Place the spare tips in the tip tray.

### ● Use of the sleep function

When using the sleep function, insert one end of the connecting cable into the jack at the back of the iron holder and the other end into the jack at the back of the desoldering station to connect them.

#### ⚠ CAUTION

- Be sure to turn off the power before connecting or disconnecting the connecting cable.
- Securely insert the plug all the way into the jack.

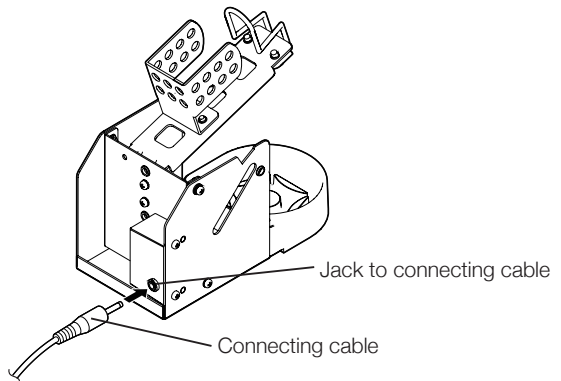
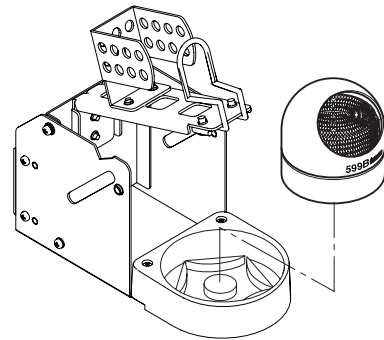

## B. MODEL FM-2024

### ● Connecting and replacing the filter pipe

Pull the back holder (a) until it locks, then insert the filter pipe assembly with the opening to the nozzle side. Ensure that the outer surface of the filter pipe assembly is even with the handle support. If the filter pipe assembly is tilted, a leak may occur.

To replace the filter pipe assembly, press back holder release button (b), pull the back holder to lock it, change the filter pipe assembly, then lock the filter pipe assembly. Replace the filter pipe assembly in the cartridge.

#### ⚠ CAUTION

The surface of the filter pipe assembly may be very hot.

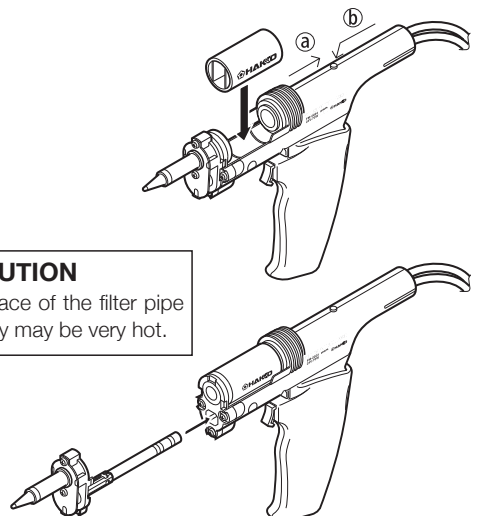

● **Attaching and replacing the nozzle cartridge**

Insert the nozzle cartridge fully into the grip as shown in the illustration. Once the nozzle cartridge is inserted, it is locked automatically.

**CAUTION**

The nozzle can be very hot. To attach or remove the nozzle cartridge, be sure to use the nozzle remover to preclude the possibility of breaking the grip or cartridge.

To replace the nozzle cartridge, insert the nozzle remover into the flange of the nozzle cartridge, press the nozzle release button **A** and remove the nozzle cartridge.

**CAUTION**

The nozzle may be very hot.

The nozzle remover may be left mounted on the end of the straight grip when not in use to prevent it from being misplaced.

● **Using the desoldering iron in the gun configuration.**

To use the desoldering iron in the gun configuration, attach the handle to the straight grip.

● **Using the desoldering iron in the pen configuration.**

To remove the handle, slide down the button located on the rear of the handle to unlock it, then slide the handle toward the back of the MODEL FM-2024.

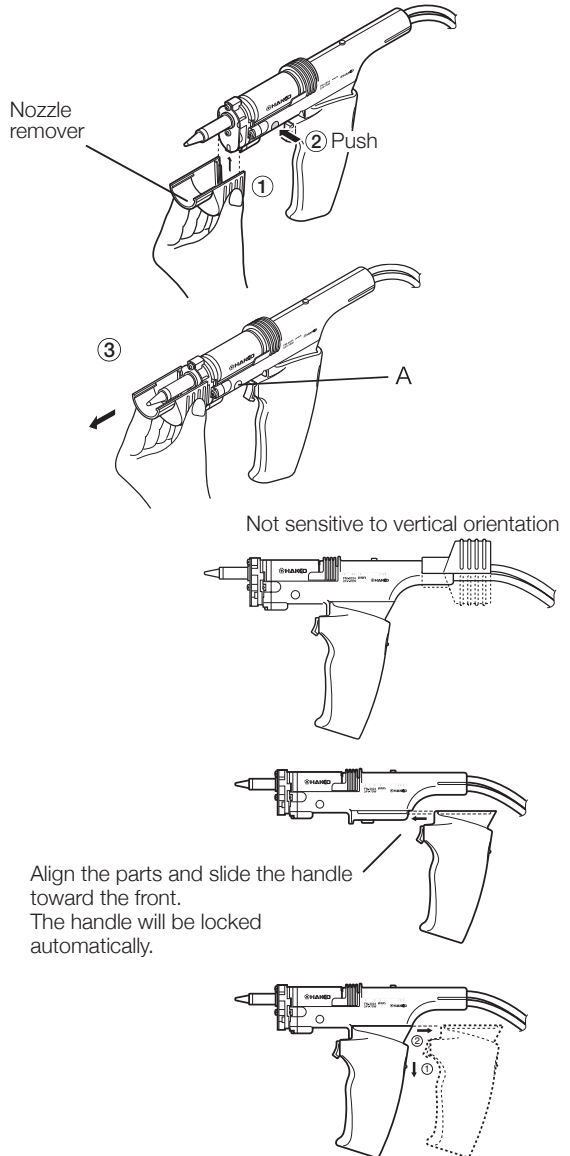

**HAKKO FM-2027 (Option)**

**Inserting the tip:**

- Holding the front end of the tip, insert it into the sleeve assembly.

**CAUTION**

Insert the tip into the sleeve assembly until it clicks into place. When you hear it clicks, avoid forcing the tip into the sleeve assembly.

- Insert the tip securely into the connector.

**NOTE:**

Improper insertion of the tip will cause **S-E** to appear on the display.

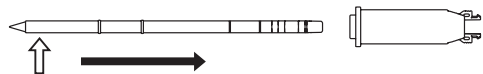

Hold this part to insert the tip into the sleeve assembly.

**CAUTION**

When holding the head of the tip, there is a danger of burn. Be sure to use the heat-resistant pad.

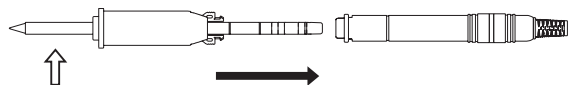

Hold this part to insert the tip into the connector.

## C. Desoldering station

### ⚠ CAUTION

- Be sure to unplug the cord by holding the plug.
- Securely insert the connecting cable all the way into the jack.

- The HAKKO FM-205 detects when the iron is removed from the iron holder and sends this data to the station via the connecting cable. That data is then used for various functions.

### ● Connection

1. Connect the power cord to the inlet on the rear of the station.

(Connect the plug from the MODEL FM-2024 to the receptacle on the HAKKO FM-205.)

### ⚠ CAUTION

Connect the plug to the receptacle, aligning the tab on the plug with the opening on the receptacle.

2. Put MODEL FM-2024 into the iron holder.
3. Connect the hose from the MODEL FM-2024 to the filter case cover on the HAKKO FM-205 Station.

4. Connect the station to the shop air supply/compressor.

Use only filtered air to eliminate the probability of dust, water, and oil content from fouling the mechanism.

Adjust the pressure to 490 kPa (71 psi) with the regulator while allowing air to flow by pressing the button (or pulling the trigger) on the handpiece.

### ⚠ CAUTION

If you attempt to adjust the pressure without allowing air to flow, or if the tube size is not as specified, the suction capability will decrease. Ensure that the regulator shows less than 882 kPa (128 psi) when the trigger is turned OFF. If pressure equal to or higher than this value is applied, damage may result.

### typical interconnection

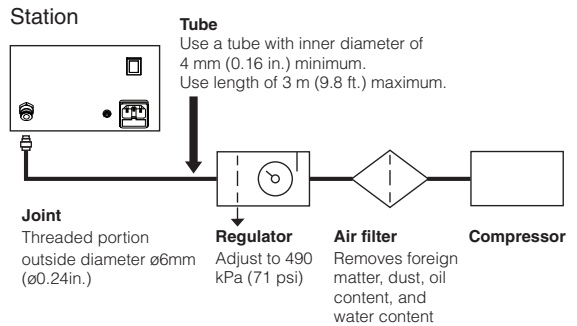

### ⚠ CAUTION

Be sure to use an air filter. Foreign matter in the piping or the air supply can jam the solenoid valve, causing a failure.

5. Plug the power cord into a grounded wall socket.

Ensure that the power switch is OFF before inserting the AC plug.

### ⚠ CAUTION

Be sure to ground this product as it is ESD safe by design.

6. Turn ON the power.

### ⚠ CAUTION

The HAKKO FM-205 does not function properly if the power is turned on with the trigger pressed. Release the trigger and then turn the power ON.

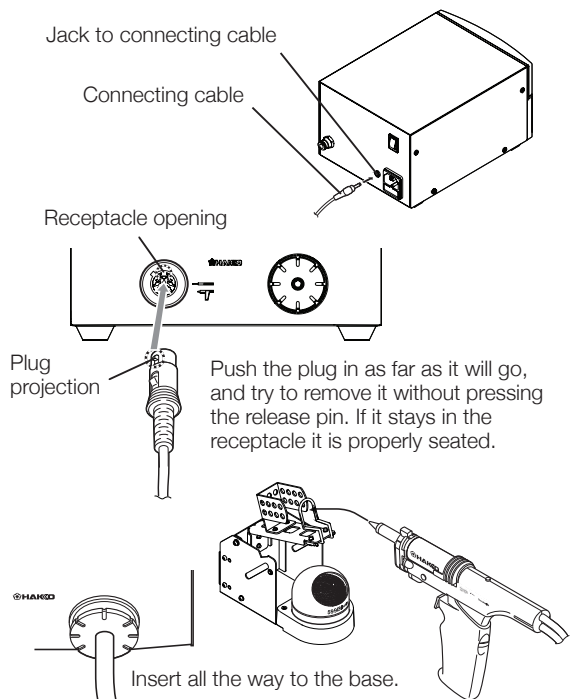

# 5. OPERATION

## Controls and displays

### Controls

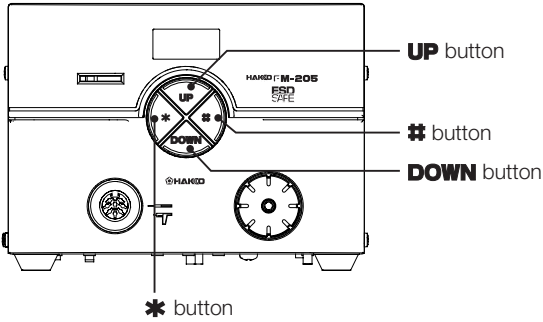

The front panel of the HAKKO FM-205 has four controls.

- \*** .....End of sequence signal (terminates a phase of a data entry mode). When pressed for less than one second, displays settings already stored.
- #** .....Initiates a data entry mode.
- UP** .....Increases the displayed value.
- DOWN** ...Decreases the displayed value.

The HAKKO FM-2027 and the MODEL FM-2024 can be connected to the HAKKO FM-205 Station.

The lamp on the grip operates as follows.

- In use ..... Lights
- Sleep mode..... Blinks slowly
- Off mode ..... Off
- Error ..... Blinks quickly

### Operation

1. Turn the power switch ON.
2. By default, when the set temperature is reached, the buzzer sounds, indicating that the unit is ready.

The heater lamp on the front panel starts blinking.

### Displays

The HAKKO FM-205 has a three-digit display element.

Depending on the selected mode, it will display:

- Sensor temperature (of the iron tip)
- Data entry:
  - Selected quantity (See the data entry procedures.)
- Temperature scale:
  - °C or °F, depending on selection
- Error detection (See ERROR MESSAGES.)

An audible buzzer is provided to alert the operator:

- When the station has reached the set temperature, the buzzer will sound once. (Default setting)
- When the low temperature threshold has been crossed, the buzzer will sound continuously. This buzzer will shutoff when the sensed temperature returns to the acceptable range.
- When a foreign substance, an incompatible tip, or the soldering end of the tip is inserted into the HAKKO FM-2027, the display will blink and the buzzer will sound continuously.
- When the auto-power shutoff function is activated and power to the heater is shut off, the buzzer sounds three times.

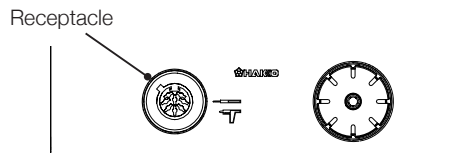

**CAUTION**  
By default, the temperature is set to 350°C (660°F). You can confirm the set temperature by pressing the \* button. The set temperature will be displayed for two seconds.

**CAUTION**  
When not in use, set the iron in the iron holder.



## ● Changing the temperature setting

### • MODEL FM-2024

#### Temperature setting range

°C.....350 to 450°C

°F.....660 to 840°F

### • HAKKO FM-2027 (Option)

#### Temperature setting range

°C.....200 to 450°C

°F.....400 to 840°F

**Example:** Changing the temperature from 350°C to 400°C

### 1. Insert the control card into the station.

- The hundreds digit of the display begins to flash. This indicates that the unit has entered the temperature setting mode and data may be entered.

### 2. Enter the hundreds digit.

- Press the **UP** or **DOWN** button to set the hundreds digit. When the desired figure is displayed, press the **\*** button. The tens digit begins to flash.

### 3. Enter the tens digit.

- Press the **UP** or **DOWN** button to set the tens digit. When the desired figure is displayed, press the **\*** button. The units digit begins to flash.

### 4. Enter the units digit.

- Set the desired units digit in the same way as for the tens digit, and then press the **\*** button. The temperature is recorded to the internal memory, and heater control begins after the new set temperature is displayed.

### To change the set temperature with the control card in the station:

#### NOTE:

If you enter a value outside the temperature setting range (see the table above), the display returns to the hundreds digit, and you have to enter a correct value.

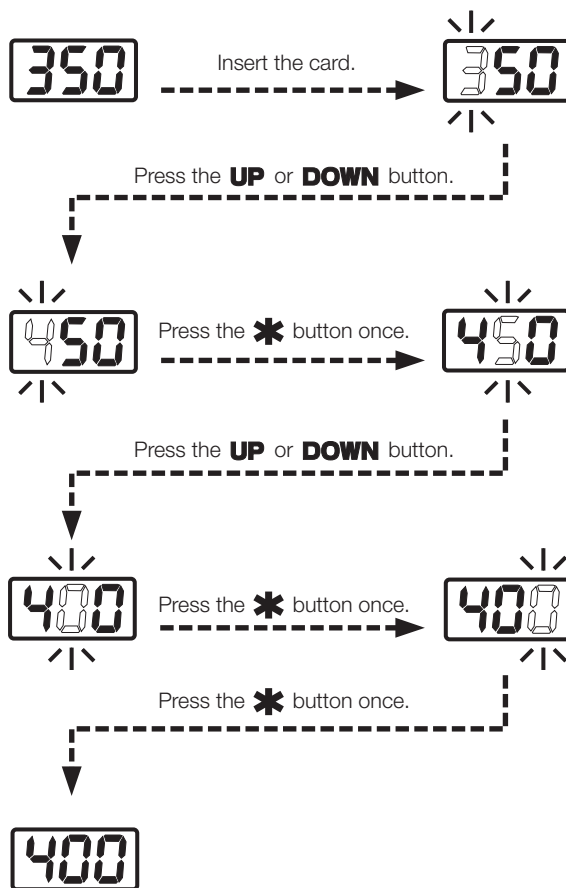

#### ⚠ CAUTION

If the power is turned off without completing the temperature setting, the new set temperature will not be recorded.

1. Press and hold the **\*** button for at least one second. The current temperature setting is displayed, and then the hundreds digit begins to flash one second later. This indicates that the station has entered the temperature setting mode. Follow steps 3 to 4 on “Changing the temperature”.
2. If the **\*** button is not pressed and held for at least one second, the current set temperature is displayed, and then the tip temperature is displayed.

The temperature accuracy of iron tips is  $\pm 15^{\circ}\text{C}$  ( $\pm 27^{\circ}\text{F}$ ) (except for designated tips) when using the default offset values. If a higher temperature accuracy is required, use the following offset function:

## ● Entering the tip offset value

### Example:

When the set temperature is  $400^{\circ}\text{C}$  and the actual tip temperature is  $410^{\circ}\text{C}$ : The difference in temperature is  $10^{\circ}\text{C}$ , so enter  $-10$  as the current offset value.

### 1. Insert the control card into the station.

- The station enters the temperature setting mode.

### 2. Press the # button.

- The station enters the offset entry mode. Press the **UP** or **DOWN** button to set the hundreds digit.

The values that can be entered in  $^{\circ}\text{C}$  or  $^{\circ}\text{F}$  are 0 (for positive values) and - (for negative values).

### 3. Select or and press the \* button.

The tens digit begins to flash. Enter the offset value.

The values that can be entered to the tens digit are 0 to 5 in  $^{\circ}\text{C}$  (0 to 9 in  $^{\circ}\text{F}$ ).

The tens and units digits are set with the offset value range.

#### Allowable offset value range

$^{\circ}\text{C}$  .....  $-50$  to  $+50^{\circ}\text{C}$   
 $^{\circ}\text{F}$  .....  $-90$  to  $+90^{\circ}\text{F}$

If you enter a value outside the allowable offset value range, the display returns to the hundreds digit, and you have to enter a correct value.

#### CAUTION

In the offset entry mode (when the display is flashing), the tip temperature is controlled by the current offset value.

### 4. Verify the tip temperature.

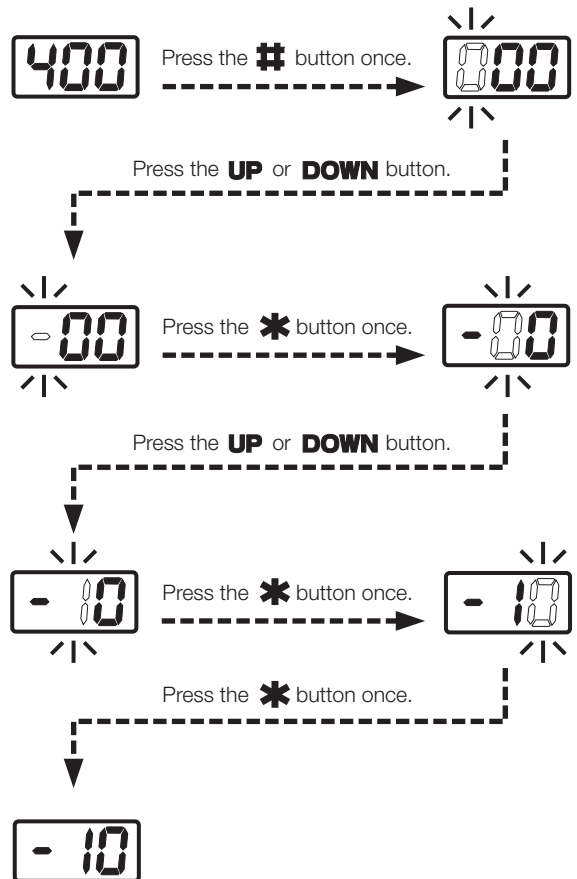

#### NOTE:

The station stores the offset values for each tip type. For example, connect the HAKKO FM-2027 to the station and enter the offset value ( $-10^{\circ}\text{C}$ ). Next, change to the MODEL FM-2024 and enter the offset value  $-20^{\circ}\text{C}$ . When you reconnect the HAKKO FM-2027, the offset value is set to  $-10^{\circ}\text{C}$  automatically.

**To change the offset value with the control card in the station:**

## ● Removing solder

### Clean the nozzle tip.

Be sure the nozzle tip is tinned with clean, fresh solder.

**If the nozzle tip is coated with oxidation or contamination, its thermal conductivity deteriorates. In contrast, if the nozzle end is wetted with a small amount of clean solder, its thermal conductivity increases.**

### 1. Melt the solder.

Position the nozzle above the lead to be desoldered as shown in the illustration and melt the solder.

#### ⚠ CAUTION

Never allow the nozzle to touch the board itself.

Confirm that the solder is melted.

#### ⚠ CAUTION

To confirm that all solder is melted, observe the inside of the hole and the backside of the P.W.B. If this is difficult to do, try slowly moving the lead with the nozzle. If the lead moves, the solder is melted. Never move the lead by force. If it doesn't move easily, the solder isn't yet fully melted.

### 2. Extract the solder.

After confirming that the solder is completely melted, extract the solder by pressing the button (or squeezing the trigger).

#### ⚠ CAUTION

Never leave any solder remaining inside the hole in the P.W.B.

### 3. Problems during desoldering.

If solder remains, resolder the component and repeat the desoldering process.

### 1. Press and hold the **⏏** button for at least one second.

The current offset value is displayed, and then the hundreds digit begins to flash one second later. This indicates that the station has entered the offset entry mode. Follow steps 3 and 4 for setting the offset value of the tip temperature.

### 2. If the **⏏** button is not pressed and held for at least one second, the current OFF set value is displayed, and then the temperature setting is displayed.

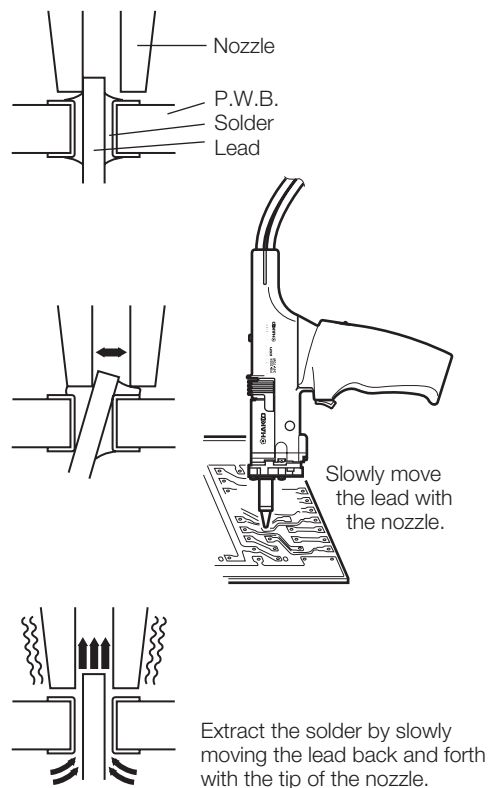

# 6. PARAMETER SETTINGS

## ● Parameter entry mode process

Select the parameter entry mode using the following operation.

Be sure to insert the control card before opening.

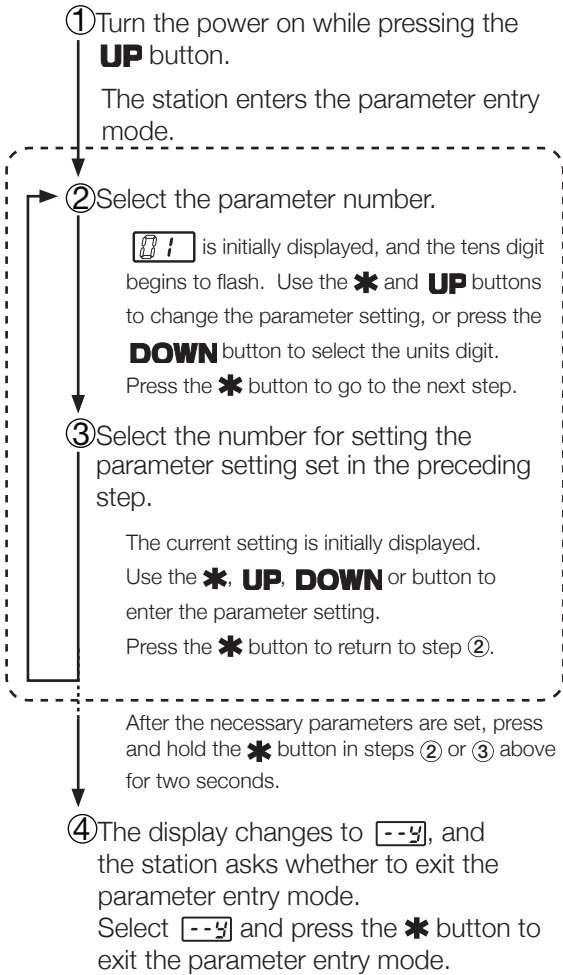

The HAKKO FM-205 has the following parameters.

	Number	LED display	Setting	Default setting
Temperature display	01	F or C	F: °F display C: °C display	°F display
Auto sleep time setting	02	Tens digit entry	Sleep time	6 min.
Low temperature error setting	03	Hundreds digit entry	Low temperature threshold entry	270°F
Offset-free mode	04	0 or 1	0: Off 1: On	Off (0)
Buzzer setting (C-E sound, S-E sound)	05	0 or 1	0: Off 1: On	On (1)
Buzzer setting (Set temperature alert)	06	0 or 1	0: Off 1: On	On (1)
Auto sleep on/off setting	07	0 or 1	0: Off 1: On	On (1)
Auto shutoff on/off setting	08	0 or 1	0: Off 1: On	Off (0)

**NOTE:**

- Each time the **UP** or **DOWN** button is pressed, the display toggles between the following displays: --y and --n.
- When --n is selected, the parameter number selection screen in step 2 is displayed.

**CAUTION**

Do not leave the HAKKO FM-205 for a long time with the auto shutoff function activated. Turn the power off when you do not use the HAKKO FM-205 for a long time.

## ● 0 1: Temperature display (°C or °F)

- When the display changes to F and C, the station enters the mode for changing the temperature display.
- Press the **UP** or **DOWN** button to switch the display alternately between F (Fahrenheit) and C (Celsius).

## ● 02 : Auto sleep time setting

Set the time until the auto sleep function activates after the soldering iron is set on the iron holder.

### Auto sleep examples:



Sleep (immediately after the iron is set on the iron holder)



Sleep (10 minutes after the iron is set on the iron holder)

### NOTE:

- The auto sleep time can be set in units of minutes (up to 29 minutes).

- The tip temperature is reduced to approximately 200°C (400°F) during sleep mode. The tip temperature varies significantly, depending on the ambient environment, tip type and iron types. 200°C (400°F) should only be used as a guide.
- When the display is **SLP**, press the **UP** or **DOWN** button, or remove the soldering iron from the iron holder to resume power to the heater.

## ● 03 : Lower temperature error setting

### Lower temperature error

- When the temperature drops below a set limit, an error is displayed and the buzzer sounds.
- When the temperature returns within the allowable range, the buzzer stops.

### Low temperature setting range

for Celsius: 30 to 150°C  
for Fahrenheit: 50 to 300°F

### Example:

When the set temperature is 350°C and the low temperature error setting is 100°C, a warning buzzer sounds when the temperature drops to 250°C.

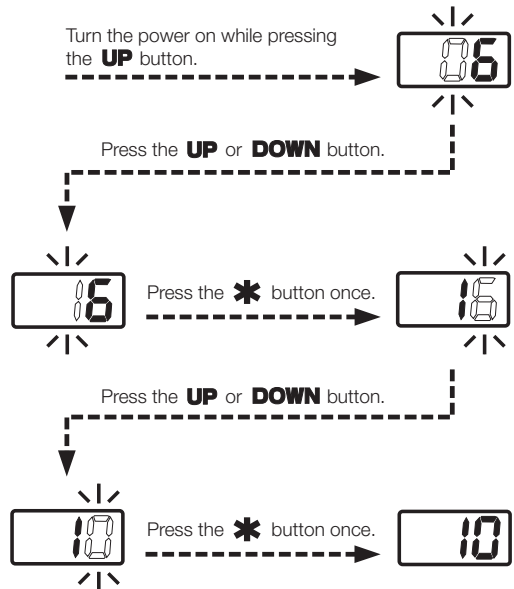

### ⚠ CAUTION

- When the setting temperature is 300°C (570°F) or less, the sleep function cannot be set to Sleep even if the sleep function is set to ON.
- The tip temperature rises to the setting temperature once at power on even if the sleep time is set to "0". The tip temperature will be reduced to the sleep temperature after the temperature reaches the set temperature.

- The hundreds digit begins to flash when entering the low temperature setting. Use the method for setting the temperature to enter and set the low temperature setting.
- If you enter a value outside the low temperature setting range (see the table on the left), the display returns to the hundreds digit, and you have to enter a correct value.
- After the low temperature setting is set, the display returns to the parameter number selection screen.

## ● 04 : Offset-free mode

## ● 05 : S-E, C-E buzzer sound setting mode

## ● 06 : Set temperature alert setting mode

## ● 07 : Auto sleep function setting mode

### NOTE:

When the auto sleep function is on, removing the iron from the iron holder or pressing the **UP** or **DOWN** button resumes operations.

## ● 08 : Auto shutoff function setting mode

When the soldering iron is set on the iron holder and is not operated for 30 minutes, power to the heater is shut off automatically, and the unit shuts off.

When the auto shutoff function is on, removing the iron from the iron holder or pressing the **UP** or **DOWN** button resumes operation.

When auto shut-off is activated, the buzzer sounds, and it sounds again in 30 minutes.

- When the station is in the offset-free mode, either  0 or  1 is displayed.

0 : The offset value cannot be entered without the control card inserted into the station.

1 : The offset value can be entered without the control card inserted into the station.

Select **UP** or **DOWN** and press the **\*** button.

- In the buzzer sound setting mode, which sets whether to sound the buzzer when a sensor error or soldering iron error occurs either

0 or  1 is displayed.

0 : The buzzer does not sound.

1 : The buzzer sounds.

Select **UP** or **DOWN** and press the **\*** button.

- In the set temperature alert setting mode, either  0 or  1 is displayed.

0 : The buzzer does not sound when the soldering iron reaches the set temperature.

1 : The buzzer sounds when the soldering iron reaches the set temperature.

Select **UP** or **DOWN** and press the **\*** button.

- In the auto sleep setting mode, either  0 or  1 is displayed.

0 : The auto sleep function is off, regardless of the auto sleep set time.

1 : The auto sleep function is on, and the auto sleep time is activated.

Select **UP** or **DOWN** and press the **\*** button.

- In the auto shutoff setting mode, either  0 or  1 is displayed.

0 : The auto shutoff function is turned off.

1 : The auto shutoff function is turned on.

Select **UP** or **DOWN** and press the **\*** button.

# 7. MAINTENANCE

Properly maintained, the MODEL FM-2024 desoldering tool should provide years of good service. Efficient desoldering depends upon the temperature, and the quality and quantity of the solder and flux. Perform the following service procedures as dictated by the conditions of usage.

## ⚠ WARNING

Since the desoldering tool can reach a very high temperature, please work carefully. Except when cleaning the nozzle and heating element, ALWAYS turn the power switch OFF and disconnect the power plug before performing any maintenance procedure.

### Maintenance of nozzle

#### ⚠ CAUTION

The desoldering tool may be extremely hot. During maintenance, please work carefully.

### Inspect and clean the nozzle

- Plug in the power cord, turn the power switch ON and let the nozzle heat up.

#### ⚠ CAUTION

The cleaning pin will not pass through the nozzle until the solder inside the nozzle is completely melted.

- Clean out the hole of the nozzle with the nozzle cleaning pin (not included as a standard accessory).
- If the cleaning pin does not pass through the hole in the nozzle, clean with the cleaning drill (not included as a standard accessory).
- Check the condition of the solder plating on the nozzle tip.
- Check visually if the nozzle was eroded.

#### ⚠ CAUTION

The inside hole and the surface of the nozzle is plated with a special alloy. Should this alloy become eroded by high-temperature solder, the nozzle will not be able to maintain the proper temperature.

- If the nozzle is still in a good condition, put some fresh solder on the nozzle tip to protect solder plated area from oxidation.

#### Cleaning with the nozzle cleaning pin

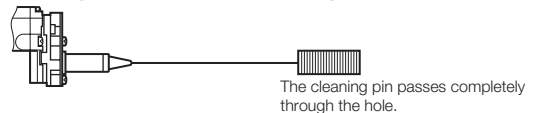

#### Cleaning with the cleaning drill

- Before cleaning

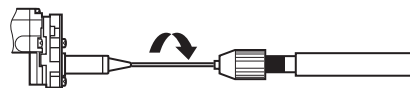

- After cleaning

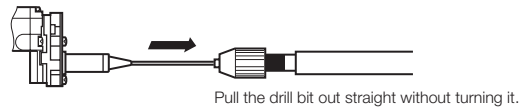

#### ⚠ CAUTION

If the cleaning drill is forced into the nozzle, the drill bit could break or be damaged. Please use the proper size cleaning pin or cleaning drill for the nozzle diameter.

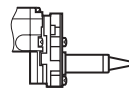

#### Solder plating

- If the cleaning pin and cleaning drill do not pass through the hole in the nozzle, replace the nozzle.
- If the solder plating on the nozzle tip is worn, replace the nozzle.
- If the inside hole of the nozzle is eroded, replace the nozzle.

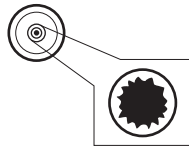

#### Hole is damaged by erosion.

#### NOTE:

Unfortunately, it is often difficult to observe this condition. Therefore, if desoldering efficiency goes down and all other parts appear to be OK, the nozzle is probably eroded and should be replaced.

## Cleaning the inside of suction pipe

Move the nozzle cartridge to the cleaning position indicated in figure at right. Change the position of the nozzle cartridge before turning the power ON, to prevent accidents.

To clean the inside of the suction pipe, ensure that the solder remaining in the pipe has been completely melted.

For the cleaning of the suction pipe, set the nozzle temperature to 400°C/750°F or higher. Start this cleaning after the set temperature has been reached.

To clean the inside of the suction pipe, insert the cleaning drill fully into the suction pipe while turning it clockwise. Then remove the accumulated debris.

## Check and clean the front and back holder bushings

If foreign matter gets stuck on the contact surface between the front holder and the filter pipe assembly, or between the back rubber holder bushing and the filter pipe assembly, air will be sucked into the tool, preventing normal desoldering. Remove the solder and flux adhering to the surface of front holder **a** and back holder **b** then connect the filter pipe assembly.

**CAUTION**  
First remove the nozzle from the grip while pressing the nozzle release button, then insert the nozzle as shown.

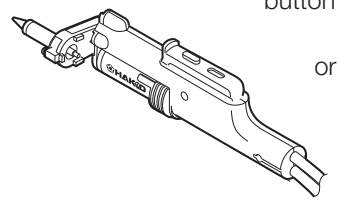
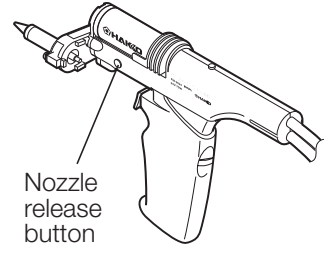

**CAUTION**  
If you insert the drill without turning it or if you try to insert the drill at an angle, the nozzle cartridge may be broken.

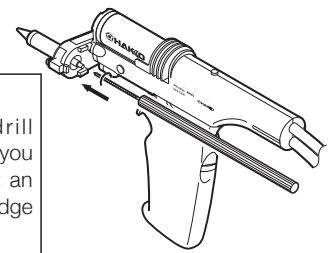

**CAUTION**  
When removing the cleaning drill, keep it parallel with the nozzle. If it is difficult to remove the drill, turn it slightly whilst withdrawing it. If you forcibly remove the drill, the cartridge may be broken.

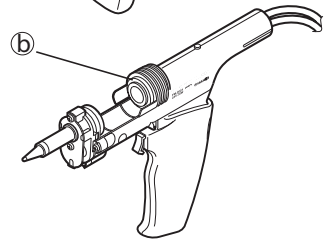
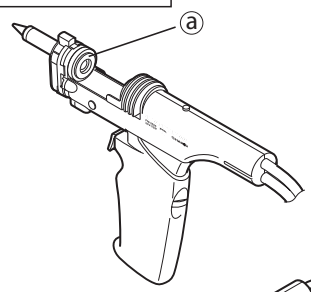
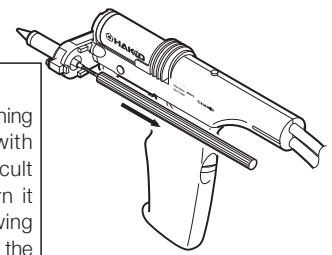



## Checking and replacing the ceramic paper filter

The filter is clogged with hardened flux.

Fit the filter case cover in place.

1. Turn the filter case cover on the HAKKO FM-205 station counterclockwise to unlock it, then remove the cover by pulling it straight out.

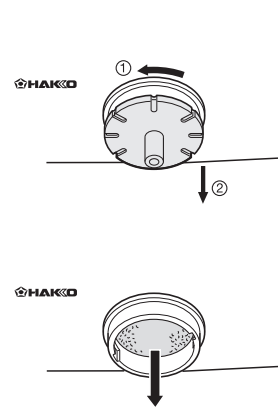

2. Replace the ceramic paper filter.

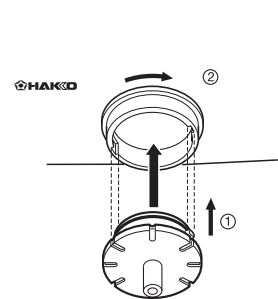

3. After replacing the ceramic paper filter, press the filter case cover with its tabs inserted into the corresponding slots in the filter case then turn clockwise to lock it.

# Cleaning the ejector

**⚠ WARNING**  
**Unplug the power cord before cleaning the ejector.**

**NOTE:**  
 Cleaning the ejector should only be performed if the suction is low and you have

- replaced the ceramic paper filter
- ensured the nozzle and hose are clear of any obstructions

## 1) Disassembly

1. Remove the screws (8) used to secure the cover, and remove the cover.

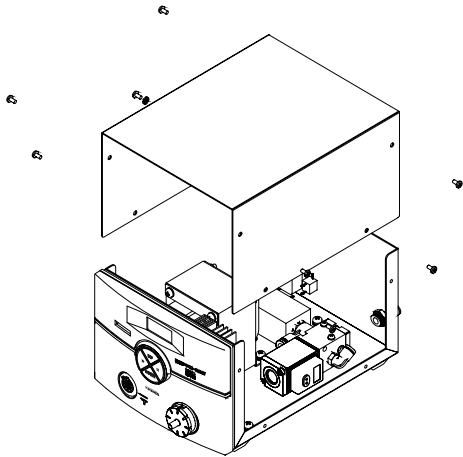

**⚠ CAUTION**  
 Please make sure to disconnect from the compressed air before you start cleaning. If you clean the ejector with the compressed air still connected, the compressed air may cause the nozzle and exhaust pipe to suddenly fly off when the ejector cover is removed.

2. Remove the exhaust filter which covers the ejector.

**NOTE:**  
 Replace it if it is dirty.

3. Remove the ejector cover.

**NOTE:**  
 If the noise filter inside the cover is very dirty, replace it.

4. Remove the exhaust pipe and spacer from inside the ejector.  
 Pinch the tip of the exhaust pipe and pull firmly. It can be removed together with the spacer.

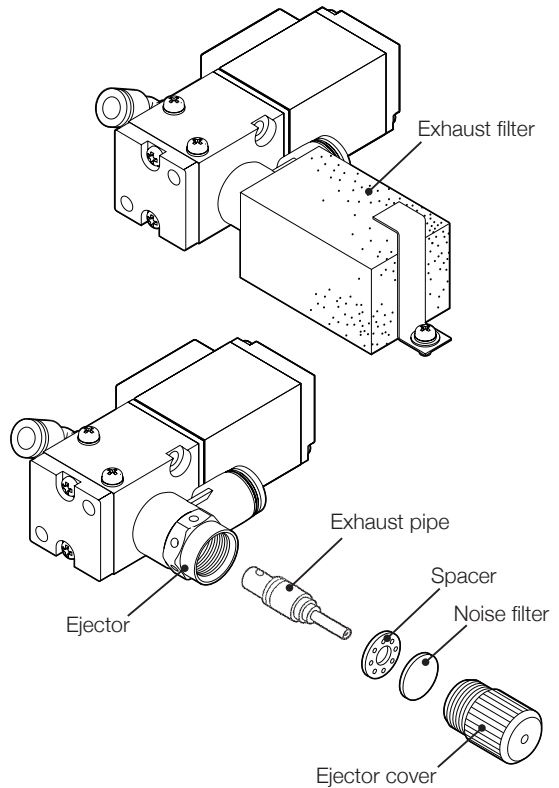

## 2) Cleaning the inside

**⚠ CAUTION**  
 Do not use thinner as a cleaning agent.

1. Clean the inside of the ejector, the tip of the nozzle and the surrounding area. Remove any dirt with a cotton swab soaked in alcohol.
2. Soak the exhaust pipe in alcohol and clean the inside of the pipe with a soft pipe cleaner.

### Inside of the ejector

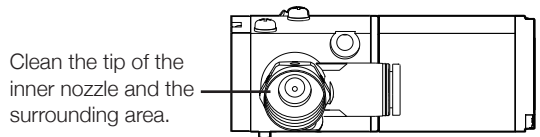

### Exhaust pipe

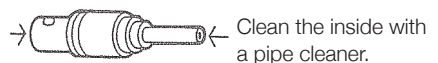

## 3) Reassemble in reverse order.

## ● Checking procedure

### WARNING

Unless otherwise specified, perform the following steps after turning the power switch OFF and disconnecting the AC plug.

### ■ Checking the cord assembly

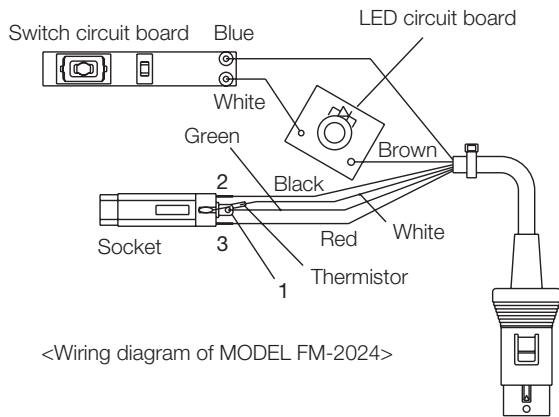
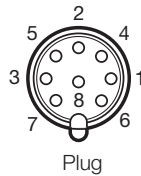

Checking the electrical continuity of the cord assembly

1. Remove the plug of the cord assembly from the station.
2. If the handle is attached, remove it.
3. Remove the nozzle cartridge. For this removal, see “Attaching and replacing the nozzle cartridge.”
4. Remove the screws for the grip and measure the resistance between the socket terminal and the connector pin as shown below (refer to the wiring diagram).

- Plug 1 ..... Red (socket) 3
- Plug 2 ..... Green (socket) 1
- Plug 3 ..... Black (socket) 2
- Plug 4 ..... Brown (LED circuit board)
- Plug 5 ..... White (thermistor)
- Plug 6 ..... Blue (switch circuit board)

If the resistance is larger than  $0 \Omega$  or  $\infty$  in any location, replace the cord assembly.

### ■ Checking the grounding line

1. Measure the resistance between plug pin 2 and the nozzle end.
2. If the resistance value exceeds  $2 \Omega$  (at room temperature), perform the maintenance for the tip, which is described in the next page. If this does not decrease the value, check the electrical continuity of the cord assembly.

## ■ Maintenance

This procedure, if followed daily, will materially add to tip life.

- a. Set the temperature to 250°C (482°F).
- b. When the temperature stabilizes, clean the tip and check the condition of the tip. If the tip is badly worn or deformed, replace it.
- c. If the solder plated part of the tip is covered with black oxide, apply fresh solder, containing flux, and clean the tip again. Repeat until all the oxide is removed, then coat the tip with fresh solder.

**⚠ CAUTION**

NEVER file the tip to remove oxides!

- d. Turn the power OFF and remove the tip, using the heat resistant pad. Set the tip aside to cool.
- e. Remaining oxides, such as the yellow discoloration on the tip shaft, are not harmful but, can be removed with isopropyl alcohol.

## ■ Checking the heater/sensor

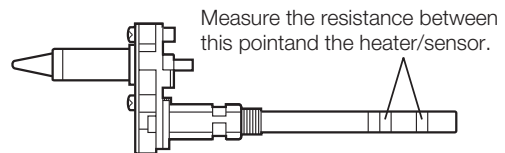

Measure the resistance at room temperature (15 to 25°C ; 59 to 77°F). The normal range is  $8\Omega \pm 10\%$ . If the resistance is outside this range, replace the nozzle assembly.

# 8. ERROR MESSAGES

## ● Sensor Error



## ● Low-temperature alarm tolerance error

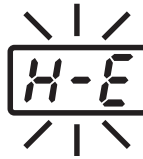

### EXAMPLE:

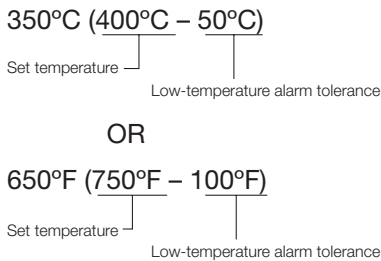

## ● Heater terminal short circuit error



## ● Soldering iron error



When there is the possibility that a failure has occurred in the sensor or heater (including the sensor circuit), **S-E** is displayed and the power is shut down.

### NOTE:

The sensor error also occurs if the tip is not inserted properly. When a grip is connected, **S-E** may be displayed momentarily. This does not indicate a malfunction.

If the sensor temperature falls below the difference between the current temperature setting and the low-temperature alarm tolerance, **H-E** is displayed and the warning buzzer sounds. When the tip temperature rises to a value within the set tolerance, the buzzer will stop sounding.

### EXAMPLE:

Assume that the temperature setting is 400°C/750°F and the tolerance 50°C/100°F. If the temperature continues to decrease and finally falls below the value indicated below while the heating element is on, the displayed value starts blinking to indicate that the tip temperature has dropped.

**HSE** will flash, and the buzzer will sound continuously, when the tip is inserted incorrectly, an incompatible tip is inserted, or a foreign object has found its way into the connector.

**I-E** will be displayed if the connector cord is not attached to the station or the wrong soldering iron is connected.

# 9. TROUBLESHOOTING GUIDE

## WARNING

To check inside or replace parts, be sure to turn the power switch OFF and remove the AC plug to avoid electric shock.

● No operation occurs when the power switch is turned ON.

**CHECK** : Is the power cord connected properly?

**ACTION** : Properly connect the power cable.

**CHECK** : Is the fuse blown out?

**ACTION** : Investigate why the fuse blew and then replace the fuse. If the cause can not be determined, replace the fuse. (e.g., short-circuit in the desoldering iron)

● When the power switch is turned ON, soldering iron error is displayed.

**CHECK** : Is MODEL FM-2024 connected?

**ACTION** : Connect MODEL FM-2024.

**CHECK** : Is the cord assembly connected properly?

**ACTION** : Connect again while referring to "INITIAL SETUP".

**CHECK** : Is the cord assembly broken?

**ACTION** : Refer to "Checking the electrical continuity of the cord assembly" in Maintenance.

● The nozzle is not heated.

**CHECK** : Is the nozzle cartridge fully inserted?

**ACTION** : Fully insert the nozzle cartridge.

**CHECK** : Is the cord assembly broken? Is the heater/sensor disconnected?

**ACTION** : Refer to "Checking the electrical continuity of the cord assembly" and "Checking the heater/ sensor" in Maintenance.

● The nozzle end does not extract solder.

**CHECK** : Is the set temperature for the nozzle too high?

**ACTION** : Set the nozzle temperature at the appropriate level.

**CHECK** : Is the nozzle end plugged or coated with oxide?

**ACTION** : Remove the oxide by cleaning the nozzle end with cleaning sponge or tip cleaner.

**CHECK** : Has the nozzle end deteriorated due to corrosion?

**ACTION** : Replace the nozzle.

● The tip temperature is too high.

**CHECK** : Is the connection cord broken?

**ACTION** : See "Checking the electrical continuity of the cord assembly".

● The tip temperature is too low.

**CHECK** : Is the nozzle end plugged or coated with oxide?

**ACTION** : Remove the oxide by cleaning the nozzle end with HAKKO 599B Tip cleaner.

**CHECK** : Has the nozzle end deteriorated due to corrosion? □

**ACTION** : Replace the nozzle.

**CHECK** : Verify the tip offset value is correct.

**ACTION** : Enter the correct value.

● **The low-temperature alarm tolerance error  $H-E$  occurs frequently.**

**CHECK** : Is the setting value for the low-temperature alarm tolerance too low?

**ACTION** : Increase the setting value.

● **Heater terminal short circuit error  $HSE$  is displayed.**

**CHECK** : Is the nozzle cartridge for MODEL FM-2024?

**ACTION** : Turn the power switch OFF and insert the MODEL FM-2024 tip. Turn the power switch ON.

● **Solder cannot be removed.**

**CHECK** : Is the heat insufficient?

**ACTION** : Higher heat may be required for large projects. Perform soldering operation while preheating the work. Increasing the nozzle temperature indiscriminately can damage the work. Use an appropriate temperature.

**CHECK** : Is it difficult for solder to stay on the nozzle tip?

**ACTION** : See "Maintenance of nozzle" and "The nozzle end does not extract solder".

● **Suction power is dropping.**

**CHECK** : Is oxide adhering to the nozzle or inside the suction pipe?

**ACTION** : See "Maintenance of nozzle" and "Cleaning the inside of suction pipe".

**CHECK** : Is a piece of removed solder stuck in the filter pipe?

**ACTION** : If removed solder is clogging up 70 to 80 percent of the filter pipe, replace the filter pipe. Also replace the filter pipe after suctioning large amounts of flux or when the ceramic filter hardens.

**CHECK** : Is solder residue stuck between the front holder or back holder bushing and the contact surface of the filter pipe assembly?

**ACTION** : See "Check and clean the front and back holder bushings".

**CHECK** : Has the ceramic paper filter deteriorated?

**ACTION** : The ceramic paper filter is full of flux, thereby reducing the suction power. See "Checking and replacing the ceramic paper filter".

# 10. PARTS LIST

**NOTE:**  
Spare or repair parts do not include mounting screws, if they are not listed on the description. Screws must be ordered separately.

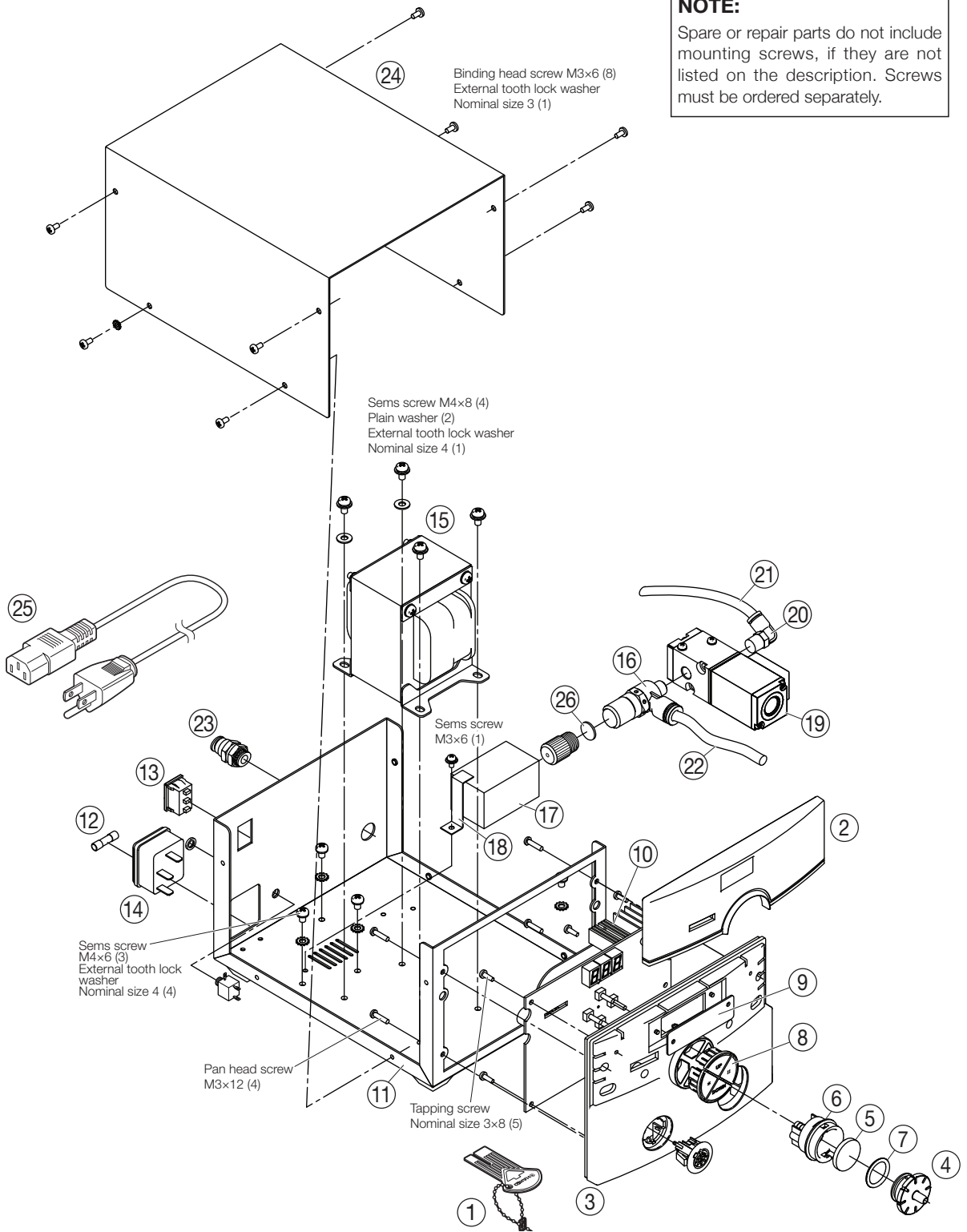



## ● HAKKO FM-205 Station

Item No.	Part No.	Part Name	Specifications
①	B2972	Card	
②	B3445	Front panel A	
③	B3416	Front panel B	
④	B2880	Vacuum outlet cap	With O-ring
⑤	A1514	Ceramic paper filter	10 pcs.
⑥	B3752	Filter case	
⑦	B2954	O-ring/Filter case cover	
⑧	B3419	Button set	4 pcs.
⑨	B3401	Display	
⑩	B3446	P.W.B	
⑪	B3449	Chassis	With rubber feet
⑫	B2761	Fuse/250V-3A	100-120V
⑬	B2852	Switch	
⑭	B2384	Power receptacle	
⑮	B3421	Transformer/100V	
	B3423	Transformer/120V	
⑯	B1069	Ejector	
⑰	B1070	Exhaust filter	
⑱	B1071	Exhaust filter retaining clip	
⑲	B2962	Solenoid valve	
⑳	B1075	Elbow joint	
㉑	B3447	Pressure hose	
㉒	B3448	Inner hose/8mm x 150L	
㉓	B2965	Joint	
㉔	B3431	Cover	
㉕	B2419	Power cord, 3 wired cord & American plug	
㉖	B1269	Noise filter	

## ● Desoldering tool

Item No.	Part No.	Part Name	Specifications
① - ⑥, ⑧	FM2024-02	Desoldering tool	24V, 70W
①	A1512	Front holder	
②	A1511	Filter pipe assembly	Set of 10
③	A1513	Back holder bushing	
④	B2878	Back holder	
⑤	B2877	Hose	
⑥	B2879	Flange	
⑦		Nozzle	See parts list for nozzle.
⑧	B2872	Handle	For gun configuration
⑨	B2873	Cleaning drill	For heating element
⑩	B2876	Nozzle remover	

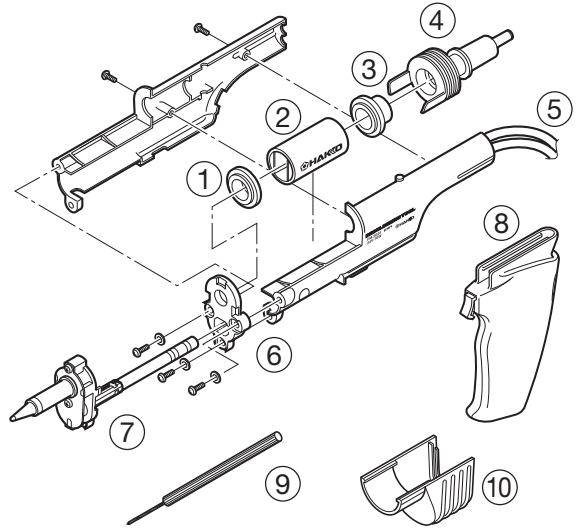

## ● Nozzle

Item No.	Part Name	øA	øB
N3-06	Nozzle 0.6 mm (0.02 in.)	0.6 mm (0.02 in.)	1.9 mm (0.07 in.)
N3-08	Nozzle 0.8 mm (0.03 in.)	0.8 mm (0.03 in.)	2.0 mm (0.08 in.)
N3-10	Nozzle 1.0 mm (0.04 in.)	1.0 mm (0.04 in.)	2.2 mm (0.09 in.)
N3-13	Nozzle 1.3 mm (0.05 in.)	1.3 mm (0.05 in.)	2.6 mm (0.10 in.)
N3-16	Nozzle 1.6 mm (0.06 in.)	1.6 mm (0.06 in.)	3.0 mm (0.12 in.)
N3-20	Nozzle 2.0 mm (0.08 in.)	2.0 mm (0.08 in.)	3.4 mm (0.13 in.)
N3-23	Nozzle 2.3 mm (0.09 in.)	2.3 mm (0.09 in.)	3.8 mm (0.15 in.)

Item No.	Part Name	øA	øB
N3-L10	Long nozzle 1.0 mm (0.04 in.)	1.0 mm (0.04 in.)	2.3 mm (0.09 in.)

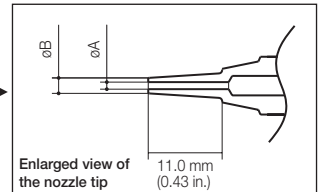
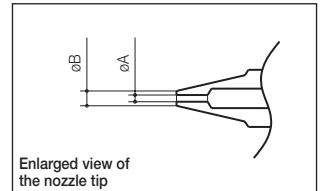
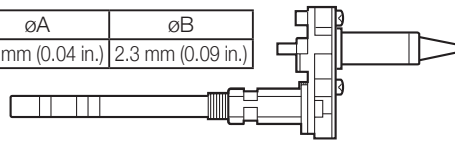

## ● Iron Holder

Item No.	Part No.	Part Name	Specifications
① - ⑦	FH200-05	HAKKO FH-200	With tip cleaner
①	B3251	Iron holder base	With rubber feet
②	B3249	Cleaner base	with rubber feet
③	599B-02	Tip cleaner	
④	599-029	Cleaning wire	
⑤	B3413	Iron holder assembly	With screws
⑥	B3250	Stay	
⑦	B3252	Switch case assembly	
⑧	B3253	Connecting cable	
⑨	B2756	Tip tray	

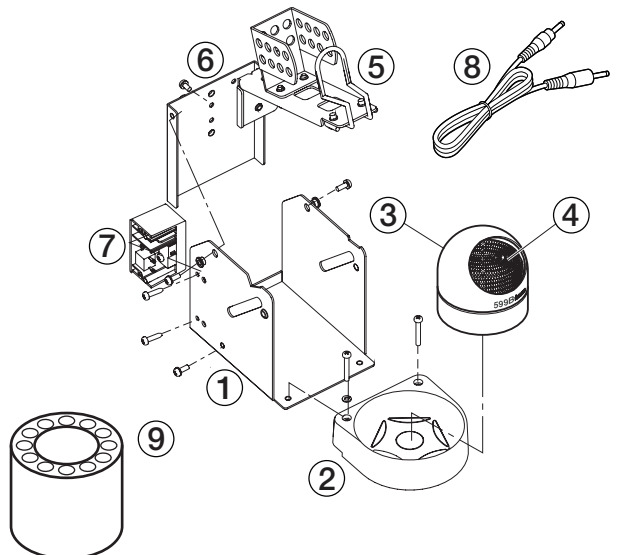

## ● Option

Part No.	Part Name	Specification
B3216	Sleeve assembly	Yellow
B3217	Sleeve assembly	Orange
B3218	Sleeve assembly	Blue
B3219	Sleeve assembly	Green
B3215	Connector cover	
B2874	Cleaning pin	For ø0.6mm (0.02 in.) nozzle
B1086	Cleaning pin	For ø0.8mm (0.03 in.) nozzle
B1087	Cleaning pin	For ø1.0mm (0.04 in.) nozzle
B1088	Cleaning pin	For ø1.3mm (0.05 in.) nozzle
B1089	Cleaning pin	For ø1.6mm (0.06 in.) nozzle
B2875	Cleaning pin	For ø2.0mm (0.08 in.)/ø2.3mm (0.09 in.) nozzle
B2300	Heat resistant pad	
FH200-01	Iron holder	With 599B
FH200-02	Iron holder	With cleaning sponge

FM2027-02	Connector assembly	
FM2027-03	Conversion kit	With 599B *1

FM2026-06	Conversion kit	*2
-----------	----------------	----

\*1: With a sleep mode iron holder, connecting cable, heat resistant pad, 599B  
 \*2: With a sleep mode iron holder, connecting cable, heat resistant pad, 599B

The FM-2026 must be used with the FX-780/FX-791.

\* Please refer to the brochure for tip variation of HAKKO FM-2027/FM-2026.

## 11. WIRING DIAGRAM

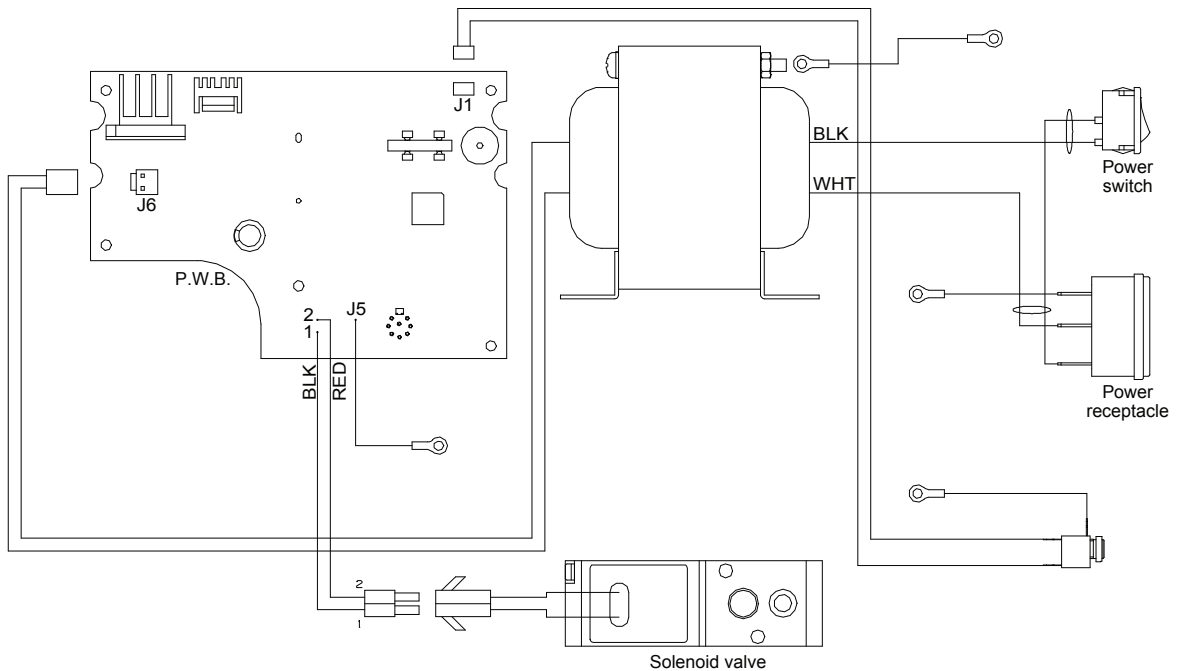



**HAKKO CORPORATION**

**HEAD OFFICE**

4-5, SHIOKUSA 2-CHOME, NANIWA-KU, OSAKA, 556-0024 JAPAN

TEL:+81-6-6561-3225 FAX:+81-6-6561-8466

<http://www.hakko.com> E-mail:[sales@hakko.com](mailto:sales@hakko.com)

**AMERICAN HAKKO PRODUCTS, INC.**

28920 AVENUE WILLIAMS VALENCIA CA 91355, U.S.A.

TEL: (661) 294-0090 FAX: (661) 294-0096

Toll Free (800)88-HAKKO [www.HakkoUSA.com](http://www.HakkoUSA.com)

4 2 5 5 6