



Quality Products. Service Excellence.

Polycarbonate Inspection Window Kit *PJHMICX Series*

Features



- Clear polycarbonate thermoplastic.
- Provides visibility and easy viewing access to equipment and components installed in an enclosure.
- Recognized UL component for use with enclosures rated NEMA Types 1, 3, 3R, 4, 4X, 12 or 13.
- CSA listed NEMA Type 1, 3, 3R, 4, 4X, 12 or 13
- UV stabilized for outdoor use.
- Formed-In-Place (FIP) polyurethane gasket in continuous channel.
- Designed for use with wall thicknesses from 16 gauge through 1/4"
- #10-32 threaded brass inserts with plated steel mounting fasteners
- Service temperature -31°F (-35°C) to 266°F (130°C)

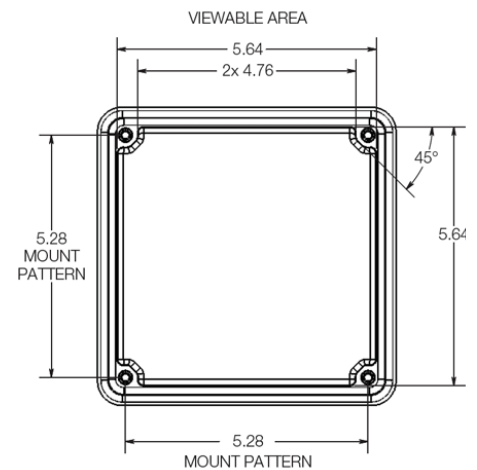
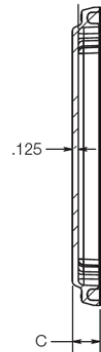
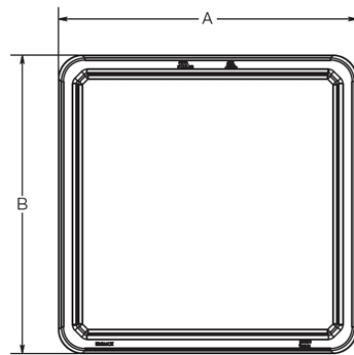

Part No.	Overall Dimensions			Viewing Area	
	A	B	C	D	E
PJHMI66CX	6.50	6.50	0.60	5.64	5.64
PJHMI95CX	10.00	7.25	0.60	9.14	6.39
PJHMI138CX	14.70	9.70	0.60	13.84	8.84

Data subject to change without notice

