

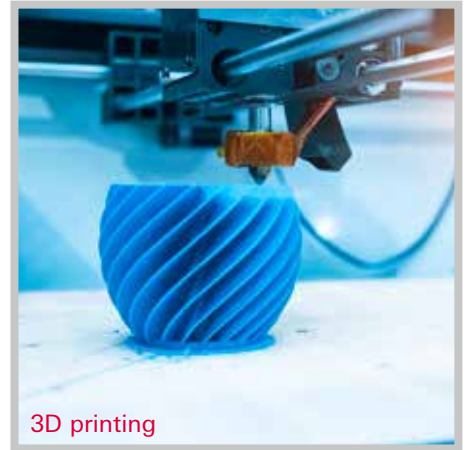

HiScroll®

The extremely quiet, efficient, oil-free pumps that reduce your CO₂ footprint.



3D printing



Mass Spectrometry



Accelerator

HiScroll®

The extremely quiet, efficient, oil-free pumps that reduce your CO₂ footprint.

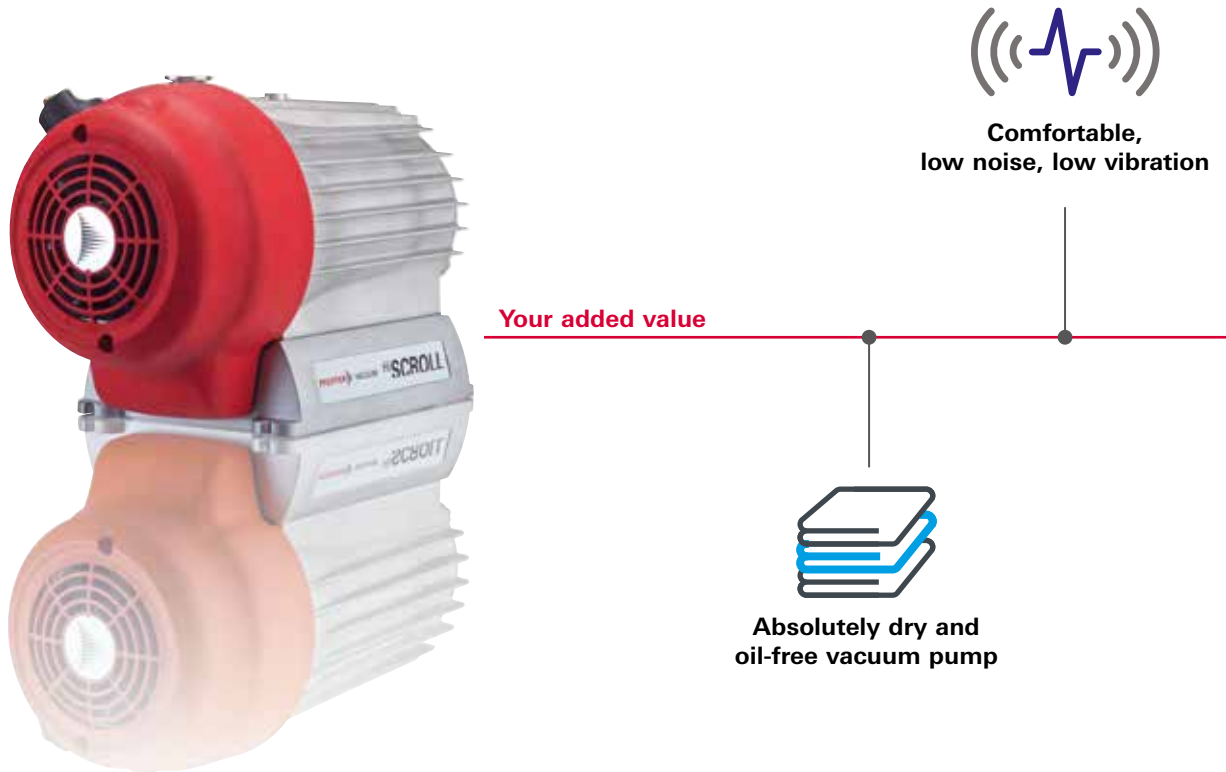

HiScroll - the oil-free vacuum pumps

The HiScroll series consists of three dry and hermetically sealed scroll pumps with a nominal pumping speed of 6 - 20 m³/h. The pumps are characterized in particular by their high efficiency and low noise level. The pumps are characterized in particular by their high performance when evacuating against atmosphere. Their powerful IPM¹⁾ synchronous motors with sensorless INFORM[®] control²⁾ achieve up to 15% higher efficiency compared to conventional drives. This enables maximum performance at low temperatures, resulting in more efficient cooling of compact systems and equipment.

Intelligent control

The HiScroll's adaptive fan control ensures optimum cooling under different operating conditions and also reduces noise emissions when the full power of the pump system is not required. A unique integrated pressure sensor (optional) enables fully automatic pressure regulation together with intelligent speed control. This helps to minimise energy consumption, wear and noise emission, thus ensuring longer maintenance cycles.

HiScroll pumps can be easily connected via RS-485 or ProfiNet to other Pfeiffer Vacuum products, such as turbopumps or display and control units, as well as to a higher-level external control system.

¹⁾ Interior Permanent Magnet

²⁾ INFORM[®] method according to Prof. Schrödl



Lowest operating costs through fully automatic pressure regulation



Safe operation due to built-in non-return valve and hermetically sealed pump system



Optimal process adaptation through intelligent interface technology



Compact design for use in analysis systems/ laboratory equipment



Explosion-proof ATEX design

Lowest noise emission on the market

The HiScroll pumps are extremely quiet with <47 dB[A] (in stand-by mode <42 dB[A]). Their very compact design and low-vibration operation also distinguish the pumps. This makes them ideal for use in quiet working environments, for example on mass spectrometers, in research institutes or leak detection systems.

High safety at low cost:

High water vapor compatibility is ensured by the two-stage gas ballast valve. It also allows a more individual adjustment to your process. The built-in non-return valve and the self-regulating operation of the pump assure safe operation.

The proven quality of Pfeiffer Vacuum components assures a long service life. Pump maintenance is simple and allows for short service times, while the efficient motor helps reduce electricity costs.

ATEX certification:

HiScroll pumps are already certified to ATEX II 3/G Ex h IIC T4 Gc X +5° C ≤ Ta ≤ +40 °C as standard. This means that HiScroll pumps can be used with internal explosion protection of equipment category 3G for Ex zone 2 with gas types IIC. These versions are only available without the optional integrated pressure sensor, as only ATEX certified accessories may also be used in ATEX applications.

HiScroll®

The extremely quiet, efficient, oil-free pumps that reduce your CO₂ footprint.

Power as required

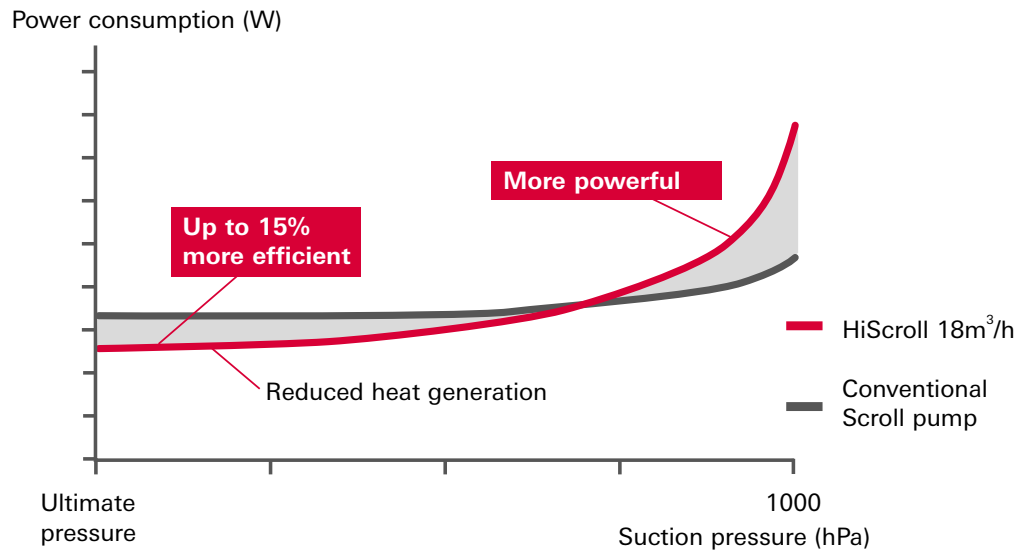

Constant pumping speed

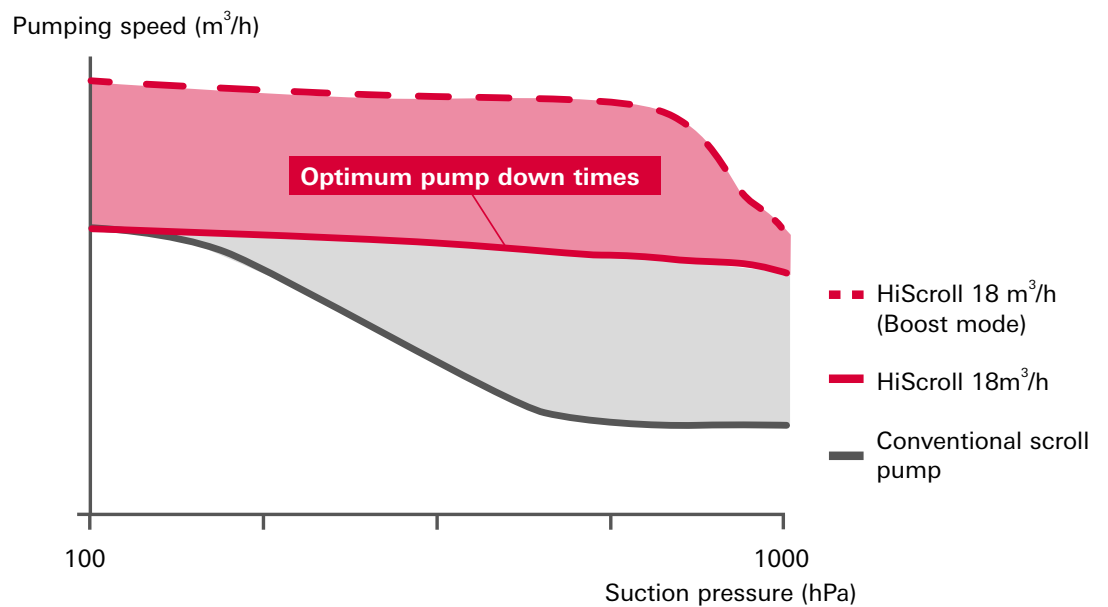

We drive sustainable solutions

Environmentally friendly

By using innovative IPM¹⁾ synchronous motors with sensorless INFORM[®] control²⁾, our HiScroll pumps achieve environmentally friendly efficiency. The reduction in power requirements combined with high pumping capacity results in lower operating costs for the operator: the motor achieves premium efficiency and significantly exceeds the minimum values of efficiency level IE3 as applicable to standard asynchronous motors. Everyone benefits from this.

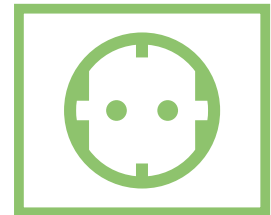

In addition, the use of the new IPM motor technology results in significantly smaller product dimensions compared to products using asynchronous motors.

Conserving resources

However, environmental benefits are not limited to the pump's performance and installation dimensions. Our HiScroll already scores points in production through conscious material savings. For example, less copper is used and advanced technologies make it possible to dispense with additional sensors. The pump housing, as well as the cover and the housing of the electronics, are manufactured by casting, which avoids excessive production waste.

Even the packaging is designed to conserve resources: Weight-optimized and space-saving insulating materials effectively protect our HiScroll from transport damage and at the same time ensure an optimized transport weight.

Sustainable

Last but not least, man and machine benefit equally from the sustainable use of state-of-the-art technologies: The new generation scroll pumps emit less waste heat and also have a longer service life thanks to their innovative standby operation. They run extremely quietly and with low vibration, making their working environment safe and comfortable.

¹⁾ Interior Permanent Magnet

²⁾ INFORM[®] method according to Prof. Schnödl



HiScroll®

Details and application examples

Exploded view

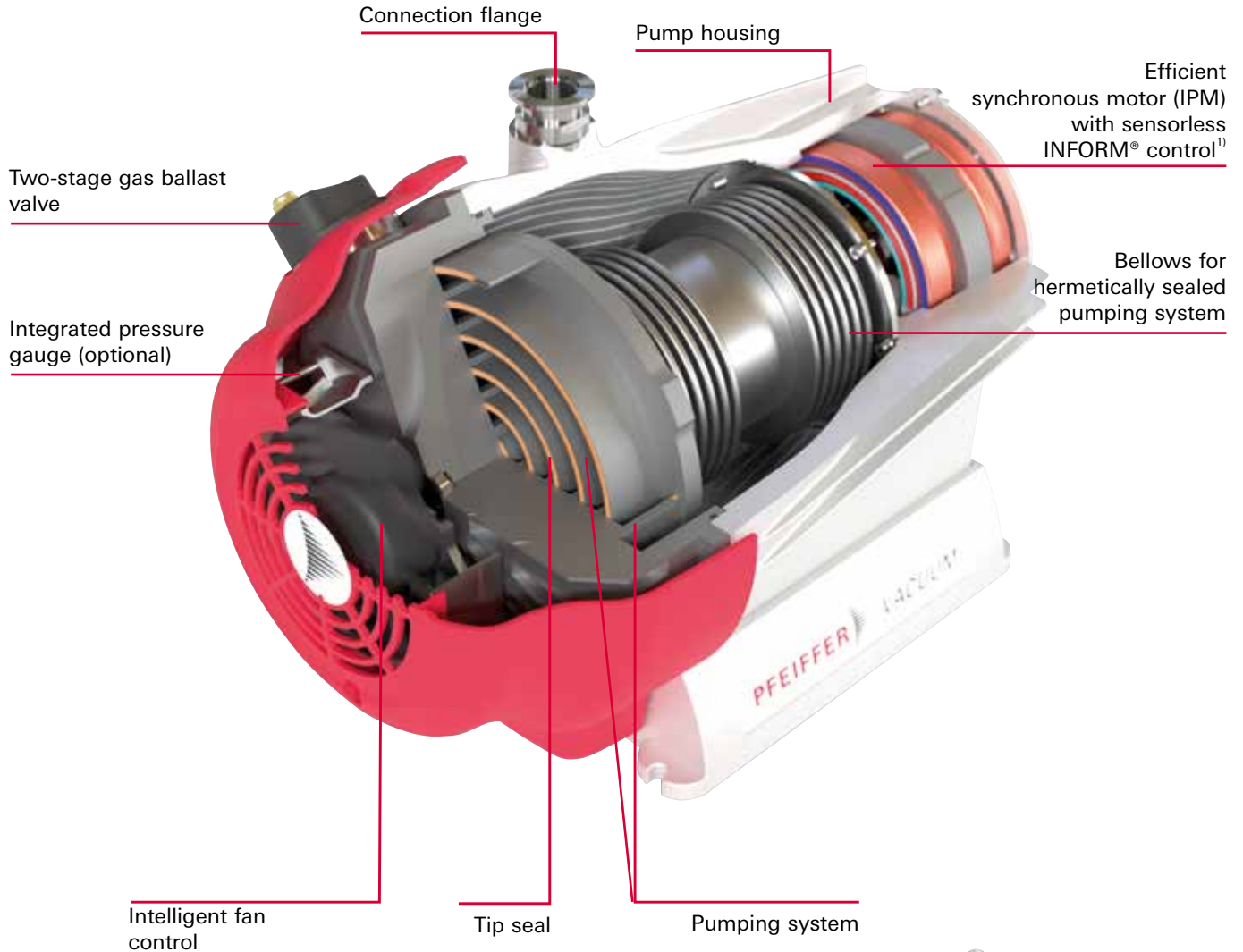

Typical applications

- Mass spectrometry
- Accelerator
- Laboratories
- Leak detection
- Semiconductor technology
- Coating
- Gas recovery
- Vacuum drying



¹⁾ INFORM® method according to Prof. Schnödl



HiScroll®

Pumping speed, dimensional drawings

Pumping speed

HiScroll 6

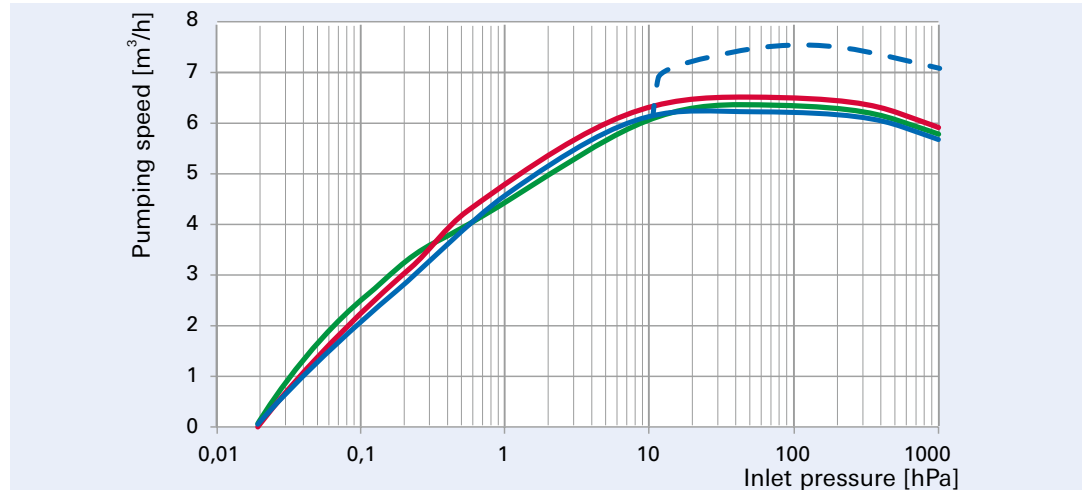

HiScroll 12

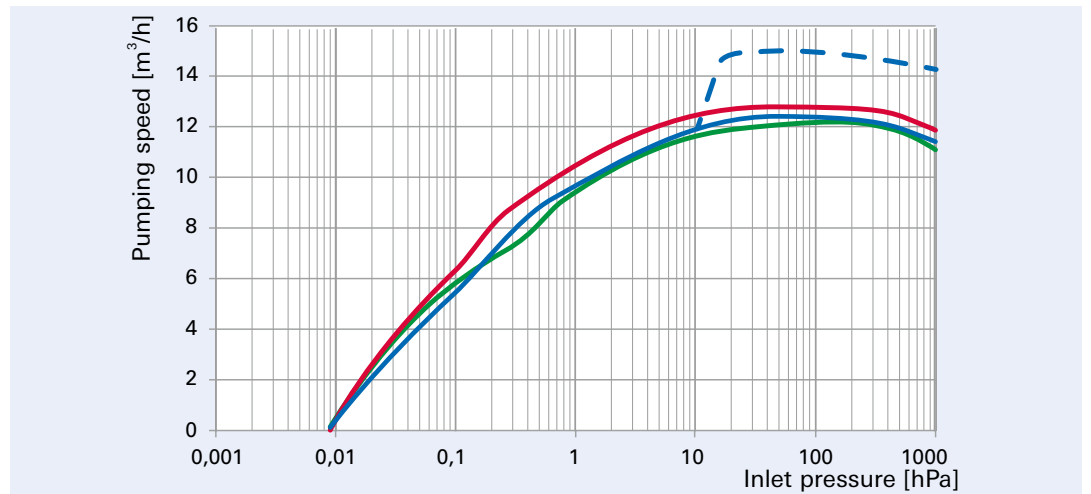

HiScroll 18

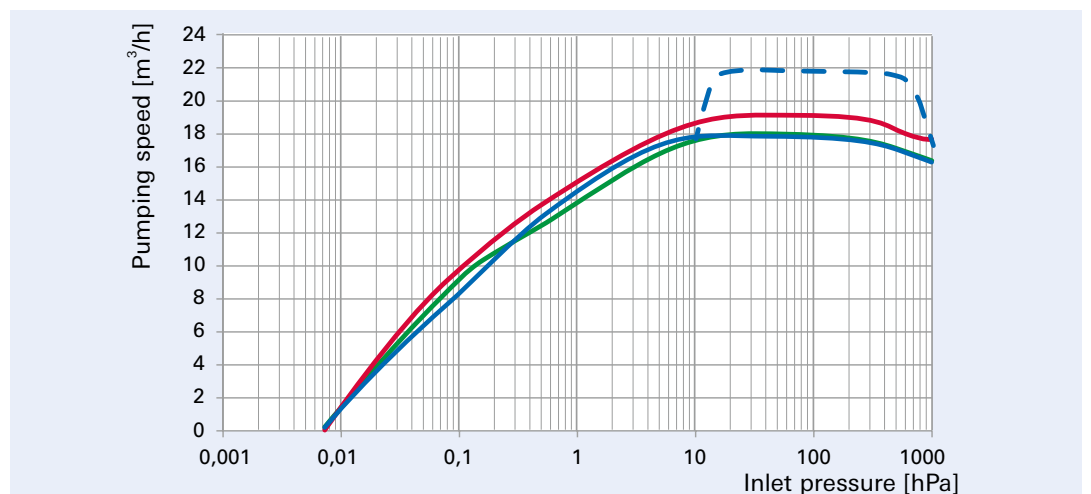

Boost mode - - - - -
N₂ - - - - -
Ar - - - - -
He - - - - -

Dimensional drawings

HiScroll 6

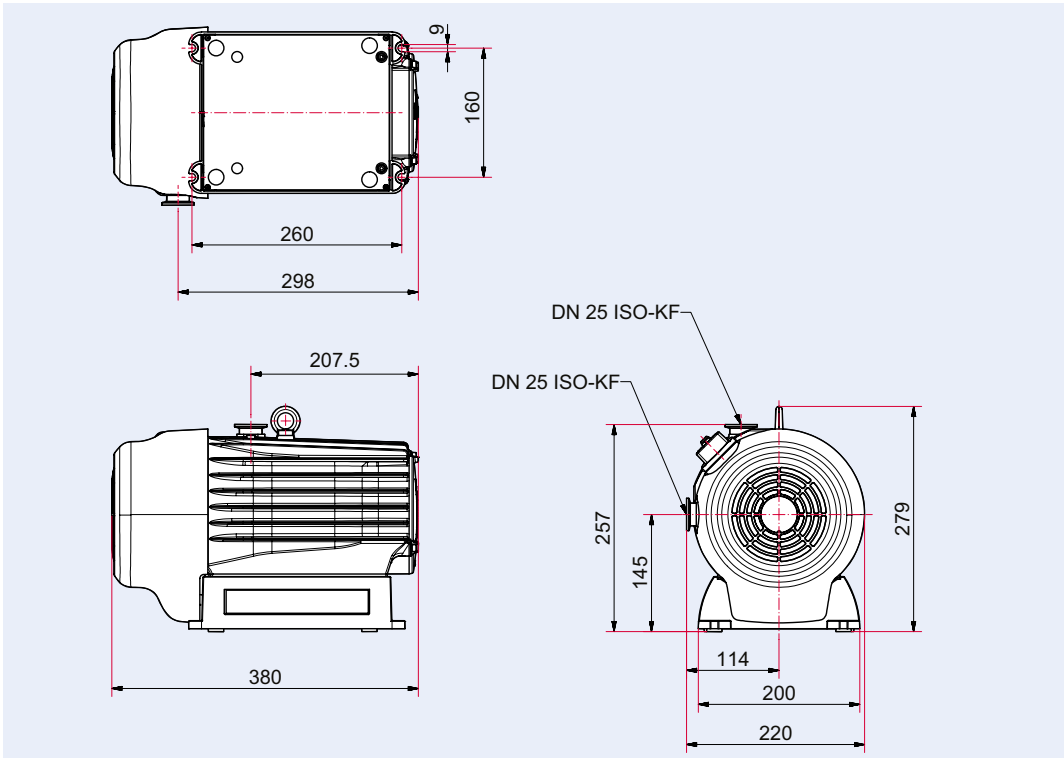

HiScroll 12 / HiScroll 18

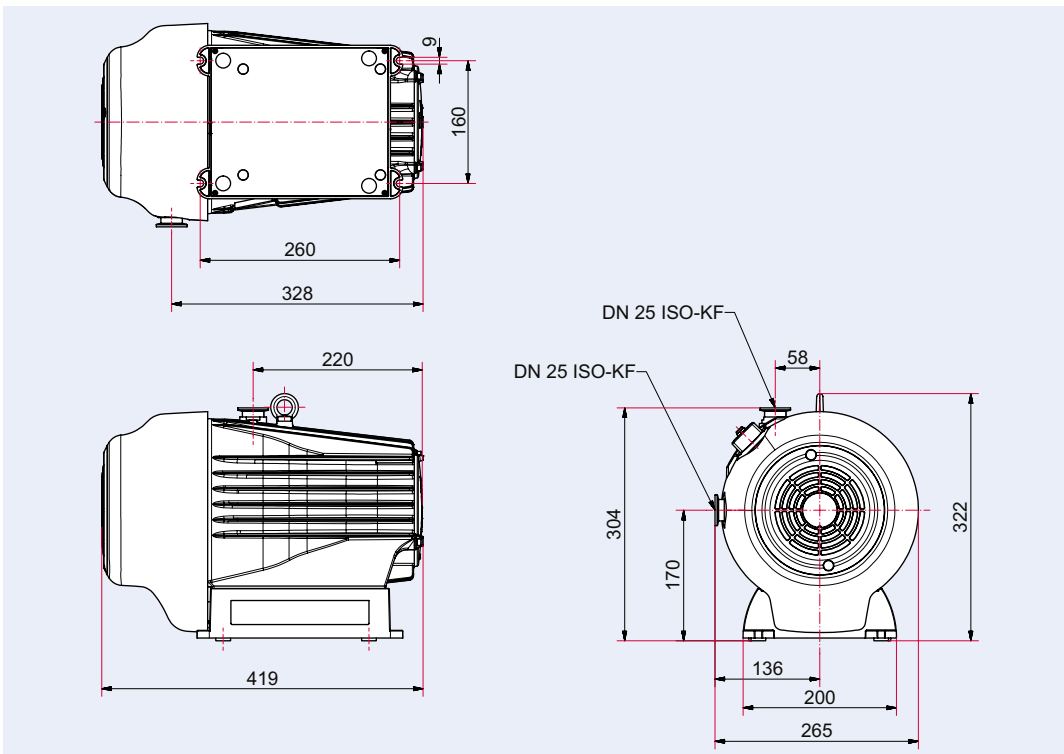

Dimensions in mm

HiScroll®

Technical data, order number matrix,
accessories

Technische Daten

	HiScroll 6	HiScroll 12	HiScroll 18
Pumping speed	6.1 m ³ /h	12.1 m ³ /h	18.1 m ³ /h
Ultimate pressure	2 · 10 ⁻² hPa	9 · 10 ⁻³ hPa	7 · 10 ⁻³ hPa
Tested basic pressure ²⁾	5 · 10 ⁻² hPa	3 · 10 ⁻² hPa	2 · 10 ⁻² hPa
Ultimate pressure with gas ballast stage ¹⁾	7 · 10 ⁻² hPa	5 · 10 ⁻² hPa	3 · 10 ⁻² hPa
Ultimate pressure with gas ballast stage ²⁾	4 · 10 ⁻¹ hPa	4 · 10 ⁻¹ hPa	2 · 10 ⁻¹ hPa
Gas ballast flow stage 1	11 l/min	18 l/min	23 l/min
Gas ballast flow stage 2	16 l/min	30 l/min	30 l/min
Leakage rate	5 · 10 ⁻⁷ Pa m ³ /s		
Intake pressure, max.	1100 hPa		
Exhaust pressure, max.	1500 hPa		
Connection flange (inlet)	DN 25 ISO-KF		
Connection flange (output)	DN 25 ISO-KF		
I/O interfaces	RS-485		
Mains connection	100–127/200–240 V AC (±10 %), 50/60 Hz		
Current max.	10,0 A		
Speed	1,000–3,000 rpm	624–1,870 rpm	624–1,870 rpm
Rated speed	2,500 rpm	1,560 rpm	1,560 rpm
Protection class	IP20		
Certifications	cTUVus tested according to UL / CSA 61010-1		
Switch	Yes		
Ambient temperature	5–40 °C		
Temperature: Storage	-10–50 °C		
Temperature: Shipping	-25–55 °C		
Cooling type	Air, Forced convection		
Emission sound pressure level (EN ISO 2151)	48 dB(A)	47 dB(A)	47 dB(A)
Weight	19 kg	24 kg	23 kg
Gas ballast	Yes		
Operating height, max.	2500 m		

HiScroll

<47 dB(A)

Sound emission

5 · 10⁻⁷ Pa m³/s

Leakage rate



¹⁾ The final pressure is usually reached after a certain running time.

The run-in process can be accelerated by using gas ballast and/or nitrogen.

²⁾ Tested base pressure during quality control before shipment according to ISO 21360.
Quality control is performed with a calibrated gas type independent pressure gauge.

Order number matrix HiScroll

Size	a
HiScroll 6	1
HiScroll 12	2
HiScroll 18	3

Equipment	b
Standard, ATEX certified	0
Integrated pressure sensor RPT010	1

Gas ballast	c
2-stage manual gas ballast	0
Gas ballast permanently closed	1

PD Sa0 0bc

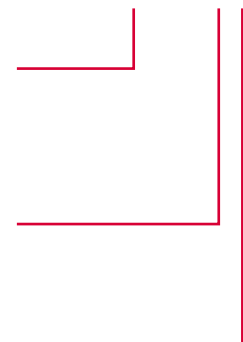

Zubehör

	Order number
Accessory cable	
Mains cable 230 V AC, CEE 7/7 to C13, 3 m	P 4564 309 ZA
Mains cable 115 V AC, NEMA 5-15 to C13, 3 m	P 4564 309 ZL
Interface cable M12 m straight/M12 m, straight,	PM 061 283 -T
USB RS-485 converter	PM 061 207 -T
Adapter, RS-485 M12	PE 100 150 -X
Y-distributor M12 for RS-485	P 4723 010
Connecting cable HiScroll / HiPace / TC 400, 3 m	PM 071 732 -T
Connecting cable HiScroll / HiPace / TC 110 / TPS, 3 m	PM 071 733 -T
Remote controller	
DCU 002, Display Control Unit	PM 061 348 AT
HPU 001, Handheld Programming Unit	PM 051 510 -T
Filter	
SAS 25 S, dust collector with polyester filter insert	PK Z60 507
Silencer	
ES 25 M, External silencer HiScroll	PD Z10 000
ES 25 L, External silencer HiScroll	PD Z10 001
Components	
Push-in fitting G 1/8" including seal for hose connection (8/6 mm)	P 4131 029
Closing cap for gas ballast valve	PD 100 067
Spare parts packages	
Maintenance kit Level 1, TipSeal Kit, HiScroll 6	PD E10 000 -T
Maintenance kit Level 1, TipSeal Kit, HiScroll 12/18	PD E20 000 -T
O-ring lifter	PV A00 778

Further accessories can be found on our website at www.pfeiffer-vacuum.com.

Tip:

Spare parts packages
 With the original Pfeiffer Vacuum spare parts packages and the appropriate tools, you can change the tip seal of your HiScroll yourself in about 15 minutes.





Are you looking for an optimal vacuum solution?
Please contact us:

Pfeiffer Vacuum GmbH
Germany
Phone +49 6441 802-0

Follow us on social media
#pfeiffervacuum



www.pfeiffer-vacuum.com



Errors excepted. All data subject to change without prior notice. PU 0066 PEN (September 2021/PoD)