

## POWER HiTESTER 3193-10

Power Measuring Instruments

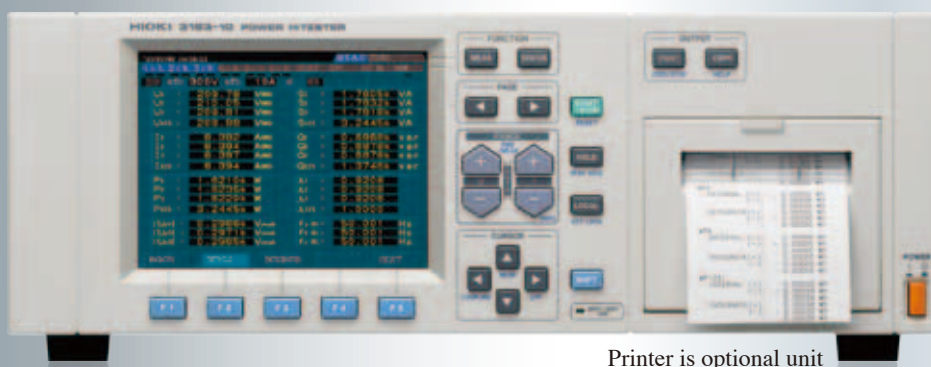

# Wide Spectrum Power Meter for Comprehensive Device Assessment



Printer is optional unit

## DC/0.5Hz to 1MHz broad-band POWER HiTESTER measures up to 6 systems simultaneously.

The POWER HiTESTER 3193-10 is a multi-function power meter for use with single phase power lines to 3-phase, 4-wire circuits. Accommodating up to 6 units, it is not only capable of measuring up to 6 single phase systems, but can simultaneously measure the input and output of a 3-phase inverter and provide effective power measurements. Additionally, it supports harmonic analysis and flicker measurement (optional), features which are essential for overall device assessment. Standard features include a GP-IB and RS-232C interface, making it easy to feed data to a personal computer for processing and analysis. This unit is ideal for those requiring greater efficiency in electrical device assessment.

### AC/DC CURRENT SENSOR



- Rated at 1000A rms
- Wide bandwidth
- Super high precision

Broad coverage, high accuracy, and well-developed interface

# Complete with functions that answer all your power measurement needs.

HIOKI 3193-10 POWER HITESTER

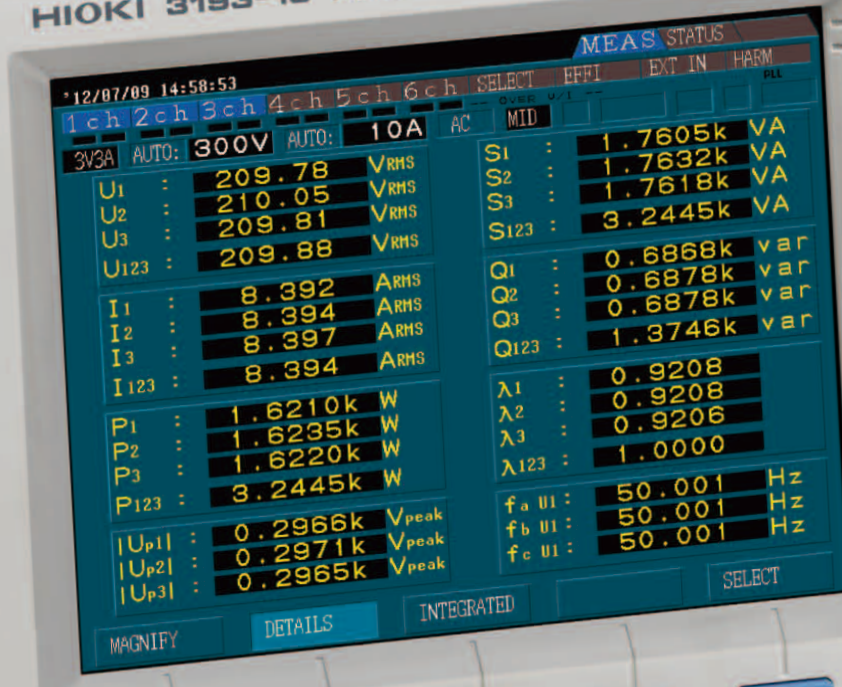

## Features

### ■ Wide range of measurement functions

Capable of measuring voltage, current, active /reactive /apparent power, power factor, phase, frequency, and current, and of integrating power according to polarity, the 3193-10 also provides wave peak and efficiency measurements that are essential to device assessment.

### ■ Measure Motor Output

With the optional EXTERNAL SIGNAL INPUT UNIT 9603, the HiTESTER can take analog input in from torque and revolution measurements and use that information to calculate motor output.

### ■ Measurement for Minute Stand-by Power also Available (by special-order)

The 9600 and 9601 input units have 10-times improved current sensitivity, and currents starting from the 20.000mA range can be measured. (Please inquire for further information.)

### ■ High Visibility Color LCD

Featuring a wide viewing angle, the color LCD displays a variety of items simultaneously, making it ideal for quickly grasping power usage on the system being measured. Expanded display is possible for any four selected items.

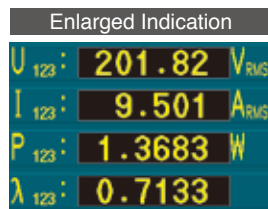

### ■ Harmonic and Flicker Analysis

Harmonic and flicker analysis are possible when using the optional HARMONIC / FLICKER MEASUREMENTS UNIT 9605.

### ■ High Basic Accuracy of $\pm 0.2\%$

Measurements of even greater precision can be obtained using the optional 9600 to 9602 input unit, which provides a basic accuracy of  $\pm 0.1\%$  rdg,  $\pm 0.1\%$  f.s. (With the 9602, the accuracy of the clamp-on sensor is a factor affecting total accuracy during power measurement.)

### ■ A Variety of Interfaces for Differing Needs

#### ★ Connecting to a PC

The RS-232C and GP-IB interface, provided as standard features, make it possible to connect the power meter directly to a PC, allowing efficient measurement, management and analysis of data.



#### ★ Connecting to a Recorder

With 8 selectable D/A outputs and voltage, current and power analog/monitor output (current and voltage only) as standard features, the HiTESTER allows recording of changes and transient fluctuations in waveforms using a recording unit.



#### ★ Connecting to a Printer

Data can be output to the optional PRINTER UNIT 9604.



Print type : Thermal line dot printing  
Paper width : 72mm  
Main functions : printing of items measured, hard copy output of displayed screens, printout of meter settings, printout of various times (such as interval time, timer time, and realtime control time). Printouts are performed either automatically, upon input of an external control signal, or synchronized with an integrator.

# DC/0.5Hz to 1MHz broad-band POWER HiTESTER measures up to 6 systems simultaneously.



## Choose from a variety of input units according to application

Three types of input units are available, including the 9602 AC/DC Clamp Input Unit, which can be used with current levels exceeding 50A under live circuit conditions, as well as the 9600 and 9601 which accept direct input of up to 1000V/50A.

- 9600 . . . DC/0.5Hz to 1MHz wide band
- 9601 . . . 5Hz to 100kHz, for AC only
- 9602 . . . DC/0.5Hz to 200kHz **clamp input**

Choose from a variety of sensors including AC Clamp On Sensors 9272-10 and 9290-10, AC/DC CURRENT PROBES CT6841, CT6843 and 9279, and super high-precision AC/DC Sensors CT6865, 9709, CT6862 and CT6863.

1ch	2ch	3ch	4ch	5ch	6ch
1 $\phi$ 2W	1 $\phi$ 2W	1 $\phi$ 2W	1 $\phi$ 2W	1 $\phi$ 2W	1 $\phi$ 2W
1 $\phi$ 3W / 3 $\phi$ 3W	1 $\phi$ 2W	1 $\phi$ 2W	1 $\phi$ 2W	1 $\phi$ 2W	1 $\phi$ 2W
1 $\phi$ 3W / 3 $\phi$ 3W	1 $\phi$ 3W / 3 $\phi$ 3W	1 $\phi$ 3W / 3 $\phi$ 3W	1 $\phi$ 2W	1 $\phi$ 2W	1 $\phi$ 2W
1 $\phi$ 3W / 3 $\phi$ 3W	1 $\phi$ 3W / 3 $\phi$ 3W	1 $\phi$ 3W / 3 $\phi$ 3W	1 $\phi$ 2W	1 $\phi$ 2W	1 $\phi$ 2W
3V3A (3 $\phi$ 3W) / 3 $\phi$ 4W	3V3A (3 $\phi$ 3W) / 3 $\phi$ 4W	3V3A (3 $\phi$ 3W) / 3 $\phi$ 4W	1 $\phi$ 2W	1 $\phi$ 2W	1 $\phi$ 2W
3V3A (3 $\phi$ 3W) / 3 $\phi$ 4W	3V3A (3 $\phi$ 3W) / 3 $\phi$ 4W	3V3A (3 $\phi$ 3W) / 3 $\phi$ 4W	1 $\phi$ 3W / 3 $\phi$ 3W	1 $\phi$ 2W	1 $\phi$ 2W
3V3A (3 $\phi$ 3W) / 3 $\phi$ 4W	3V3A (3 $\phi$ 3W) / 3 $\phi$ 4W	3V3A (3 $\phi$ 3W) / 3 $\phi$ 4W	3V3A (3 $\phi$ 3W) / 3 $\phi$ 4W	3V3A (3 $\phi$ 3W) / 3 $\phi$ 4W	3V3A (3 $\phi$ 3W) / 3 $\phi$ 4W

### Feed-through current sensors



### Clamp-on sensors



## Simultaneous Measurement of Multiple Systems

Since all units are mutually isolated, the primary and secondary sides of devices or disparate power lines can be measured simultaneously. Simultaneous measurement of single phase 6 wire or 3 phase 2 wire systems which previously required multiple units, can now be handled with one. What's more, measurements of all devices can be taken at the same instant, providing a powerful tool for integrated, all-round device assessment.

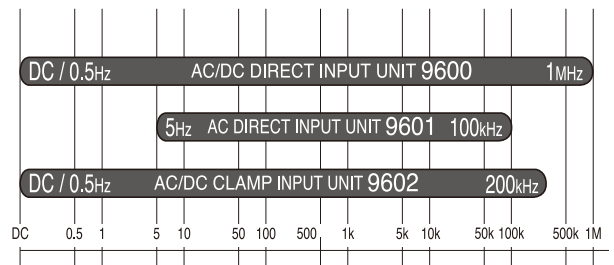

9600 Frequency characteristics (at 15W[15Vx1A] range, response slow)

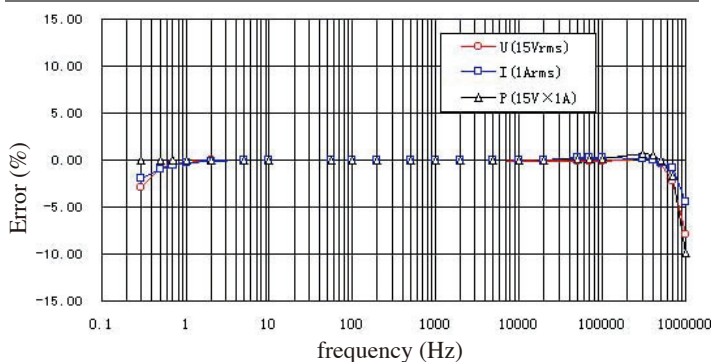

Effect of common mode voltage

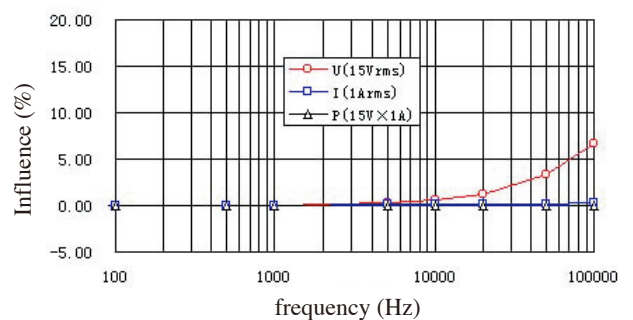



Measure all items at same point in time

# The Power Analysis Station

## Applications of 3193-10

### Example of Application With Power Converter

Measure mixed AC and DC components with a single unit.

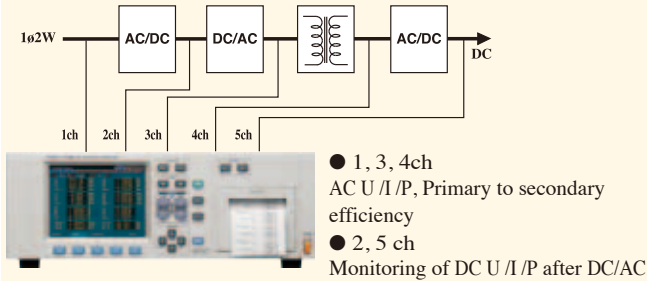

### Example of Assessment Trial of EV ( Electric Vehicle)

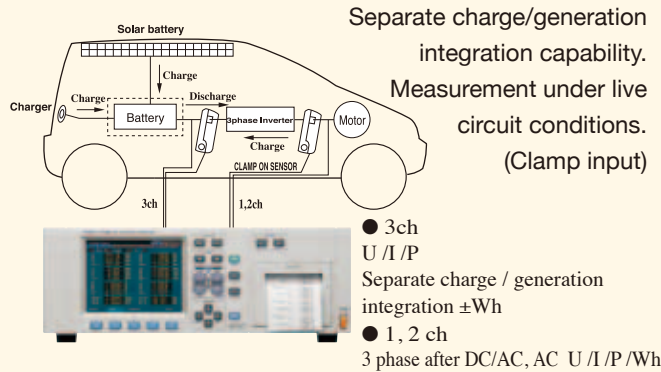

## Even Supports Harmonic / Flicker analysis when using the optional 9605 HARMONIC / FLICKER MEASUREMENTS UNIT .

### Graph Display of Harmonics

Voltage, current and power can be analyzed and displayed by bargraphs of harmonic amplitude, content and phase angle. Voltage, current and power can be displayed simultaneously for a single channel, or a single parameter can be displayed simultaneously for each of three channels.



### Waveform Display

The waveform display shows one cycle of the voltage and current waveforms. RMS and peak values can be displayed along with voltage and current waveforms, or voltage and current waveforms for up to three channels can be displayed at the same time.

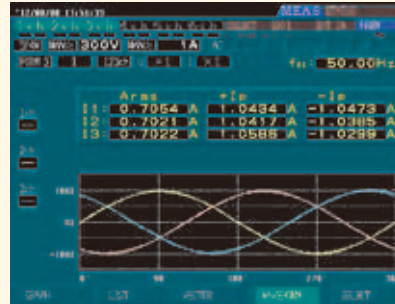

### List Display of Harmonics

The harmonic list display shows the amplitude, proportion, phase angle and distortion for each harmonic of voltage, current and power. Displaying only proportion, or two parameters simultaneously, such as amplitude and phase angle, is selectable.



### Vector Display of Harmonics

The harmonic vector display shows the voltage, current and phase angle for each harmonic, making clear the voltage-current phase relationship.



### Flicker Measurement Display

Displays data during measurement in real-time. Display can also be switched to D measurement and "Pst" value.



### Monitor Display

The relative "d" voltage change ΔV/V and the instantaneous flicker value "S(t)" can be displayed in a time series, so past variations are clearly displayed.

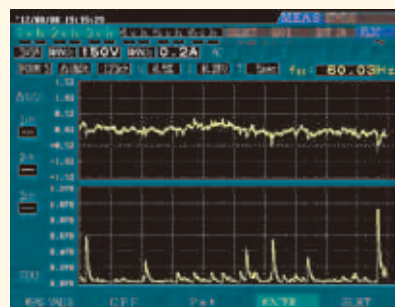

9605 Specifications (optional)	
<b>Installation</b>	: Installs in the 3193-10 main unit
<b>Measurement lines</b>	: Single-phase 2- and 3-wire, three-phase 4-wire
<b>No. of channels</b>	: Up to 3 channels within channels 1 to 6, depending on 3193-10 wiring mode
<b>Output functions</b>	: RS-232C, GP-IB, printer
<b>● Harmonic Waveform Analysis Functions</b>	
<b>Measurement range</b>	: Fundamental frequency: 1 to 440 Hz PLL system (5 to 440 Hz), external clock system (1 to 5 Hz)
<b>Orders analyzed</b>	: Up to 50th harmonic (with 1 to 250 Hz fundamental)
<b>Window width</b>	: 16 cycles (for 40 to 70 Hz fundamental)
<b>Windowing type</b>	: Rectangular tiling (no gap between or overlap of windows)
<b>Amount of data analyzed</b>	: 512 points (for 40 to 70 Hz fundamental)
<b>Crest factor</b>	: Up to 4 (current), and up to 3 (voltage)
<b>Measurement items</b>	: Harmonic level, percentage and phase angle of each order of harmonic wave for each of voltage, current and power. Total up to 50th harmonic (of 40 to 70 Hz fundamental) for voltage, current and power. Total harmonic distortion for voltage and current (THD-F and THD-R) Measurement of voltage, current, active power, peak voltage and peak current values of the fundamental
<b>Update rate</b>	: Every 1 window (except during communications with other devices)
<b>Screen displays</b>	: List, graph, vector and waveform
<b>Accuracy*</b>	: Harmonic levels; at 45 to 66 Hz Voltage/current: $\pm 0.5\% \text{rdg} \pm 0.05\% \text{f.s.}$ Active power: $\pm 1.0\% \text{rdg} \pm 0.1\% \text{f.s.}$ For 45 to 66-Hz fundamental, effective input is 0.1 to 110% of range
<b>● Flicker Measurement Function</b>	
<b>Measurement range</b>	: Fundamental frequency; 45 to 66 Hz, PLL synchronization system
<b>Analysis items</b>	: dc (relative constant voltage change), d max (max. relative constant voltage change), d(t)500ms (relative voltage change per time), P0.1/P1s/ P3s/ P10s and 30s (cumulative probability), Pst (short-term flicker value), Plt (long-term flicker value)
<b>Screen displays</b>	: Measured value, CPF, Pst list, Monitor
<b>Accuracy*</b>	: RMS voltage $\pm 0.5\% \text{rdg} \pm 0.05\% \text{f.s.}$ (45Hz~66Hz)
* The reading accuracy of the input unit must combined with the analysis accuracy shown above. When used with a clamp sensor, accuracy and frequency characteristics of the clamp must be added to the analysis accuracy above.	

## Other Analysis Functions

**Integration According to Polarity**

Positive, negative, and total current and power can be integrated simultaneously for all channels. This makes it possible to grasp the income and outflow of power at a glance.

Ih1	:	182.4192 Ah
Ih2	:	183.4560 Ah
Ih3	:	181.4405 Ah
+WP123 : 26.27136kWh		
-WP123 : -0.28454kWh		
WP123 : 25.98682kWh		

**Peak Measurements Function**

Voltage and current wave peaks can be measured. The Peak Hold function can be used to find peak values and effective maximums for motor rush current waves.

U <sub>p1</sub>	:	285.44	V <sub>peak</sub>
U <sub>p2</sub>	:	285.47	V <sub>peak</sub>
U <sub>p3</sub>	:	285.11	V <sub>peak</sub>

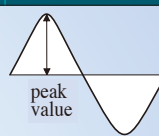

**Analog and D/A Output**

Analog (voltage, current, and effective power) and D/A outputs (any selected eight items) are output as a 5V range full scale value. (Except for the 1000V range), 100ms response time can be obtained by using the FAST setting.

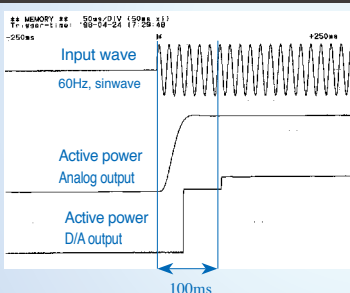

**Wave Monitor Output**

With the voltage and current ranges, waveforms are output as 1V full scale values, allowing waveforms to be monitored using devices such as recorders or synchroscopes.

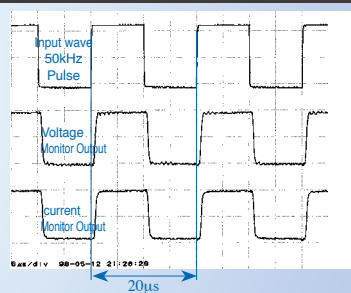

- **3 Types of Averaging Functions**  
Select from time average, moving average and exponential average.
- **3ch Frequency Measurement Function**  
With the frequency ranges, LPF and HPF can be used in combination, allowing measurement of fundamental waveforms and carrier waveforms of inverters.
- **Efficiency Calculation Function**  
Three efficiency calculations can be obtained simultaneously from measured voltage values.

- **3 Types of Built-in Low Pass Filters**  
Selectable cutoff frequencies (500/5k/300kHz) allow extraction of the frequency component of fundamental inverter waveforms and provide data compatibility with previous instruments.
- **Choose from Three Types of Calculation Algorithms**  
Three selectable algorithms are provided for calculating apparent power and reactive power, providing compatibility with previous devices

### Multi-Channel Recorders

MEMORY HiCORDER MR8847-01/02/03



The Ideal Recorder for Field Use, Easy Portability and Sturdy Construction

- 20M-Sampling/s
- Max. 16 ch + logic 16 ch
- 32M to 256M-Word Memory (2ch)

MEMORY HiCORDER MR8875



Smart Design - Smart Engineering

- 500k-Sampling/s
- Max. 16ch+Logic 8ch
- Memory 8M-word by each input unit, total 32M-words

## Optional Input Unit Specifications

Customized versions of Models 9600 and 9601 are also available for stand-by power measurement with 10-times improved sensitivity for current ranges. Please ask for detailed specs.

	AC/DC DIRECT INPUT UNIT 9600			AC/DC CLAMP INPUT UNIT 9602		
	Voltage	Current	Active power	Voltage	Current	Active power
Measurement range	6.0000/15.000/30.000/ 60.000/150.00/300.00/ 600.00V/1.0000 kV	200.00/500.00mA/ 1.0000/2.0000/5.0000/ 10.000/20.000/50.000 A	Depends on combination of voltage and current ranges	6.0000/15.000/30.000/ 60.000/150.00/300.00/ 600.00V	500.00mA to 1000.0A (Depends on clamp-on sensor)	Depends on combination of voltage and current ranges
Max. operating input <sub>(55Hz)</sub>	1000Vrms/1500 V peak	65Arms/100 A peak		650Vrms/850Vpeak	(Depends on clamp-on sensor)	
Crest factor	Lower of either (measured range X 6) / measured value or maximum permissible rated peak / measured value			Lower of either (measured range X 6) / measured value or maximum permissible rated peak/measured value		
Input resistance	2MΩ±5%	1mΩ max.		2MΩ±5%	200kΩ±5%	
Accuracy	(Accuracy assured at 23°C±5°C (73°F ±9°F) at 80% R.H., power factor = 1, sine wave input, in-phase voltage 0, after DMAG)					
DC	±0.1%rdg.±0.2%f.s.	←	←	±0.1%rdg.±0.2%f.s.	←	←
0.5 to 1Hz	±0.5%rdg.±0.5%f.s.	←	←	±0.5%rdg.±0.5%f.s.	←	←
1 to 10Hz	±0.2%rdg.±0.2%f.s.	←	←	±0.2%rdg.±0.2%f.s.	←	←
10 to 45Hz	±0.1%rdg.±0.2%f.s.	←	←	±0.1%rdg.±0.2%f.s.	←	←
45 to 66Hz	±0.1%rdg.±0.1%f.s.	←	←	±0.1%rdg.±0.1%f.s.	←	←
66Hz to 10kHz	±0.1%rdg.±0.2%f.s.	←	←	±0.1%rdg.±0.2%f.s.	←	←
10 k to 50kHz	±0.3%rdg.±0.3%f.s.	←	←	±0.5%rdg.±0.5%f.s.	←	←
		Less than 5 A Greater than 5 A	Less than 5 A Greater than 5 A			
50 k to 100kHz	±0.5%rdg.±0.5%f.s.	±0.5%rdg. ±0.5%f.s.	±2.5%f.s.	±0.5%rdg. ±0.5%f.s.	±5.0%f.s.	±0.3%rdg.±0.5%f.s.
100k to 300kHz	±0.5%rdg.±0.5%f.s.	±0.5%rdg. ±0.5%f.s.	±5%f.s.	±1.0%rdg. ±1.5%f.s.	±10.0%f.s.	±15%f.s. (up to 200kHz)
300k to 400kHz	±1.5%rdg.±0.5%f.s.	±1.0%rdg. ±0.5%f.s.		±1.0%rdg. ±2.5%f.s.		
400k to 500kHz	±2.0%rdg.±1.0%f.s.	±2.0%rdg. ±1.0%f.s.		±2.0%rdg. ±2.5%f.s.		
500k to 700kHz	±10.0%f.s.	±10.0%f.s.		±15.0%f.s.		
700k to 1 MHz	±15.0%f.s.	±15.0%f.s.		±30.0%f.s.		

Compatible Clamp (Optional) 9279-01 9272-10 CT6862 CT6863 CT6841/CT6843 CT6865/9709

With the 9602, the accuracy of the clamp-on sensor is a factor affecting total accuracy during current measurement, as are phase and frequency characteristics. See page 8 for details on the clamp-on sensor specifications.

	AC DIRECT INPUT UNIT 9601		
	Voltage	Current	Active power
Measurement range	60.0000/150.00/300.00/6 00.00V/1.0000 kV	200.00/500.00mA/ 1.0000/2.0000/5.0000/ 10.000/20.000/50.000 A	Depends on combination of voltage and current ranges
Max. operating input <sub>(55Hz)</sub>	1000Vrms/1500 V peak	65Arms/100 A peak	
Crest factor	Lower of either (measured range X 6) / measured value or maximum permissible rated peak / measured value		
Input resistance	2MΩ±5%	1mΩ max.	
Accuracy	(Accuracy assured at 23°C±5°C (73°F ±9°F) at 80% R.H., power factor = 1, sine wave input, in-phase voltage 0)		
5 to 10Hz	±2.5%f.s.	←	←
10 to 20Hz	±1.0%f.s.	←	←
20 to 45Hz	±0.1%rdg.±0.2%f.s.	←	←
45 to 66Hz	±0.1%rdg.±0.1%f.s.	←	←
66Hz to 5kHz	±0.1%rdg.±0.2%f.s.	←	←
5k to 10kHz	±0.2%rdg.±0.4%f.s.	←	←
10k to 20kHz	±1.0%f.s.	←	←
20k to 50kHz	±2.5%f.s.	←	←
50k to 100kHz	±10.0%f.s.	←	←

### Assured Accuracy Range for Input Frequency of the 9600

9601 and 9602 each have assured ranges for input frequency.

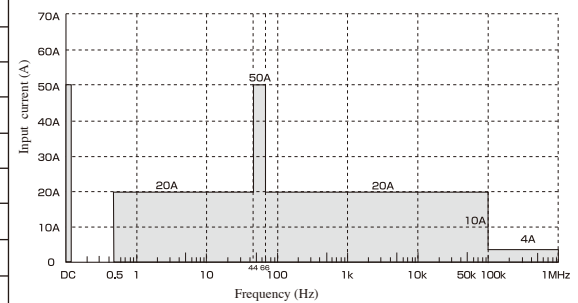
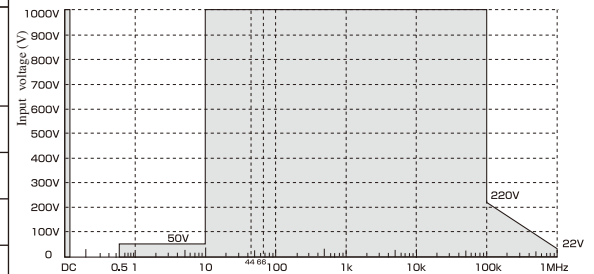

Note 1: Assured accuracy ranges for different response settings are as follows: FAST (0.1 sec) to DC and greater than 50 Hz, MID (0.8 sec) to DC and greater than 10 Hz, SLOW (5.0 sec) to DC or greater than 0.5 Hz

Note 2: Assured accuracy ranges for combined mode measurement are 10 Hz or greater for the AC mode, and DC only for the AC+DC mode or DC mode.

### Calculation algorithm

(Indicated only for single phase, 2 wire and 3 phase, 3 wire (3V3A). Two additional calculation algorithms can be selected for apparent/reactive power)

	Voltage	Current	Active power	Apparent power	Reactive power	Power factor	Phase
1φ2W	$U_1$	$I_1$	$P_1$	$S_1=U_1 \times I_1$	$Q_1=s_1 \sqrt{(U_1 I_1)^2 - P_1^2}$	$\lambda_1=s_1 P_1 / S_1$	$\phi_1=s_1 \cos^{-1}  \lambda_1 $
SUM 3φ3W (3V3A)	$U_{1,2,3} = \frac{U_1+U_2+U_3}{3}$	$I_{1,2,3} = \frac{I_1+I_2+I_3}{3}$	$P_{1,2,3}=P_1+P_2$	$S_{1,2,3} = \frac{\sqrt{3}}{3} (U_1 I_1 + U_2 I_2 + U_3 I_3)$	$Q_{1,2,3} = \frac{\sqrt{3}}{3} \sqrt{(U_1 I_1)^2 - P_1^2 + s_1 \sqrt{(U_2 I_2)^2 - P_2^2}}$	$\lambda_{1,2,3} = s_u \left  \frac{P_{1,2,3}}{S_{1,2,3}} \right $	$\phi_{1,2,3} = s_u \cos^{-1}  \lambda_{1,2,3} $

Note 1: The above calculation algorithm is for a single phase, 2 wire input to ch 1, and 3 phase, 3 wire input to ch 1/2/3 (3 voltage, 3 current).

Note 2: The "s" before each power factor or phase operation indicates the lead or lag of current phase in relation to voltage. The "-" sign means current phase leads voltage and when there is no symbol, it lags. "su" is "-" when the sum of reactive power is negative and "+" (but unsigned) when it is positive.



## Basic specifications

Measurement line	: Single phase 2 wire, single phase 3 wire, 3 phase 3 wire (3V3A is possible), 3 phase 4 wire
Measurement item	: When using 9600, 9601, 9602 (optional) Voltage, current, voltage/current peak, effective/reactive/apparent power, power factor, phase, frequency, current/power integration, load rate, efficiency. When using the 9603 (optional) Voltage, torque, r/min, frequency, motor output. When using the 9605 (optional) Harmonic, waveform, voltage fluctuation / flicker measurement function.
Display indication range	: At the lowest range in the DC mode of Models 9600 & 9602: 0.2% to 130% At the lowest range in the AC+DC mode of Models 9600 & 9602: 0.5% to 130% At the 200mA range of Model 9601: 0.5% to 130% At 0.1% to 130% of all other ranges. All range is zero suppressed at less than lower % value. Valid input range for voltage, current, and power is 0.5% to 110%
Display	: 6.4 inch TFT color LCD (640 × 480 dot)
Display resolution	: 99999 count (except with integration), 9999999 count (with integration)
Rectification method	: Switchable between RMS (true root mean square value) and MEAN (average rectified RMS indication). When combined mode DC is selected, its not possible to switch between them.
Display update rate	: 8 times/sec.
Combined mode	: DC, AC + DC, AC (AC only when used in combination with 9601 or 9602 + AC clamp-on sensor)
Analog response time	: FAST (0.1 sec.), MID (0.8 sec.), SLOW (5.0 sec.) (Time required for stabilization to within ±1% when input is changed from 0% to 90%, or 100% to 10% of range.)
Low pass filter	: OFF / 500Hz / 5kHz / 300kHz (-3dB) For 9601, 5k / 300kHz not available.
Polarity detection regulation filter	: OFF / 200Hz (-3dB)
Analog output	: Voltage / current / active power DC ±5V f.s (1000V range is DC ±3.333 V f.s.)
Monitor output	: Voltage / current: 1Vrms f.s. (1000V range is 0.6667 Vrms f.s.)
[Voltage/ Current/ Active power measurement]	
Measurement range	: See Page 5 specifications for individual input units
[Integration measurement]	
Number of measurements	: 64 times/sec
Measurement range	: 0 to ±9999999 TAh / TWh (integration time up to 10,000 hours)
[Power factor/ Phase angle measurement]	
Measurement range	: -1.0000 (lead) to 0.0000 to 1.0000 (lag) -180°(lead) to 0.00° to 180.00°(lag)
[Frequency measurement]	
Number of channels	: Max. 3ch (selection of voltage or current for arbitrary channel)
Effective input range	: 0.5 Hz to 2 MHz
Measurement range	: Auto / 50Hz / 500Hz / 50 kHz / 2 MHz

### [Wave peak measurement]

Measurement items	: Select either voltage or current for each unit (Shows absolute value of max.)
Effective Input Range	: Effective value of sine wave is within effective input permissible in the range

### [Motor output (Pm) measured] 9603 (optional) external input unit required

Measurement method	: Digital calculation from measured voltage or pulse signal Effective when 9603 ch A is torque (any of N/ m, mN/m, kN/m, kgf/m, kgf/cm), and ch B is r/m
Display indication range	: 0.1% to 130% of 9603 voltage range (polarity not indicated)
Calculation algorithm	: Set to required format

### [Efficiency measurement]

Calculable factors	: Maximum of 3 formats
Calculated items	: P for each input unit, Pm when combined with 9603 (Items measured with 9605 not allowed)

### [D/A output]

Number of channels	: 8ch (12 bit D/A converter polarity + 11bit)
Output impedance	: 100Ω±5%
Output items	: Outputs 8 arbitrarily selected items
Output voltage	: DC±5V/f.s.
Output update rate	: 16 times/sec

### [Interface]

GP-IB	: Conforms to IEEE-488.1 1987, with reference to IEEE-488.2 1987
RS-232C	: Start-stop synchronous, with baud rate of 2400 or 9600 bits/sec

### [External Control]

Functions	: Integration start / stop control, Integration data reset, External A/D (For display update when power meter display is in hold mode), Manual print control
Control signal level	: From 0 / 5V logic signal or short//open contact signal

### [Other functions]

Scaling	: PT/CT ratio Set range 0.0001 to 99999
Averaging	: Time average (set interval time, timer time, and average of realtime control time) Moving average (number of samples: 8/16/32/64) Exponential average (attenuation factor: 8/16/32/64)
Multilingual display	: Japanese/English screen display switching
Set time (all types)	: Interval control time (10 sec to 100 hours) in 10 sec increments (When used in combination with printer, auto select increments) Timer control time (1 min to 10000 hours) in 1 minute increments Realtime control time, 1 minute increments

### [Harmonic / Flicker measurement] 9605 (optional) required

Measurement item	: See Page 4 specifications for 9605
------------------	--------------------------------------

## Measurement accuracy (Accuracy guaranteed for 6 months, Post-adjustment accuracy guaranteed for 6 months)

V, A, W	: Per accuracy table on page 5	Motor output	: ±1dgt for calculations of each measured value
Apparent / reactive power	: ±1 dgt. with respect to calculation from measured value (U, I, P) sum value is max. ±3dgt.	Efficiency	: Max. ±7 dgt with respect to values calculated from measurements of items substituted into algorithm
Integration	: ±1dgt with respect to values calculated from measurements (I, P)	Thermal coefficient	: Within ±0.03% f.s/ °C
Power factor	: Max. ±3dgt with respect to values calculated from measurements (U, I, P)	Effect of in-phase voltage	: Within ±0.05% f.s. (1000 Vrms, 50/60Hz, between shorted voltage input terminals and case)
Phase angle	: Max. ±3dgt with respect to values calculated from measurements (U, I, P)	Effect of power factor	: ±0.15% f.s (power factor = 0)
Frequency	: ±0.1% rdg. ±1 dgt. (0°C to 40°C(32°F to 104°F), for sine wave input between 10% to 130% of U/I range)	Actual time	: ±25ppm ±1dgt. (0 to 40°C (73°F to 41°F))
Wave peak	: ±1% (at 0.5Hz to 1kHz), ±2% (at 1kHz to 10kHz), ±10% (at 10kHz to 100kHz)	D/A output	: Display accuracy - ±0.2% f.s
		Analog output	: Display accuracy - ±0.2% f.s
		Monitor output	: Display accuracy - ±0.2% f.s (less than 100kHz) Display accuracy - ±3dB (100k to 1MHz)

## General Specifications

Location for use	: Indoors, altitude to 2000 m, Pollution level 2	Certifications	: Safety EN61010 EMC EN61326 EN61000-3-2 EN61000-3-3
Ambient use humidity	: Power meter, 0°C to 40°C (32°F to 104°F), rh below 80% (no condensation) When using printer, 5°C to 40°C (41°F to 104°F), rh below 80%	Power supply	: AC100V/120V/200V/230V (switched automatically), 50/60Hz
Ambient storage humidity	: -10°C to 50°C (14°F to 122°F), rh below 80% and no condensation	Maximum rated power	: 150VA max.
Maximum rated voltage to earth	: Using with the 9600 and 9601 Voltage input terminal, Current input terminal 600 V measurement category III (expected transient overvoltage: 6000 V) 1000 V measurement category II (expected transient overvoltage: 6000 V) Using with the 9602 Voltage input terminal 600 V measurement category III (expected transient overvoltage: 6000 V)	Dimensions, mass	: Approx 430 W × 150 H × 370 D mm, Approx 13 kg (Approx 16.93"(W) × 5.91" (H) × 14.57" (D), Approx 458.6 oz.) (in configuration including 9600 5 ch, 9603, 9604) (Not including projections such as terminals, feet, and handles)
Withstand voltage (50/60 Hz, 1 minute)	: AC5.55kV between U/I terminal and unit case, between U/I terminal and power supply plug (for 9600 and 9601), between U terminal and clamp input terminal, between U terminal and unit case, between U input terminal and power supply plug (for 9602)	Accessories	: Power cord 1, ground adapter (3P to 2P) 1, connector 1

# Current Sensors(Optional) Specifications

To use the Clamp-On sensor, be sure to order the factory option 9602 AC/DC Clamp Input Unit.

Model	AC/DC Current Sensors								AC Clamp-on Sensor	Conversion Adapter for AC only
	Feed-through current sensors				Clamp-on sensors				CT	
Model	CT6865 *	9709 *	CT6863 *	CT6862 *	9279-01	CT6843	CT6841	9272-10 *	9290-10	
Physical appearance										CT ratio 10:1 For 9272-10 only
Primary current rating	1000A	500A	200A	50A	500A	200A	20A	200A/20A	1500A	
Measurable conductor diameter	φ36mm (1.42in)	φ36mm (1.42in)	φ24mm (0.94in)	φ24mm (0.94in)	φ40mm (1.57in)	φ20mm (0.79in)	φ20mm (0.79in)	φ46mm (1.81in)	φ55mm (2.17in)	
Accuracy 45 to 66Hz 23°C±3°C (73°F±5.4°F)	±0.05%rdg. ±0.01%f.s. (vibration amplitude) ±0.2° max.(phase, DC not specified)	Warming up for at least 10 minutes: ±0.05%rdg. ±0.01%f.s. (vibration amplitude) ±0.2° max.(phase, DC not specified)	±0.05%rdg. ±0.01%f.s. (vibration amplitude) ±0.2° max. (phase, DC not specified)	±0.05%rdg. ±0.01%f.s. (vibration amplitude) ±0.2° max. (phase, DC not specified)	After degaussing and warming up for at least 30 minutes: ±0.5%rdg. ±0.05%f.s. (vibration amplitude) ±0.2° max.(phase, DC not specified)	±0.3%rdg.±0.01%f.s. (vibration amplitude) ±0.1° max. (phase, DC not specified)	±0.3%rdg. ±0.01%f.s. (vibration amplitude) ±0.2° max. (phase)	±0.3%rdg. ±0.01%f.s. (vibration amplitude) ±0.2° max. (phase)	±1.5%rdg. (vibration amplitude) ±0.2° max. (phase)	
Frequency characteristics (vibration amplitude, phase) (deviation from the basic accuracy)	DC to 16Hz : ±0.1% max. To 5kHz : ±5.0% max. To 20kHz : ±30% max	DC to 45Hz : ±0.2% max. To 10kHz : ±2.0% max. To 100kHz : ±30% max	DC to 16Hz: : ±0.1% max. To 100kHz : ±2.0% max. To 500kHz : ±30% max	DC to 16Hz : ±0.1% max. To 100kHz : ±5.0% max. To 1MHz : ±30% max	DC to 1kHz : ±1.0% max. To 10kHz : ±2.5% max. To 20kHz : ±5.0% max	DC to 500Hz : ±0.3% max. To 10kHz : ±1.5% max. To 500kHz : ±30% max	DC to 500Hz : ±0.3% max. To 10kHz : ±1.5% max. To 1MHz : ±30% max	1Hz to 5kHz : ±2.0% max. To 10kHz : ±2.5% max. To 100kHz : ±30% max	20Hz to 5kHz : ±2.0% max	
others	Set CT ratio : 2									80mm(3.15 in) ×20mm(0.79in) busbar

\*For further details, please refer to the individual product catalog for the instrument.

## Ordering information

### POWER HITESTER

Order Code: 3193-10 (main unit only)

Note: Main unit 3193-10 cannot operate alone - please purchase an input unit Model 9600 to 9605 for factory installation prior to shipment. All subsequent input unit replacements or expansions must be conducted at HIOKI for an additional service charge.

( ) : 9600, 9601, 9602 can be selected.

	1ch	2ch	3ch	4ch	5ch	6ch
Pattern A	1 φ 2W ( )	1 φ 2W ( )	1 φ 2W ( )	1 φ 2W ( )	1 φ 2W ( )	1 φ 2W ( )
Pattern B	1 φ 3W / 3 φ 3W ( ×2)	1 φ 2W ( )	1 φ 2W ( )	1 φ 2W ( )	1 φ 2W ( )	1 φ 2W ( )
Pattern C	1 φ 3W / 3 φ 3W ( ×2)	1 φ 3W / 3 φ 3W ( ×2)	1 φ 2W ( )	1 φ 2W ( )	1 φ 2W ( )	1 φ 2W ( )
Pattern D	1 φ 3W / 3 φ 3W ( ×2)	1 φ 3W / 3 φ 3W ( ×2)	1 φ 3W / 3 φ 3W ( ×2)	1 φ 2W ( )	1 φ 2W ( )	1 φ 2W ( )
Pattern E	3V3A (3 φ 3W) / 3 φ 4W ( ×3)	1 φ 2W ( )	1 φ 2W ( )	1 φ 2W ( )	1 φ 2W ( )	1 φ 2W ( )
Pattern F	3V3A (3 φ 3W) / 3 φ 4W ( ×3)	1 φ 3W / 3 φ 3W ( ×2)	1 φ 2W ( )	1 φ 2W ( )	1 φ 2W ( )	1 φ 2W ( )
Pattern G	3V3A (3 φ 3W) / 3 φ 4W ( ×3)	3V3A (3 φ 3W) / 3 φ 4W ( ×3)	3V3A (3 φ 3W) / 3 φ 4W ( ×3)	3V3A (3 φ 3W) / 3 φ 4W ( ×3)	3V3A (3 φ 3W) / 3 φ 4W ( ×3)	3V3A (3 φ 3W) / 3 φ 4W ( ×3)

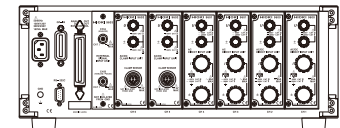

### Notes on input unit selection

- Use the same input unit for a particular measurement line.
- Install units in succession starting from channel 1.
- For the 9603 only one unit can be installed.
- When the 9602 is selected, use an optional clamp-on sensor.

### Options that can be installed at the factory (specify at time of order)

AC/DC DIRECT INPUT UNIT 9600  
AC DIRECT INPUT UNIT 9601  
AC/DC CLAMP INPUT UNIT 9602  
EXTERNAL SIGNAL INPUT UNIT 9603  
PRINTER UNIT 9604 \* Not CE marked  
HARMONIC / FLICKER MEASUREMENTS UNIT 9605 \* Not CE marked

\*Voltage cables are not supplied. Also, please contact your HIOKI distributor for clip type leads or other special needs.

### Options

AC/DC CURRENT SENSOR CT6865 (1000A AC/DC)  
AC/DC CURRENT SENSOR 9709 (500A AC/DC)  
AC/DC CURRENT SENSOR CT6863 (200A AC/DC)  
AC/DC CURRENT SENSOR CT6862 (50A AC/DC)  
UNIVERSAL CLAMP ON CT 9279-01 (500A AC/DC)  
AC/DC CURRENT PROBE CT6843 (200A AC/DC)  
AC/DC CURRENT PROBE CT6841 (20A AC/DC)  
CLAMP ON SENSOR 9272-10 (20/200A AC)  
CLAMP ON ADAPTER 9290-10 (1500A AC, ratio10:1)  
VOLTAGE CORD L9438-50 (1 each red and black, approx 3m)  
RECORDING PAPER 9232 (10 m, 10 roll, For 9604)

Note: Company names and Product names appearing in this catalog are trademarks or registered trademarks of various companies.

# HIOKI

HIOKI E. E. CORPORATION

#### HEADQUARTERS

81 Koizumi, Ueda, Nagano, 386-1192, Japan  
TEL +81-268-28-0562 FAX +81-268-28-0568  
http://www.hioki.com / E-mail: os-com@hioki.co.jp

#### HIOKI USA CORPORATION

TEL +1-609-409-9109 FAX +1-609-409-9108  
http://www.hioki.com / E-mail: hioki@hioki.com

HIOKI (Shanghai) SALES & TRADING CO., LTD.  
TEL +86-21-63910090 FAX +86-21-63910360  
http://www.hioki.cn / E-mail: info@hioki.com.cn

DISTRIBUTED BY

HIOKI INDIA PRIVATE LIMITED  
TEL +91-124-6590210  
E-mail: hioki@hioki.in

HIOKI SINGAPORE PTE. LTD.  
TEL +65-6634-7677 FAX +65-6634-7477  
E-mail: info-sg@hioki.com.sg

HIOKI KOREA CO., LTD.  
TEL +82-2-2183-8847 FAX +82-2-2183-3360  
E-mail: info-kr@hioki.co.jp